



# Standard Test Method for Measuring the Soil-Geotextile System Clogging Potential by the Gradient Ratio<sup>1</sup>

This standard is issued under the fixed designation D 5101; the number immediately following the designation indicates the year of original adoption or, in the case of revision, the year of last revision. A number in parentheses indicates the year of last reapproval. A superscript epsilon ( $\epsilon$ ) indicates an editorial change since the last revision or reapproval.

## 1. Scope

1.1 This test method covers a performance test applicable for determining the soil-geotextile system permeability and clogging behavior for cohesionless soils under unidirectional flow conditions.

1.2 The values stated in SI units are to be regarded as standard. The values in parentheses are for information only.

1.3 *This standard does not purport to address all of the safety concerns, if any, associated with its use. It is the responsibility of the user of this standard to establish appropriate safety and health practices and determine the applicability of regulatory limitations prior to use.*

## 2. Referenced Documents

### 2.1 ASTM Standards:

D 123 Terminology Relating to Textiles<sup>2</sup>

D 653 Terminology Relating to Soil, Rock, and Contained Fluids<sup>3</sup>

D 737 Test Method for Air Permeability of Textile Fabrics<sup>3</sup>

D 4354 Practice for Sampling of Geosynthetics for Testing<sup>4</sup>

D 4439 Terminology for Geosynthetics<sup>4</sup>

## 3. Terminology

### 3.1 Definitions:

3.1.1 *clogging potential,  $n$* —in geotextiles, the tendency for a given fabric to lose permeability due to soil particles that have either lodged in the fabric openings or have built up a restrictive layer on the surface of the fabric.

3.1.2 *geotextile,  $n$* —a permeable geosynthetic comprised solely of textiles.

3.1.3 *gradient ratio,  $n$* —in geotextiles, the ratio of the hydraulic gradient through a soil-geotextile system to the hydraulic gradient through the soil alone.

3.1.4 *hydraulic gradient,  $i, s (D)$* —the loss of hydraulic head per unit distance of flow,  $dH/dL$ .

3.1.5 For definitions of other textile terms, refer to Terminology D 123. For definitions of other terms related to geotextiles, refer to Terminology D 4439 and Terminology D 653.

3.2 *Acronyms: Symbols and Acronyms:*

3.2.1 *CO<sub>2</sub>*—the chemical formula for carbon dioxide gas.

3.2.2 *CHD*—the acronym for constant head device.

## 4. Summary of Test Method

4.1 This test method requires setting up a cylindrical, clear plastic permeameter (see Fig. 1 and Fig. 2) with a geotextile and soil, and passing water through this system by applying various differential heads. Measurements of differential heads and flow rates are taken at different time intervals to determine hydraulic gradients. The following test procedure describes equipment needed, the testing procedures, and calculations.

## 5. Significance and Use

5.1 This test method is recommended for evaluating the performance of various soil-geotextile systems under controlled test conditions. Gradient ratio values obtained may be plotted and used as an indication of the soil-geotextile system clogging potential and permeability. This test method is not appropriate for initial comparison or acceptance testing of various geotextiles. The test method is intended to evaluate geotextile performance with specific on-site soils. It is improper to utilize the test results for job specifications or manufacturers' certifications.

5.2 It is important to note the changes in gradient ratio values with time versus the different system hydraulic gradients, and the changes in the rate of flow through the system (see Section 11 and Annex A1.).

## 6. Apparatus and Supplies

6.1 *Soil-Geotextile Permeameter*—(three-piece unit) equipped with support stand, soil-geotextile support screen, piping barriers (caulk), clamping brackets, and plastic tubing (see Fig. 2). Both 100-mm (4-in.) and 150-mm (6-in.) diameter permeameters are described.

6.2 *Two Constant Water Head Devices*, one mounted on a jack stand (adjustable) and one stationary (Fig. 3).

6.3 *Soil Leveling Device* (Fig. 4).

6.4 *Manometer Board*, of parallel glass tubes and measuring rulers.

<sup>1</sup> This test method is under the jurisdiction of ASTM Committee D35 on Geosynthetics and is the direct responsibility of Subcommittee D35.03 on Permeability and Filtration.

Current edition approved July 10, 2001. Published October 2001. Originally published as D 5101 – 90. Last previous edition D 5101 – 00.

<sup>2</sup> *Annual Book of ASTM Standards*, Vol 07.01.

<sup>3</sup> *Annual Book of ASTM Standards*, Vol 04.08.

<sup>4</sup> *Annual Book of ASTM Standards*, Vol 07.01.

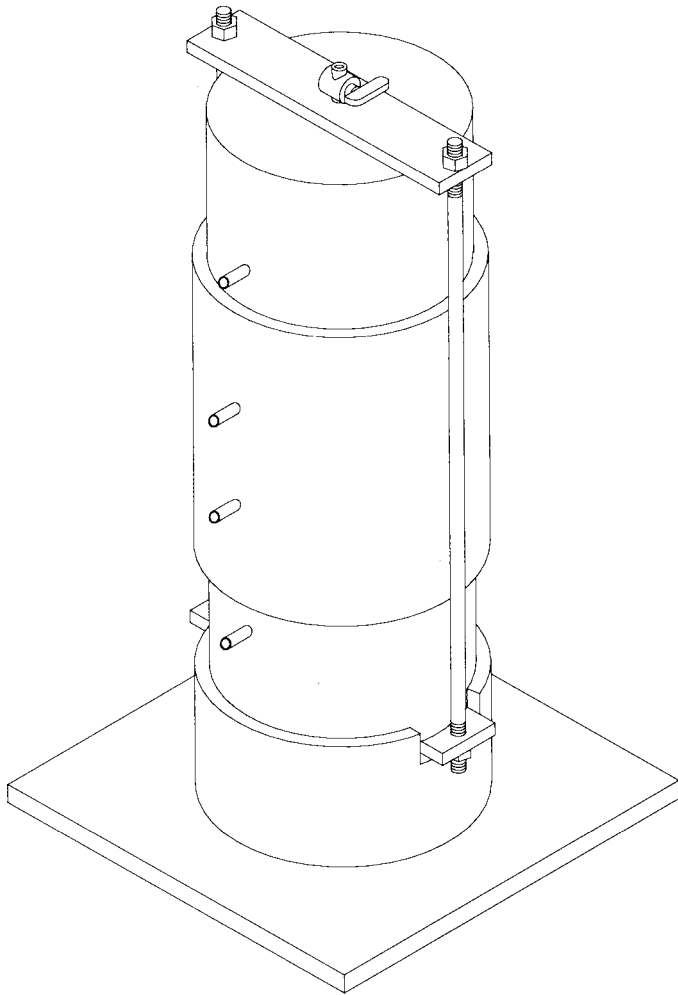

**FIG. 1 Geotextile Permeameter**

- 6.5 *Two Soil Support Screens*, of approximately 5 mm (No. 4) mesh.
- 6.6 *Soil Support Cloth*, of 150  $\mu\text{m}$  (No. 100) mesh, or equivalent geotextile.
- 6.7 *Thermometer* (0 to 50  $\pm$  1°C).
- 6.8 *Graduated Cylinder*, 100  $\pm$  1 cm<sup>3</sup> capacity.
- 6.9 *Stopwatch*.
- 6.10 *Balance*, or scale of at least 2-kg capacity and accurate to  $\pm$ 1 g.
- 6.11 *Carbon Dioxide*, (CO<sub>2</sub>), gas supply and regulator.
- 6.12 *Geotextile*.
- 6.13 *Water Recirculation System*.
- 6.14 *Water Deairing System*, with a capacity of approximately 1700 L/day (500 gal/day).
- 6.15 *Algae Inhibitor*, or micro screen.
- 6.16 *150- $\mu\text{m}$  Mesh Screen*, (No. 100), or equivalent geotextile for manometer ports.
- 6.17 *Soil Sample Splitter* (optional).
- 6.18 *Pan*, for drying soil.
- 6.19 *Mortar and Pestle*, for pulverizing soil.
- 6.20 *Wooden rod*, 20-mm ( $\frac{3}{4}$ - in.) diameter by 150 mm (6 in.) long.

## 7. Sampling and Test Specimens

- 7.1 *Lot Sample and Laboratory Sample*—Take a lot sample

and laboratory samples as directed in Practice D 4354. For laboratory samples, take a full width swatch of geotextile from each roll of material in the lot sample at least 1 m (3 ft) long cut from the end of the roll after discarding the first metre of material from the outside of the roll.

7.2 *Test Specimen*—Cut one circular specimen from each swatch in the laboratory sample with the specimen having a diameter of 110 mm (4.33 in.) or 165 mm (6.50 in.). Take the specimen from the center of the swatch.

## 8. Conditioning

### 8.1 Test Water Preparation:

8.1.1 Test water should be maintained at room temperature about 16 to 27°C (60 to 80°F), and deaired to a dissolved oxygen content of 6 parts per million (ppm) or less before introducing it to permeameter system. This will reduce or eliminate the problems associated with air bubbles forming within the test apparatus.

8.1.2 An algae inhibitor or micro screen should be used to eliminate any algae buildup in the system.

### 8.2 Specimen Conditions:

8.2.1 Condition the specimen by soaking it in a container of deaired water for a period of 2 h. Dry the surface of the specimen by blotting prior to inserting in the permeameter.

## 9. Procedure

### 9.1 Preparation of Apparatus:

9.1.1 Thoroughly clean and dry permeameter sections.

9.1.2 Close all valves and cover the inside openings of all manometer ports with fine wire mesh or lightweight nonwoven fabric (the equivalent of No. 100 mesh).

9.1.3 Lubricate all O-ring gaskets.

### 9.2 Permeameter Preassembly:

9.2.1 Stand center section of the permeameter on end and place a soil support cloth 110 mm (4.33 in.) or 165 mm (6.5 in.) in diameter on recessed permeameter flanges.

9.2.2 Insert the support screen 110 mm (4.33 in.) or 165 mm (6.5 in.) in diameter on top of the support cloth with the mesh side against the cloth.

9.2.3 Align and insert top section of the permeameter into center section and press until there is a tight fit to secure the support cloth and screen in place. Ensure that all gasket edges secure against the support cloth, support bracket, and between the center and top permeameter sections.

9.2.4 Invert and place permeameter into holding stand.

### 9.3 Process Soil:

The test is to be performed on minus  $\frac{3}{8}$  in. material. The material passing the  $\frac{3}{8}$  in. and retained on the No. 10 sieve is subject to a second round of grinding to ensure that the sample has been broken down into individual grains.

9.3.1 Thoroughly air dry the soil sample as received from the field. This shall be done for a minimum of three days. Grind the sample in a mortar with a rubber-tipped pestle (or in some other way that does not cause breakdown of individual grains), to reduce the particle size to a maximum of 10 mm ( $\frac{3}{8}$  in.). Select a representative sample of the amount required (approximately 1350 (or 3000 g for the 150-mm (6-in.) diameter) to perform the test by the method of quartering or by the use of a soil splitter.

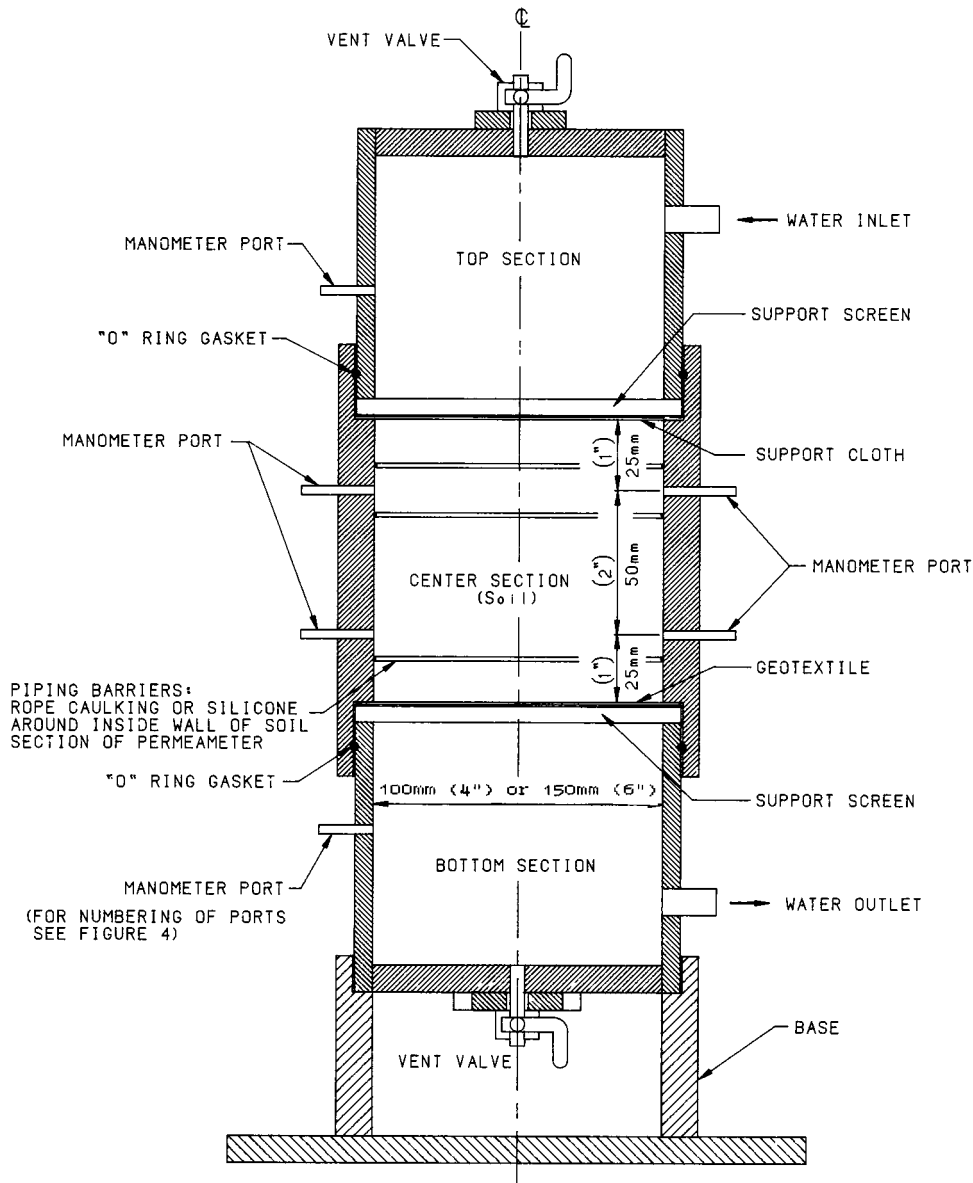

**FIG. 2 Section—Geotextile Permeameter**

9.3.2 Select that portion of the air-dried sample selected for purpose of tests and record the mass as the mass of the total test sample uncorrected for hygroscopic moisture. Separate the test sample by sieving with a 2-mm (No. 10) sieve. Grind that fraction retained on the 2-mm (No. 10) sieve in a mortar with a rubber-covered pestle until the aggregations of soil particles are broken up into the separate grains.

9.3.3 Mix the fractions passing the 2-mm (No. 10) sieve along with the portion that was retained on the 2-mm (No. 10) sieve to form the test soil. All particles larger than 10 mm ( $\frac{3}{8}$  in.) should be eliminated.

9.4 *Soil Placement*—The following procedures offer two options to the user. The first is a “standard” placement while the second is a “field condition” placement. The placement procedure is a critical aspect of the test and may significantly influence the test results.

9.4.1 *Standard Placement Method:*

9.4.1.1 Weigh out approximately 1350 g of air-dried pro-

cessed soil (or 3000 g for the 150-mm (6-in.) diameter).

9.4.1.2 Place air-dried processed soil above the support cloth to a depth of 103 mm (4.12 in.). The final depth of soil after settlement will be approximately 100 mm (4 in.). The soil should be placed in 25-mm (1-in.) to 40-mm (1½-in.) layers, making sure that no voids exist along the permeameter walls at manometer ports, or the caulk piping barriers. The soil shall be placed carefully into the permeameter with a scoop or appropriate tool with a maximum drop of the soil no greater than 25 mm (1 in.). Consolidation of each layer shall consist of tapping the side of the permeameter six times with a wooden rod, 20 mm ( $\frac{3}{4}$  in.) by 150 mm (6 in.) in diameter.

9.4.1.3 When the level of the soil in the permeameter reaches a depth of 100 mm (4 in.), insert the soil leveling device (Fig. 4), with the notch down, on the top edges of the permeameter. Continue placing soil and rotating the leveling device until the total soil height of 103 mm (4.12 in.) is reached.

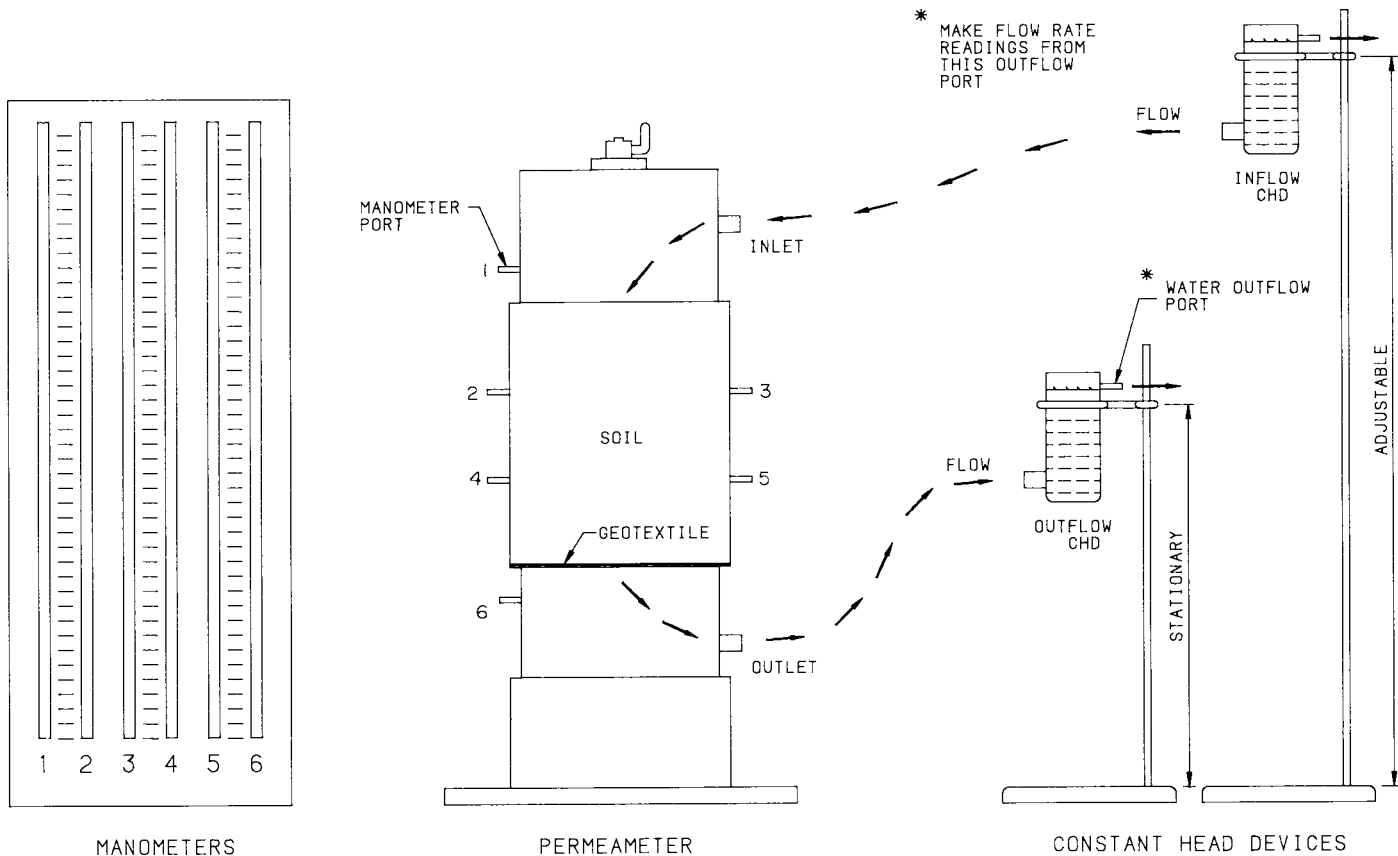

FIG. 3 Geotextile Permeameter "Set Up" Diagram

9.4.1.4 Remove the soil leveler and any excess soil. Determine the mass of the soil in the permeameter for unit weight calculations.

NOTE 1—The standard soil placement procedure results in a relatively loose soil condition and is conservative for many applications. If a density approximating actual field soil conditions is desirable, the field condition procedure should be used. It should be recognized, however, that predicting field soil conditions may be very difficult due to construction installation procedures that generally disturb and loosen soils adjacent to the geotextile.

9.4.2 Field Condition Soil Placement Method:

9.4.2.1 Based on the desired field dry density, weigh out the processed dry soil required to achieve the target dry density in the permeameter used with a 100 mm (4 in) soil height.

9.4.2.2 Place the dry soil in four one-inch lifts using the end of the wooden dowel to compact the soil, making sure that no voids exist along the permeameter walls at the manometer ports or the caulk piping barriers.

9.4.2.3 Fill the permeameter to achieve the soil height of 100 mm (4 in). Determine the mass of soil used for unit weight calculations.

NOTE 2—Should the target density be unachievable without increasing the compaction effort, record the density actually achieved. While the looser condition may be somewhat more conservative, the dry placement and CO<sub>2</sub> purge are considered critical to reliable results.

9.5 Permeameter Assembly and Setup:

9.5.1 Clean the inner flange of the center section of the permeameter and insert the geotextile to be tested.

9.5.2 Insert the support screen on top of the geotextile with the mesh side against the geotextile.

9.5.3 Align and insert the bottom section of the permeameter into the center section and press tightly to secure the geotextile and support screen. The soil will compress from 103 mm (4.12 in.) to approximately 100 mm (4 in.) when the bottom section is secured. Check gaskets to ensure contact is made between permeameter sections, support screen, and geotextile.

9.5.4 Secure the permeameter sections together within clamp brackets and tighten bolts on bracket rods evenly.

9.5.5 Invert permeameter into holding stand so that the geotextile will be below the soil level.

9.5.6 Connect the inflow and outflow constant head devices (CHD) to their corresponding permeameter ports (see Fig. 3) with plastic tubing. The outflow CHD is attached to the bottom permeameter port and the inflow CHD is attached to the top permeameter port.

9.5.7 Connect all manometer tubes (1 through 5) to their corresponding permeameter manometer ports, and all overflow tubes to their corresponding outlet ports.

9.6 Saturating the Soil/Geotextile System:

9.6.1 Open the top vent valve, and close off the permeameter water outlet hose.

9.6.2 Backfill permeameter with water through the outflow CHD until the water level is approximately 10 mm (3/8 in.) below the open manometer port 6. Stop waterflow into the

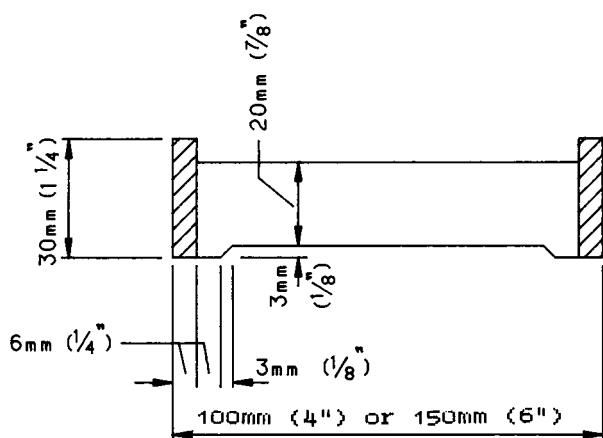

**SECTION A-A**

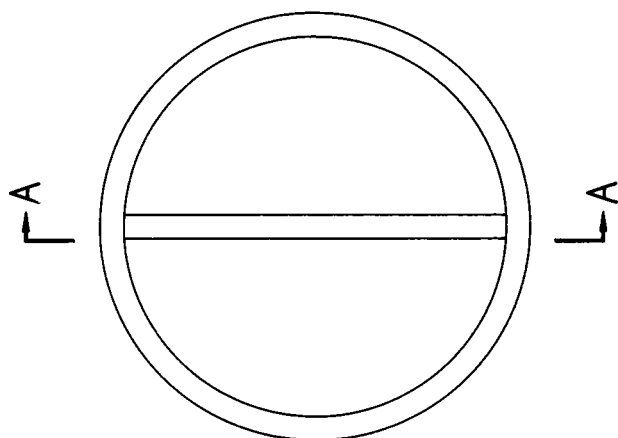

**FIG. 4 Plan—Soil Leveling Tool**

permeameter by clamping off the hose between outflow CHD and permeameter.

9.6.3 Expel oxygen and other gases in the permeameter and soil system by (1) attaching a carbon dioxide ( $\text{CO}_2$ ) line to manometer port 6, and (2) regulating the gas flow at 2 L/min and purging the system for 5 min.

9.6.4 After 5 min of gas saturation, seal off (plug) the open end of each manometer tube (1 through 5) and continue to purge the system with  $\text{CO}_2$  for an additional 5 min with only the top vent valve open.

9.6.5 Remove the  $\text{CO}_2$  gas line and replace the No. 6 manometer hose. Remove the seals (plugs or clamps) from all manometer tubes (1 through 5).

9.6.6 Loosen the hose clamp between the outflow CHD and permeameter, and fill the soil section of the permeameter with

water. Filling is accomplished by adding water to and raising the level on outflow CHD slowly. Start with outflow CHD at 25 mm (1 in.) above the geotextile level and raise 25 mm (1 in.) every 30 min until water level is 50 mm (2 in.) above the top support screen bracket. This slow saturating process is necessary to prevent air pockets or internal soil movement during loading.

9.6.7 Clamp the hose between outflow CHD and permeameter to prevent flow. Continue to raise the water level in the permeameter by filling from the top inlet through the inflow CHD. The outflow CHD should be clamped so that no flow occurs through the system. The water level should be raised until water flows from the top vent valve. Position outflow CHD so that its overflow outlet is approximately 25 mm (1 in.) above the permeameter soil level. The system should be in no-flow condition and the manometers should all read the same.

9.6.8 Close off the top vent valve and allow the system to stand overnight in a static condition. This should ensure complete saturation of the system with water. The system should be in a no-flow condition overnight.

9.6.9 Check for and remove air bubbles found in the tubes or manometers by light vibration or tapping. It may be necessary to disconnect tubing from the manometer board and slowly lower the tubing, allowing water and entrapped air to run out.

9.6.10 Place a thermometer into the inflow CHD to monitor the temperature of water flowing into the permeameter.

#### 9.7 Running the Test:

9.7.1 Check to make sure that all scales on the manometer board are set to a common reference elevation.

9.7.2 Adjust the inflow CHD to a level so that a hydraulic gradient ( $i$ ) of 1 is obtained (see 10.1).

9.7.3 Unclamp hoses between the permeameter and CHDs to allow flow, and record the initial starting time.

9.7.4 Record the following data (using Fig. 5) at 0, 1/2, 1, 2, 4, 6, and 24 h from the initial starting time and every 24 h thereafter until the system stabilizes (see Note 3).

9.7.4.1 The time in hours (accumulated).

NOTE 3—Stabilization is defined as the point where the flow rate and gradient ratio for three consecutive readings are within 10 % of their apparent value. In some cases, the readings may continue to change in a gradual but steady manner with no tendency toward stabilization. In this situation, the test may be terminated with an appropriate notation made on the test record.

9.7.4.2 The flow rate from the system (outflow CHD); time in seconds ( $t$ ) for a measured quantity of flow ( $Q$ ) in cubic centimetres. Measure for a minimum duration of 30 s and a minimum quantity of flow of  $10 \text{ cm}^3$ .

9.7.4.3 The temperature ( $T$ ) of the water in the system in degrees celsius.

9.7.4.4 The water level readings from the individual manometers.

9.7.4.5 The date and time of day.

9.7.5 After the final reading when the system stabilization has occurred, raise the inflow CHD to obtain a system hydraulic gradient ( $i$ ) = .5. Record the time. After 1/2 h at this level, record all data.



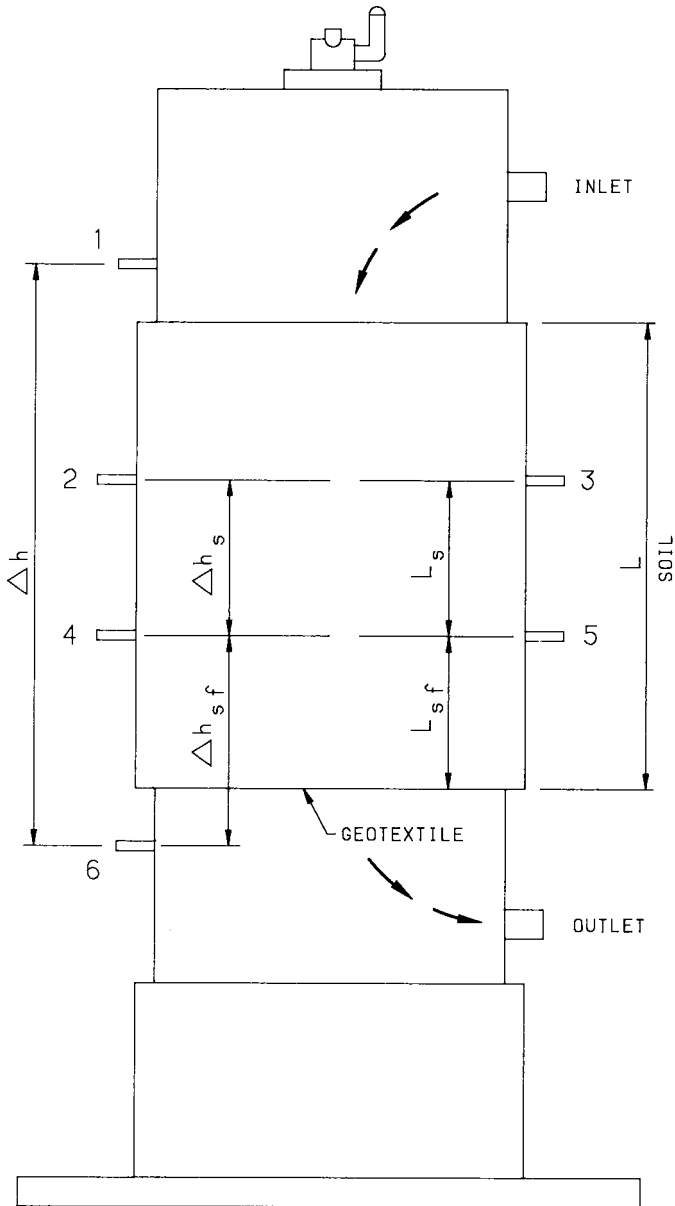

FIG. 6 Values for Gradient Ratio and Hydraulic Gradient Calculations

- 11.2.1 Unit weight of dry soil in the permeameter,
- 11.2.2 Permeameter diameter,
- 11.2.3 All instrument readings, such as flow volume, flow time, temperature, and manometer readings,
- 11.2.4 System permeability corrected to 20°C,
- 11.2.5 A plot of the gradient ratio to the nearest 0.1 unit against time for each hydraulic gradient tested,
- 11.2.6 A plot of the permeability and flow rate to three significant digits against time, and
- 11.2.7 A plot of the gradient ratio versus the system hydraulic gradient.

**12. Precision and Bias**

12.1 *Precision*—Precision of this test method is being established.

12.2 *Bias*—The procedure in Test Method D 5101 for measuring the soil-geotextile system permeability and clogging potential has no bias because the value of the gradient ratio and permeability can be defined only in terms of a test method.

**13. Keywords**

13.1 clogging potential; gradient ratio; soil-geotextile system

Test Method D 5101. Describe the material or product tested and the method of sampling used.

11.2 Report the following information:

**ANNEX****(Mandatory Information)****A1. INTERPRETATION OF RESULTS**

A1.1 The gradient ratio test is best suited for evaluating the movement of finer solid particles in coarse grained or gap graded materials where internal stability from differential hydraulic gradients may be a problem. The important aspect of the gradient ratio values obtained during the testing is not so much the number itself, but whether or not positive flow and permeability is maintained and there is the establishment of some recognizable equilibrium or stabilization of the system.

A1.2 A gradient ratio of one or slightly less is preferred. A value less than one is an indication that some soil particles have moved through the system and a more open filter bridge has developed in the soil adjacent to the geotextile. A continued

decrease in gradient ratio indicates piping and may require quantitative evaluation to determine filter effectiveness. Although gradient ratio values of higher than one mean that some system clogging and flow restriction has occurred, if system equilibrium is present, the resulting flow may well satisfy design requirements.

A1.3 The allowable gradient ratio values and related flow rates for various soil-geotextile systems will be dependent on the specific site application. It is the responsibility of the design professional to establish these allowable values on a case-by-case basis.

*ASTM International takes no position respecting the validity of any patent rights asserted in connection with any item mentioned in this standard. Users of this standard are expressly advised that determination of the validity of any such patent rights, and the risk of infringement of such rights, are entirely their own responsibility.*

*This standard is subject to revision at any time by the responsible technical committee and must be reviewed every five years and if not revised, either reapproved or withdrawn. Your comments are invited either for revision of this standard or for additional standards and should be addressed to ASTM International Headquarters. Your comments will receive careful consideration at a meeting of the responsible technical committee, which you may attend. If you feel that your comments have not received a fair hearing you should make your views known to the ASTM Committee on Standards, at the address shown below.*

*This standard is copyrighted by ASTM International, 100 Barr Harbor Drive, PO Box C700, West Conshohocken, PA 19428-2959, United States. Individual reprints (single or multiple copies) of this standard may be obtained by contacting ASTM at the above address or at 610-832-9585 (phone), 610-832-9555 (fax), or service@astm.org (e-mail); or through the ASTM website (www.astm.org).*