



# Standard Test Method for Vertical Compression of Geocomposite Pavement Panel Drains<sup>1</sup>

This standard is issued under the fixed designation D 6244; the number immediately following the designation indicates the year of original adoption or, in the case of revision, the year of last revision. A number in parentheses indicates the year of last reapproval. A superscript epsilon ( $\epsilon$ ) indicates an editorial change since the last revision or reapproval.

## 1. Scope

1.1 This test method evaluates vertical strain and core area change of geocomposite pavement panel drains under vertical loading.

1.2 The values as stated in SI units are to be regarded as the standard. The values given in parentheses are for information only.

1.3 *This standard does not purport to address all of the safety concerns, if any, associated with its use. It is the responsibility of the user of this standard to establish appropriate safety and health practices and determine the applicability of regulatory limitations prior to use.*

## 2. Referenced Documents

- 2.1 *ASTM Standards:*  
D 1566 Terminology Relating to Rubber<sup>2</sup>  
D 4354 Practice for Sampling of Geosynthetics for Testing<sup>3</sup>  
D 4439 Terminology for Geotextiles<sup>3</sup>

## 3. Terminology

3.1 *Definitions of Terms Specific to This Standard:*

3.1.1 *compressive deformation, n*—the decrease in gage length produced in the test specimen by a compressive load, expressed in units of length (new).

3.1.2 *compressive strain, n*—the ratio of compressive deformation to the gage length of the test specimen, expressed as a dimensionless ratio (new).

3.1.3 *gage length, n*—the known distance between two bench marks (see Terminology D 1566).

3.1.3.1 *Discussion*—In compression testing of geosynthetics gage length is the measured thickness of the test specimen under specified compressional force, expressed in units of length.

3.1.4 *geosynthetic, n*—a planar product manufactured from polymeric material used with foundation, soil, rock, earth, or any other geotechnical engineering related materials as an integral part of a manmade project, structure, or system (see Terminology D 4439).

<sup>1</sup> This test method is under the jurisdiction of ASTM Committee D-35 on Geosynthetics and is the direct responsibility of Subcommittee D35.01 on Mechanical Properties.

Current edition approved March 10, 1998. Published December 1998.

<sup>2</sup> *Annual Book of ASTM Standards*, Vol 09.01.

<sup>3</sup> *Annual Book of ASTM Standards*, Vol 04.09.

3.1.5 *index test, n*—a test procedure, which may contain a known bias but which may be used to order a set of specimens with respect to the property of interest (see Terminology D 4439).

## 4. Summary of Test Method

4.1 Geocomposite pavement panel drains are placed into a 304.8-mm (12-in.) long, 106.7-mm (4.20-in.) wide, and 610-mm (24-in.) tall glass and aluminum compression chamber. The panels are placed against the wall of the chamber. The remainder of the chamber is then backfilled with a specified sand. A vertical load is applied at a constant rate. The vertical strains of the panels and change in core area and height is recorded at 1112.5-N (250-lb) increments. The test is discontinued at 4450 N (1 000 lb) or 156.5 kPa (22.7 psi). The change in vertical strain, core height, and core area is determined.

## 5. Significance and Use

5.1 The vertical compression test for geocomposite pavement panel drains is intended to simulate vertical, horizontal, and eccentric loading resulting from an applied vertical load. The results of the analyses, including vertical strain of the panels and core area change, may be used as an index test. The vertical compression test may be used to evaluate core area change for a given load.

5.2 The vertical compression test may be used to evaluate percent vertical strain for a given load.

5.3 This test method may be modified to evaluate core area change and vertical strain under various backfill conditions.

## 6. Apparatus

6.1 *Compression Machine*—A compression machine that is capable of producing at least 4450 N (1 000 lb) of load. The machine must be capable of loading at a rate of 445 N (100 lbs)/min, and maintaining a constant load for an indefinite period.

6.2 *Compression Box*—The box must be capable of holding the specimen and the backfill material, and it must be capable of supporting a minimum vertical load of 4450 N (1 000 lb). The design of the box and the loading plate shall conform to the attached Fig. 1. The box shall be rigid enough to resist deformation.

6.3 *Clear Plastic Spacers (shown and described in Fig. 2)*—These spacers are used to protect the tempered glass ends

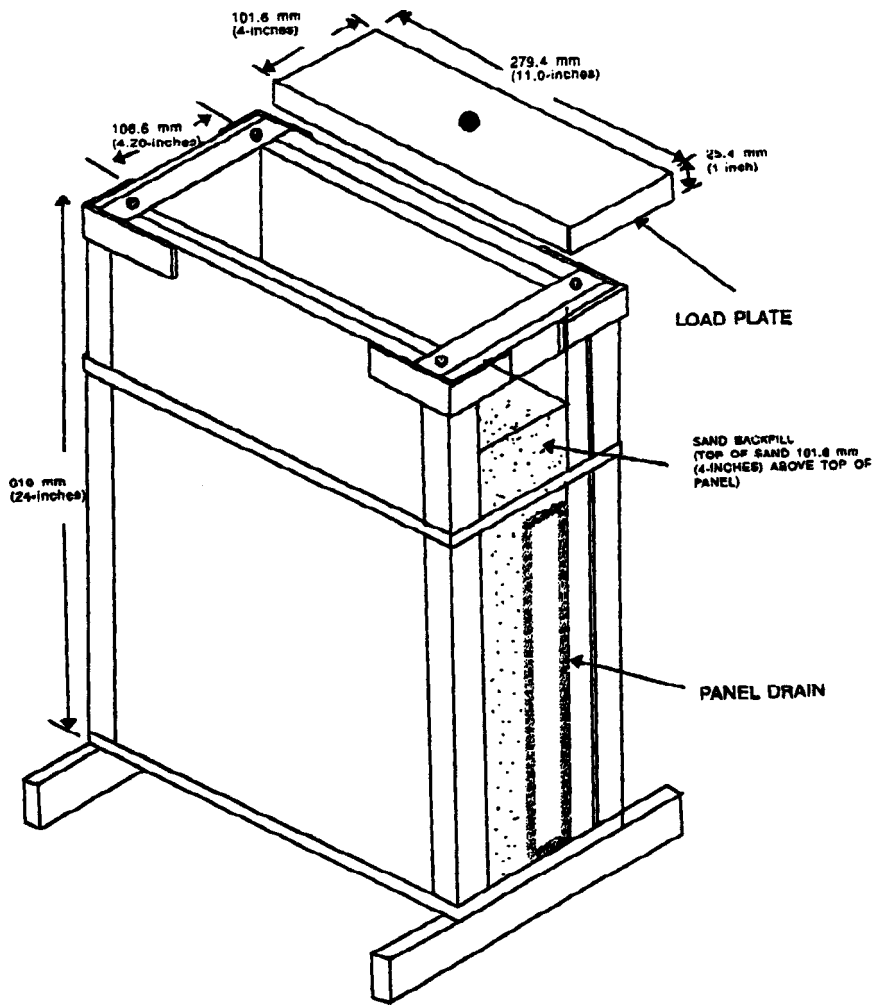

FIG. 1 Edge Drain Compression Chamber

of the compression box from scratches.

6.4 *Sand*—Sufficient sand to fill the compression box. Natural sand is recommended. The sand shall have a gradation conforming to Table 1. The sand shall be oven dried and cooled to room temperature.

6.5 *Tracing Paper*—The paper must be suitable for tracing and have a minimum size of 220 mm by 508 mm (8.5 in. by 20 in.).

6.6 *Light Source*—Any high intensity point light source is acceptable (for example a large mag light).

6.7 *Planimeter*—The planimeter is used to determine area to calculate loss of core area at the various load increments (a minimum of a digital planimeter should be used to calculate core area). If computer digitizing equipment or scanning equipment is available, this may be used in lieu of the planimeter.

6.8 *Scale (Length Measuring Device)*—A minimum range of 450 mm (18 in.), and an accuracy of 1 mm ( $1/16$  in.).

## 7. Sampling

7.1 *Lot Sample*—Divide the product into lots and take the lot sample as directed in Practice D 4354.

7.2 *Laboratory Sample*—Consider the units in the lot sample as the units in the laboratory sample for the lot to be

tested. Take for a laboratory sample a sample extending the full width of the panel drain, of sufficient length so that the requirements in 7.3 are met.

NOTE 1—This test method only addresses products with uniform (parallel and perpendicular) geometry. This procedure does not address products with other geometry.

7.3 The height of the drain sample tested shall be equal to the height of the drain in the field unless otherwise agreed to by the purchaser and manufacturer. The length of the drain sample shall be 298.5 mm (11.75 in.). The sample length shall be cut as close to or through a support post, or both, if possible, or trim the edge of the drain to ensure that no fabric is unsupported at the ends of the sample to reduce end effects. Thin plates of plexiglass (spacers) also may be used to insure a proper fit into the chamber.

NOTE 2—Spacers should not exceed a total thickness of 6.4 mm ( $1/4$  in.).

NOTE 3—False readings in core changes can occur due to changes occurring only at the end of the sample.

7.4 When sampling, the geotextile shall be cut approximately 19 mm ( $3/4$  in.) longer than the core, at both ends of the core. This length may have to be reduced for stiffer fabrics. This extra fabric length is specified to reduce end effects.

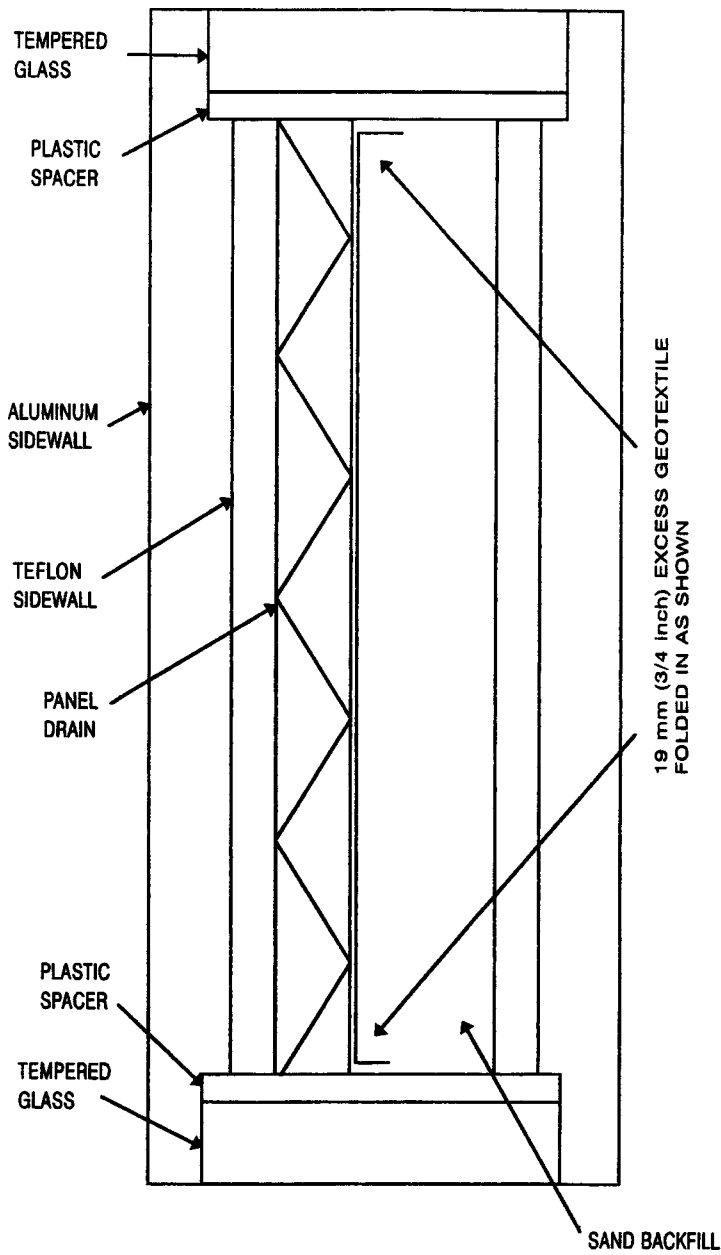

FIG. 2 Top View of Compression Chamber

TABLE 1 Backfill Gradation

| Sieve Size <sup>A</sup> | Percent Passing |
|-------------------------|-----------------|
| 9.5 mm (3/8 in.)        | 100             |
| No. 4                   | 90-100          |
| No. 16                  | 45-80           |
| No. 50                  | 5-25            |
| No. 100                 | 0-8             |

<sup>A</sup> Crushed sand may be accepted with a minimum sand equivalent of 70 provided the passing No. 40 sieve fraction of the sand is nonplastic.

NOTE 4—False readings in core change can occur due to fabric intrusion on the ends of the core. End effects could govern response.

7.5 The geotextile covering the core shall be intact. There shall not be any tears or punctures, and when the textile is normally glued to the core for a particular design, it shall remain glued for this test method.

## 8. Conditioning

8.1 Test the specimens in a laboratory having an air temperature of  $21 \pm 2^\circ\text{C}$  ( $70 \pm 4^\circ\text{F}$ ) and a relative humidity of 60 % - 70 %. The specimens shall be allowed to condition to laboratory temperature and moisture for a minimum of 12 h prior to testing.

## 9. Procedure

9.1 The plastic spacers are placed next to the tempered glass ends of the box. This helps prevent the sand from scratching the glass ends of the box. The plastic spacers may be considered expendable since it may become necessary to replace them after several tests due to scratching by the sand.

9.2 The sample is placed in an upright position in the compression box against one sidewall of the box. The sample

shall be oriented in the chamber in the same manner as recommended by the manufacturer to be placed in the field, with the inside walls of the chamber being considered, first, the pavement side of the trench, and second, the shoulder side of the trench. The sample shall be placed into the chamber in such a way that the maximum core area of the panel is visible through the ends of the box. If necessary, the samples shall be snugged into place with thin panes of plexiglass, 3.2 mm (0.125 in.) and 6.4-mm (0.25 in.) are recommended, to insure proper tightness on the walls of the chamber.

NOTE 5—The panes shall not be forced into place. This could cause compression or misalignment in the sample.

9.3 The 19 mm (¾ in.) excess geotextile at the ends of the core shall be lapped as shown in Fig. 2. This helps to prevent sand from flowing between the end of the core and the glass endwall and reduces end effects.

9.4 Pour the oven-dried sand into the compression box to a height of at least 101.6 mm (4 in.) above the top of the core of the panel. The sand shall be poured into the chamber from a bucket with the bottom edge of the bucket resting on the top of the chamber. Make no attempt to densify the sand. A rectangular bucket approximately the same width of the chamber 304.8 mm (12 in.) is recommended. The sample shall be held in place firmly by hand against the wall of the chamber while the backfill is being placed. Typical sand densities for this gradation will range from 1457.6 to 1585.8 kg/m<sup>3</sup> (91 to 99 lbs/ft<sup>3</sup>).

NOTE 6—This test method only evaluates the stability of the panel with dry sand. Panel stability will vary greatly with changes in sand moisture and density. The range of sand densities given above were not significant enough to impact results in this test method.

9.5 Smooth the surface of the sand to make it as level as possible.

9.6 Place the load plate, as described in Fig. 1, onto the sand surface, and then place the entire compression box into the testing machine.

9.7 With a scale, measure and record the height of the panel core within 1 mm (¼ in.).

9.8 With the light source shining through the open core from one glass end of the compression box, place a piece of tracing paper on the opposite end of the box and trace the open area of the core. End effects should be evaluated between tracings. If end effects are observed or backfill has flowed into the core that would reduce light transmission and give false readings of core area change, the test shall be abandoned.

9.9 Begin loading the sand backfill and core at a rate of 445-N (100 lb)/min (± 10 lb). When the load has reached 1112.5-N (250 ± 15 lb), hold the load constant, measure the height of the core, and repeat the step in 9.8.

9.10 After the step in 9.9 is completed, continue loading the sample at the same rate designated in 9.9 until the load reaches 2225-N (500 ± 20 lb). Repeat 9.8. Repeat the same procedures when the load reaches 3337.5-N (750 ± 30 lb) and 4450-N (1 000 ± 35 lb).

9.11 Remove the compression box from the testing machine. Remove the sand, the sample, and the plastic spacers.

9.12 Flush all of the remaining sand from the compression box. Use liberal amounts of water.

NOTE 7—**Caution:** Do not wipe the glass ends with a cloth or paper towel until certain all sand has been removed since this may scratch the glass.

9.13 Completely dry the interior of the compression box.

9.14 Repeat 9.1 through 9.4 using a new specimen.

9.15 Repeat 9.5 through 9.13.

## 10. Calculation

10.1 Calculate the decrease in the area of the core with increasing load and the decrease in the height of the core.

10.2 Determine vertical stress on the horizontal sand surface, which is located immediately under the loading plate, at each load level as follows:

$$\text{Stress} = (\text{Load}) / (\text{Area of the Loading Plate})$$

For Example:

$$\text{Stress} = (1112.5 \text{ N}) / (0.0284 \text{ m}^2) = 39\,172 \text{ Pa}$$

$$(\text{Stress} = (250 \text{ lb}) / (44 \text{ in.}^2) = 5.68 \text{ psi})$$

10.3 From the tracing made at each load level, use planimeter or digitizing equipment to determine open area of core at each load level.

10.4 Determine the percent change in area of the core at each load level as follows:

$$A_D = [(A_0 - A_L) / (A_0)] \times 100 \quad (1)$$

where:

$A_D$  = change in area (percent),

$A_0$  = initial area at zero load, and

$A_L$  = area at a particular load.

10.5 Plot percent change in core area ( $A_D$ ) as a function of stress for each load level.

10.6 Determine the percent change height ( $H_D$ ) as a function of stress at each load level.

10.7 Calculate percent change in height as follows:

$$H_D = [(H_I - H_L) / (H_I)] \times 100 \quad (2)$$

where:

$H_D$  = change in height (%),

$H_I$  = initial height of core, and

$H_L$  = height of core at a particular load.

10.8 Plot percent change in height ( $H_D$ ) as a function of stress at each load level.

## 11. Report

11.1 Report the following information:

11.1.1 The description of the type of geocomposite panel drain tested.

11.1.2 The date of test.

11.1.3 The percent change in core area at a stress level of 156.5 kPa (22.7 psi).

11.1.4 The percent change in height at a stress level of 156.5 kPa (22.7 psi).

11.1.5 Plot percent core area change and percent change in height as a function of stress.

11.1.6 A statement of any unusual occurrences or departures from the suggested procedures.

11.1.7 Machine type and date of last calibration.

## 12. Precision and Bias

12.1 *Precision*—The precision of the procedure in this test method is being evaluated.

12.2 *Bias*—The value of the compressive yield point of geosynthetics can be defined only in terms of a test method. When this test method is the defining method, measurements of the compressive yield point have no bias.

### 13. Keywords

13.1 compression; deformation; geocomposite; index test; panel drain

*The American Society for Testing and Materials takes no position respecting the validity of any patent rights asserted in connection with any item mentioned in this standard. Users of this standard are expressly advised that determination of the validity of any such patent rights, and the risk of infringement of such rights, are entirely their own responsibility.*

*This standard is subject to revision at any time by the responsible technical committee and must be reviewed every five years and if not revised, either reapproved or withdrawn. Your comments are invited either for revision of this standard or for additional standards and should be addressed to ASTM Headquarters. Your comments will receive careful consideration at a meeting of the responsible technical committee, which you may attend. If you feel that your comments have not received a fair hearing you should make your views known to the ASTM Committee on Standards, 100 Barr Harbor Drive, West Conshohocken, PA 19428.*