



Designation: D 5503 – 94 (Reapproved 1999)

Standard Practice for Natural Gas Sample-Handling and Conditioning Systems for Pipeline Instrumentation¹

This standard is issued under the fixed designation D 5503; the number immediately following the designation indicates the year of original adoption or, in the case of revision, the year of last revision. A number in parentheses indicates the year of last reapproval. A superscript epsilon (ϵ) indicates an editorial change since the last revision or reapproval.

1. Scope

1.1 This practice covers sample-handling and conditioning systems for typical pipeline monitoring instrumentation (gas chromatographs, moisture analyzers, and so forth). The selection of the sample-handling and conditioning system depends upon the operating conditions and stream composition.

1.2 This practice is intended for single-phase mixtures that vary in composition. A representative sample cannot be obtained from a two-phase stream.

1.3 *This standard does not purport to address all of the safety concerns, if any, associated with its use. It is the responsibility of the user of this standard to establish appropriate safety and health practices and determine the applicability of regulatory limitations prior to use.*

1.4 The values stated in SI units are to be regarded as standard. The values stated in English units are for information only.

2. Referenced Documents

2.1 ASTM Standards:

D 1142 Test Method for Water Vapor Content of Gaseous Fuels by Measurement of Dew-Point Temperature²

D 3764 Practice for Validation of Process Stream Analyzers³

2.2 Other Documents:

ANSI/API 2530 (AGA Report Number 3)⁴

AGA Report Number 8⁵

NACE Standard MR-01-75⁶

3. Terminology

3.1 Definitions:

3.1.1 *compressed natural gas*—natural gas compressed to approximately 3600 psi.

¹ This practice is under the jurisdiction of ASTM Committee D-3 on Gaseous Fuels and is the direct responsibility of Subcommittee D03.01 on Collection and Measurement of Gaseous Samples.

Current edition approved Feb. 15, 1994. Published April 1994.

² *Annual Book of ASTM Standards*, Vol 05.06.

³ *Annual Book of ASTM Standards*, Vol 05.02.

⁴ Available from American National Standards Institute, 11 W. 42nd St., 13th Floor, New York, NY 10036.

⁵ Available from American Gas Association, 1515 Wilson Blvd., Arlington, VA 22209.

⁶ Available from National Association of Corrosion Engineers, 1440-T S. Creek Dr., Houston, TX 77084.

3.1.2 *density*—mass per unit volume of the substance being considered.

3.1.3 *dew point*—the temperature and pressure at which the first droplet of liquid forms from a vapor.

3.1.4 *lag time*—time required to transport the sample to the analyzer.

3.1.5 *natural gas*—mixture of low molecular weight hydrocarbons obtained from petroleum-bearing regions.

3.1.6 *sample probe*—device to extract a representative sample from the pipeline.

3.1.7 *system turnaround time*—the time required to transport the sample to the analyzer and to measure the desired components.

4. Significance and Use

4.1 A well-designed sample-handling and conditioning system is essential to the accuracy and reliability of pipeline instruments. Approximately 70 % of the problems encountered are associated with the sampling system.

5. Selection of Sample-Handling and Conditioning System

5.1 The sample-handling and conditioning system must extract a representative sample from a flowing pipeline, transport the sample to the analyzer, condition the sample to be compatible with the analyzer, switch sample streams and calibration gases, transport excess sample to recovery (or disposal), and resist corrosion by the sample.

5.2 The sample probe should be located in a flowing pipeline where the flow is fully developed (little turbulence) and where the composition is representative. In areas of high turbulence, the contaminants that normally flow along the bottom or the wall of the pipeline will form aerosols.

5.3 The purpose of the sample probe is to extract a representative sample by obtaining it near the center of the pipeline where changes in stream composition can be quickly detected.

5.3.1 The tip in the sample probe should be positioned in the center one third of the pipeline away from the pipeline wall where large particles accumulate.

5.3.2 The probe should be a minimum of five pipe diameters from any device that could produce aerosols or significant pressure drop.

5.3.3 The sample probe should not be located within a defined meter tube region (see ANSI/API 2530 AGA Report

Number 3 and AGA Report Number 8 for more information).

5.3.4 The sample probe should be mounted vertically from the top on horizontal pipelines. The sample probe should not be located on vertical pipelines.

5.4 The sampling-handling system must transport the sample to the analyzer and dispose of excess sample. Since the sampling point and the analyzer may be separated by some distance, the time required to transport the sample to the analyzer can contribute significantly to the system turnaround time.

5.4.1 The analyzer should be located as close to the sampling point as is practical to minimize the sample lag time.

5.4.2 The sample-handling system should be equipped with a full open ball valve and a particular filter.

5.5 The sizing of the sample transport line will be influenced by a number of factors:

5.5.1 The sample point pressure and the location of the pressure reduction regulator.

5.5.2 The acceptable lag time between the sample point and the analyzer.

5.5.3 The requirements of the analyzer such as flow rate, pressure, and temperature for the analysis. For multistream systems, the sample line and associated manifold tubing should be flushed with sufficient sample to assure a representative sample of the selected stream.

5.5.4 The presence of sample-conditioning elements will contribute to the lag time and must be considered in the calculation of the minimum sample flow rate.

5.5.4.1 Each element could be considered as an equivalent length of sample line and added to the length of line from the sample point to the analyzer.

5.5.4.2 The purge time of each element is calculated as the time necessary for five volumes of sample to flow through the element.

5.5.5 A vapor sample must be kept at least 10°C above the hydrocarbon dew point temperature to prevent condensation of the sample. The sample line should be heat traced and insulated when appropriate.

5.5.5.1 For compressed natural gas (CNG), the pressure must be reduced in two stages to avoid condensation of liquids caused by the Joule-Thompson effect. In a heated zone at approximately 50°C, the pressure should be dropped to approximately 10 MPa (1500 psig) and then to a suitable pressure for the analyzer. Any conditioning of the sample must be completed in the heated zone.

5.5.5.2 The sample line from the heated zone to the analyzer must be heat traced to avoid partial condensation of the sample.

6. Apparatus

6.1 The following are common components of a sample-handling and conditioning system (see Refs (1) and (2)⁷ for more information).

6.1.1 Ball valves, needle valves, and solenoid valves are typically used for stream switching, sample shutoff, calibration gas introduction, or sample vent and bypass systems.

⁷ The boldface numbers in parentheses refer to the list of references at the end of this practice.

6.1.2 Most pipeline samples require some filtering. Since all filter elements eventually plug, they should be replaced on a regular maintenance schedule. There are several types of filter designs.

6.1.2.1 *In-Line Filter*—All of the sample passes through an in-line filter. The active filter elements are available in Teflon polypropylene, copolymer, or stainless steel. (See Fig. 1.)

6.1.2.2 *Bypass Filter*—Only a small portion of the sample passes through a bypass filter, while a majority of the sample passes across its surface keeping it clean. The active filter element is either a disposable cartridge or a reusable sintered metal element. (See Fig. 2.)

6.1.2.3 *Cyclone Filter*—The cyclone filter is a centrifugal cleanup device. The sample enters at high velocity tangentially to the wall of a cylindrical-shaped vessel with a conical-shaped bottom. The centrifugal force developed by the spinning action of the gas as it follows the shape of the vessel forces particles and droplets to the wall where they are removed through the vent flow. (See Fig. 3.)

6.1.2.4 *Coalescing Filter*—Coalescers, also known as membrane separators, are used to force finely divided liquid droplets to combine into larger droplets so they can be separated by gravity. The design of the coalescer body forces the heavier phase out the bottom and the lighter phase out the top. The flow rates out the top and the bottom are critical for proper operation. (See Fig. 4.)

(a) Since this process removes part of the sample, the impact on sample composition must be considered.

(b) The coalescer should be located immediately upstream from the analyzer.

6.1.3 The combination condenser/separator is used to remove condensable liquids from a vapor sample. The sample enters the separator and cools as it passes through the device. The condensed liquid phase is separated by gravity and removed from the bottom of the separator. (See Fig. 5.)

6.1.3.1 Since this process removes part of the sample, the impact on sample composition must be considered.

6.1.3.2 The condenser/separator should be located immediately upstream from the analyzer.

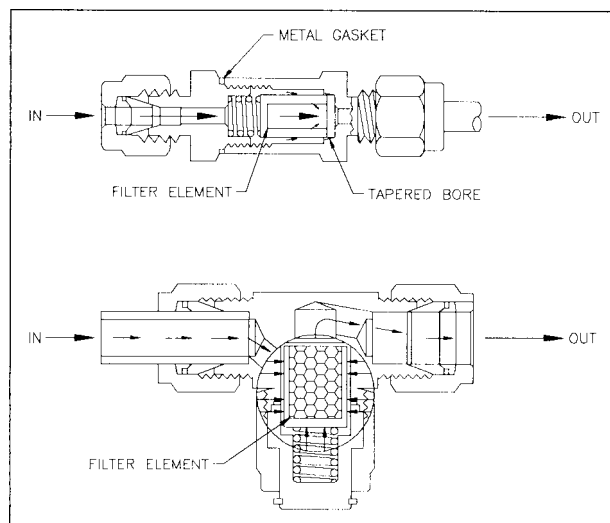

FIG. 1 Cross Section of Common In-Line Filters

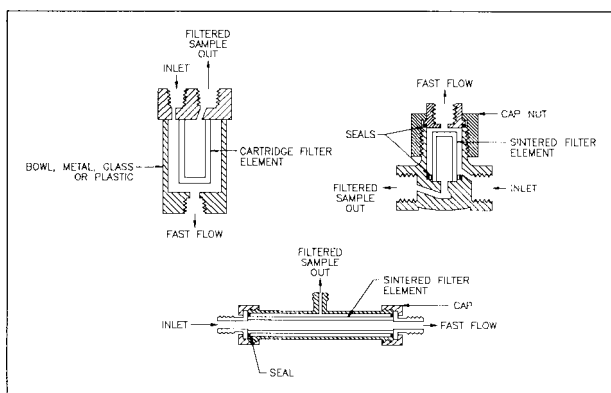

FIG. 2 Cross Section of Common Bypass Filters

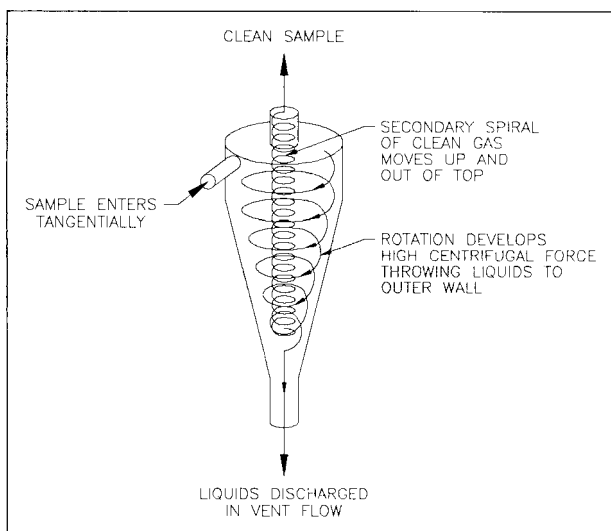

FIG. 3 Cyclone Filter/Centrifugal Filter

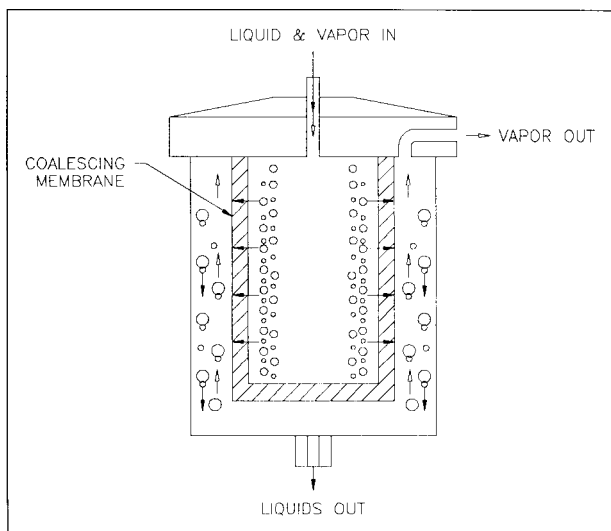

FIG. 4 Coalescing Filter

6.1.4 Pressure regulators are required to reduce and regulate pressure between the sampling point and the analyzer. The regulator must be constructed of the proper materials to allow for the corrosive nature of the sample.

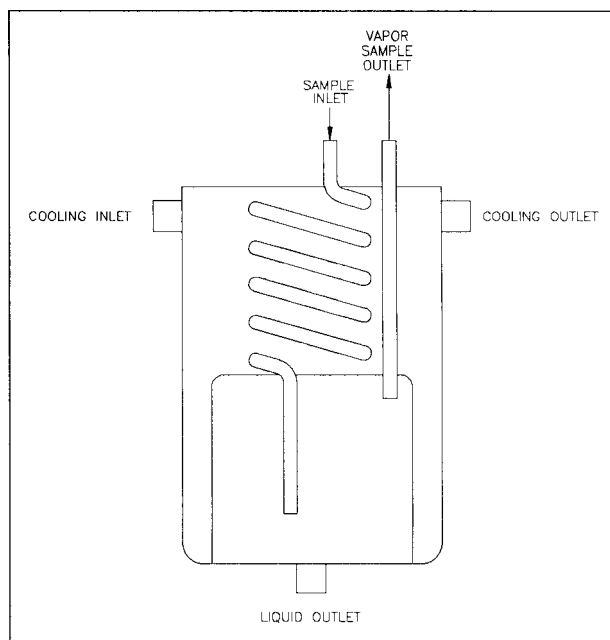

FIG. 5 Combination Condenser/Separator

6.1.4.1 A combination sample probe and regulator with thermal fins around the probe could be used to minimize the Joule-Thompson effect.

6.1.5 Pressure gages should be installed downstream of the pressure regulator. Since the sensing element of these devices (Bourdon tube) consists of unswept volume, the pressure gage should be installed either in a bypass line or after the analyzer.

6.1.6 Rotameters are used to indicate the flow rate of the sample. A typical rotameter consists of a ball or float mounted in a tapered tube. The reading is proportional to fluid density and viscosity which may vary with the composition of the fluid.

6.1.6.1 The rotameter should be located downstream of the analyzer and used as an indicator of flow and system cleanliness. A clean tube and a freely moving ball is an indicator of a clean system.

6.1.7 Typical natural gas sample system. (See Fig. 6.)

6.1.8 Compressed natural gas sample system. (See Fig. 7.)

7. Materials

7.1 Many of the common sample system components are constructed of metals such as 316 stainless steel, Hastelloy, and Monel and compatible plastics such as Kel-F, Teflon, and Kynar.

7.1.1 The sample-handling and conditioning system should be constructed of material capable of resisting corrosion from the sample and the environment.

7.1.1.1 Sample system components should be chosen carefully to avoid corrosion or adsorption by the sample.

7.1.1.2 If sour gas (gas that contains hydrogen sulfide or carbon dioxide, or both) is suspected, NACE Standard MR-01-75 should be followed.

7.2 The sample-handling and conditioning system should contain the sample under the most severe conditions of pressure, temperature, and vibration that the pipeline will experience during normal and upset conditions.

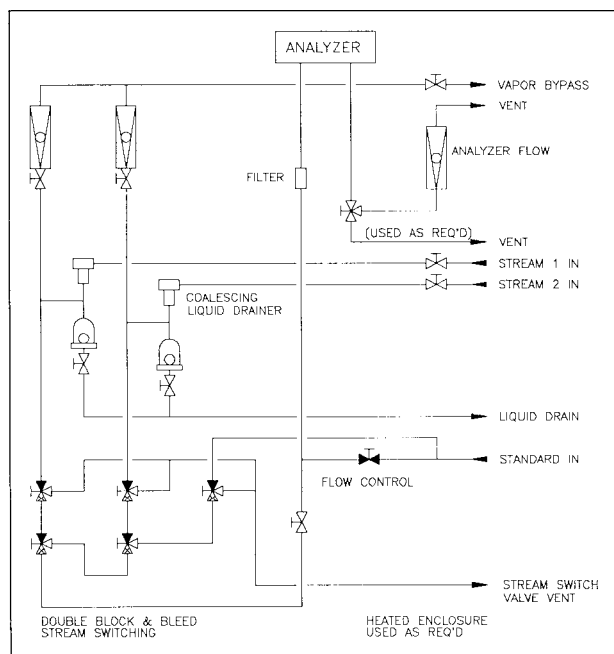

FIG. 6 Typical Natural Gas Sampling System

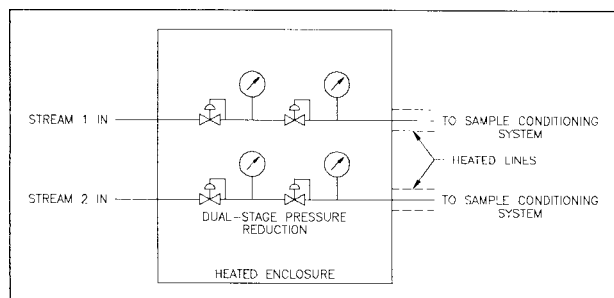

FIG. 7 Pressure Reduction System for Compressed Natural Gas (CNG)

8. Calculation

8.1 Sample transport time, or lag time, t_{lag} , is a function of the sample line length and diameter, the absolute pressure in the line, and the sample flow rate. Lag time is calculated as follows:

$$t_{lag} = \frac{VL(P + P_{atm})}{F_a P_{atm}} \quad (1)$$

where:

- t_{lag} = sample transport time, min;
- V = volume of sample per unit length, cm^3/m ;
- L = equivalent length of sample length, m;
- P = sample pressure, N/m^2 ;
- P_{atm} = atmospheric pressure, N/m^2 ; and
- F_a = actual average flow rate of the sample, cm^3/min .

8.1.1 *Example*—Consider a sample point located 100 ft away from an analyzer requiring 200 cm^3/min of sample. Using standard conditions and 0.19-in. inside diameter tubing, a lag time of 75 min can be calculated. By increasing the sample flow to 2200 cm^3/min and splitting the excess sample to a high-speed loop, the lag time decreases to 7.5 min. The sample pressure should be reduced at the analyzer.

8.1.2 Reducing the pressure at the sample point rather than

the analyzer can also decrease the lag time. For a pressure reduction from 400 to 40 psig, the sample flow should be 2000 cm^3/min to compensate for the increase in sample volume. (See Fig. 8.)

8.2 The equivalent length of sample line is calculated by the following expression (see Ref (3) for more information):

$$L = L_d + L_{eq} \quad (2)$$

where:

- L = equivalent length of sample line, m;
- L_d = length of sample line, m; and
- L_{eq} = equivalent length of valves and fittings, m.

8.3 Calculation of sample line size is a trial and error process:

8.3.1 Select a sample line size that meets the flow rate needs of the analyzer.

8.3.2 Calculate the Reynold's number, the ratio of inertial-to-viscous forces by:

$$R_e = \frac{\rho \mu d}{\eta} \quad (3)$$

where:

- R_e = Reynold's number;
- ρ = fluid density, Kg/m^3 ;
- μ = fluid velocity, m/s;
- d = diameter of the pipe, m; and
- η = viscosity of the fluid, Ns/m^2 .

8.3.3 Calculate the pressure drop using Darcy's equation (see (3) for more information):

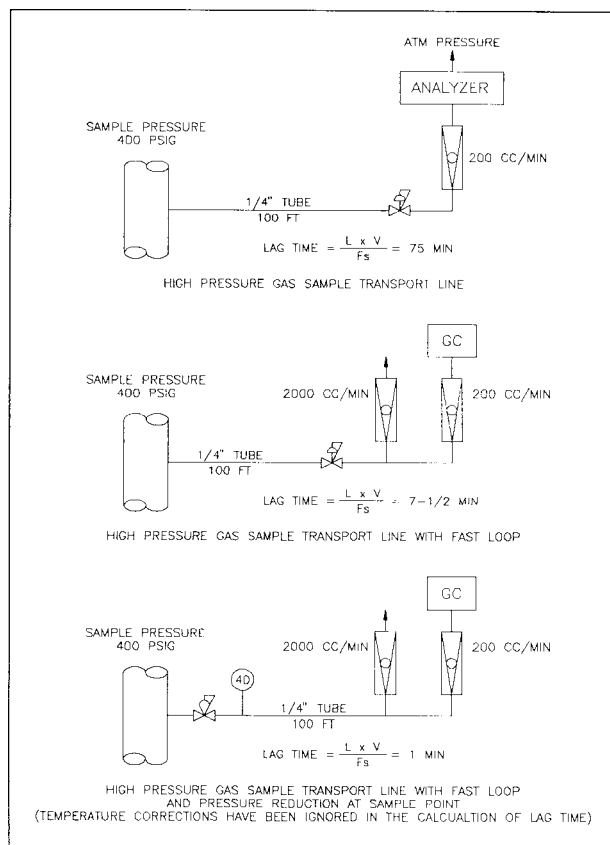

FIG. 8 Example Calculations of Lag Time

 **D 5503**

$$dp = \frac{f_p L u^2}{2 d g} \quad (4)$$

where:

- dp = pressure drop in the line, N/m²;
- f = frictional factor from Moody's tables;
- ρ = fluid density, Kg/m³;
- L = equivalent length of sample line, m;
- u = velocity of the fluid, m/s;
- d = diameter of the line, m; and
- g = acceleration of gravity, 9.81 m/s².

8.3.4 The available pressure drop should be compared with the calculated pressure drop. If the calculated pressure drop is too great, then select a larger sample line and repeat lag time, equivalent length, and pressure drop calculations.

8.3.5 The majority of sample transport problems are solved by application of prior experience and by use of tables relating velocity to pressure drop for different sample line diameters (see Refs (4) and (5) for more information).

8.4 The dew point calculation relies on the use of distribution coefficients, K_i , which are defined as the ratio of the mole fraction of the component in the vapor phase, Y_i , to the mole fraction in the liquid phase, x_i .

$$K_i = \frac{Y_i}{x_i} \quad (5)$$

8.4.1 Whenever possible, dew point should be calculated using a physical properties software package. Dew point can be calculated without the aid of a computer by the following procedure:

8.4.1.1 Assume a dew point temperature. Using a DePriester chart, determine the K at the highest pressure present in the sample line and the assumed dew point for each component in the sample (see Ref (6) for more information).

8.4.1.2 Calculate the mole fraction, y , for each component in the vapor phase.

8.4.1.3 Calculate the mole fraction, x , for each component in the liquid phase. At the dew point, the summation of the x_i s should be between 0.95 and 1.0.

8.4.2 The dew point calculation depends upon the accuracy of the stream composition. Small errors in the composition (especially in the heavier hydrocarbons) will cause large errors in the hydrocarbon dew point.

8.4.3 The dew point could be determined using a Bureau of Mines Type chilled mirror hygrometer (see Test Method D 1142 for more information).

9. Keywords

- 9.1 natural gas; pipeline instrumentation

REFERENCES

- (1) Cornish, D. C., Jepson, G., and Smarthwaite, M. J., *Sampling Systems for Process Analyzers*, London: Butterworth, 1981.
- (2) Annino, R. and Villalobos, R., *Process Gas Chromatography*, ISA Research Triangle Park, NC, 1992.
- (3) "Flow of Fluids through Valves, Fittings and Pipe," Technical Paper No. 410, Chicago, IL: Crane Co., 1978.
- (4) Moody, L. F., "Friction Factors for Pipe Flow," *Trans. Am. Soc. Mech. Engrs.*, **66**: 671-678, 1944.
- (5) Clevevtt, K. J., *Process Analyzer Technology*, John Wiley and Sons, New York, 1986.
- (6) DePriester, K., *Chem. Eng. Progr. Symp. Ser. 7*, **49**:1, 1953.

The American Society for Testing and Materials takes no position respecting the validity of any patent rights asserted in connection with any item mentioned in this standard. Users of this standard are expressly advised that determination of the validity of any such patent rights, and the risk of infringement of such rights, are entirely their own responsibility.

This standard is subject to revision at any time by the responsible technical committee and must be reviewed every five years and if not revised, either reapproved or withdrawn. Your comments are invited either for revision of this standard or for additional standards and should be addressed to ASTM Headquarters. Your comments will receive careful consideration at a meeting of the responsible technical committee, which you may attend. If you feel that your comments have not received a fair hearing you should make your views known to the ASTM Committee on Standards, at the address shown below.

This standard is copyrighted by ASTM, 100 Barr Harbor Drive, PO Box C700, West Conshohocken, PA 19428-2959, United States. Individual reprints (single or multiple copies) of this standard may be obtained by contacting ASTM at the above address or at 610-832-9585 (phone), 610-832-9555 (fax), or service@astm.org (e-mail); or through the ASTM website (www.astm.org).