



Designation: D 4493 – 9403

## Standard Test Method for Solidification Point of Bisphenol A (4,4'-Isopropylidenediphenol)<sup>1</sup>

This standard is issued under the fixed designation D 4493; the number immediately following the designation indicates the year of original adoption or, in the case of revision, the year of last revision. A number in parentheses indicates the year of last reapproval. A superscript epsilon ( $\epsilon$ ) indicates an editorial change since the last revision or reapproval.

<sup>1</sup> This test method is under the jurisdiction of ASTM Committee D-16 on Aromatic Hydrocarbons and Related Chemicals and is the direct responsibility of Subcommittee D16.06 on Oxygenated Aromatics.

Current edition approved April 15, 1994; Jan. 10, 2003. Published June 1994; March 2003. Originally published as D 4493 – 85; approved in 1985. Last previous edition approved in 1994 as D 4493 – 894.

### 1. Scope

1.1 This test method describes the procedure for determination of the solidification point of 4,4'-isopropylidene diphenol, commercially known as bisphenol A, between 150 and 157°C.

1.2 The following applies to all specified limits in this standard: For purposes of determining conformance with this standard, an observed value or a calculated value shall be rounded off “to the nearest unit” in the last right-hand digit used in expressing the specification limit, in accordance with the rounding-off method of Practice E 29.

1.3 *This standard does not purport to address all of the safety concerns, if any, associated with its use. It is the responsibility of the user of this standard to establish appropriate safety and health practices and determine the applicability of regulatory limitations prior to use. test method.* For specific hazard statements, see Section 9.

### 2. Referenced Documents

#### 2.1 ASTM Standards:

D 1493 Test Method for Solidification Point of Industrial Organic Chemicals<sup>2</sup>

D 4297 Practice for Sampling and Handling Bisphenol A (4,4'-Isopropylidenediphenol)<sup>2</sup>

E 1 Specification for ASTM Thermometers<sup>3</sup>

E 29 Practice for Using Significant Digits in Test Data to Determine Conformance with Specifications<sup>4</sup>

E 77 Test Method for Inspection and Verification of Thermometers<sup>3</sup>

E 691 Practice for Conducting an Interlaboratory Study to Determine the Precision of a Test Method<sup>4</sup>

#### 2.2 Other Document:

OSHA Regulations, 29 CFR, paragraphs 1910.1000 and 1910.1200<sup>5</sup>

### 3. Terminology

#### 3.1 Definitions:

3.1.1 *solidification point*—the temperature at which the liquid phase of a substance is in approximate equilibrium with a relatively small amount of the same substance in its solid phase.

### 4. Summary of Test Method

4.1 Bisphenol A is melted, and then cooled slowly with constant agitation. When crystallization begins, and super-cooling occurs, the temperature falls to a minimum, rises to a maximum, and then falls again. The maximum temperature attained after crystallization begins is the solidification point of bisphenol A.

### 5. Significance and Use

5.1 The solidification point of bisphenol A is a direct indication of its purity, although it gives no information as to the nature of any impurities present.

<sup>2</sup> Annual Book of ASTM Standards, Vol 06.04.

<sup>3</sup> Annual Book of ASTM Standards, Vol 14.03.

<sup>4</sup> Annual Book of ASTM Standards, Vol 14.02.

<sup>5</sup> Available from Superintendent of Documents, U.S. Government Printing Office, Washington, DC 20402.

5.2 High purity bisphenol A has a solidification point of approximately 157°C.  
 5.3 This test method can be used for internal quality control or for setting specifications.

**6. Interference**

6.1 Bisphenol A that is not stored or packaged properly may adsorb moisture. Adsorbed moisture will lower the solidification point.

**7. Apparatus**

7.1 *Nessler Tubes*, borosilicate, 100 mL, short form, 32-mm diameter.  
 7.2 *Electric Heat Block*, thermostatically controlled, capable of reaching 170°C; having flat-bottom holes 34 mm in diameter by 172 mm deep.

NOTE 1—A suitable size block is 100 by 110 by 175 mm high, and made of aluminum.  
 NOTE 2—A thermostatically controlled hot oil bath may be used.

7.3 *Erlenmeyer Flask*, 500-mL.

NOTE 3—The melted sample may be cooled in an air jacket-cooling bath, as specified in Test Method D 1493.

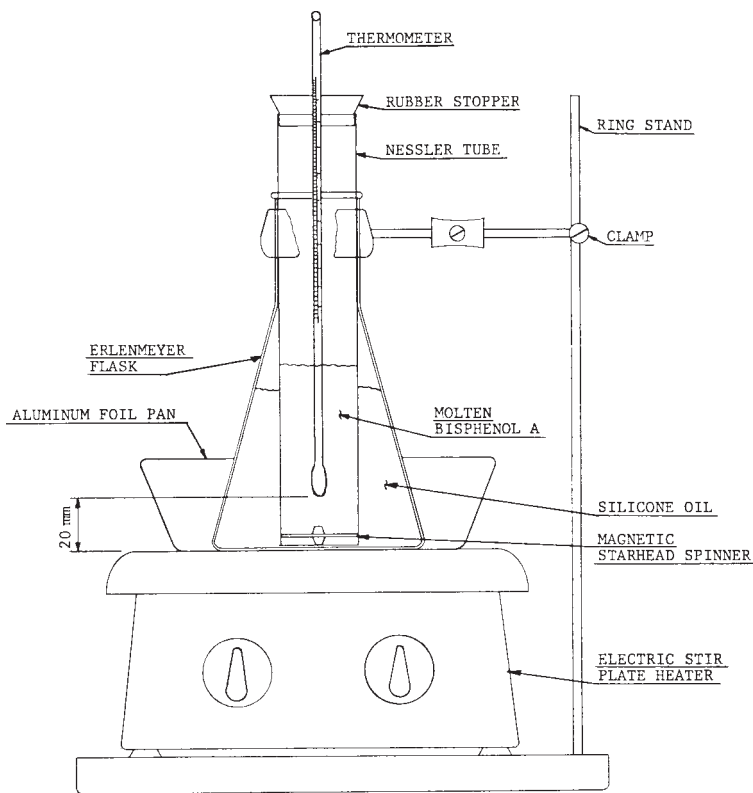

**FIG. 1 Bisphenol A Solidification Point Apparatus**

7.4 *Thermometer*—ASTM 102C, having a range from 123 to 177°C and conforming to the requirements for thermometer 102C as prescribed in Specification E 1.

NOTE 4—Thermometers should be calibrated in accordance with Test Method E 77 or calibrated from 154 to 157°C versus an NBS thermometer or platinum resistance thermometer. Preferably, thermometers should be calibrated and certified by a thermometer manufacturer. An alternative thermometer is a platinum resistance thermometer with digital read-out.

7.5 *Electric Heater*, stir plate, capable of reaching 150°C.

7.6 *Magnetic Spinner*, starhead.

NOTE 5—A wire stirrer, as specified in Test Method D 1493, may be used.

7.7 *Chloroprene Rubber Stopper*, number 6, with hole to fit thermometer. If wire stirrer is used, an additional hole is needed.

NOTE 6—Stoppers made of cork or other materials should not be used.

7.8 *Ring Stand and Clamp*.

## 8. Reagents and Materials

8.1 *Methyl Silicone Oil*, suitable for continuous use at 200°C.

## 9. Hazards

9.1 Consult current OSHA Regulations and, supplier's Material Safety Data Sheets, and local regulations for all materials used in this test method.

9.2 When handling molten solids in open tubes, adequate ventilation must be provided and proper protection should be used to prevent thermal burns. It is preferable to perform this test in a fume hood.

## 10. Sampling

10.1 Sample the material in accordance with Practice D 4297.

## 11. Procedure

11.1 Place a Nessler tube, filled with bisphenol A, and containing the magnetic spinner, the stopper, and thermometer, in an electric heat block, preheated to  $170 \pm 5^\circ\text{C}$ , to melt bisphenol A.

NOTE 7—The solidification point is determined on the specimen as received, with no drying procedure.

11.2 As the bisphenol A melts, add more to the Nessler tube, if necessary, so that the immersion requirement of the thermometer will be met. It takes approximately 30 to 45 min to melt enough bisphenol A to run the test. In order to minimize the loss of volatile components, it is advisable to begin the solidification point determination within 5 min after the bisphenol A is molten.

11.3 After the bisphenol A has melted, remove the Nessler tube from the heat block and place in the Erlenmeyer flask, which has been clamped to a ring stand (see Fig. 1). It may be necessary to wrap aluminum foil around the top portion of the Nessler tube, before placing in the Erlenmeyer flask, to prevent the tube from turning in the flask. The flask contains 400 mL of silicone oil that has been preheated to  $140 \pm 2^\circ\text{C}$ , and is on a heater-stir plate. It is advisable to set the flask in a small aluminum foil pan to catch the oil in the event of a flask failure.

11.4 Submerge the thermometer to the immersion mark and ensure that the bulb of the thermometer is approximately 20 mm above the bottom of the Nessler tube, clearing the magnetic spinner.

11.5 Start the magnetic spinner stirring at a rate to create a vortex, and continue stirring until the liquid becomes solid enough to prevent the spinner from stirring. The cooling rate should be adjusted to maintain a constant temperature for about 3 min. The cooling rate may or may not be critical, depending upon the product purity.

11.6 Observe and record the thermometer readings at 30-s intervals to the nearest  $0.1^\circ\text{C}$  until the temperature rises from the minimum, due to super cooling, to a maximum, and finally begins to drop. Further stirring will be impossible at this point. The maximum temperature after crystallization begins is the solidification point.

NOTE 8—Taking temperature readings 30 s apart will ensure against mistaking a temporary plateau for the maximum temperature. Plotting the temperature readings against time will also help to identify a temporary plateau.

11.7 Correct the observed solidification point for the calibration of the thermometer.

## 12. Report

12.1 Report the solidification point as the maximum temperature attained after crystallization begins. Report to the nearest  $0.1^\circ\text{C}$ .

## 13. Precision and Bias

13.1 *Precision*—The following criteria should be used to judge the acceptability (95 % confidence level) of results obtained by this test method. An interlaboratory study<sup>6</sup> was conducted by four laboratories to determine solidification points on three separate materials. Duplicates were run by each laboratory on two different days. ~~S~~ Results of the  $\bar{F}$  interlaboratory study were calculated using Practice E 691.

13.1.1 *Repeatability*—Results submitted by the same laboratory should not be considered suspect unless they differ by more than  $0.5^\circ\text{C}$ . On the basis of test error alone, the difference between two test results obtained in the same laboratory on the same material on the same day will be expected to exceed this value only 5 % of the time.

13.1.2 *Reproducibility*—Results submitted by each of two laboratories should not be considered suspect unless they differ by more than  $1.8^\circ\text{C}$ . On the basis of test error alone, the difference between two test results obtained in different laboratories on the same material will be expected to exceed this value only 5 % of the time.

<sup>6</sup>Fisher Scientific Co., No. 7-052 B.

<sup>6</sup>Supporting data are available from the local Fisher supplier, or its equivalent, has been found to be satisfactory for this purpose. ASTM International Headquarters, Request RR: D16-1008.

13.2 *Bias*—No statement is made about bias of the test method since there is no absolute method available as a referee method.

#### **14. Keywords**

14.1 bisphenol-A; isopropylidenediphenol; solidification point

*ASTM International takes no position respecting the validity of any patent rights asserted in connection with any item mentioned in this standard. Users of this standard are expressly advised that determination of the validity of any such patent rights, and the risk of infringement of such rights, are entirely their own responsibility.*

*This standard is subject to revision at any time by the responsible technical committee and must be reviewed every five years and if not revised, either reapproved or withdrawn. Your comments are invited either for revision of this standard or for additional standards and should be addressed to ASTM International Headquarters. Your comments will receive careful consideration at a meeting of the responsible technical committee, which you may attend. If you feel that your comments have not received a fair hearing you should make your views known to the ASTM Committee on Standards, at the address shown below.*

*This standard is copyrighted by ASTM International, 100 Barr Harbor Drive, PO Box C700, West Conshohocken, PA 19428-2959, United States. Individual reprints (single or multiple copies) of this standard may be obtained by contacting ASTM at the above address or at 610-832-9585 (phone), 610-832-9555 (fax), or [service@astm.org](mailto:service@astm.org) (e-mail); or through the ASTM website ([www.astm.org](http://www.astm.org)).*