



Designation: D 4151 – 92 (Reapproved 1998)^{ε1}

Standard Test Method for Flammability of Blankets¹

This standard is issued under the fixed designation D 4151; the number immediately following the designation indicates the year of original adoption or, in the case of revision, the year of last revision. A number in parentheses indicates the year of last reapproval. A superscript epsilon (ε) indicates an editorial change since the last revision or reapproval.

^{ε1} NOTE—Editorial changes were made to footnotes 5, 6, and 7 in December 1998.

1. Scope

1.1 This test method provides a means to identify blanket fabrics which ignite easily and propagate flame across the surface.

1.2 This test method specifies the procedures described in the “Voluntary Blanket Flammability Standard” which has been used by the blanket industry in the United States since 1972.

1.3 *This test method should be used to measure and describe the properties of materials, products, or assemblies in response to heat and flame under controlled laboratory conditions and should not be used to describe or appraise the fire hazard or fire risk of materials, products, or assemblies under actual fire conditions. However, results of this test may be used as elements of a fire risk assessment which takes into account all of the factors which are pertinent to an assessment of the fire hazard of a particular end use.*

1.4 *This standard does not purport to address all of the safety problems, if any, associated with its use. It is the responsibility of the user of this standard to establish appropriate safety and health practices and determine the applicability of regulatory limitations prior to use.*

2. Referenced Documents

2.1 ASTM Standards:

- D 123 Terminology Relating to Textiles²
- D 1230 Test Method for Flammability of Apparel Textiles²
- D 1776 Practice for Conditioning Textiles for Testing²
- D 3411 Test Methods for Flammability of Textile Materials³

2.2 Federal Specification:

NNN-P-40b⁴

3. Terminology

3.1 Definitions:

3.1.1 *blanket, n—for bedding, an unquilted fabric covering designed primarily to provide thermal insulation.*

¹ This test method is under the jurisdiction of ASTM Committee D-13 on Textiles and is the direct responsibility of Subcommittee D13.52 on Flammability.

Current edition approved July 30, 1982. Published September 1982. Originally published as D 4151 – 82. Last previous edition D 4151 – 82.

² *Annual Book of ASTM Standards*, Vol 07.01.

³ Discontinued, see 1980 *Annual Book of ASTM Standards*, Part 32.

⁴ Available from Standardization Documents Order Desk, Bldg. 4 Section D, 700 Robbins Ave., Philadelphia, PA 19111-5094, Attn: NPODS.

3.1.1.1 *Discussion*—Blankets may be made by any textile process from various types of fibers and may or may not have a raised fiber surface. Construction may be woven, knitted, flocked, or nonwoven.

3.1.1.2 *Discussion*—Electric blankets include resistance heating wires and can provide heat as well as thermal insulation.

3.1.2 *flammability, n*—those characteristics of a material that pertain to its relative ease of ignition and relative ability to sustain combustion.

NOTE 1—In this test, evidence of ignition is shown by discoloration, charring, or burning of the paper monitor.

3.1.3 *ignition, n*—initiation of combustion.

3.2 For definitions of other textile terms used in this test method, refer to Terminology D 123.

4. Summary of Test Method

4.1 Specimens cut from the blanket fabric are prepared by brushing if they have a raised fiber surface and by drying. The dried specimen is held in a special apparatus, a standardized flame is applied to the surface for a specified time under controlled conditions, and burning, charring, or discoloration of a paper monitor is noted. Two classes of flammability are described.

4.1.1 A burn of sufficient intensity to discolor a paper monitor in specified contact with the surface of the test specimen indicates ignition of the blanket surface (see 11.4.1).

5. Significance and Use

5.1 This test method for the determination of the flammability of blankets is considered satisfactory for acceptance testing of commercial shipments of blankets since this test method has been used extensively in the trade for acceptance testing.

5.2 This test method may be used to evaluate electric blanket fabric, but tests should be performed on the fabric itself without the resistance heating wires inserted.

5.3 All fabrics made of natural or regenerated cellulose, as well as many made from other natural or synthetic fibers, are combustible. Some combustible fabrics when used for blankets are potentially dangerous to the user because of the ease of ignition, rapidity, and intensity of burning. The first characteristic can be judged with the aid of the flammability tester.

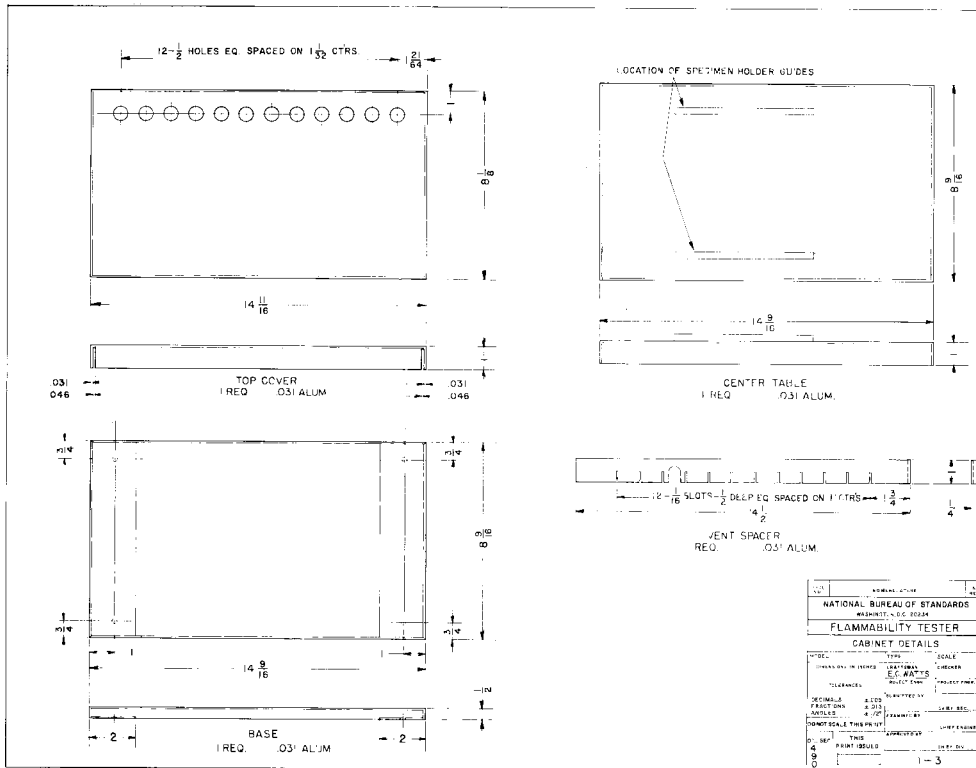

FIG. 3 Flammability Tester (Additional Cabinet Details)

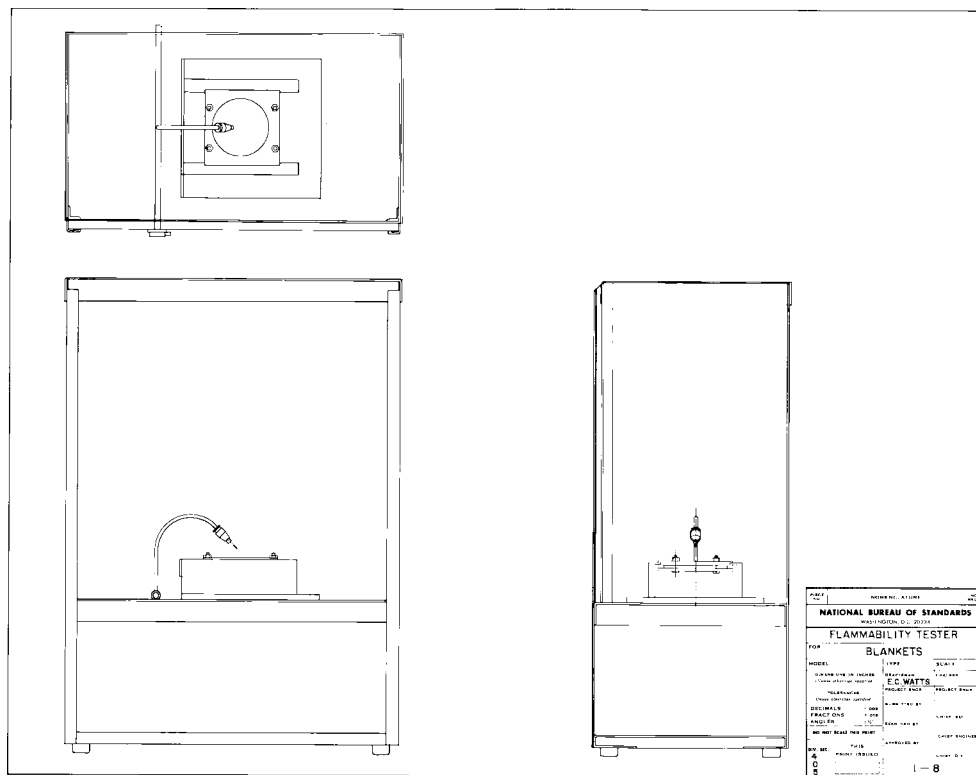

FIG. 4 Flammability Tester Arrangement

control the time of flame impingement on the specimen to 1 ± 0.05 s. A system found to be suitable is:

6.1.1.1 Adjustable electronic timer controlling a burner solenoid to activate the burner mechanism.

6.1.1.2 *Electronic Counter* (digital clock reading to 0.01 s), started by a switch that is activated by the burner mechanism when the burner is in the position to impinge flame on the

specimen and is stopped when the burner retracts from the specimen.

NOTE 2—A flammability tester made for use in Test Method D 1230 has to be modified when used with Test Method D 4151 by changing the burner, specimen holder, and timing mechanism.

6.2 *Specimen Holder and Base*, as shown in Figs. 5 and 6.

6.2.1 The base shall be mounted on the floor of the cabinet approximately center on both axes. The position of the base shall be adjustable along both the length and width axes of the flammability test cabinet.

6.3 *Burner*, as shown in Fig. 7.

6.3.1 The burner is a No. 18 hypodermic needle. The needle is cut off below the ferrule approximately 1.5 mm (1/16 in.) long. One end of an 3-mm (1/8-in.) OD copper tube approxi-

mately 200 mm (8 in.) long is soldered or cemented with epoxy adhesive into the ferrule of the hypodermic needle. The other end is soldered to the gas feeding tube which is part of the mechanism used to impinge the flame on the specimen (see Figs. 1-7).

6.4 *Methane*, technical grade (at least 97 % pure).

6.4.1 The gas line to the burner shall be equipped with a needle valve to control the flame length.

6.4.2 Gas shall be supplied to the burner at a pressure of 17.2 ± 3.4 kPa (2.5 ± 0.5 psig) at the needle valve inlet.

6.5 *Brushing Device*, as shown in Fig. 8 and described in A1.2 of Test Method D 1230, except that the brush rests on the carriage vertically with a pressure of 75 ± 10 g instead of 150 g as described in A1.2.1 of Test Method D 1230.

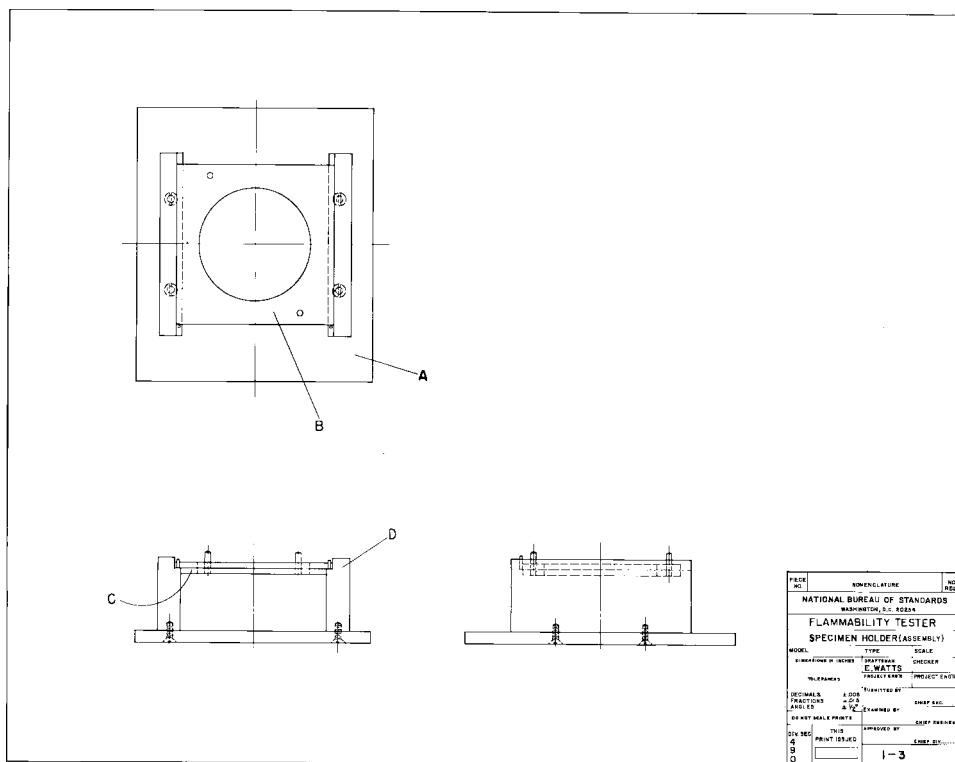

FIG. 5 Specimen Holder Assembly

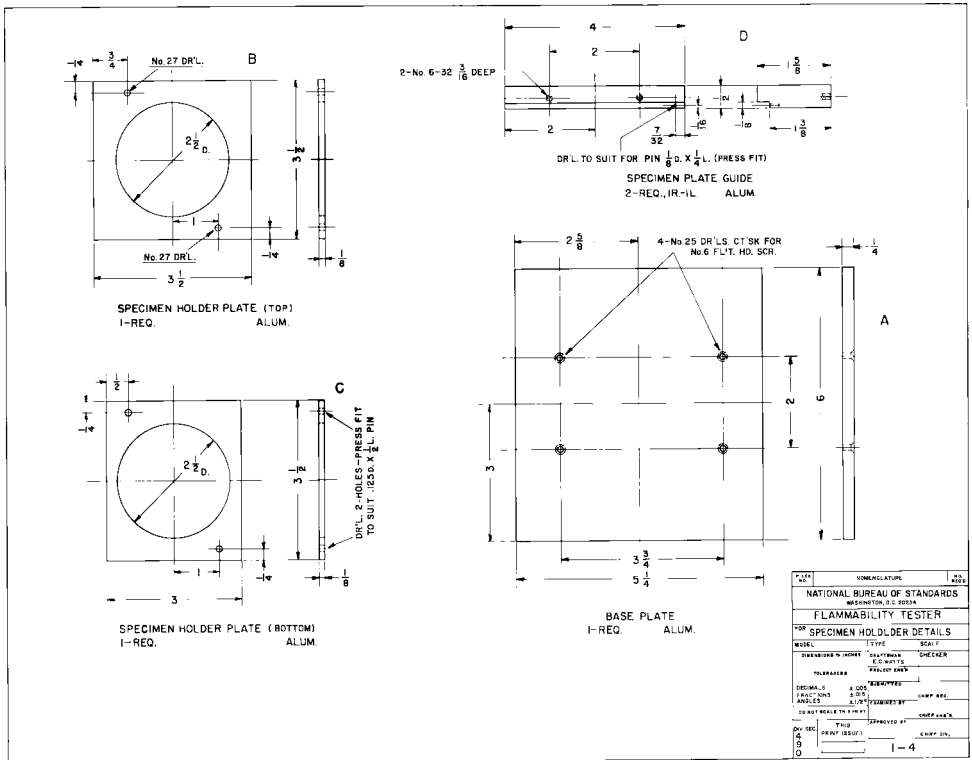

FIG. 6 Specimen Holder Details

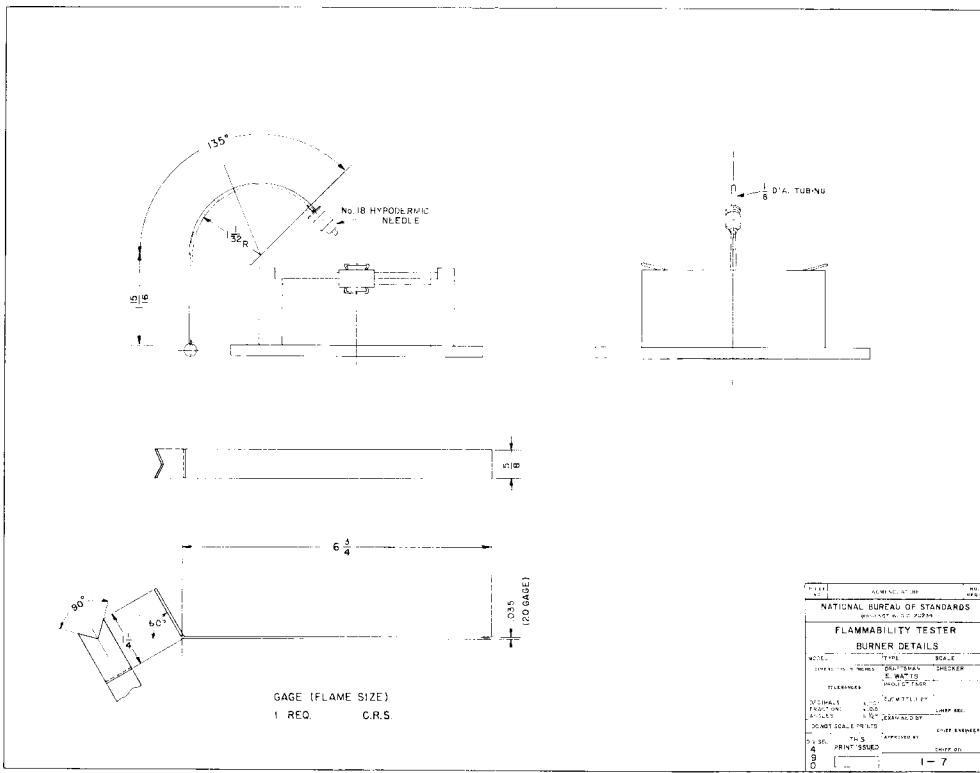

FIG. 7 Burner Details

6.6 Laboratory Drying Oven, forced-draft.

6.8 Silica Gel Desiccant, indicating type.

6.7 Desiccator(s) of sufficient size to hold five mounted specimens at one time.

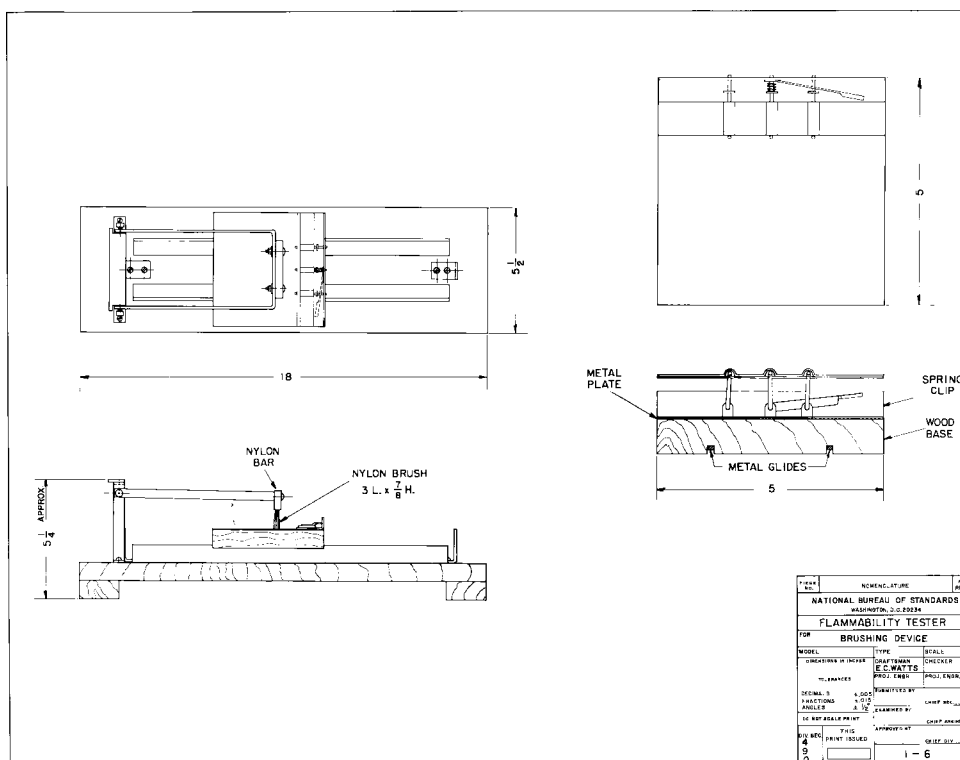

FIG. 8 Brushing Device

6.9 *Paper Monitor*,⁵ conforming to Federal Specification NNN-P-40b, Type II.

6.10 *Laboratory Hood*, or other suitable enclosure, to provide a draft free environment surrounding the flammability tester.

7. Sampling

7.1 *Lot Size*—A lot is defined as all the fabric in a single manufacturing run of one type of fabric not exceeding 100 rolls or pieces or 4000 end-use items.

7.2 *Lot Sample*—Unless otherwise agreed upon, as when specified in an applicable material specification, randomly take as the lot sample the number of rolls, pieces, or end-use items specified in Table 1.

TABLE 1 Selection of Lot Samples of Blanket Fabric

Number of Units in Lot		Rolls, Pieces, End-Use Items in Sample	Number Specimens
Rolls or Pieces	End-Use Items		
1 to 10	1 to 400	1	10
11 to 20	401 to 800	2	20
21 to 30	801 to 1200	3	30
31 to 40	1201 to 1600	4	40
41 or more	1601 or more	5	50

7.3 *Laboratory Sample*—For fabric in rolls or pieces, take as a laboratory sample a full width swatch 1 m (1 yd) long from

the outside of each roll in the lot sample or from one end of each piece in the lot sample, after first discarding a full width length of 1 m from the very end of each roll or piece. For fabric already made up into end-use items, such as blankets, all of the items in the lot sample will constitute the laboratory sample.

7.4 *Conditions for Sampling*—Sample and test the finished fabric as it will reach the consumer. Remove the wire harness from electric blankets before testing.

7.5 *Test Specimens*—Test specimens are to be taken from each unit of the laboratory sample as described in 8.1.

8. Preparation of Specimens and Paper Monitor

8.1 *Cutting Specimens*—Ten specimens, each measuring 70 by 70 mm (2.75 by 2.75 in.), shall be randomly selected from each swatch or end-use item in the laboratory sample. No specimen shall be taken nearer to the selvages or fabric edges than 1/10 of the width of the sample.

8.1.1 Carefully note the face or back side of the fabric.

8.2 *Cutting Paper Monitor*—Ten paper monitors, each measuring 75 by 90 mm (3.0 by 3.5 in.) with hole punches as shown in Fig. 4, except that the large center hole shall be 50 mm (2 in.) in diameter instead of 65 mm (2.5 in.) as cut in the specimen holder plate.

8.3 *Brushing*—Each specimen having a raised fiber surface shall be brushed once against the lay of the surface fibers with the brushing device shown in Fig. 8. Other specimens do not require brushing.

8.4 *Specimen Mounting*—After brushing, mount each specimen in a specimen holder. Avoid handling the specimens except on the edges. Mount the specimen and paper monitor in the following order: (1) bottom plate, (2) specimen with

⁵ Paper conforming to Fed. Spec. NNN-P-40b, Type II, as lens paper may be purchased as Catalog No. 52845-009, sold by VWR Scientific Products, 1430 Waukegan Road, McGraw Park, IL 60085-6787.

surface to be tested facing upward, (3) paper monitor, placed with the two small holes fitting over the guide pins on the bottom plate of the specimen holder and (4) top plate. This should set the larger circular hole in the paper concentric with the hole in the top plate.

9. Preparation of Apparatus

9.1 Burner Adjustment:

9.1.1 Adjust the burner in the actuated position (see Fig. 9) so the burner tip is 8 mm ($\frac{5}{16}$ in.) from the specimen surface. A burner height gage clamped in the specimen holder, Fig. 7, may be used for this adjustment. With the burner in the actuated position, move the base and holder assembly away from the burner tube so that the burner tip is 3.2 mm ($\frac{1}{8}$ in.) off center. Secure holder assembly to cabinet floor.

9.1.2 Adjust the timer so that the burner, when actuated, remains in position. Apply the flame to the specimen for an average time of 1 ± 0.05 s. This is accomplished by actuating the burner mechanism, reading the time on the counter, and adjusting as necessary.

9.1.3 Adjust the flame length with the hood fan turned off and the burner in the retracted position. Use the needle valve to adjust the flame length to 16 mm ($\frac{5}{8}$ in.) from the tip of the burner, measuring only the clearly visible yellow portion of the flame. A suitable gage for this adjustment is shown in Fig. 7. The gage is held at a right angle to the burner axis. It is necessary to allow gas to flow through the burner for up to 5 min to purge all air from the system before attempting to adjust the flame length.

10. Conditioning

10.1 Dry the mounted specimens in a horizontal position in a forced draft oven at $105 \pm 3^\circ\text{C}$ ($220 \pm 5^\circ\text{F}$) for 30 min, remove from the oven, and place over an indicating desiccant such as silica gel for not less than 30 min nor more than 60 min.

10.1.1 Ensure that the brushed surface of each specimen is not touched or disturbed.

10.1.2 Do not place more than five specimens in the desiccator at one time.

11. Procedure

11.1 After preparing the apparatus, remove a mounted specimen from the desiccator and place it in position on the rack in the chamber of the apparatus. Expose the specimen to the flame within 30 s of the time it is removed from the desiccator.

11.2 Close the door of the apparatus. Set the timer at zero. Conduct the test in a draft-free room with the apparatus at room temperature.

11.3 Activate the timing mechanism to apply the flame to the specimen for a period of 1 ± 0.05 s.

11.4 When the burner combustion has stopped, as evidenced by the absence of flame and afterglow, remove the mounted specimen from the cabinet, place it on a flat surface, and determine whether or not ignition has occurred.

11.4.1 Ignition is considered to have occurred if the paper monitor is burned, charred, or discolored at any point.

11.5 Test ten specimens, five on the face side and five on the back side for each laboratory sample unit.

12. Interpretation of Results

12.1 In order to place blanket fabrics in one or another of two classes of flammability, a decision is made on whether or not a paper monitor burns, chars, or discolors as described in 11.4.1. It must be understood, however, that no guarantee can be given and none is implied that a blanket fabric or product falling into either of the two classes will or will not be hazardous under some conditions of use.

12.2 The classes are as follows:

12.2.1 *Class I*—If none of the paper monitors burn, char, or become discolored after exposing the specimens to the ignition source, the material is classified as Class I. Class I textiles are generally considered by the trade as having nonunusual burning characteristics and are acceptable for use in manufacturing blankets.

12.2.2 *Class II*—If one or more of the paper monitors burn, char, or become discolored after exposing the specimens to the ignition source, the material is classified as Class II. Class II textiles are considered to be sufficiently flammable that they

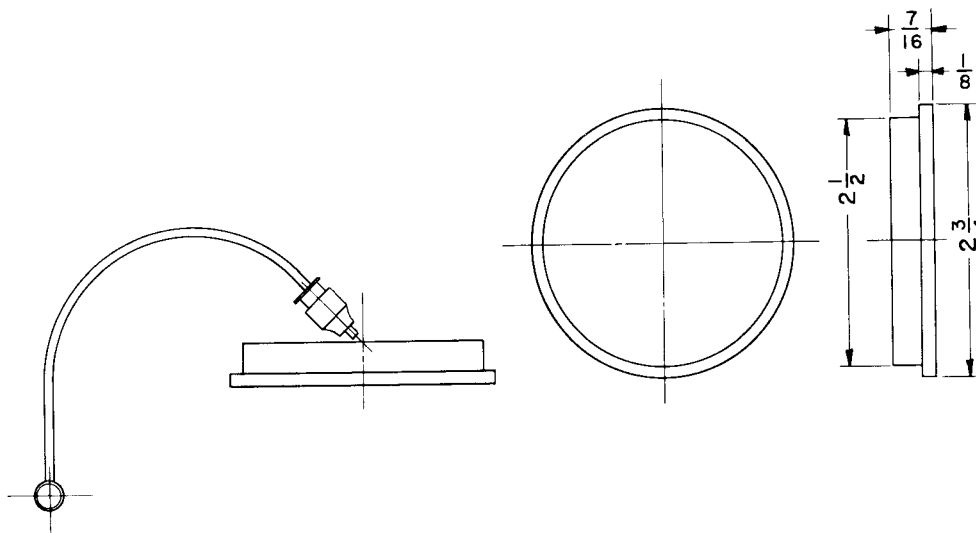

FIG. 9 Setting Burner Position

are recognized by the trade as being unsuitable for blanket manufacture.

13. Report

13.1 State that the specimens were tested as directed in ASTM Test Method D 4151. Describe the material or product sampled, the method of sampling used, and its lot size.

13.2 Report the following information:

13.2.1 Number of ignitions causing the paper monitor to burn, char, or discolor.

13.2.2 Classification of each specimen.

13.2.3 Classification of each lot.

14. Precision and Bias

14.1 No justifiable statements can be made either on the precision or on the bias of Test Method D 4151 for measuring the flammability of blankets since the test result merely states whether there is conformance to the criteria for success specified in the procedure.

15. Keywords

15.1 blanket; flammability

The American Society for Testing and Materials takes no position respecting the validity of any patent rights asserted in connection with any item mentioned in this standard. Users of this standard are expressly advised that determination of the validity of any such patent rights, and the risk of infringement of such rights, are entirely their own responsibility.

This standard is subject to revision at any time by the responsible technical committee and must be reviewed every five years and if not revised, either reapproved or withdrawn. Your comments are invited either for revision of this standard or for additional standards and should be addressed to ASTM Headquarters. Your comments will receive careful consideration at a meeting of the responsible technical committee, which you may attend. If you feel that your comments have not received a fair hearing you should make your views known to the ASTM Committee on Standards, at the address shown below.

This standard is copyrighted by ASTM, 100 Barr Harbor Drive, PO Box C700, West Conshohocken, PA 19428-2959, United States. Individual reprints (single or multiple copies) of this standard may be obtained by contacting ASTM at the above address or at 610-832-9585 (phone), 610-832-9555 (fax), or service@astm.org (e-mail); or through the ASTM website (www.astm.org).