



Designation: D 4772 – 97

Standard Test Method for Surface Water Absorption of Terry Fabrics (Water Flow)¹

This standard is issued under the fixed designation D 4772; the number immediately following the designation indicates the year of original adoption or, in the case of revision, the year of last revision. A number in parentheses indicates the year of last reappraisal. A superscript epsilon (ϵ) indicates an editorial change since the last revision or reappraisal.

1. Scope

1.1 This test method determines the ability of a terry fabric to rapidly absorb and retain liquid water from surfaces such as human skin, dishes, and furniture.

1.2 This test method is not applicable to non-terry fabrics such as huck towels, waffle-weave towels, crash towels, flour-sack towels, and nonwoven wipes. The steep angle of the specimen on the apparatus may cause a large amount of water to runoff these non-pile fabrics, or the lightweight/open structure of these fabrics may allow a large amount of water to completely pass through the specimen; thus the test result may not be a valid measure of a non-terry fabric's ability to absorb water.

1.3 This test method is not applicable to decorative terry fabrics that will not be used to absorb water from surfaces.

1.4 This test method is written in SI units. The inch-pound units that are provided are not necessarily exact equivalents of the SI units. Either system of units may be used in this test method. In case of referee decisions the SI units will prevail.

1.5 *This standard does not purport to address all of the safety concerns, if any, associated with its use. It is the responsibility of the user of this standard to establish appropriate safety and health practices and determine the applicability of regulatory limitations prior to use.*

2. Referenced Documents

2.1 ASTM Standards:

D 123 Terminology Relating to Textiles²

D 1776 Practice for Conditioning Textiles for Testing²

D 2904 Practice for Interlaboratory Testing of a Textile Test Method that Produces Normally Distributed Data²

D 2906 Practice for Statements on Precision and Bias for Textiles²

D 3136 Terminology for Permanent Care Labels for Con-

sumer Textile and Leather Products Other Than Carpets and Upholstery²

D 5433 Performance Specification for Towel Products for Institutional and Household Use³

2.2 AATCC Standard:

Test Method 135 Dimensional Changes in Automatic Home Laundering of Woven and Knit Fabrics⁴

3. Terminology

3.1 Definitions:

3.1.1 *absorption, n*—a process in which one material (the absorbent) takes in or absorbs another (the absorbate); as the absorption of moisture by fibers.

3.1.2 *pile, n—in pile fabric*, the raised loops or tufts (cut loops) that form all or part of the surface.

3.1.3 *surface water absorption, n—by a fabric*, the process of removing liquid water from a surface such as human skin, dishes, or furniture.

3.1.4 *terry fabric, n*—a material with a woven warp pile or a knitted pile, with uncut loops on a single side or uncut loops on both sides, and which is used for such products as toweling, beachwear, and bathrobes.

3.1.5 For definitions of other textile terms used in this test method, refer to Terminologies D 123 and D 3136.

4. Summary of Test Method

4.1 A terry fabric product with hems or with both hems and selvages (such as a bath towel), or a terry fabric without hems or without both hems and selvages (such as a terry fabric cut from a roll) is prepared for testing by preconditioning and conditioning. Specimens are placed one at a time in an embroidery hoop and then the hoop/specimen assembly is placed at an angle on the base of the apparatus. After water flows down the surface of each specimen, the amount of water retained by each specimen is measured. Six specimens are tested, three on the face of the fabric and three on the back of the fabric. The six observations are averaged to determine the surface water absorption of the fabric.

¹ This test method is under the jurisdiction of ASTM Committee D-13 on Textiles and is the direct responsibility of Subcommittee D13.59 on Fabric Test Methods, General.

Current edition approved Jan. 10, 1997. Published June 1997. Originally published as D 4772-88. Last previous edition D 4772-88.

² *Annual Book of ASTM Standards*, Vol 07.01.

³ *Annual Book of ASTM Standards*, Vol 07.02.

⁴ Available from American Association of Textile Chemists and Colorists, P.O. Box 12215, Research Triangle Park, NC 27709.

5. Significance and Use

5.1 This test method may be used to test the surface water absorption of terry fabrics for bath towels, bath sheets, hand towels, kitchen towels, dishcloths, washcloths, beachwear, bathrobes, and the like. Different specifications may be needed for each of these fabrics because of different applications.⁵

5.2 It is recognized that surface water absorption is only one of the characteristics that the ultimate consumer may use in determining which terry fabric is acceptable. Consult Specification D 5433 for other characteristics that may be applicable to terry fabrics.

5.3 This test method is recommended for quality control testing of terry fabrics during manufacturing and product comparisons of different terry fabrics by manufacturers, retailers, and users.

5.4 This test method may be used for the acceptance testing of commercial shipments of terry fabrics, but caution is advised since interlaboratory precision is known to be poor. Comparative tests as directed in 5.4.1 may be advisable.

5.4.1 In case of a dispute arising from differences in reported test results when using this test method for acceptance testing of commercial shipments, the purchaser and the supplier should conduct comparative tests to determine if there is a statistical bias between their laboratories. Competent statistical assistance is recommended for the investigation of bias. As a minimum, the two parties should take a group of laboratory sampling units (such as towels) that are as homogeneous as possible and that are from a lot of material of the type in question. The laboratory sampling units should then be randomly assigned in equal numbers to each laboratory for testing. The average results from the two laboratories should be compared using appropriate statistical analysis for unpaired data and an acceptable probability level chosen by the two parties before the testing is begun. If a bias is found, either its cause must be found and corrected or the purchaser and supplier must agree to interpret future test results with consideration of the known bias.

6. Apparatus and Materials

6.1 *Water Flow Tester*—This tester is not commercially available, but it is not difficult or expensive to build. The tester shown in Figs. 1-3 can be made from the parts and the series of steps described in Annex A1; however, there are other acceptable ways to build the tester. Sections 6.1.1-6.1.4 indicate the critical factors which must be incorporated into the design of the tester.

6.1.1 The hoop/specimen assembly must be at 1.1 rad (60°) to the table top (see Fig. 1 and Fig. 3).

6.1.2 The 50-mL graduate mounted on the apparatus must be parallel to the table top (see Figs. 1 and 2). The pour spout on this graduate must be 3.0 ± 0.2 cm (1.18 ± 0.08 in.) down from where the adjustment screw bracket joints the outer hoop

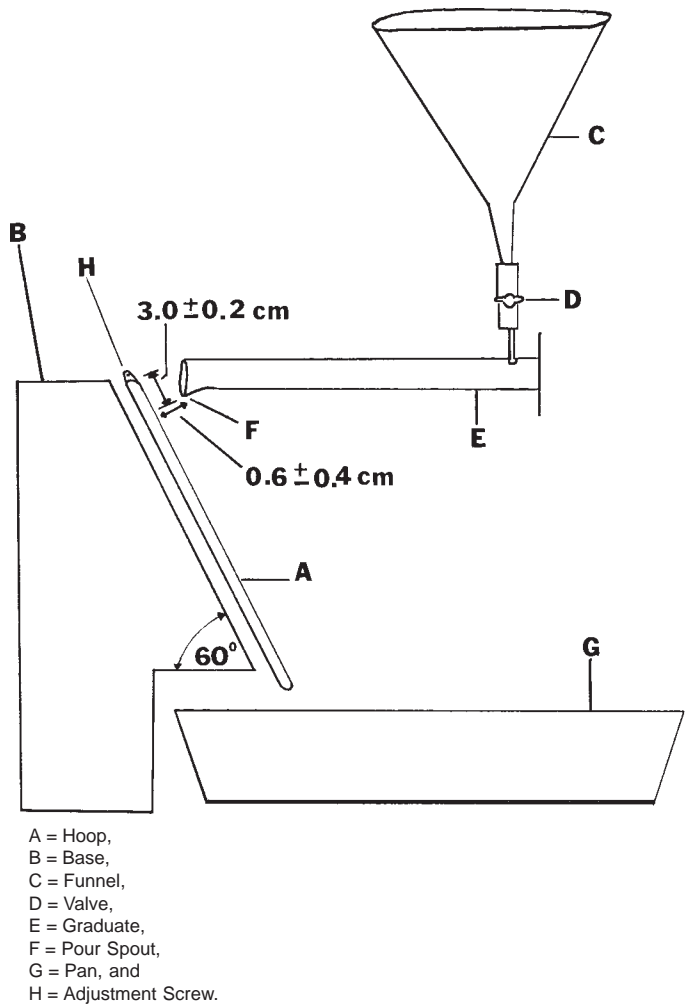

FIG. 1 Schematic Diagram of a Typical Water Flow Tester

and 0.6 ± 0.4 cm (0.24 ± 0.16 in.) away from the hoop/specimen assembly (see Fig. 1 and Fig. 3).

6.1.3 The funnel, valve, fittings, tubing, and graduate mounted on the apparatus (see Fig. 2) must not restrict the flow of water. The time between the opening of the valve and the time the water has exited the graduate (except for a few drops) must be less than 8.0 s. (The tester shown in Figs. 2 and 3 has a mean of 5.7 s and a standard deviation of 0.5 s).

6.1.4 The hoop/specimen assembly must be mounted on the base in a manner to direct all water not absorbed by the specimen toward the pan (see Figs. 1-3). It is especially important that any water that passes completely through the specimen is directed toward the pan and is not allowed to be absorbed by the lower portion of the specimen, or the edge of the laboratory sampling unit, or held where the hoop contacts the base.

6.2 *Embroidery Hoop*, 15.3-cm (6-in.) outer diameter of inner hoop. If the hoop is made of wood, it must have a water-resistant finish (such as a marine varnish).

6.3 *Graduate, Polymethylpentene (PMP)* 50 mL.

6.4 *Distilled or Deionized Water*, at $21 \pm 1^\circ\text{C}$ ($70 \pm 2^\circ\text{F}$).

6.5 *Laboratory Sampling Unit Conditioning Equipment*, facilities such as a multiple shelf/rod conditioning rack (for

⁵ The relationship between water and textiles is complex. For information on the different forms of interaction between water and textiles see: Zeronian, S. H. "Analysis of the Interaction Between Water and Textiles," pages 117-128 in *Analytical Methods for a Textile Laboratory*, American Association of Textile Chemists and Colorists, third edition, 1984, edited by J. W. Weaver.



FIG. 2 A Typical Water Flow Tester

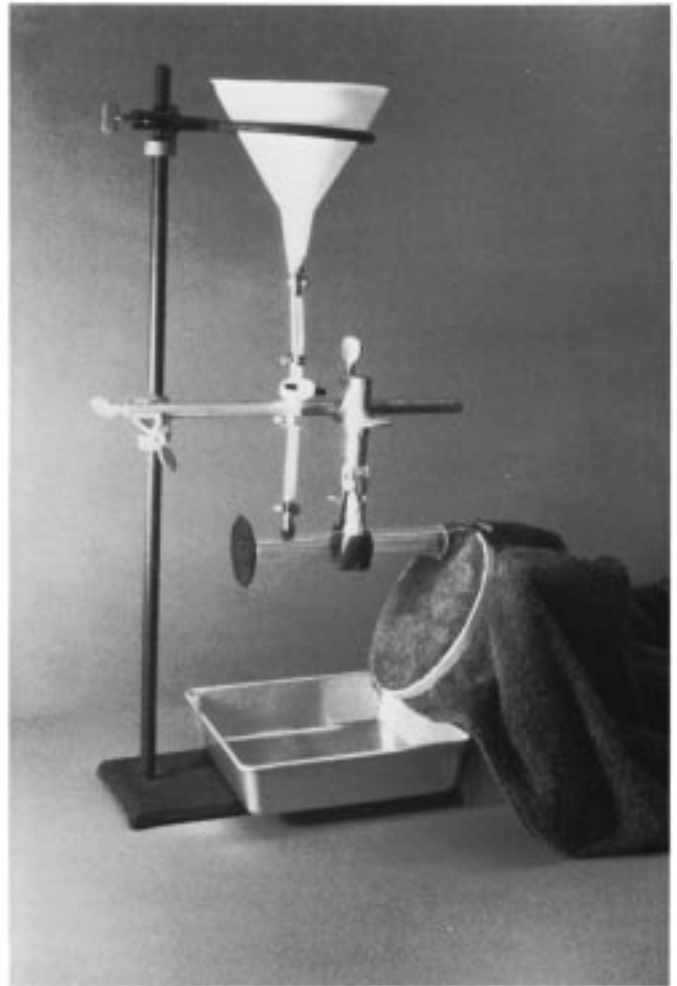

FIG. 3 The Water Flow Tester with the Laboratory Sampling Unit in Place

example see Practice D 1776) or a clothesline and clothespins. For more information see 9.2.

6.6 *Tumble Dryer*, equivalent to the one described in AATCC Test Method 135.

6.7 *Washing Machine*, equivalent to the one described in AATCC Test Method 135.

6.8 *Detergent*, heavy duty granule, equivalent to The 1993 AATCC Standard Reference Detergent described in AATCC Test Method 135 or any detergent agreed upon by the purchaser and the supplier that does not include fabric softener or bleach.

7. Sampling

7.1 *Lot Sample*—As a lot sample for acceptance testing, take at random the number of shipping cartons or the number of rolls of fabric directed in an applicable material specification or other agreement between the purchaser and the supplier. Consider shipping cartons or rolls of fabric to be the primary sampling units, see Note 1.

NOTE 1—Any agreement between the purchaser and supplier must take into account the variability between rolls, bolts, or pieces of fabric and between specimens from a swatch of fabric from a roll, bolt, or piece, or between cartons of garments and between garments within a carton, to

provide a sampling plan with a meaningful producer's risk, consumer's risk, acceptable quality level, and limiting quality level.

7.2 *Laboratory Sample*—As a laboratory sample for acceptance testing, take the number of laboratory sampling units specified in the agreement between the purchaser and the supplier. Take the laboratory sampling units as follows:

7.2.1 *Recommended Laboratory Sampling Unit*—Because this is a nondestructive test method, the recommended laboratory sampling unit is a terry fabric product with hems or with both hems and selvages (such as a bath towel). The fabric should be dyed and finished as the consumer would purchase it. A fabric approximately 112 (lengthwise direction) by 56 cm (44 by 22 in.) or larger is easier to test than a small fabric as all six observations can be made on one fabric, but the procedure allows for testing a small fabric such as a hand towel (see Note 2).

NOTE 2—A 20.0 by 20.0-cm (7.87 by 7.87-in.) fabric is the smallest laboratory sampling unit that can be tested on the apparatus. Six of these small laboratory sampling units will be needed to provide the six observations. In choosing the size of the laboratory sampling unit, keep in mind that terry fabric has a high degree of shrinkage during washing and drying.

7.2.2 *Alternate Laboratory Sampling Unit*—As an alternative to the procedure described in 7.2.1, a terry fabric without hems or without both hems and selvages can be used (such as a terry fabric cut from a roll). The fabric should be dyed and finished as the consumer would purchase it. A fabric approximately 112 (lengthwise direction) by 56 cm (44 by 22 in.) or larger is easier to test than a small fabric as all six observations can be made on one fabric, but the procedure allows for testing a small fabric (see Note 2).

7.3 *Specimens*—After the laboratory sampling unit(s) has been prepared as directed in Section 8 and conditioned as directed in Section 9, take six specimens (the area inside the hoop) by locating the hoop on the laboratory sampling unit(s) as follows:

7.3.1 For a laboratory sampling unit(s) that is approximately 112 (lengthwise direction) by 56 cm (44 by 22 in.) or larger, locate the hoop as shown in Fig. 4.

7.3.2 For a laboratory sampling unit(s) that is not large enough to locate the hoop so that all six specimens are on one laboratory sampling unit, alternate the hoop from face to back using as many laboratory sampling units as needed to obtain the six specimens.

8. Preparation of the Laboratory Sampling Unit

8.1 *Recommended Preparation of the Laboratory Sampling Unit*—The recommended preparation of the laboratory sampling unit uses a dryer to precondition the laboratory sampling unit and raise the pile so it is not matted down. See 6.6 for a description of the dryer. The procedure is as follows:

8.1.1 If fabric softener has recently been used in the dryer, dry a 3.6-kg (8-lb) dummy load of desized unsoftened fabrics which will not be tested, and then repeat this procedure with a different dummy load of 3.6 kg (8 lb) of desized unsoftened fabrics.⁶

8.1.2 Clean the lint filter.

8.1.3 Load the dryer with laboratory sampling units that comprise a homogeneous load (for example, same manufacturer, same line, same finishing, and same previous care). It is not necessary to have a full load in the dryer, so it is acceptable to load only one laboratory sampling unit into the dryer.

8.1.4 Select normal cycle, medium temperature (see Terminology D 3136, and AATCC Test Method 135), and run the dryer for 20 min. Do not use fabric softener during this procedure.

8.1.5 If the laboratory sampling unit(s) was originally damp, keep drying it for 10-min cycles until the fabric(s) is dry to the touch. Do not overdry the fabric(s).

8.2 *Alternate Preparation of the Laboratory Sampling Unit*—The alternate preparation of the laboratory sampling unit uses one cycle of washing and drying. This preconditions the laboratory sampling unit, raises the pile so it is not matted down, and removes some chemicals. Other numbers of washing and drying cycles, such as three or five, may be used. The

⁶ Dummy loads of fabrics may be comprised of desized unsoftened non-terry fabrics or terry fabrics.

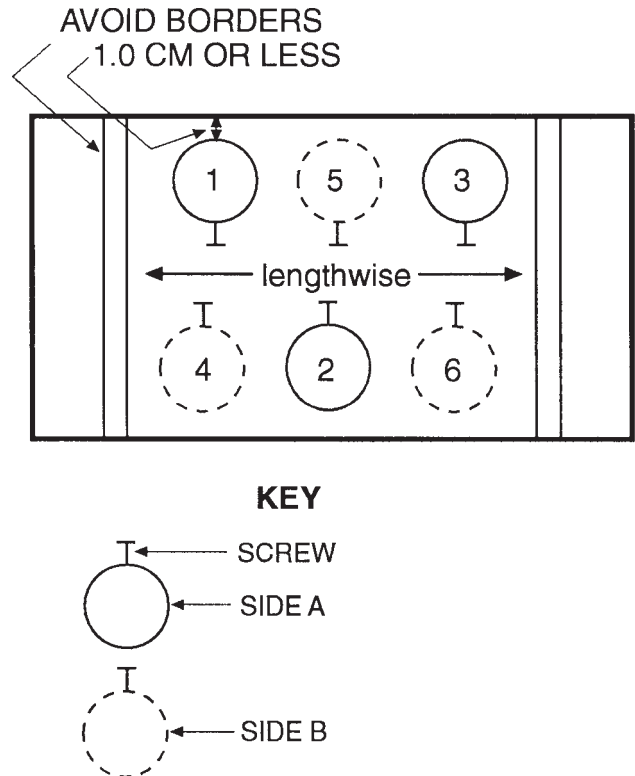

FIG. 4 Location of the Hoop for a Large Laboratory Sampling Unit Such as a Bath Towel

purchaser and the supplier, however, must agree on the number of washing and drying cycles. This procedure may cause more variation in the test result than the procedure described in 8.1 and it is not recommended for acceptance testing unless there has been an agreement between the purchaser and the supplier. This procedure uses the equipment and the supplies described in 6.6-6.8. The procedure is as follows:

8.2.1 If fabric softener has recently been used in the washer or dryer, wash or dry or both a 3.6-kg (8-lb) dummy load of desized unsoftened fabrics which will not be tested, and then repeat this procedure with a different dummy load of 3.6 kg (8 lb) of desized unsoftened fabrics.⁶

8.2.2 If the washer has a lint filter, clean the lint filter.

8.2.3 Load the washer with a 3.6-kg (8-lb) load of laboratory sampling units that comprise a homogeneous load (for example, same manufacturer, same line, same finishing, and same previous care) or a homogeneous group of laboratory sampling units for testing and a desized unsoftened group of dummy fabrics to make a 3.6-kg (8-lb) load.

8.2.4 Select normal cycle, warm water temperature, and The 1993 AATCC Standard Reference Detergent or equivalent detergent (see Terminology D 3136, and AATCC Test Method 135). If agreed upon by the purchaser and the supplier, other detergents and conditions are possible. Run one machine cycle and do not use softener.

8.2.5 Load the dryer with the washed fabrics. Clean the lint filter. Select normal cycle, medium temperature, and run the

dryer for 20 min or until the fabrics are dry to the touch. Do not use softener in the dryer. Do not overdry the fabrics.

9. Conditioning

9.1 Both preconditioning and conditioning are required. The dryer in 8.1 and 8.2 will precondition the laboratory sampling unit(s). Conditioning of the laboratory sampling unit(s) is described in 9.2.

9.2 Immediately after taking the laboratory sampling unit(s) out of the dryer, place it in the conditioning room. If the laboratory sampling unit(s) is to be cut to a smaller size agreed upon by the purchaser and the supplier (optional), the laboratory sampling unit(s) must be cut before conditioning. Remove lint from the laboratory sampling unit(s) by lightly brushing the surface with a clothes brush. During conditioning, hang the laboratory sampling unit(s) on a line or rod, or lay it flat on a shelf, or place it on a conditioning rack in a conditioning room so that at least one side is fully exposed to the standard atmosphere for testing textiles, which is $21 \pm 1^\circ\text{C}$ ($70 \pm 2^\circ\text{F}$) and $65 \pm 2\%$ relative humidity. At no time during conditioning should the laboratory sampling unit(s) be folded or stacked. About halfway through conditioning, turn over the laboratory sampling unit(s) so both sides will have had contact with the conditioned air. Allow the laboratory sampling unit(s) to condition for a minimum of 24 h and a maximum of 48 h before testing. The reason for the maximum time is terry fabric is able to pick up excess moisture from humid moving air and thus it can achieve a somewhat damp condition. If the maximum time has been exceeded, the procedure directed in 8.1 and Section 9 must be repeated.

10. Procedure

10.1 Test the conditioned laboratory sampling unit(s) in the standard atmosphere for testing textiles, which is $21 \pm 1^\circ\text{C}$ ($70 \pm 2^\circ\text{F}$) and $65 \pm 2\%$ relative humidity.

10.2 Place the apparatus (Figs. 1-3) on a flat surface where spilled water will not cause a problem.

10.3 With no laboratory sampling unit on the base, pre-wet the graduate attached to the apparatus by using the following procedure. While the valve is in a closed position, pour 50 ± 1 mL of distilled or deionized water at $21 \pm 1^\circ\text{C}$ ($70 \pm 2^\circ\text{F}$) in the graduate which is not attached to the apparatus and then pour this water into the funnel. Open the valve and allow the water to run through the apparatus and into the pan. Thoroughly dry the base, the hoop, and the pan.

10.4 Place the hoop on the laboratory sampling unit so that no more than 1.0 cm (0.39 in.) of the laboratory sampling unit extends past the bottom of the hoop (see Figs. 3 and 4). Do not include borders, hems, stitches, or selvages in the area of the specimen (the area inside the hoop). Position the adjustment screw on the hoop so it will later be in an upward position and it will be visible to the operator (see Figs. 3 and 4). In other words, when the hoop/specimen assembly is later placed on the base and the operator looks at the area of the specimen inside the hoop, an imaginary line that represents the lengthwise (warp or wale) direction of the specimen will be parallel to the table top. Position the specimen in relation to the hoop so that the lengthwise direction of the specimen will be parallel to the table top when the test is conducted (see Figs. 3 and 4). Adjust

the adjustment screw to securely hold the fabric in place while being neither tight enough to distort the fabric nor loose enough that the fabric sags. Position the outer ring of the hoop so it is not higher than the specimen and thus it does not trap water between it and the specimen.

10.5 Mount the hoop/specimen assembly on the base. Excess laboratory sampling unit must be allowed to drape over the sides and the back of the base (see Fig. 3).

10.6 Position the hoop/specimen assembly (see Figs. 1 and 3) so that the bottom of the pour spout is 0.6 ± 0.4 cm (0.24 ± 0.16 in.) away from the specimen, 3.0 ± 0.2 cm (1.18 ± 0.08 in.) down from where the adjustment screw bracket joins the outer hoop, and centered between the sides of the hoop.

10.7 Push the pan against the base so all the water will go into the pan.

10.8 While the valve is in a closed position, pour 50 ± 1 mL of distilled or deionized water at $21 \pm 1^\circ\text{C}$ ($70 \pm 2^\circ\text{F}$) into the graduate which is not attached to the apparatus and then pour this water into the funnel. Open the valve and allow the water to run down the surface of the specimen held in the hoop. Collect the water in the pan. Allow 25 ± 5 s to elapse between the time the water stops coming out of the graduate attached to the apparatus and the removal of the pan. Do not tap on or tilt the graduate attached to the apparatus to try to get all the drops of water out.

10.9 Pour the runoff water, which is now in the pan, into the 50-mL graduate not attached to the apparatus and record the number of millilitres of runoff water to the nearest 1.0 mL. Subtract the number of millilitres of runoff water from 50 and record this value as the observation. Also record the side of the laboratory sampling unit on which this observation was taken. Discard the water now in the graduate not attached to the apparatus. Do not reuse this water.

10.10 Remove the laboratory sampling unit from the hoop. Do not allow the tested wet area(s) of the laboratory sampling unit to contact untested dry area(s). Thoroughly dry the hoop, the base, and the pan. If any water has missed the pan and is now on the surface below the apparatus, this observation is not valid and the procedure will have to be repeated on a dry area of the laboratory sampling unit or a new laboratory sampling unit.

10.11 Repeat procedures 10.4-10.10 for all specimens of the laboratory sampling unit(s); three face specimens (side A) and three back specimens (side B) are needed (see Fig. 4 for the order of testing). Specimens (the area inside the hoop) must be 6.0 cm (2.36 in.) or more apart to avoid wicking from one specimen to another. If one laboratory sampling unit is not of sufficient size to obtain all six specimens, alternate face and back specimens on as many laboratory sampling units as needed to obtain the six observations.

10.12 If testing is interrupted for more than 30 min, repeat procedure 10.3 to re-wet the apparatus.

11. Calculation

11.1 Calculate the average absorption of side A (face) to the nearest 1.0 mL by averaging the observations taken on side A of the laboratory sampling unit(s) (see Note 3).

NOTE 3—If small or multiple laboratory sampling units (such as hand towels) are being tested, it may not be possible to identify a corresponding side A or side B for all of the laboratory sampling units. In that case, do not calculate the absorption of side A and side B.

11.2 Calculate the average absorption of side B (back) to the nearest 1.0 mL by averaging the observations taken on side B (see Note 3).

11.3 Calculate the overall absorption of the laboratory sampling unit(s) to the nearest 1.0 mL by averaging all of the observations taken on the laboratory sampling unit(s).

12. Report

12.1 State that the specimens were tested as directed in Test Method D 4772. Describe the material or product being sampled and the method of sampling used.

12.2 Report the following information:

12.2.1 The number of observations from each laboratory sampling unit.

12.2.2 The number of laboratory sampling units used to obtain the overall absorption.

12.2.3 The size of each laboratory sampling unit.

12.2.4 The method of preparation of each laboratory sampling unit.

12.2.5 The average absorption of side A (face).

12.2.6 The average absorption of side B (back).

12.2.7 The overall absorption of the laboratory sampling unit(s).

13. Precision and Bias

13.1 *Summary*—The terminology and procedures in Practices D 2904 and D 2906 were used to determine the precision and bias of this test method and to write this statement. For this test method, the test result is an average of six observations of the water absorbed by a terry fabric. In comparing two averages from this test method, the difference should not exceed 2.3 mL in 95 cases out of 100 when all of the observations are taken by the same well-trained operator using the same piece of test equipment and specimens drawn randomly from the same sample of material and tested on the same day. The size of the difference is likely to be affected adversely by different circumstances. The true value of the water absorbed by terry fabric can be defined only in terms of a specific test method. Within this limitation, the procedure in

this test method has no known bias. Sections 13.2-13.4 explain the basis for this summary and for evaluations made under other conditions.

13.2 *Interlaboratory Test Data*⁷—An interlaboratory test was run in 1982 in which randomly drawn samples of nine materials were tested in each of five laboratories. Each laboratory had one operator who tested six specimens of each material. The nine materials were terry towels supplied by three producers. The components of variance expressed as standard deviations were calculated to be the values listed in Table 1 (see Note 4).

NOTE 4—The square roots of the components of variance are being reported to express the variability in the appropriate units of measure rather than as the squares of those units of measure.

13.3 *Critical Differences*—For the components of variance listed in Table 1, two averages of observed values should be considered significantly different at the 95 % probability level if the difference equals or exceeds the critical differences listed in Table 2 (see Note 5).

NOTE 5—The tabulated values of the critical differences should be considered to be a general statement, particularly with regard to interlaboratory precision. Before a meaningful statement can be made about two specific laboratories, the amount of statistical bias, if any, between them must be established, with each comparison being based on recent data obtained on specimens from a lot of material of the type being evaluated so as to be as nearly homogeneous as possible, and then randomly assigned in equal numbers to each of the laboratories.

13.4 *Bias*—The procedure in this test method for measuring the water absorbed by terry fabric has no bias because the value of this property can be defined only in terms of a test method.

14. Keywords

14.1 absorption; surface water absorption; terry fabric; toweling; water

⁷ Supporting data is available from ASTM Headquarters. Request RR: D-13-1083.

TABLE 1 Components of Variance as Standard Deviations (Units are mL of Water Absorbed by Fabric)

	Single-Operator Component	Interlaboratory Component
Single-material comparisons	2.0	1.4
Multimaterial comparisons	2.0	2.0

TABLE 2 Critical Differences for the Conditions Noted, 95 % Probability Level (Units are mL of Water Absorbed by Fabric)^A

	Number of Observations in Each Average	Single-Operator Precision	Interlaboratory Precision
Single-material comparisons	1	5.5	6.8
	3	3.2	5.0
	6	2.3	4.5
	9	1.9	4.3
Multimaterial comparisons	1	5.5	7.8
	3	3.2	6.4
	6	2.3	6.0
	9	1.9	5.8

^A The critical differences were calculated using $z = 1.960$.

ANNEX

(Mandatory Information)

A1. CONSTRUCTION OF THE WATER FLOW TESTER

A1.1 Introduction

A1.1.1 This annex describes the parts needed to construct the water flow tester and the sequence of steps for assembly of the tester.

A1.1.2 Most of the parts are standard laboratory equipment. Changes in the assembly of the tester and the substitution of parts may be made so long as the critical factors listed in 6.1 of the test method are incorporated into the design of the tester.

A1.2 Parts of the Water Flow Tester

A1.2.1 *Two Sets of Embroidery Hoops* (one set is a spare), made of wood, plastic, or metal. If the hoops are made of wood, they must be treated with a water-resistant finish (see A1.2.21 and A1.3.11). The outer diameter of the inner hoop is 15.3 cm (6 in.).⁸

A1.2.2 *Pan*, for catching the water that flows off or goes through the specimen (see Fig. A1.1). The size of the pan is not critical, but it must fit under the 1.1 rad (60°) face of the base so all the water not absorbed by the specimen goes into the pan. The size of the aluminum pan shown in Fig. A1.1 is 20.3 (length) by 20.3 (width) by 5.1 (height) cm (8 by 8 by 2 in.).⁹

A1.2.3 *Ring Stand Base*, as shown in Fig. 2 of the test method, has a 1.3 cm (0.5 in.) hole for the vertical rod (see A1.2.4). The dimensions of this base are 22.0 (length) by 13.3 (width) by 1.6 (height) cm (8.7 by 5.24 by 0.63 in.).¹⁰

A1.2.4 *Vertical Rod*, as shown in Fig. 2 of the test method, is 61.0 by 1.3 cm (24 by 0.5 in.).¹⁰

A1.2.5 *Two Collars*, each with a 1.3-cm (0.5-in.) inner diameter and a set screw, on the vertical rod provide extra

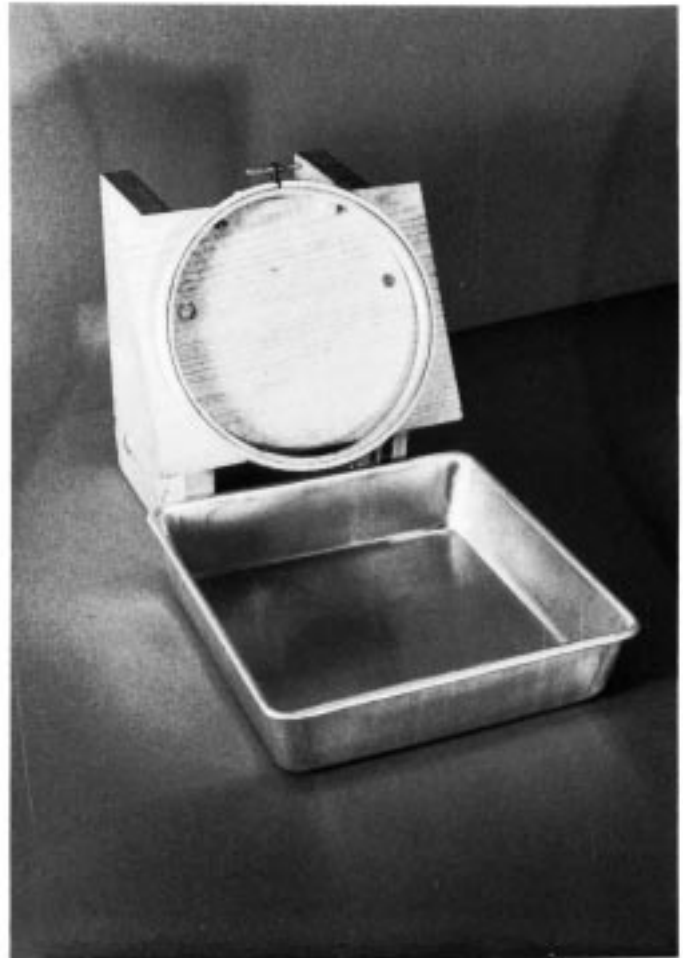

NOTE 1—There is a gap for water drainage between the hoop and the face of the base.

FIG. A1.1 The Base, Hoop, and Pan

⁸ These hoops can be purchased at fabric and discount stores.

⁹ This pan can be purchased where baking pans are sold.

¹⁰ Laboratory supplies can be obtained from a scientific company such as Fisher Scientific, 711 Forbes Avenue, Pittsburgh, PA 15219.

support for the clamp holder (see A1.2.6) and the cast-iron ring with integral clamp (see A1.2.9).¹¹

A1.2.6 *Clamp Holder*, to hold the horizontal rod (see A1.2.7) to the vertical rod.¹⁰

A1.2.7 *Horizontal Rod*, which holds the combination utility clamp (see A1.2.8) and the graduate (see A1.2.15), is 30.5 by 1.3 cm (12 by 0.5 in.). This length was obtained by cutting a 61-cm (24-in.) rod with a hacksaw.¹⁰

A1.2.8 *Combination Utility and “Burette” Clamp*, to hold the graduate to the horizontal rod. The clamp is 16.5-cm (6.5-in.) long and has a “flat jaw” with neoprene sleeves.¹⁰

A1.2.9 *Cast-Iron Ring with Integral Clamp*, to hold the funnel (see A1.2.10) to the vertical rod (see A1.2.4). The center of the ring is 11.0 cm (4.3 in.) from the center of the clamp. The inside diameter of the ring is 11.0 cm (4.3 in.).¹⁰

A1.2.10 *Funnel (Polypropylene)*, with a top diameter of 14.0 cm (5.5 in.), 14.6-cm (5.75-in.) length, and a stem inner diameter of 0.95 cm ($\frac{3}{8}$ in.) at the smallest part of the taper. The only critical dimension of the funnel is the inner diameter of the stem, as the hose connector fitting (see A1.2.11) must have a tight fit. Because the stem is tapered, the stem can be cut with a hacksaw to provide the proper fit.^{10,11}

A1.2.11 *Two-Hose Connector Fittings*, brass or plastic fittings to connect the tubing to the funnel and the graduate. On the tubing side of the fitting, the end is for 0.64-cm (0.25-in.) inner diameter tubing. On the other side of the fitting is a threaded male connector which is 0.95 cm ($\frac{3}{8}$ in.). The bore should be large enough to allow a 0.36 cm ($\frac{9}{64}$ in.) drill bit to pass through the center.¹¹

A1.2.12 *Tubing*, made of clear plastic or rubber with an inner diameter of 0.64 cm (0.25 in.). A length of about 30.5 cm (12.0 in.) is needed.^{10,11}

A1.2.13 *Four Tubing Clamps*, for the tubing described in A1.2.12.^{10,11}

A1.2.14 *Valve or Stopcock*, with two integral tapered hose ends for the tubing described in A1.2.12. The minimum bore is 0.4 cm (0.16 in.). The bore must be large enough to allow a 0.36-cm ($\frac{9}{64}$ in.) drill bit to pass through the center.¹⁰

A1.2.15 *Two Graduated Cylinders (Polymethylpentene 50 mL)*, with one graduate for the tester and one graduate for measuring the millilitres of water placed in the funnel and the millilitres of water not absorbed by the specimen.^{10,12}

A1.2.16 *Glue*, water resistant.¹¹

A1.2.17 *Pine Wood for the Base*, as shown in Fig. A1.2. This wood is called “6 by 1,” the actual size of the wood that was used to make the base was 61 (length) by 14.0 (width) by 1.9 (depth) cm (24 by 5.5 by 0.75 in.). Because the exact size of wood may vary, some changes may have to be made in the dimensions of the base. See A1.3.7.¹¹

A1.2.18 *Carriage Bolts, Washers, and Nuts*—Three carriage bolts, which are 15.24 (length) by 0.64 (diameter) cm (6.0 by 0.25 in.) number 20, nine washers 0.64 cm (0.25 in.), and nine nuts 0.64 cm (0.25 in.).¹¹

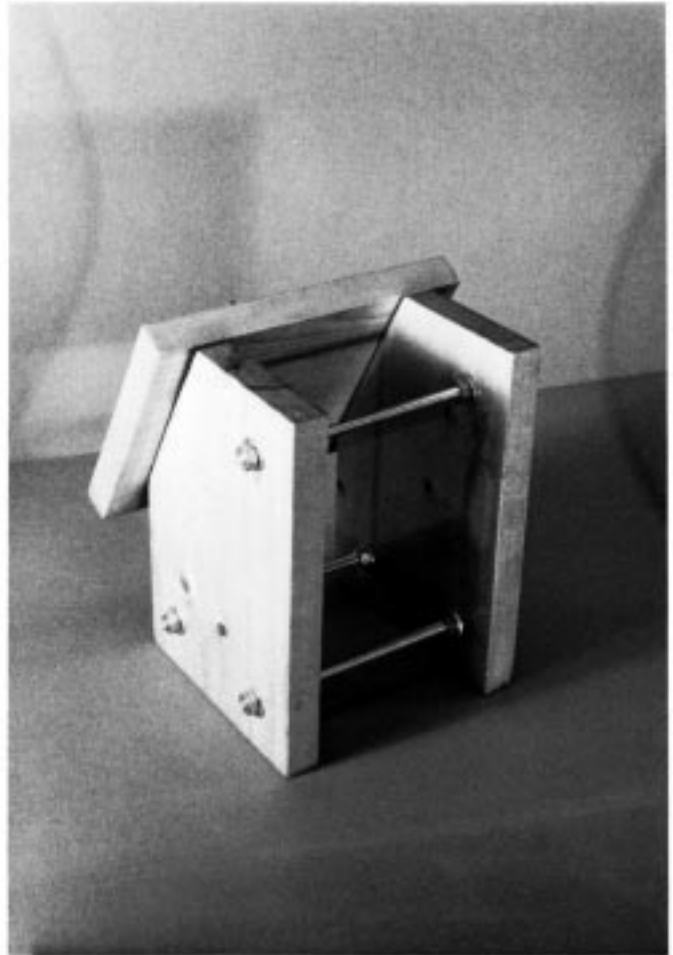

FIG. A1.2 Close-up of the Back Side of the Base

A1.2.19 *Two Round-Head Brass Wood Screws*, which are 1.6 (length) cm ($\frac{5}{8}$ in.) number 5. These screws support the hoop when it is placed on the face of the base.¹¹

A1.2.20 *Two Steel Flat-Head Wood Screws*, which are 3.2 cm (length) (1.25 in.) number 8. On the base these screws hold the face to the two sides.¹¹

A1.2.21 *Finish*, water resistant, for the wooden base and the wooden hoops if wooden hoops are used.^{11,13}

A1.3 Assembly of the Water Flow Tester

A1.3.1 As shown in Figs. 2 and 3 in the test method, and Fig. A1.3, assemble the ring stand, funnel support, and graduate support using the parts listed in A1.2.3-A1.2.9. The exact location of the clamps will be determined in a later step.

A1.3.2 For the graduate which will be attached to the apparatus, locate the hole for the fitting described in A1.2.11. The hole is on the opposite side of the graduate from the pour spout and is 4.0 cm (1.57 in.) from the base of the graduate (see Fig. A1.3). Using a progression of drill bits 0.28, 0.64, 0.79, and 0.95 cm ($\frac{7}{64}$, $\frac{1}{4}$, $\frac{5}{16}$, $\frac{3}{8}$ in.) and then a rat-tail file (if

¹¹ Plumbing and hardware supplies can be obtained from a large hardware store or plumbing supply.

¹² The brand of graduate used on the tester in Fig. 2, Fig. 3, and Fig. A1.3 was Nalgene (Nalgene part number 3663-0050).

¹³ The finish used on the base and hoops shown in the figures was Clear Super Valspar Gloss Varnish number 10.

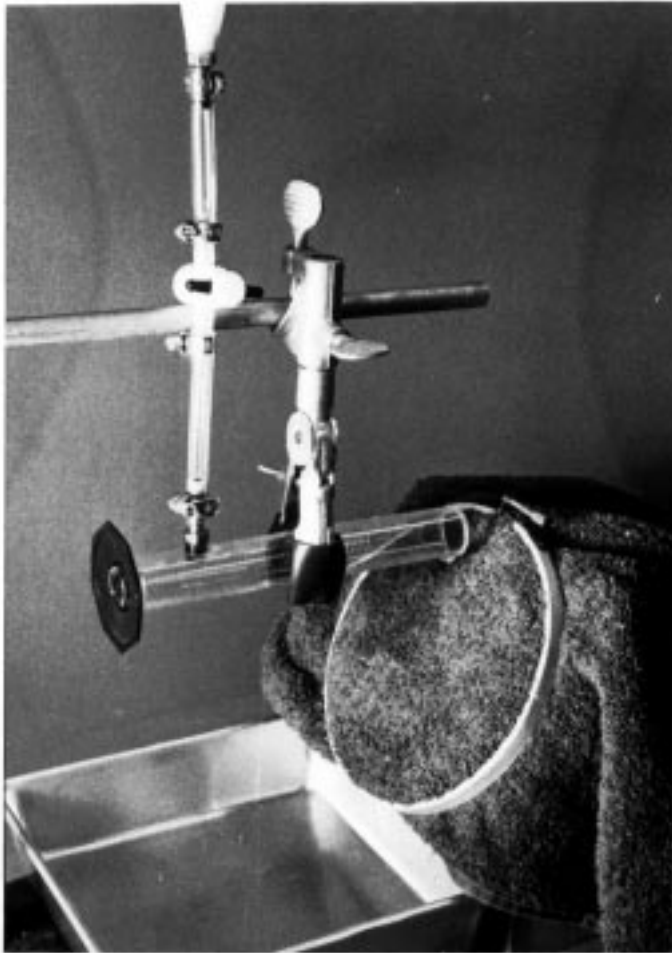

FIG. A1.3 Close-up of the Graduate Attached to the Tester

needed), make a hole in the graduate for the 0.95 cm ($\frac{3}{8}$ in.) end of the fitting. This fitting should not be forced in with a wrench, but keep trying to thread the fitting by turning it clockwise with your fingers. After the fitting will screw into the graduate, remove the fitting, clean the parts, and coat the hole in the graduate and the threaded part of the fitting with the glue. Then rescrew the fitting into the graduate and allow this assembly to dry.

A1.3.3 If the tapered stem of the funnel is too small, cut it with a hacksaw so the 0.95 cm ($\frac{3}{8}$ in.) end of the other fitting threads or slips into the tip of the stem. Coat the threaded part of the fitting and the inside of the stem with glue and reassemble the fitting and the funnel. Fill the tapered area between the inside of the stem of the funnel and the fitting with glue so that water put in the funnel at a later time will not be retained between the stem of the funnel and the fitting. Allow this assembly to dry.

A1.3.4 As shown in Fig. A1.3, place the graduate/fitting assembly in the “burette” clamp. Be sure the pour spout points downward.

A1.3.5 Using two tubing clamps and about 9.0 cm (3.5 in.) of tubing, attach the valve or stopcock to the tubing and then attach the tubing to the fitting on the graduate.

A1.3.6 Attach the other piece of tubing (about 21.6 cm or 8.5 in.) to the fitting on the funnel and then place the funnel in the cast iron ring attached to the ring stand. This tubing will be attached to the valve or stopcock in A1.3.16.

A1.3.7 With a saw, cut side A, side B, and the face of the base to the dimensions shown in Figs. A1.4 and A1.5. If the wood being used is less than 14.0-cm (5.5-in.) wide or the wood is wider and no adequate means of cutting the wood along its length is available, some adjustments will need to be made (draw a full-size drawing similar to Fig. A1.4 and then use a protractor, or a 1.1 rad (60°) angle drafting tool, or trigonometry, or subtract 14.0 from the actual width of the wood in centimetres and add the result to 8.3 to get the dimension that replaces 8.3 in Fig. A1.4) to obtain the correct dimensions so 1.1 rad (60°) is obtained. The critical factors are the face must be at 1.1 rad (60°) angle, the face must overhang the sides (see Fig. A1.5) by at least 3.0 cm (1.18 in.), and the bottom of the hoop must overhang the face (approximately a 0.5 cm or 0.2 in. air gap must exist between the inside of the hoop and the edge of the face) to allow the water that has passed through the specimen to get to the pan (see Fig. 2 in the test method, and Fig. A1.1).

A1.3.8 Drill the holes for the carriage bolts in sides A and B as shown in Fig. A1.4 (see symbol A).

A1.3.9 Drill the holes to attach the face to the sides as shown in Fig. A1.5 (see symbol B). The holes must be counter sunk so the head of the flat screw is below the upward plane of the face.

A1.3.10 As shown in Fig. A1.5, drill the pilot holes for the round-head wood screws that will retain the hoop at the proper location (see symbol C). Insert the screws so the heads are 0.8

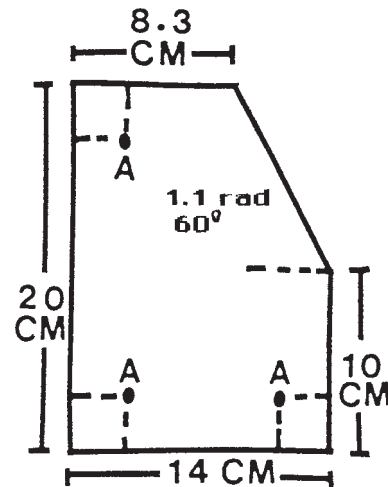

NOTE 1—A = 0.79 cm ($\frac{5}{16}$ in.) hole for the carriage bolt which is 3.0 cm (1.2 in.) away from the adjacent sides.

Inch Pound Equivalents			
cm	in.	cm	in.
1	0.4	10	3.9
3	1.2	14	5.5
3.5	1.4	18	7.0
5.5	2.1	20	7.8
8.3	3.2		

FIG. A1.4 Schematic Diagram for Both Sides of the Base

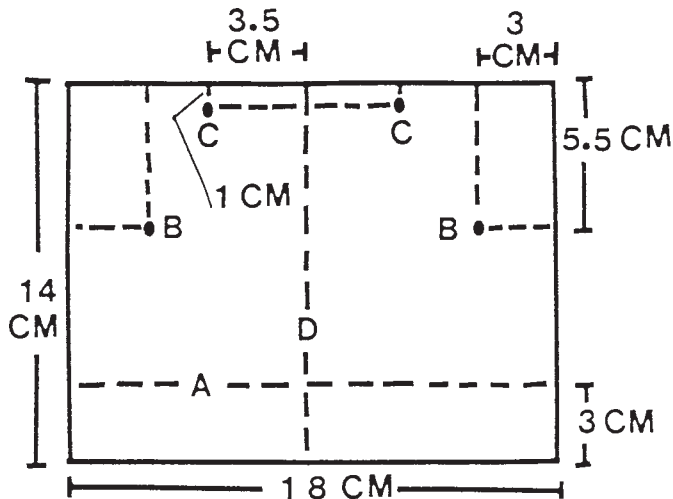

A = Distance the face overhangs the sides,
 B = 0.44 cm (1/64 in.) hole,
 C = 0.20 cm (5/64 in.) pilot hole, and
 D = Centerline of face.

Inch Pound Equivalents

cm	in.	cm	in.
1	0.4	10	3.9
3	1.2	14	5.5
3.5	1.4	18	7.0
5.5	2.1	20	7.8
8.3	3.2		

FIG. A1.5 Schematic Diagram of the Face of the Base

cm (0.32 in.) above the upper plane of the face. Two of the round-head screws can be seen holding up the hoop in Fig. A1.1.

A1.3.11 Apply two coats of a water-resistant finish to side A, side B, the face, and all the parts of the hoops if the hoops are made of wood. Allow all of the coated parts to dry.

A1.3.12 Insert the three carriage bolts through the holes in side A and then side B. As shown in Fig. A1.2, each bolt uses three sets of washers and nuts to space the sides about 10.5-cm (4.1-in.) apart (measure from the inner dimensions of the

wood; the exact distance depends on the exact location of the holes in the face). Bolts, nuts, and washers must be loose at this point so the two sides can slide on the bolts.

A1.3.13 As shown in Fig. A1.2, place the face on the sides so that the top back edge of the face is lined up with the top of the sides (if the wood is not the specified width some adjustments can be made here, the critical factors are the face must overhang the pan and the hoop must overhang the face as described in A1.3.7). This will produce a 3.0-cm (1.2-in.) overhang of the face over the sides (see the overhang line on Fig. A1.5). Push the flat-head screws through the holes in the face and tap the head of the screws with a hammer to mark the location of the holes on the 1.1 rad (60°) sides A and B. This mark must be centered in relation to the 1.9 cm depth (0.75) of side A and side B. Drill these marks with a 0.20-cm (5/64-in.) drill bit to obtain the necessary pilot holes. Bolt the face to the sides using the flat-head wood screws.

A1.3.14 Tighten the nuts on the carriage bolts to obtain two sides which are parallel. Check the angle of the face to be sure the face is 1.1 rad (60°). Shims can be placed between the face and the sides to make small adjustments in this angle.

A1.3.15 As shown in Fig. 4 in the test method, and Fig. A1.3, place a laboratory sampling unit between the inner and outer hoops and then place the hoop/specimen assembly on the base so the round-head wood screws support the hoop/specimen assembly in the proper location. Slide the base/hoop/specimen assembly near the pour spout on the graduate attached to the apparatus (see Fig. A1.3). Using the clamp holder on the horizontal rod and the combination utility and “burette” clamp, position the pour spout so it is located as shown in Fig. 1 in the test method.

A1.3.16 Slide two tubing clamps on the tubing attached to the funnel. Cut the tubing attached to the funnel to the proper length and attach it to the valve or stopcock. Fasten the tubing to the fitting on the funnel and the valve or stopcock with the two tubing clamps.

A1.3.17 Recheck all the clamps, bolts, and screws to be sure they are tight.

The American Society for Testing and Materials takes no position respecting the validity of any patent rights asserted in connection with any item mentioned in this standard. Users of this standard are expressly advised that determination of the validity of any such patent rights, and the risk of infringement of such rights, are entirely their own responsibility.

This standard is subject to revision at any time by the responsible technical committee and must be reviewed every five years and if not revised, either reapproved or withdrawn. Your comments are invited either for revision of this standard or for additional standards and should be addressed to ASTM Headquarters. Your comments will receive careful consideration at a meeting of the responsible technical committee, which you may attend. If you feel that your comments have not received a fair hearing you should make your views known to the ASTM Committee on Standards, at the address shown below.

This standard is copyrighted by ASTM, 100 Barr Harbor Drive, PO Box C700, West Conshohocken, PA 19428-2959, United States. Individual reprints (single or multiple copies) of this standard may be obtained by contacting ASTM at the above address or at 610-832-9585 (phone), 610-832-9555 (fax), or service@astm.org (e-mail); or through the ASTM website (www.astm.org).