



Standard Test Method for Shrinkage of Textile Fibers (Single-Fiber Test)¹

This standard is issued under the fixed designation D 5104; the number immediately following the designation indicates the year of original adoption or, in the case of revision, the year of last revision. A number in parentheses indicates the year of last reapproval. A superscript epsilon (ϵ) indicates an editorial change since the last revision or reapproval.

1. Scope

1.1 This test method covers the measurement of the shrinkage of crimped or uncrimped single staple fibers when exposed to hot air or to near the boiling point of water.

NOTE 1—For shrinkage of fibers by the bundle test, refer to Test Method D 2102.

1.1.1 This test method is also used on staple fibers and filaments removed from tow or yarn.

1.2 The values stated in either SI units or inch-pound units are to be regarded separately as standard. The values stated in either system are not exact equivalents; therefore, each system must be used independently of the other.

1.3 *This standard does not purport to address all of the safety concerns, if any, associated with its use. It is the responsibility of the user of this standard to establish appropriate safety and health practices and determine the applicability of regulatory limitations prior to use.*

2. Referenced Documents

2.1 ASTM Standards:

- D 123 Terminology Relating to Textiles²
- D 1577 Test Methods for Linear Density of Textile Fibers²
- D 1776 Practice for Conditioning Textiles and Textiles for Testing²
- D 2102 Test Method for Shrinkage of Textile Fibers (Bundle Test)²
- D 2258 Practice for Sampling Yarn for Testing²
- D 3333 Practice for Sampling Man-Made Staple Fibers, Sliver, or Tow for Testing³

2.2 ASTM Adjuncts: TEX-PAC⁴

3. Terminology

3.1 Definitions:

3.1.1 *shrinkage, n*—a decrease in one or more dimensions of an object or material.

¹ This test method is under the jurisdiction of ASTM Committee D 13 on Textiles and is the direct responsibility of Subcommittee D13.58 on Yarn and Fiber Test Methods.

Current edition approved Sept. 10, 1996. Published January 1997. Originally published as D 5104 – 90. Last previous edition D 5104 – 96.

² *Annual Book of ASTM Standards*, Vol 07.01.

³ *Annual Book of ASTM Standards*, Vol 07.02.

⁴ PC Programs on floppy disks are available through ASTM. For a 3½-in. disk request PCN: 12-429040-18.

3.1.1.1 *Discussion*—In this test method, the decrease is in the length; however, in some cases, there is an increase in length rather than a decrease. This increase is referred to as a growth or negative shrinkage.

3.1.2 For definitions of other terms used in this test method, see Terminology D 123.

4. Summary of Test Method

4.1 A conditioned single fiber is lightly loaded between clamps and the nip-to-nip length measured. Without being removed from the clamps, the fiber is relieved of the load and exposed to the test environment, typically, water near boil or hot air at specified temperature for a specified length of time. After reconditioning, the fiber length is remeasured under the same loading and the shrinkage is calculated.

5. Significance and Use

5.1 This test method may be used for acceptance testing of commercial shipments of textile fibers, however caution is advised because information about between-laboratory precision is incomplete. Comparative tests as directed in 5.1.1 may be advisable. See Section 13 for single-laboratory information.

5.1.1 In case of a dispute arising from differences in reported test results when using this test method for acceptance testing of commercial shipments, the purchaser and supplier should conduct comparative tests to determine if there is a statistical bias between their laboratories. Competent statistical assistance is recommended for the investigation of bias. As a minimum, the two parties should take a group of test specimen that are as homogeneous as possible and that are from a lot of material of the type in question. The test specimen should then be randomly assigned in equal numbers to each laboratory for testing. The average results from the two laboratories should be compared using Student's *t*-test for unpaired data and an acceptable probability level chosen by the two parties before the testing began. If a bias is found, either its cause must be found and corrected or the purchaser and the supplier must agree to interpret future test results in light of the known bias.

5.2 This test method is applicable to all single fibers. Due to variability of individual fiber shrinkage, it is recommended that a large number of fibers of the same material be tested to reduce errors in estimating shrinkage.

5.3 Results obtained by this test method can be used for the following purposes:

5.3.1 As an aid in predicting the dimensional stability of

fabrics to wet processing,

5.3.2 As an aid in predicting the dimensional stability of fabrics during processing at elevated temperatures, and

5.3.3 As a control measure in the manufacture of some types of fibers.

6. Apparatus and Materials

6.1 *Single Fiber Shrinkage Apparatus*, consisting of a device to hold a number of fibers individually in place at one end with a clamping mechanism. The apparatus shall have a means to remove strain from the fibers while they are being exposed to the testing medium. Scales for measuring the fiber length may be inscribed at each test site or a cathetometer (6.4) may be used. In either case, the scale used must measure at least 50-mm lengths and be capable for estimating the length to the nearest 0.5 mm. An example of apparatus using a magnetic bar clamping mechanism is shown in Fig. 1. Another type of clamping mechanism that is being used is the post-and-hole type.

6.2 *Clips*, of known mass, made of magnetic alloy and suitable for extending the test fibers by applying a light load. The clips shall be calibrated to apply a tension of 1.0 CN/tex (0.1 gf/d). For example, a fiber that is 1.1 dtex (1 den) would require a clip with a mass of 0.1 g.

6.3 *High Temperature Tape*,⁵ for anchoring the test fibers under the removable bar of the apparatus, as shown in Fig. 1.

6.4 *Cathetometer*,⁶ used for sighting the filament's length if increased precision is needed.

6.5 *Specimen Board*, a 20 by 20-cm board covered with shortpile fabric of contrasting color to the fiber being analyzed.

6.6 *Oven*, ventilated and capable of maintaining the test temperature within $\pm 2^{\circ}\text{C}$ (5°F), for hot air testing.

⁵ A tape satisfying these requirements is obtainable from Top Flight Corp., P.O. Box 472, York, PA 17405. The tape is Micals S-940, which is a polyester film containing a high-temperature adhesive.

⁶ A cathetometer satisfying this option can be purchased from many of the scientific apparatus companies, for example, Thomas Scientific, Vine Street at Third, P.O. Box 779, Philadelphia, PA 19105.

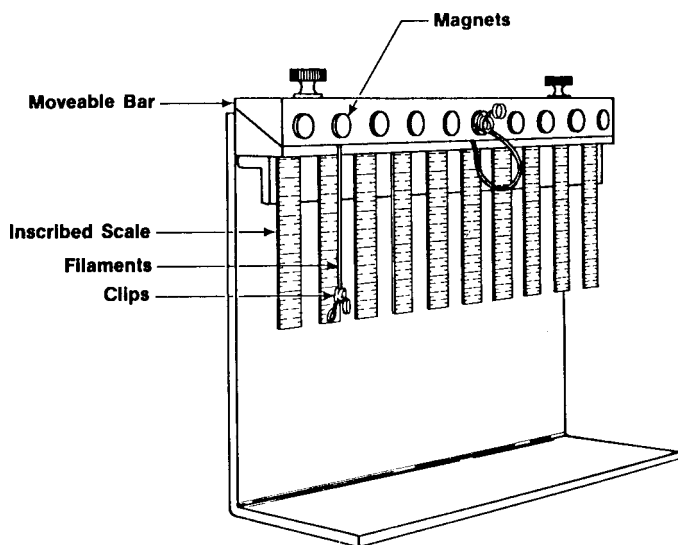

FIG. 1 Jig for Determining Single Fiber Shrinkage

6.7 *Water Bath*, capable of maintaining the test temperature within $\pm 1^{\circ}\text{C}$ (2°F), for hot or boiling water testing.

7. Sampling

7.1 *Lot Sampling*—As a lot sample for acceptance testing, take at random the number of shipping containers directed in the applicable material specification or other agreement between the purchaser and supplier, such as an agreement to use Practice D 3333 or Practice D 2258, as appropriate. Consider shipping containers to be the primary sampling units.

NOTE 2—An adequate specification or other agreement between the purchaser or supplier requires taking into account the variability between shipping units, between packages, ends or other laboratory sampling units within a shipping unit if applicable, and within specimens from single package, end or other laboratory sampling units to provide a sampling plan with a meaningful producer's risk, consumer's risk, acceptable quality level, and limiting quantity level.

7.2 *Laboratory Sample*—As a laboratory sample for acceptance testing, take at random from each shipping container in the lot sample the number of laboratory sampling units as directed in an applicable material specification or other agreement between the purchaser and supplier such as an agreement to use Practice D 3333 or Practice D 2258, as appropriate. Preferably, the same number of laboratory sampling units are taken from each shipping container in the lot sample. If differing numbers of laboratory sampling units are to be taken from shipping containers in the lot sample, determine at random which shipping containers are to have each number of laboratory units drawn.

7.2.1 *For Staple Fiber*—Take 50-g samples from laboratory units.

7.2.2 *For Sliver (or Top) or Tow*—Take 1 m from the leading end which has a clean, uniform appearance.

7.2.3 *For Yarns*—Prepare at least a 50-m skein from each package.

7.3 *Test Specimens*—From each laboratory sampling unit, take ten specimens at random. If the standard deviation determined for the ten specimens is more than a value agreed upon between the purchaser and supplier, continue testing in groups of ten specimens from the same laboratory sampling unit until the standard deviation for all specimens tested is not more than the agreed to value or, by agreement, stop testing after a specified number.

7.3.1 Carefully remove twist before taking specimens from yarn. Using tweezers and grasping the specimens at the ends, gently remove the required number of specimens from the laboratory sampling units for testing. In some cases, if specimens are not to be tested immediately, place them on an identified specimen board for storage until ready to test.

8. Preparation of Test Specimen

8.1 Determine the average linear density in tex(denier) as prescribed in Test Method D 1577, if the linear density is not known.

8.2 Weigh a series of clips to ensure that the clips are of the correct mass for the fiber to be tested for shrinkage.

8.3 Take the specimens at random from the laboratory sample.

8.4 Place the fibers on a preparation board.

 **D 5104**

9. Conditioning

9.1 Precondition and condition the laboratory samples as directed in Practice D 1776.

10. Procedure

10.1 Make all length measurements on specimens in the standard atmosphere for testing textiles which is $21 \pm 1^\circ\text{C}$ ($70 \pm 2^\circ\text{F}$) and $65 \pm 2\%$ relative humidity.

10.2 Without stretching the fibers, place a clip of correct mass for the fiber being tested on one end of each fiber. Any stretching will influence the results.

10.3 Place a piece (6.5 by 6.5 mm) of high-temperature tape on the other end of each filament allowing at least 25 mm between the tape and the clip.

10.4 Remove the moveable bar from the top of the apparatus and stick the taped end of the fiber on to the frame of the apparatus at a fiber test site, with the lower edge of the tape aligned just at the edge of the frame.

10.5 Replace the moveable bar on the apparatus to clamp the fibers in place.

10.6 Allow the fibers to extend to their full length in front of the inscribed scales of the apparatus.

10.7 Measure the length of the extended fiber to the nearest 0.5 mm using the inscribed scale on the apparatus. The nip of the moveable bar is the zero reference point and the position of the nip of the clip is the fiber's extended length.

10.8 Record the length.

NOTE 3—For improved precision, a cathetometer may be used to measure the length of the extended fibers.

10.9 Relax the fibers by placing the clips on the magnets of the removable bar.

10.10 Expose the specimens mounted in the holder to the test environment, as specified; for example, hot air at $190 \pm 2^\circ\text{C}$ ($374 \pm 5^\circ\text{F}$) or hot water at $98 \pm 1^\circ\text{C}$ ($208 \pm 2^\circ\text{F}$) for 15 min.

10.11 Remove the specimen holder from the test environment and return the specimens, in the holder, to moisture equilibrium with the standard atmosphere for testing.

10.12 Release the clips from the magnets, with care to prevent stretching the fibers.

10.13 Repeat the procedure described in 10.6 and 10.7 to measure the length after treatment.

11. Calculation

11.1 Calculate the shrinkage for each specimen to the nearest 0.01 % using Eq 1:

$$S = [(B - A)/B] \times 100 \quad (1)$$

where:

S = shrinkage, %,

B = specimen length before treatment, mm (in.), and

A = specimen length after treatment, mm (in.).

11.2 Calculate the average shrinkage for each laboratory sampling unit and for the lot.

11.3 Calculate the standard deviation or coefficient of variation, or both, for each laboratory sample unit and the lot, if requested.

12. Report

12.1 State that the specimens were tested in accordance with Test Method D 5104. Describe the materials or product sampled, and the method of sampling used.

12.2 Report the following information:

12.2.1 Shrinkage, for each sample unit and for the lot,

12.2.2 Standard deviation and coefficient of variation, or both, if calculated,

12.2.3 Shrinkage test conditions (medium, temperature, and time),

12.2.4 Number of observations,

12.2.5 Mass of clips used, and

12.2.6 Linear density of the fiber.

13. Precision and Bias

13.1 *Summary*—Based on limited information from one laboratory, the single-operator and within-laboratory components of variance and critical differences shown in Tables 1 and 2 are approximate. These tables are constructed to illustrate what one laboratory found when all the observations are made by the same well-trained operator using the same apparatus and specimens randomly drawn from the sample of material. For this laboratory, in comparing two averages, the differences should not exceed the single-operator precision values shown in Table 2 for the respective number of tests in 95 out of 100 cases. Differences for other laboratories may be larger or smaller. The number of laboratories available to perform this test method has diminished over the last few years. If additional laboratories are identified to perform this test, between-laboratory precision will be established.

13.2 *Single-Laboratory Test Data*—A single-laboratory test was run in 1995 in which randomly-drawn samples of two materials, two packages per material, were tested. Two operators in the laboratory each tested twenty specimens from each package of each material using Test Method D 5104. Ten of the twenty specimens were tested on one day and the remaining ten specimens on a second day. The data were analyzed using Practice D 2904. The components of variance for hot air shrinkage, expressed as standard deviations, are shown in Table 1. The two fiber types were:

Material S1S2—Polyester Staple, 1.2 dpf, 1.5 in.

Material S3S4—Acrylic Staple, Hi-Bulk, Crimped.

13.3 *Precision*—Since tests were conducted in only one laboratory, estimates of between-laboratory precision may be either underestimated or overestimated to a considerable extent and should be used with special caution. Before a meaningful statement can be made about two specific laboratories, the amount of statistical bias, if any, between them must be

TABLE 1 Components of Variance for Fiber Shrinkage to Hot Air at 190°C (374°F)

| Material | Average, % | Components of Variance ^A | |
|---|------------|-------------------------------------|-------------------|
| | | Single-Operator | Within-Laboratory |
| Polyester Staple, 1.2 dpf, 1.5 in. (mm) | 2.51 | 0.98 | 0.28 |
| Acrylic Staple, hi-bulk, crimped | 11.28 | 4.27 | 0.00 |

^AThe standard deviations (square roots of the components of variance) are given to express the variability in the appropriate units of measure rather than the squares of those units of measure.



TABLE 2 Critical Differences^A for Fiber Shrinkage to Hot Air at 190°C (374°F)

| Material | Number of Observations in Each Sample | Critical Difference | |
|---|---------------------------------------|---------------------|-------------------|
| | | Single-Operator | Within-Laboratory |
| Polyester Staple, 1.2 dpf, 1.5 in. (mm) | 1 | 2.72 | 2.83 |
| | 2 | 1.92 | 2.07 |
| | 5 | 1.22 | 1.44 |
| | 10 | 0.86 | 1.15 |
| Acrylic Staple, hi-bulk, crimped | 1 | 11.85 | 11.85 |
| | 2 | 8.35 | 8.38 |
| | 5 | 5.30 | 5.30 |
| | 10 | 3.75 | 3.75 |

^AThe critical differences were calculated using $t = 1.960$, that is based on infinite degrees of freedom.

established, with each comparison being based on recent data obtained on samples taken from a lot of material of the type being evaluated to be as nearly homogeneous as possible and

then randomly assigned in equal numbers to each of the laboratories. However, when agreed upon between the contractual parties, for the approximate components of variance observed in Table 1, two averages of observed values may be considered significantly different at the 95 % probability level if the difference equals, or exceeds, the critical differences listed in Table 2. There were significant differences related to the material type and structure to warrant listing the components of variance and the critical differences separately. Consequently, no multi-material comparisons were made.

13.4 *Bias*—The value for shrinkage of textile fibers can only be defined in terms of a test method. Within this limitation, this test method has known bias.

14. Keywords

14.1 dimensional change; textile fibers

The American Society for Testing and Materials takes no position respecting the validity of any patent rights asserted in connection with any item mentioned in this standard. Users of this standard are expressly advised that determination of the validity of any such patent rights, and the risk of infringement of such rights, are entirely their own responsibility.

This standard is subject to revision at any time by the responsible technical committee and must be reviewed every five years and if not revised, either reapproved or withdrawn. Your comments are invited either for revision of this standard or for additional standards and should be addressed to ASTM Headquarters. Your comments will receive careful consideration at a meeting of the responsible technical committee, which you may attend. If you feel that your comments have not received a fair hearing you should make your views known to the ASTM Committee on Standards, at the address shown below.

This standard is copyrighted by ASTM, 100 Barr Harbor Drive, PO Box C700, West Conshohocken, PA 19428-2959, United States. Individual reprints (single or multiple copies) of this standard may be obtained by contacting ASTM at the above address or at 610-832-9585 (phone), 610-832-9555 (fax), or service@astm.org (e-mail); or through the ASTM website (www.astm.org).