



Standard Specification for Poly(Vinyl Chloride) Resins¹

This standard is issued under the fixed designation D 1755; the number immediately following the designation indicates the year of original adoption or, in the case of revision, the year of last revision. A number in parentheses indicates the year of last reapproval. A superscript epsilon (ϵ) indicates an editorial change since the last revision or reapproval.

1. Scope

1.1 This specification covers the establishment of requirements for homopolymers of vinyl chloride in original powder form intended for subsequent mixing and processing in thermoplastic compositions. These resins have a nominal specific gravity of 1.4 and a theoretical chlorine content of 56.8 %.

1.2 Two types of resin have been recognized: general purpose and dispersion. When mixed with the customary amount of plasticizer, general-purpose resins yield a dry or moist powder while dispersion resins yield a liquid slurry. Since many resins are polymerized to meet special requirements, a system of classification has been provided that permits a wide choice of grades.²

1.3 The values stated in SI units are to be regarded as the standard.

NOTE 1—This standard is similar in content (but not technically equivalent) to ISO 1264 – 1980.³

1.4 *This standard does not purport to address all of the safety problems, if any, associated with its use. It is the responsibility of the user of this standard to establish appropriate safety and health practices and determine the applicability of regulatory limitations prior to use.*

2. Referenced Documents

2.1 ASTM Standards:

- D 281 Test Method for Oil Absorption of Pigments by Spatula Rub-Out⁴
- D 495 Test Method for High-Voltage, Low-Current, Dry Arc Resistance of Solid Electrical Insulation^{5, 6}
- D 883 Terminology Relating to Plastics⁶

¹ This specification is under the jurisdiction of ASTM Committee D20 on Plastics and is the direct responsibility of Subcommittee D20.15 on Thermoplastic Materials (Section D20.15.07).

Current edition approved June 15, 1992. Published August 1992. Originally published as D1755 – 60 T. Last previous edition D1755 – 81 (1987).

² Hutson, J. L., "Proposed Method for Classifying Poly(Vinyl Chloride) Resins." ASTM Research Report File No. RR: D-20-1: (May 20, 1959). Available from ASTM Headquarters.

³ Available from American National Standards Institute, 11 W. 42nd St., 13th Floor, New York, NY 10036.

⁴ *Annual Book of ASTM Standards*, Vol 06.02.

⁵ *Annual Book of ASTM Standards*, Vol 10.02.

⁶ *Annual Book of ASTM Standards*, Vol 08.01.

- D 1125 Test Methods for Electrical Conductivity and Resistivity of Water⁷
- D 1243 Test Method for Dilute Solution Viscosity of Vinyl Chloride Polymers⁶
- D 1249 Specification for Octyl Ortho-Phthalate Ester Plasticizers⁶
- D 1600 Terminology for Abbreviated Terms Relating to Plastics⁶
- D 1705 Test Method for Particle Size Analysis of Powdered Polymers and Copolymers of Vinyl Chloride⁶
- D 1755 Specification for Poly(Vinyl Chloride) Resins⁶
- D 1823 Test Method for Apparent Viscosity of Plastics and Organosols at High Shear Rates by Extrusion Viscometer⁶
- D 1824 Test Method for Apparent Viscosity of Plastics and Organosols at Low Shear Rates by Brookfield Viscometer⁶
- D 1895 Test Methods for Apparent Density, Bulk Factor, and Pourability of Plastic Materials⁶
- D 1898 Practice for Sampling of Plastics⁶
- D 1921 Test Method for Particle Size (Sieve Analysis) of Plastic Materials⁶
- D 2132 Test Method for Dust-and-Fog Tracking and Erosion Resistance of Electrical Insulating Materials⁵
- D 2396 Test Method for Powder-Mix Test of Poly(Vinyl Chloride) (PVC) Resins Using a Torque Rheometer⁸
- D 2873 Test Method for Interior Porosity of Poly(Vinyl Chloride) (PVC) Resins by Mercury Intrusion Porosimetry⁸
- D 3030 Test Method for Volatile Matter (Including Water) of Vinyl Chloride Resins⁸
- D 3892 Practice for Packaging/Packing of Plastics⁸
- E 1 Specifications for ASTM Thermometers⁹

3. Terminology

3.1 *Definitions*—Definitions are in accordance with Terminology D 883 and Terminology D 1600, unless otherwise indicated.

⁷ *Annual Book of ASTM Standards*, Vol 11.01.

⁸ *Annual Book of ASTM Standards*, Vol 08.02.

⁹ *Annual Book of ASTM Standards*, Vol 14.03.

4. Classification

4.1 *Types*—This specification covers two types of resin:

4.1.1 *Type GP*—General-purpose resins primarily intended for either dry blending, preblending, or thermoplastic processing.

for each property in the order in which they are listed in Table 1 and Table 2. Where there is no interest in a property, a “0” is entered in place of a cell number. Should it be desirable, a cell limit may be extended by half the cell range into the next higher or lower cell, but not both. When this is done, it is

TABLE 1 Type GP, General-Purpose Resin Requirements

Designation Order No.	Property	Cell Limits										
		0	1	2	3	4	5	6	7	8	9	
1	Dilute solution (inherent) viscosity	unspecified	<0.70	0.70 to 0.79	0.80 to 0.89	0.90 to 0.99	1.00 to 1.09	1.10 to 1.19	1.20 to 1.29	1.30 to 1.39	≥1.40	
2	Sieve analysis, percent through No. 200 (75-μm) sieve	unspecified	0 to 9	10 to 19	20 to 29	30 to 39	40 to 49	50 to 59	60 to 79	80 to 99	100	
3	Apparent (bulk) density:	g/1000 cm ³	unspecified	<144	144 to 232	233 to 328	329 to 425	426 to 520	521 to 616	617 to 712	713 to 808	≥809
		lb/ft ³	unspecified	<9.00	9.00 to 14.50	14.51 to 20.50	20.51 to 26.50	26.51 to 32.50	32.51 to 38.50	38.51 to 44.50	44.51 to 50.50	≥50.51
4	Plasticizer sorption, parts DOP phr ^A	unspecified	<50	50 to 74	75 to 99	100 to 124	125 to 149	150 to 174	175 to 199	200 to 244	≥225	
5	Dry flow, s/400 cm ³	unspecified	<2.0	2.0 to 3.9	4.0 to 5.9	6.0 to 7.9	8.0 to 9.9	≥10	...	
6	Conductivity, max, μS/cm-g	unspecified	<6	≥6	

^A phr = per 100 parts of resin.

TABLE 2 Type D, Dispersion Resin Requirements

Designation Order No.	Property	Cell Limits									
		0	1	2	3	4	5	6	7	8	9
1	Dilute solution (inherent) viscosity	unspecified	<0.90	0.90 to 0.99	1.00 to 1.09	1.10 to 1.19	1.20 to 1.29	1.30 to 1.39	1.40 to 1.49	1.50 to 1.59	≥1.60
2	Brookfield viscosity (RVF), poise	unspecified	0 to 24	25 to 49	50 to 74	75 to 99	100 to 124	125 to 149	150 to 174	175 to 199	>199
3	Severs viscosity, poise	unspecified	0 to 49	50 to 99	100 to 149	150 to 199	200 to 299	300 to 499	500 to 999	1000 to 1499	>1499

TABLE 3 Requirements of Resin GP6-43054

Designation Order No.	Property	Unit	Requirement		Cell Code
			min	max	
1	Inherent viscosity		1.10	1.19	6
2	Sieve analysis	percent through No. 200 (75-μm) sieve	30	44 (39 + 10/2)	4
3	Apparent (bulk) density	g/1000 cm ³ (lb/ft ³)	233 (14.51)	328 (20.50)	3
4	Plasticizer sorption	parts DOP phr ^A	none		0
5	Dry flow	s/400 cm ³	3.0 (4.0-2.0/2)	5.9	5
6	Conductivity	μS/cm-g	...	≥6	4

^A phr = per 100 parts of resin.

4.1.2 *Type D*—Dispersion resins primarily intended for use in organosols and plastisols. As a class, these are small in particle size.

4.2 *Grades*—This specification provides for as many grades of resin as may be selected from the possible combinations of requirements in Table 1 and Table 2. A grade is designated by first indicating the type (GP or D), followed by cell numbers

indicated by a dash above the cell number (\bar{n}) if the extension is into the higher cell, or a dash below (n) if into the lower cell. Extension of cell limits applies only to cells where ranges of properties are allowed and not where maximum or minimum values are specified. The cell number of the first property (dilute solution viscosity) is separated from those that follow by a dash.

NOTE 2—Resin GP643054. This is a grade of general-purpose resin (see Table 1) having the requirements given in Table 3.¹⁰ Standard values defined by round-robin testing of eight laboratories are listed in Table 4.

5. General Requirements

5.1 The resin shall be in powder form.

5.2 The resin shall conform to the requirements of Table 1 or Table 2, as specified by the type and grade designation agreed upon between the purchaser and the supplier.

NOTE 3—Properties not covered, such as heat stability, color, and volatile loss, may also be important for application performance in compounds.

6. Sampling

6.1 Unless otherwise agreed upon between the purchaser and the supplier, the material shall be sampled in accordance with the sampling procedure in Practice D 1898.

7. Number of Tests

7.1 One set of test specimens as prescribed in the Sections on General and Specific Sampling Procedures of Practice D 1898 shall be considered sufficient for testing each batch.

8. Retest and Rejection

8.1 If any failure occurs, the materials may be retested to establish conformity in accordance with an agreement between the purchaser and the supplier.

TEST METHODS

9. Dilute Solution Viscosity

9.1 Test Method D 1243.

10. Apparent (Bulk) Density

10.1 Test Methods D 1895.

11. Sieve Analysis

11.1 Test Method D 1921.

NOTE 4—Test Method D 1705 may be substituted at the option of the purchaser and the supplier.

NOTE 5—Specifications for sieve analysis (Table 1) are primarily intended to control fines.

¹⁰ ASTM General Purpose PVC Reference Standard is available from B. F. Goodrich Chemical Co., Manufacturing Services Laboratory, P.O. Box 134, Avon Lake, OH 44012.

**TABLE 4 ASTM PVC Reference Standard No. 1
(General Purpose)**

NOTE 1—The cell classification of this standard is GP5-15443.

	Method	Accepted Value ^A
Inherent viscosity	D 1243	1.018 ± 0.012
Percent through No. 200 sieve	D 1921	1.3 ± 0.4
Apparent density, g/1000 cm ³	D 1895	503 ± 5
Plasticizer sorption, phr	D 1755	101 ± 6
Dry flow, s/400 cm ³	D 1755	2.6 ± 0.2
Conductivity, μS/cm-g	D 1755	1.0 ± 0.3
Porosity, cm ³ /g	D 2873	0.268 ± 0.022
Powder mix time, s	D 2396	163 ± 17

^A Expected range for mean of two replicates (within a probability of 99.5 %).

12. Brookfield Viscosity

12.1 Test Method D 1824. Take readings using a Brookfield RVF viscometer at 20 r/min with a No. 6 spindle. Prepare the plastisol sample as follows:

12.1.1 *Plasticizer*—Di (2-ethylhexyl) phthalate (DOP), Type I in Specification D 1249.

12.1.2 *Apparatus*:

12.1.2.1 *Mixer*, planetary-gear type, equipped with flat beater mixing paddle.¹¹

12.1.2.2 *Vacuum Desiccator*, capable of being evacuated to 133 Pa (1 mm Hg).

12.1.3 *Procedure*:

12.1.3.1 Condition the mixing bowl and materials to 23 ± 1°C. Weigh 500 ± 0.5 g of resin into the mixing bowl. Weigh 300 ± 0.5 g of plasticizer and add it directly on top of the resin in the mixing bowl. Hand mix with the flat beater for 1 min.

12.1.3.2 Mount the bowl on the mixer and mix for 5 min at the No. 1 speed. Stop the mixer and scrape down the sides of the bowl and the beater. Resume mixing at the No. 2 speed for an additional 15 min. Note and record the temperature of the plastisol immediately after mixing. The temperature rise must not exceed 5°C. Use a cooling bath if necessary.

12.1.3.3 Place the mixing bowl in the desiccator, evacuate to 133 Pa (1 mm Hg), and allow it to remain in the desiccator for an additional 10 min after the foam collapses. Consider the time in the desiccator as part of the normal aging period. Take care to ensure that the plastisol does not overflow the container during evacuation.

13. Severs Viscosity

13.1 Test Method D 1823. Determinations shall be made through a 3.17 ± 0.13-mm (0.125 ± 0.005-in.) diameter orifice at a gas pressure of 0.69 MPa (100 psi). The plastisol sample shall be prepared in accordance with 12.1.1-12.1.3.

14. Electrical Conductivity of Water Extract

14.1 *Definitions*—See the Definitions Section of Test Methods D 1125.

14.2 *Summary of Test Method*—This test is intended to distinguish between electrical and nonelectrical grades of unprocessed resin. In general, the test will not detect relatively small differences among different lots of electrical grade resin. A water dispersion of the resin is boiled for a short time and the electrical conductivity of the solution measured. The conductivity of the water extract results from ionic impurities in the resin that adversely affect its use for electrical insulation.¹² Electrical grade resins generally yield conductivity values less than 6 μS/cm-g.

14.3 *Apparatus*:

14.3.1 *A-C Wheatstone Bridge*, having a range up to 250 000Ω, a 100 ± 50-Hz oscillator and a sensitive null point indicator with minimum accuracy of ± 2 %.

¹¹ A Hobart Model N-50, manufactured by the Hobart Manufacturing Co., Troy, OH, has been found satisfactory for this purpose.

¹² DeCoste, J. B., and Siratelli, B. A., "Characterization of PVC Resins by the Conductivity of Solvent Extract," *Rubber Age*, Vol 87, pp. 279-285.

14.3.2 *Dip Cell*,¹³ having platinum electrodes and a cell constant of about 0.1 cm^{-1} , similar to the one shown in Fig. 1.



FIG. 1 Dip Cell for Electrical Conductivity Test

The cell shall be prepared and calibrated in accordance with Test Method D 495.

14.3.3 *Thermometer*, equivalent to or better than ASTM Partial Immersion Thermometer, having a range from -20 to $+150^\circ\text{C}$ and conforming to the requirements for Thermometer 1C in accordance with Specifications E 1.

14.3.4 *Electric Hot Plate*.

14.4 *Reagents*:

14.4.1 *High-Purity Water*—Water having a conductivity not greater than $1.0 \mu\text{S/cm}$, prepared in accordance with Test Method D 2132.

NOTE 6—A high-purity water may also be obtained by passing ordinary distilled water through a dual-bed ion exchange column packed with an appropriate resin.¹⁴

14.4.2 *Isopropyl Alcohol*, ACS reagent grade.

14.5 *Procedure*:

14.5.1 Place a resin sample weighing $2.00 \pm 0.01 \text{ g}$ in a 250-mL Erlenmeyer flask that has previously been rinsed twice with boiling, high-purity water. Add $5.0 \pm 0.5 \text{ mL}$ of isopropyl alcohol to the sample, and swirl the mixture until the resin is uniformly wet. Add $100 \pm 1 \text{ mL}$ of boiling, high-purity water, set a watch glass on top of the flask, and boil gently for 5 min. Cool rapidly to $23 \pm 1^\circ\text{C}$. Allow the resin to settle, and then place the dip cell in the flask so that the electrodes are completely immersed, as shown in Fig. 2. Measure the resis-



FIG. 2 Dip Cell Immersed in Flask

tance on the most sensitive scale of the bridge after 30-s immersion. Perform determinations in duplicate.

14.5.2 Between measurements, rinse the cell thoroughly in high-purity water and gently shake off any water clinging to the surface.

14.5.3 *Blank*—Make duplicate parallel determinations using 5 mL of isopropyl alcohol and 100 mL of high-purity water.

14.5.4 *Calculation*—Calculate the electrical conductivity of the extract solution as follows:

$$\text{Electrical conductivity, } \mu\text{S/cm}\cdot\text{g} = [(L/R_2 - L/R_3)/m] \times 10^6$$

where:

¹³ The cell illustrated is a Leeds and Northrup Conductivity Cell No. 4920. Other cells are available from Beckman Instruments, Inc., Cedar Grove, NJ 07009, and Rutherford Research Products Co., Rutherford, NJ 07070.

¹⁴ Amberlite MB-1, available from the Rohm and Haas Co., Philadelphia, PA, is satisfactory for this purpose.

- L = cell constant,
- R_2 = resistance, Ω , of extract solution,
- R_3 = resistance, Ω , of blank, and
- m = sample weight, g.

14.6 *Report*—Report the average of duplicate determinations of electrical conductivity in $\mu\text{S}/\text{cm}\cdot\text{g}$ of sample.

14.7 *Precision and Bias*—The precision of the test method, calculated by analysis of the round-robin data from four laboratories, is as follows:

14.7.1 *Repeatability*—Coefficient of variation (average of replicates) within a laboratory of 14.7 %.

14.7.2 *Reproducibility*—Coefficient of variation (average of replicates) between laboratories of 17.2 %.

15. Plasticizer Sorption

15.1 *Scope*—This test method covers the measurement of the amount of plasticizer that a resin can absorb at the standard laboratory temperature. Plasticizer sorption is one of the parameters for judging the dry blending properties of a resin. This test method is similar in many respects to that employed in Test Method D 281.

15.2 *Apparatus*:

15.2.1 *Platform Scales or Balance*, 0.01-g accuracy.

15.2.2 *Glass or Glazed Porcelain Plate*, 254 by 254 by 6.4 mm (10 by 10 by 0.25 in.), minimum.

15.2.3 *Spatula*, with width and shape to fit mold cavity (see Fig. 3).

15.2.4 *Dropping Bottle*, 60-mL capacity.

15.2.5 *Mold*, aluminum or brass, as shown in Fig. 3.

15.3 *Plasticizer*—Di(2-ethylhexyl)-phthalate (DOP), Type I in Specification D 1249.

15.4 *Conditioning*—Determine plasticizer sorption at the Standard Laboratory Temperature of $23 \pm 1^\circ\text{C}$.

15.5 *Procedure*—Weigh 5 ± 0.01 g of resin and transfer it to the plate. Obtain the gross weight, to the nearest 0.01 g of the dropping bottle about half full of DOP. Begin adding the DOP to the resin in 1-mL increments, using the spatula for mixing after each. When 4 mL have been added, change the

rate to two drops at a time, making consistency determinations until the end point is reached. This is done by filling the mold, as it rests on the plate, with the mixture and then sliding the spatula under the charge. Lift the charge above the mold cavity with the spatula horizontal, and then rotate the blade to a vertical position. The end point is reached when the mixture first slides off the blade. At this point, reweigh the dropping bottle and its contents. Make duplicate determinations.

NOTE 7—The mix portions used for consistency determinations should be returned to the main mix for each subsequent addition of plasticizer until the end point is reached.

15.6 *Calculation*—Calculate the plasticizer sorption as follows:

$$\text{Plasticizer sorption, parts of DOP per 100 parts of resin by weight} = (W_0 - W_1) \times 20$$

where:

- W_0 = original weight of dropping bottle and DOP, and
- W_1 = final weight of dropping bottle and DOP.

15.7 *Report*—Report the parts of DOP per 100 parts of resin by weight for the average of duplicate determinations.

15.8 *Precision and Bias*—The precision of the test method, calculated by analysis of round-robin data from six laboratories, is as follows:

15.8.1 *Repeatability*—Coefficient of variation (average of replicates) within a laboratory of 2.1 %.

15.8.2 *Reproducibility*—Coefficient of variation (average of replicates) between laboratories of 5.0 %.

16. Dry Flow

16.1 *Summary of Test Method*—The dry flow characteristics of powdered resins bear a complex relationship to particle shape, structure, and size distribution. The flow may be measured by measuring the time for a prescribed volume of resin to flow through a standard funnel. The funnel orifice must be large enough to permit continuous flow of dry resins without

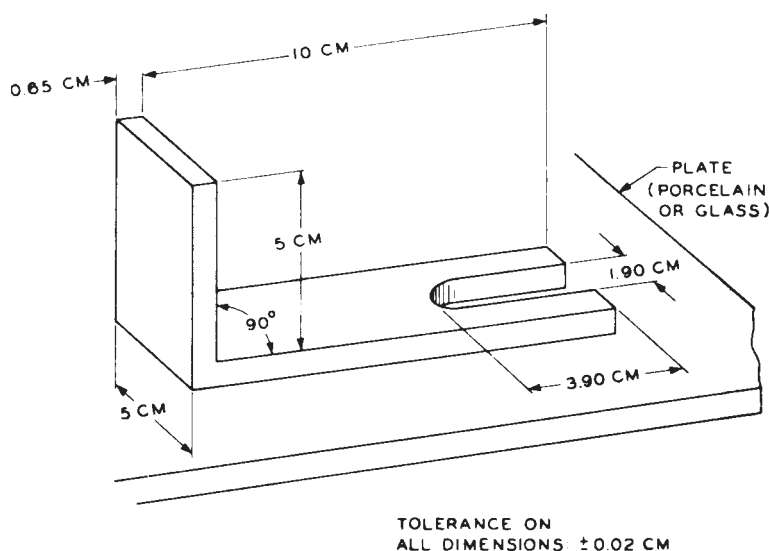

FIG. 3 Mold for Plasticizer Sorption Test

bridging. The volatile content of the resin shall be within $\pm 50\%$ of the average specified by the manufacturer (see Test Method D 3030).

NOTE 8—Resins of abnormally high or abnormally low moisture content will exhibit reduced nonuniform flow. Extremely dry resins may develop static charges that will impede flow; damp resin will coalesce.

16.2 Significance—The dry flow of a resin as determined by this test is particularly significant in conjunction with plasticizer sorption for predicting the hopper feeding characteristics of dry blended resin-plasticizer compounds.

16.3 Apparatus:

16.3.1 Metal Funnel and Cup—See the Apparatus Section in Test Methods D 1895.

16.3.2 Stop Watch.

16.4 Procedure—Put enough resin in the funnel so as to fill the cup to overflowing. Allow the resin to run into the cup. Level the resin in the cup. Close the small end of the funnel with the hand or a suitable flat strip of metal and pour the resin from the cup into the funnel. Quickly open the bottom of the funnel and start the stop watch at the same instant. Time the resin as it passes through the funnel. Repeat the procedure twice, using a different portion of resin for each determination.

16.5 Report—Report the average flow time in seconds for duplicate determinations.

16.6 Precision and Bias—The precision of the test method, calculated by analysis of the round-robin data from seven laboratories, is as follows:

16.6.1 Repeatability—Coefficient of variation (average of replicates) within a laboratory of 4.3 %.

16.6.2 Reproducibility—Coefficient of variation (average of replicates) between laboratories of 6.6 %.

17. Packaging and Package Marking

17.1 Packaging—The material shall be packaged in standard commercial containers, so constructed as to ensure acceptance by common or other carriers for safe transportation at the lowest rate to the point of delivery, unless otherwise specified in the contract or order.

17.2 Package Marking—Unless otherwise agreed upon between the purchaser and the supplier, shipping containers shall be marked with the name of the material, type and grade designation, quantity contained therein, and, as defined by the contract or order under which the shipment is made, the name of the supplier and number of the contract or order.

17.3 All packing, packaging, and marking provisions of Practice D 3892 shall apply to this specification.

18. Keywords

18.1 poly(vinyl chloride); vinyl chloride homopolymer

ASTM International takes no position respecting the validity of any patent rights asserted in connection with any item mentioned in this standard. Users of this standard are expressly advised that determination of the validity of any such patent rights, and the risk of infringement of such rights, are entirely their own responsibility.

This standard is subject to revision at any time by the responsible technical committee and must be reviewed every five years and if not revised, either reapproved or withdrawn. Your comments are invited either for revision of this standard or for additional standards and should be addressed to ASTM International Headquarters. Your comments will receive careful consideration at a meeting of the responsible technical committee, which you may attend. If you feel that your comments have not received a fair hearing you should make your views known to the ASTM Committee on Standards, at the address shown below.

This standard is copyrighted by ASTM International, 100 Barr Harbor Drive, PO Box C700, West Conshohocken, PA 19428-2959, United States. Individual reprints (single or multiple copies) of this standard may be obtained by contacting ASTM at the above address or at 610-832-9585 (phone), 610-832-9555 (fax), or service@astm.org (e-mail); or through the ASTM website (www.astm.org).