



Standard Test Methods for Apparent Density, Bulk Factor, and Pourability of Plastic Materials¹

This standard is issued under the fixed designation D 1895; the number immediately following the designation indicates the year of original adoption or, in the case of revision, the year of last revision. A number in parentheses indicates the year of last reapproval. A superscript epsilon (ϵ) indicates an editorial change since the last revision or reapproval.

This standard has been approved for use by agencies of the Department of Defense.

1. Scope

1.1 These test methods cover the measurement of apparent density, bulk factor, and where applicable, the pourability of plastic materials such as molding powders. Different procedures are given for application to the various forms of these materials that are commonly encountered, from fine powders and granules to large flakes and cut fibers.

1.2 The values stated in SI units are to be regarded as the standard. The values in parentheses are for information only.

1.3 *This standard does not purport to address all of the safety concerns, if any, associated with its use. It is the responsibility of the user of this standard to establish appropriate safety and health practices and determine the applicability of regulatory limitations prior to use.*

NOTE 1—Test Method A is equivalent to ISO Method R 60 as described in the appendix. Test Method C is identical with ISO Method R 61.

2. Referenced Documents

2.1 ASTM Standards:

D 792 Test Methods for Density and Specific Gravity (Relative Density) of Plastics by Displacement²

D 883 Terminology Relating to Plastics²

D 1505 Test Method for Density of Plastics by Density-Gradient Technique²

2.2 ISO Standards:³

R60 Determination of Apparent Density of Molding Materials that Can be Poured from a Specified Funnel

R61 Determination of Apparent Density of Molding Material that Cannot be Poured from a Specified Funnel

3. Terminology

3.1 Definitions:

¹ These test methods are under the jurisdiction of ASTM Committee D20 on Plastics and are the direct responsibility of Subcommittee D20.70 on Analytical Methods (Section D20.70.01).

Current edition approved April 10, 2003. Published June 2003. Originally approved in 1961. Last previous edition approved in 1996 as D 1895 – 96.

This edition includes the addition of an extensive ISO equivalency statement and keywords section.

² *Annual Book of ASTM Standards*, Vol 08.01.

³ Available from American National Standards Institute (ANSI), 25 W. 43rd St., 4th Floor, New York, NY 10036.

3.1.1 *apparent density*—the weight per unit volume of a material, including voids inherent in the material as tested.

3.1.1.1 The term *bulk density* is commonly used for materials such as molding powder.

3.1.2 *bulk factor*—the ratio of the volume of any given quantity of the loose plastic material to the volume of the same quantity of the material after molding or forming. The bulk factor is also equal to the ratio of the density after molding or forming to the apparent density of the material as received.

3.1.3 *pourability*—a measure of the time required for a standard quantity of material to flow through a funnel of specified dimensions.

4. Significance and Use

4.1 These test methods provide useful indexes of performance of plastic materials such as powders and granules with respect to their handling in packaging and fabrication.

4.2 Apparent density is a measure of the fluffiness of a material.

4.3 Bulk factor is a measure of volume change that may be expected in fabrication.

4.4 Pourability characterizes the handling properties of a finely divided plastic material. It is a measure of the readiness with which such materials will flow through hoppers and feed tubes and deliver uniform weights of material.

APPARENT DENSITY

Test Method A

5. Scope

5.1 Test Method A (see Note 1) covers the measurement of the apparent density of the fine granules and powders that can be poured readily through a small funnel.

6. Apparatus

6.1 *Measuring Cup*—A cylindrical cup of 100 ± 0.5 -cm capacity, having a diameter equal to half the height, for example, 39.9-mm [1.572-in.] inside diameter by 79.8-mm [3.144-in.] inside height, as shown in Fig. 1.

6.2 *Funnel*, having a 9.5-mm diameter opening at the bottom, and mounted at a height 38 mm above the measuring cup, as shown in Fig. 1.

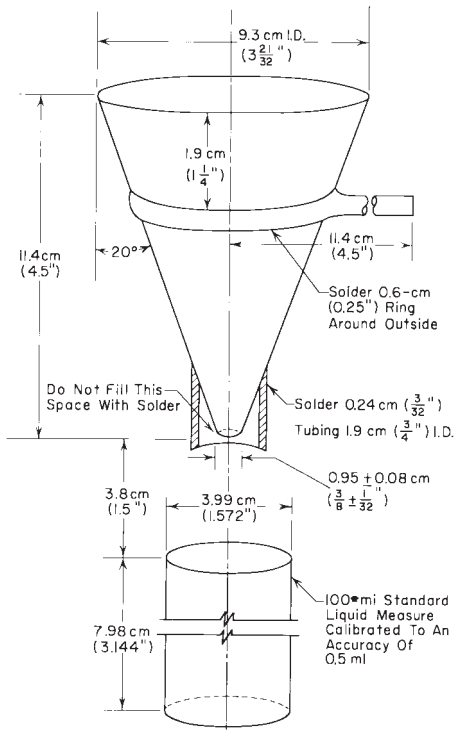

FIG. 1 Apparatus for Apparent Density Test, Method A

7. Procedure

7.1 With the apparatus assembled as shown in Fig. 1, close the small end of the funnel with the hand or with a suitable flat strip and pour a $115 \pm 5\text{-cm}^3$ sample into the funnel. Open the bottom of the funnel quickly and allow the material to flow freely into the cup. If caking occurs in the funnel, the material may be loosened with a small glass rod.

7.2 After all the material has passed through the funnel, immediately scrape off the excess on the top of the cup with a straightedge without shaking the cup. Weigh the material in the cup to the nearest 0.1 g. Calculate the weight in grams of 1 cm^3 of the material.

NOTE 2—To convert grams per cubic centimetre to ounces per cubic inch, multiply by 0.578. To convert to grams per cubic inch multiply by 16.39. To convert grams per cubic centimetre to pounds per cubic foot, multiply by 62.43.

NOTE 3—Apparent density figures are not comparable except on materials having the same specific gravity after molding or forming.

7.3 Very fine materials that will bridge and not flow through the funnel may be poured lightly from a paper held approximately 38 mm [1.5 in.] above the opening of the measuring cup.

Test Method B

8. Scope

8.1 Test Method B covers the measurement of the apparent density of coarse, granular materials, including dice and pellets, that either cannot be poured or that pour with difficulty through the funnel described in Test Method A.

9. Apparatus

9.1 *Measuring Cup*—A cylindrical cup of 400-cm^3 capacity, as shown in Fig. 2.

9.2 *Funnel*, having a 25.4-mm [1-in.] diameter opening at the bottom, and mounted at a height 38 mm [1.5 in.] above the measuring cup, as shown in Fig. 2.

NOTE 4—Finely divided powders may collect electrostatic charges which, if present at the time of measurement, may result in variable apparent density values. Carbon black is a material that may be premixed with the sample at concentrations of 0.05 to 0.2 weight percent to reduce this variability (Superba Black with a bulk density of about 8 lb/ft³ has been found satisfactory for some materials).

10. Procedure

10.1 With the apparatus assembled as shown in Fig. 2, close the small end of the funnel with the hand or with a suitable flat strip and pour a $500 \pm 20\text{-cm}^3$ sample into the funnel. Open the bottom of the funnel quickly and allow the material to flow freely into the cup.

NOTE 5—The funnel described in Test Method B is also used for more finely divided powders such as vinyl resins. While these powders usually will pour through this funnel, they may bridge in the 400-cm^3 cup shown in Fig. 2. To avoid this, the 100-cm^3 cup shown in Fig. 1 may be substituted, and the sample reduced to $115 \pm 5\text{ cm}^3$.

10.2 After all the material has passed through the funnel, immediately scrape off the excess on the top of the cup with a straightedge without shaking the cup. Weigh the material in the cup to the nearest 0.1 g; then calculate the weight in grams of 1 cm^3 of the material. Make three determinations of the apparent density on each sample and average the results (Note 2).

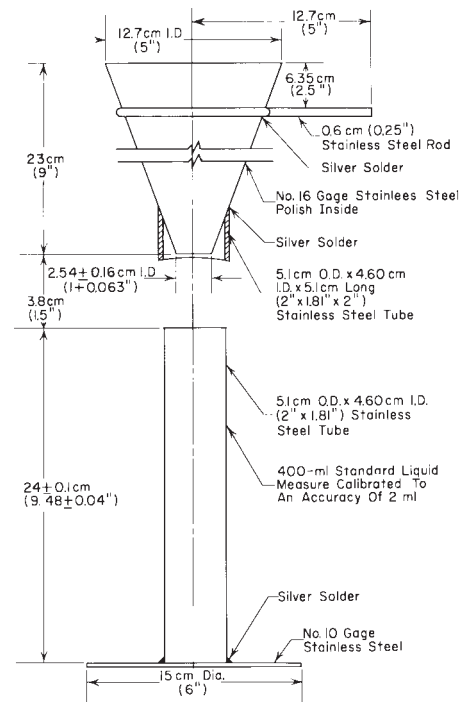

FIG. 2 Apparatus for Apparent Density Test, Method B

11. Scope

11.1 Test Method C (see Note 1) covers the measurement of the apparent density of materials supplied in the form of coarse flakes, chips, cut fibers, or strands. Such materials cannot be poured through the funnels described in Test Methods A and B. Also, since they ordinarily are very bulky when loosely poured and since they usually are compressible to a lesser bulk, even by hand, a measure of their density under a small load is appropriate and useful.

12. Apparatus

12.1 *Measuring Cylinder*—A cylinder of 1000-cm³ capacity, as shown in Fig. 3.

12.2 *Weight Plunger*—A cylinder closed at one end and having an outside diameter slightly smaller than the inside diameter of the measuring cylinder, as shown in Fig. 3. The plunger shall have a scale cut on the outside surface, graduated in intervals of 1 mm.

13. Procedure

13.1 Place the measuring cylinder on a piece of paper. Loosely drop 60 ± 0.2 g of the material to be tested into the measuring cylinder from a height approximately that of the cylinder, taking care to lose none of the material and to drop it as uniformly as practicable. Before applying the weight, level the material in the measuring cylinder. Measure the height of the loose material in centimetres and identify this measurement as *H*₁.

13.2 Fill the weight plunger with lead shot to obtain a total weight of 2300 ± 20 g [5.07 ± 0.04 lb], including the plunger. Lower this weight gradually into the measuring cylinder until it is entirely supported by the material. Allow the weight to settle for 1 min and take the reading from the scale to the

nearest 0.1 cm. This reading will give directly in centimetres the height, *H*₂, of the material.

14. Precision and Bias

14.1 Table 1 is based on a round-robin test conducted in 1987–88, involving eight materials, tested by six laboratories. Each of the materials were commercial materials and were distributed to the testing laboratories on an “as received” bias. Each test result was based on three individual determinations, and was obtained either by Test Method A or B, dependent upon equipment availability in the individual laboratory. Test Method C was not evaluated. Insufficient data were collected for the evaluation of bulk factor and pourability because of the inherent properties of the tested materials, and limitations in the equipment available to the laboratories involved in the interlaboratory test.

NOTE 6—Specific materials are:

- A—poly(propylene)
- B—cellulose acetate
- C—poly(ethylene)
- D—nylon polyamide
- E—polyacetal
- F—poly(vinylidene chloride)
- G—poly(vinyl chloride)
- H—polyester (PETE)

14.2 In Table 1, for the materials indicated and for mean values that were derived from triplicate determinations:

14.2.1 *S*_w is the within-laboratory standard deviation of the mean and *I*_w = 2.83 *S*_w.

14.2.2 *S*_R is the between-laboratory standard deviation of the mean and *I*_R = 2.83 *S*_R.

14.2.3 *V*_w and *V*_R are the relative standard deviations for the within-laboratory and between-laboratory components in percentage of the relevant mean.

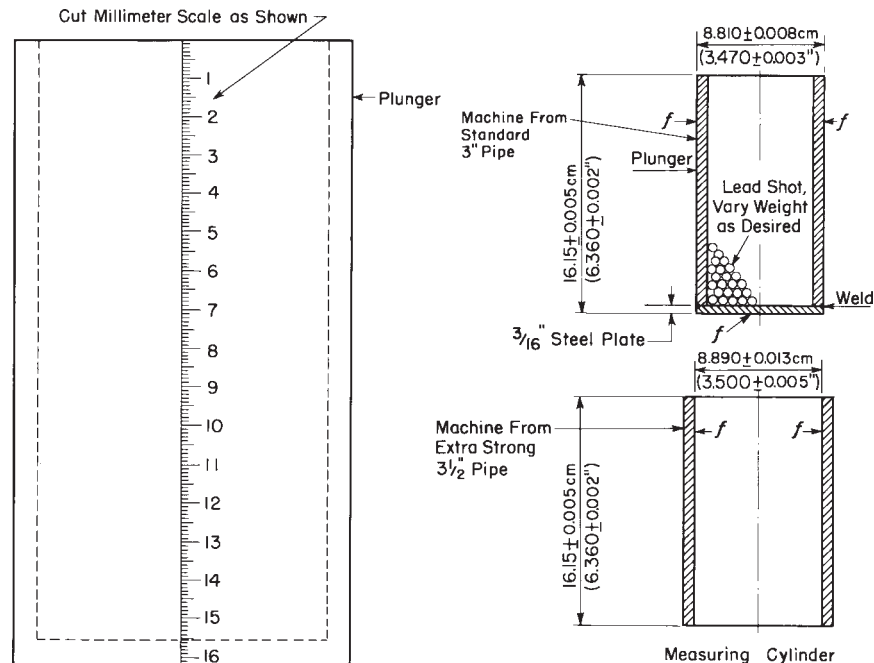

FIG. 3 Apparatus for Apparent Density Test, Method C

TABLE 1 Precision and Bias Data^A

Material	Average	S _r	S _R	I _r	I _R	V _r	V _R
A	0.5372	0.0023	0.0256	0.0065	0.0724	0.43	4.77
B	0.7342	0.0026	0.0377	0.0074	0.1067	0.35	5.14
C	0.6191	0.0026	0.0230	0.0074	0.0651	0.42	3.71
D	0.7314	0.0029	0.0342	0.0082	0.0968	0.39	4.67
E	0.8766	0.0054	0.0302	0.0153	0.0855	0.62	3.44
F	0.7819	0.0009	0.0165	0.0025	0.0467	0.11	2.11
G	0.6092	0.0018	0.0112	0.0051	0.0317	0.30	1.83
H	0.7975	0.0062	0.0350	0.0175	0.0991	0.77	4.39

^A Supporting data are available from ASTM Headquarters. Request RR:D20-1161.

14.3 *Bias*—Since no absolute test method exists for comparison, no bias statement can be presented for this test method.

15. Calculation

15.1 Calculate the apparent density of the material before and after application of the load as follows, making separate calculations for both H_1 , and H_2 :

$$V = H \times A \quad (1)$$

$$\text{Apparent density} = W/V \quad (1)$$

where:

V = volume occupied by the material in the measuring cylinder, cm³,

H = height of the material in the measuring cylinder, cm,

A = cross-sectional area of the measuring cylinder, (61.89 cm²), and

W = weight of the material in the cylinder (60 g).

15.2 Make three determinations of the apparent density on each sample and average these results separately.

16. Report

16.1 Report each value of the apparent density and of the average density, both before and after loading.

BULK FACTOR

17. Procedure

17.1 *Apparent Density*—Measure the apparent density of the material in accordance with the applicable test method as defined in Sections 5-15.

17.2 *Density After Molding or Forming*—Measure the density of the molded or formed plastic material in accordance with either Test Method D 1505, or Method A of Test Methods D 792, on two or more samples formed of the material under examination. When the latter method is used, the average specific gravity, in general, shall be assumed to be numerically equal to the average density in grams per cubic centimetre. If the shape of the formed specimen is such that its volume may be readily and accurately calculated from its dimensions, the density may be determined by dividing the weight of the specimen by its volume.

18. Calculation

18.1 Calculate the bulk factor of the plastic material as follows:

$$\text{Bulk factor} = D_2/D_1 \quad (2)$$

where:

D_2 = average density of the molded or formed specimen, and

D_1 = average apparent density of the plastic material prior to forming.

19. Report

19.1 Report the following information:

19.1.1 Average apparent density of the plastic material and the method employed,

19.1.2 Average density of the molded or formed specimen, and

19.1.3 Bulk factors (Note 7 and Note 8) calculated from them.

NOTE 7—Because bulk factor is a dimensionless ratio, it permits ranking of plastic materials, with respect to volume change upon fabrication, regardless of their molded or formed density (or specific gravity).

NOTE 8—For measurements made in accordance with Test Method C, bulk factor before and after loading shall be reported. These shall be clearly identified.

POURABILITY

20. Apparatus

20.1 The apparatus shall consist of the funnel described in Test Method A (6.2 and Fig. 1), mounted as shown, and either a stopwatch or an electric timer of comparable accuracy.

NOTE 9—Pourability may be measured with the funnel described in Test Method B (9.2); however, the flow of material through this funnel is frequently too rapid to yield meaningful results. Test Method C does not permit measurement of pourability.

21. Procedure

21.1 Take a sample of the plastic material weighing, in grams, 100 times its specific gravity (or density) after molding or forming. Work this sample on a paper until there is no tendency for the material to pack or cake. With the apparatus assembled as shown in Fig. 1, close the small end of the funnel with the hand or with a suitable flat strip and pour the sample lightly into the funnel, avoiding any tendency to pack it. Then quickly open the bottom of the funnel and start the stopwatch or timer at the same instant. Allow the material to run from the funnel as freely as it will, and stop the watch or timer at the instant the last of it leaves the funnel.

22. Report

22.1 Report the time in seconds required for the funnel to discharge, to the nearest 0.2 s; or, if so found, that the material will not run through the funnel.

23. Keywords

23.1 apparent density; bulk factor; pourability

APPENDIX

(Nonmandatory Information)

X1. RELATION WITH ISO MATERIAL R60, DETERMINATION OF APPARENT DENSITY OF MOLDING MATERIAL THAT CAN BE POURED FROM A SPECIFIED FUNNEL

X1.1 ISO Method R 60 differs from Test Method A in the following respects:

X1.1.1 *Funnel* as shown in Fig. X1.1.

X1.1.2 *Measuring Cylinder*, which differs only in that the internal diameter is 45 ± 5 mm [1.77 ± 0.20 in.].

X1.1.3 Mounting of the funnel is such that its lower orifice is 20 to 30 mm [0.79 to 1.18 in.] above the measuring cylinder.

X1.2 Test Method A and ISO Method R 60 have been found to give values that differ by -0.01 to $+0.03$ apparent density units (g/cm^3) based on the average of five tests for each of three materials.

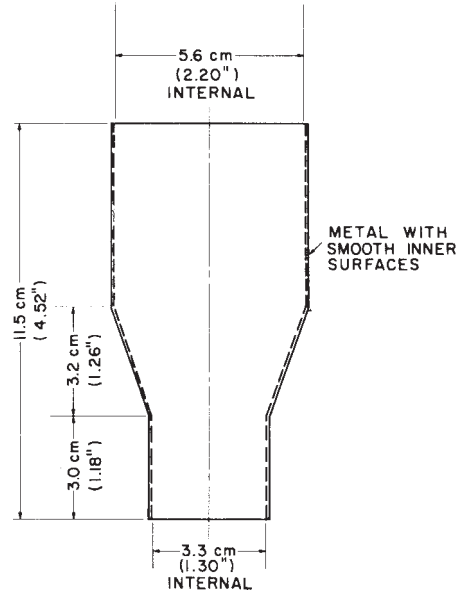

FIG. X1.1 Funnel for ISO Method R 60

ASTM International takes no position respecting the validity of any patent rights asserted in connection with any item mentioned in this standard. Users of this standard are expressly advised that determination of the validity of any such patent rights, and the risk of infringement of such rights, are entirely their own responsibility.

This standard is subject to revision at any time by the responsible technical committee and must be reviewed every five years and if not revised, either reapproved or withdrawn. Your comments are invited either for revision of this standard or for additional standards and should be addressed to ASTM International Headquarters. Your comments will receive careful consideration at a meeting of the responsible technical committee, which you may attend. If you feel that your comments have not received a fair hearing you should make your views known to the ASTM Committee on Standards, at the address shown below.

This standard is copyrighted by ASTM International, 100 Barr Harbor Drive, PO Box C700, West Conshohocken, PA 19428-2959, United States. Individual reprints (single or multiple copies) of this standard may be obtained by contacting ASTM at the above address or at 610-832-9585 (phone), 610-832-9555 (fax), or service@astm.org (e-mail); or through the ASTM website (www.astm.org).