



Designation: D 2116 – 97

## Standard Specification for FEP-Fluorocarbon Molding and Extrusion Materials<sup>1</sup>

This standard is issued under the fixed designation D 2116; the number immediately following the designation indicates the year of original adoption or, in the case of revision, the year of last revision. A number in parentheses indicates the year of last reapproval. A superscript epsilon ( $\epsilon$ ) indicates an editorial change since the last revision or reapproval.

*This standard has been approved for use by agencies of the Department of Defense.*

### 1. Scope \*

1.1 This specification covers melt processable molding and extrusion materials of FEP-fluorocarbon resin. This specification does not cover recycled FEP materials. These FEP resins are copolymers of tetrafluoroethylene and hexafluoropropylene or modified FEP-fluorocarbon resins containing not more than 2 % by weight of other fluoromonomers.

1.2 The values stated in SI units as detailed in Practice E 380 are to be regarded as the standard and the principles of Practice E 380 incorporated herein.

NOTE 1—Although this specification and ISO 12086-1 and ISO 12086-2 differ in approach or detail, data obtained using either are technically equivalent.

1.3 The following precautionary caveat pertains only to the test methods portion, Section 11, of this specification. *This standard does not purport to address all of the safety concerns, if any, associated with its use. It is the responsibility of the user of this standard to establish appropriate safety and health practices and determine the applicability of regulatory limitations prior to use.*

### 2. Referenced Documents

#### 2.1 ASTM Standards:

- D 150 Test Methods for A-C Loss Characteristics and Permittivity (Dielectric Constant) of Solid Electrical Insulating Materials<sup>2</sup>
- D 618 Practice for Conditioning Plastics for Testing<sup>3</sup>
- D 638 Test Method for Tensile Properties of Plastics<sup>3</sup>
- D 792 Test Methods for Density and Specific Gravity (Relative Density) of Plastics by Displacement<sup>3</sup>
- D 883 Terminology Relating to Plastics<sup>3</sup>
- D 1238 Test Method for Flow Rates of Thermoplastics by Extrusion Plastometer<sup>3</sup>
- D 1600 Terminology for Abbreviated Terms Relating to Plastics<sup>3</sup>
- D 1898 Practice for Sampling of Plastics<sup>3</sup>

<sup>1</sup> This specification is under the jurisdiction of ASTM Committee D-20 on Plastics and is the direct responsibility of Subcommittee D20.15 on Thermoplastic Materials (Section D20.15.12).

Current edition approved Nov. 10, 1997. Published April 1998. Originally published as D 2116 – 62 T. Last previous edition D 2116 – 96.

<sup>2</sup> Annual Book of ASTM Standards, Vol 10.01.

<sup>3</sup> Annual Book of ASTM Standards, Vol 08.01.

D 3295 Specification for PTFE Tubing<sup>4</sup>

D 3418 Test Method for Transition Temperatures of Polymers by Thermal Analysis<sup>4</sup>

D 3892 Practice for Packaging/Packing of Plastics<sup>4</sup>

E 380 Practice for Use of the International System of Units (SI) (the Modernized Metric System)<sup>5</sup>

E 691 Practice for Conducting an Interlaboratory Study to Determine the Precision of a Test Method<sup>5</sup>

#### 2.2 ISO Standards:<sup>6</sup>

ISO 12086-1:1995 Plastics—Fluoropolymer Dispersions and Moulding and Extrusion Materials—Part 1

ISO 12086-2:1995 Plastics—Fluoropolymer Dispersions and Moulding and Extrusion Materials—Part 2

### 3. Terminology

#### 3.1 Definitions:

3.1.1 *General*—The definitions given in Terminology D 883 are applicable to this specification.

#### 3.2 Abbreviated Terms:

3.2.1 *General*—The abbreviated terms given in Terminology D 1600 are applicable to this specification.

### 4. Classification

4.1 This specification covers four types of FEP-fluorocarbon resin supplied in pellet form classified according to their melt flow rate.

4.2 A one-line system may be used to specify materials covered by this specification. The system uses predefined cells to refer to specific aspects of this specification, illustrated as follows:

Specification			
Standard Number Block	Type		Special notes
_____	:	:	:
_____	:	:	:

Example: Specification D 2116 – 95, I

For this example, the line callout would be Specification D 2116 – 95,I and would specify an FEP-fluorocarbon resin

<sup>4</sup> Annual Book of ASTM Standards, Vol 08.02.

<sup>5</sup> Annual Book of ASTM Standards, Vol 14.02.

<sup>6</sup> Available from American National Standards Institute, 11 W. 42nd St., 13th Floor, New York, NY 10036.

**\*A Summary of Changes section appears at the end of this standard.**



that has all of the properties listed for that type, grade, and class in the appropriate specified properties or tables, or both, in the specification identified. A comma is used as the separator between the standard number and the type.<sup>7</sup> A provision for special notes is included so that other information can be provided when required. An example would be in Specification D 3295 where dimensions and tolerances are specified for each AWG size within type and class. When special notes are used, they should be preceded by a comma.

## 5. General Requirements

5.1 The materials shall be of uniform composition and so prepared as to conform to the requirements of this specification.

5.2 The material described in this specification shall be free of foreign matter to such a contamination level as may be agreed upon between the purchaser and the seller.

## 6. Detail Requirements

6.1 The average test result of the lot shall conform to the requirements prescribed in Table 1 and Table 2 when tested by

**TABLE 1 Detail Requirements for Test on Molding Materials**

	Type I	Type II	Type III	Type IV
Melt flow rate, g/10 min:				
Load, 5000 g:				
Min	4.0	>12.0	0.8	2.0
Max	12.0	...	2.0	3.9

**TABLE 2 Detail Requirements for Molded Test Specimens**

	Type I	Type II	Type III	Type IV
Specific gravity 23/23°C (73/73°F)				
Min	2.12	2.12	2.12	2.12
Max	2.17	2.17	2.17	2.17
Melting point, °C	260 ± 20	260 ± 20	260 ± 20	260 ± 20
Tensile strength, 23°C (73°F), min:				
MPa	17.3	14.5	20.7	18.7
psi	2500	2100	3000	2700
Elongation, 23°C (73°F), min, %	275	240	275	275
Dielectric constant, max:				
At 10 <sup>3</sup> Hz	2.15	2.15	2.15	2.15
At 10 <sup>6</sup> Hz	2.15	2.15	2.15	2.15
Dissipation factor, max:				
At 10 <sup>3</sup> Hz	0.0003	0.0003	0.0003	0.0003
At 10 <sup>6</sup> Hz	0.0007	0.0009	0.0007	0.0007

the procedures specified herein. Table 2 lists those tests requiring a specimen molded as described in Section 8.

## 7. Sampling

7.1 Unless otherwise agreed upon between the purchaser and the seller the materials shall be sampled in accordance with Practice D 1898. Adequate statistical sampling shall be considered an acceptable alternative.

## 8. Test Specimens

8.1 Prepare a molded sheet 1.5 ± 0.3 mm (0.060 ± 0.010

in.) thick. Use a picture-frame-type chase having a suitable blanked-out section and thickness to produce the desired sheet. Use clean aluminum foil, 0.13 to 0.18 mm (0.005 to 0.007 in.) thick, in contact with the resin. A high-temperature mold release agent may be sprayed on the aluminum foil to help prevent the foil from sticking to the sheet. Use steel molding plates at least 1.0 mm (0.040 in.) thick and of an area adequate to cover the chase.

8.2 Lay down and smoothly cover one plate with a sheet of aluminum foil. Place the mold chase on top of this assembly. Place within the mold chase sufficient molding material to produce the required sheet in such a manner that the polymer charge is a mound in the middle of the chase. Place a second sheet of aluminum foil on top of the granules and add the top mold plate. Place the assembly in a compression molding press having platens that have been heated to 372 ± 5°C (702 ± 9°F).

8.3 Bring the platens to incipient contact with the mold assembly. Hold for 2 to 4 min without pressure. Apply approximately 1 MPa (145 psi) and hold for 1 to 1.5 min. Then apply 2 to 4 MPa (290 to 580 psi) and hold for 1 to 1.5 min. Maintain the press at 372 ± 5°C (702 ± 9°F) during these steps. Remove the assembly from the press and place between two 20 ± 7-mm (0.75 ± 0.25-in.) steel plates whose temperature is less than 40°C (104°F).

8.4 When the sheet is cool enough to touch (about 50 to 60°C (122 to 140°F)), remove aluminum foil from the sheet. (If the sheet is allowed to cool to room temperature, the aluminum

foil cannot be pulled free.)

## 9. Conditioning

9.1 For tests of specific gravity and tensile properties, condition the molded test specimens in accordance with Procedure A of Practice D 618 for a period of at least 4 h prior to test. The other tests require no conditioning.

9.2 Conduct tests at the Standard Laboratory Temperature of 23 ± 2°C (73.4 ± 3.6°F) for determination of specific gravity and tensile properties only. Since this resin does not absorb water, the maintenance of constant humidity during testing is not necessary. Conduct tests for melt flow rate and melting point under ordinary laboratory conditions.

<sup>7</sup> See the ASTM *Form and Style Manual*, available from ASTM Headquarters.



## 10. Packaging and Marking

10.1 *Packaging*—The resin pellets shall be packaged in standard commercial containers so constructed as to ensure acceptance by common or other carriers for safe transportation to the point of delivery, unless otherwise specified in the contract or order.

10.2 *Marking*—Shipping containers shall be marked with the name of the material, type, and quantity contained therein.

10.3 All packing, packaging, and marking provisions of Practice D 3892 shall apply to this specification.

## 11. Test Methods

### 11.1 Melt Flow Rate:

11.1.1 *Principle of Test Method*—The melt flow rate is determined at  $372 \pm 1^\circ\text{C}$  using Procedure A or B described in Test Method D 1238. The extrusion plastometer to be used is described in Test Method D 1238 modified by use of corrosion resistant alloy for the barrel lining, orifice, piston tip, and orifice securing device.<sup>8</sup> The sample may be pellets or pieces of approximately the same suitable size cut from molded or extruded forms. Strips about 6-mm wide by 76 mm long (0.25 by 3 in.) may be conveniently handled. Refer to Table 2 or Table 3 of Test Method D 1238 for the amount of charge which should be adjusted accordingly with melt density of FEP being used. Usually the charge amount is 5 to 15 g. Flow rate is measured using a load of 5000 g. Collect five successive cuts for the manual method.

11.2 *Specific Gravity*—Determine the specific gravity on a specimen approximately 25.4 by 38 mm (1 by 1.5 in.) blanked or cut from the molded plaque (Section 8) in accordance with the procedures described in Test Methods D 792. Add 2 drops of a wetting agent to the water in order to reduce the surface tension and ensure complete wetting of the specimen.

### 11.3 Melting Point:

11.3.1 *Melting Characteristics by Thermal Analysis*—Use differential scanning calorimetry (DSC) as described in Test Method D 3418 for this determination. For specification purposes, the test shall be run on a  $10 \pm 2$ -mg specimen cut from a pellet of the resin as sold or received. The heating rate shall be  $10 \pm 1^\circ\text{C}$  ( $18 \pm 1.8^\circ\text{F}$ )/min. Two peaks during the initial melting test are observed occasionally. In this case, the peak temperatures shall be reported as  $T_1$  for the lower temperature and  $T_u$  for the upper temperature. The peak temperature of the peak largest in height shall be reported as the melting point if a single value is required. If a peak temperature is difficult to discern from the curves, that is, if the peak is rounded rather than pointed, straight lines shall be drawn tangent to the sides of the peak. The temperature corresponding to the point where these lines intersect beyond the peak should be taken as the peak temperature.

11.4 *Tensile Properties*—Cut five bars with the microtensile die shown in Fig. 1. The die shall be of the steel rule or solid metal type of curvature of  $5 \pm 0.5$  mm ( $0.2 \pm 0.02$  in.). Average the test results. Determine the tensile properties in

accordance with the procedures described in Test Method D 638, except that the specimens used shall be as detailed in Section 8, the initial jaw separation shall be  $22.2 \pm 0.13$  mm ( $0.875 \pm 0.005$  in.), and the speed of testing shall be  $50 \pm 5$  mm/min ( $2 \pm 0.2$  in./min). Clamp the specimen with essentially equal lengths in each jaw. Determine the elongation from the chart, expressing it as a percentage of the initial jaw separation.<sup>8</sup>

NOTE 2—In determining elongation from the chart, drop a perpendicular from the break point to the time axis. Measure the distance along the time axis from the foot of this perpendicular to the beginning of the load-time curve. Then,

$$\text{Elongation, \%} = 100d/(22.2 \text{ or } 0.875)m \quad (1)$$

where:

- $d$  = distance on chart, mm (in.),
- $m$  = chart speed magnification,
- = chart speed/crosshead speed (both in same units), and
- 22.2 = factor when  $d$  is in millimetres, or
- 0.875 = factor when  $d$  is in inches.

In making the test for tensile properties a full-scale load of 22.5 kg (50 lb) has been found suitable. If specimens break quickly, it may be necessary to increase the chart speed so that each curve covers at least 51 mm (2 in.) on the time axis of the chart.

### 11.5 Precision and Bias:<sup>9</sup>

11.5.1 *Precision*—Table 3 is based on a round robin conducted in 1985–1986 in accordance with Practice E 691, involving seven materials tested by six laboratories. For each material, the sheeting from which the test specimens were to be cut was obtained from one source. Using a steel rule die, one set of test specimens for each laboratory was cut by one of the laboratories. Sheeting and a duplicate die were furnished each participating laboratory and used to cut a second set of test specimens. Each test result was the average of five individual determinations. Each laboratory obtained four test results on each material, two test results each on the specimens furnished and two on the specimens cut by the laboratory doing the testing.

11.5.1.1 The properties used in the analysis are tensile strength and elongation at break.

NOTE 3—**Caution:** The following explanations of  $I_r$  and  $I_R$  (11.5.1.4–11.5.1.6) are intended only to present a meaningful way of considering the approximate precision of this test method. The data in Table 3 should not be applied rigorously to acceptance or rejection of material, as those data are specific to the round robin and may not be representative of other lots, conditions, materials, or laboratories.

11.5.1.2 Users of this test method should apply the principles outlined in Practice E 691 to generate data specific to their laboratory and materials, or between specific laboratories. The principles of 11.5.1.4–11.5.1.6 would then be valid for such data.

11.5.1.3 *Concept of  $I_r$  and  $I_R$* —If  $CV_r$  and  $CV_R$  have been calculated from a large enough body of data, and for test results:

11.5.1.4  *$I_r$ : Repeatability*—In comparing two test results for the same material, obtained by the same operator using the

<sup>8</sup> “Stellite” Grade No. 19, Haynes-Stellite Co., Kokomo, IN and “Duranickel” No. 301, International Nickel Co., 67 Wall St., New York, NY 10005, have been found resistant to fluorocarbon resins.

<sup>9</sup> Supporting data are available from ASTM Headquarters.

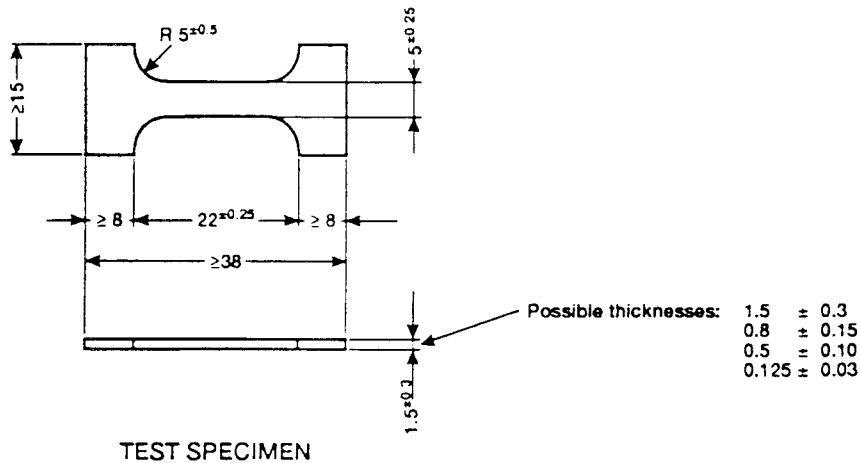
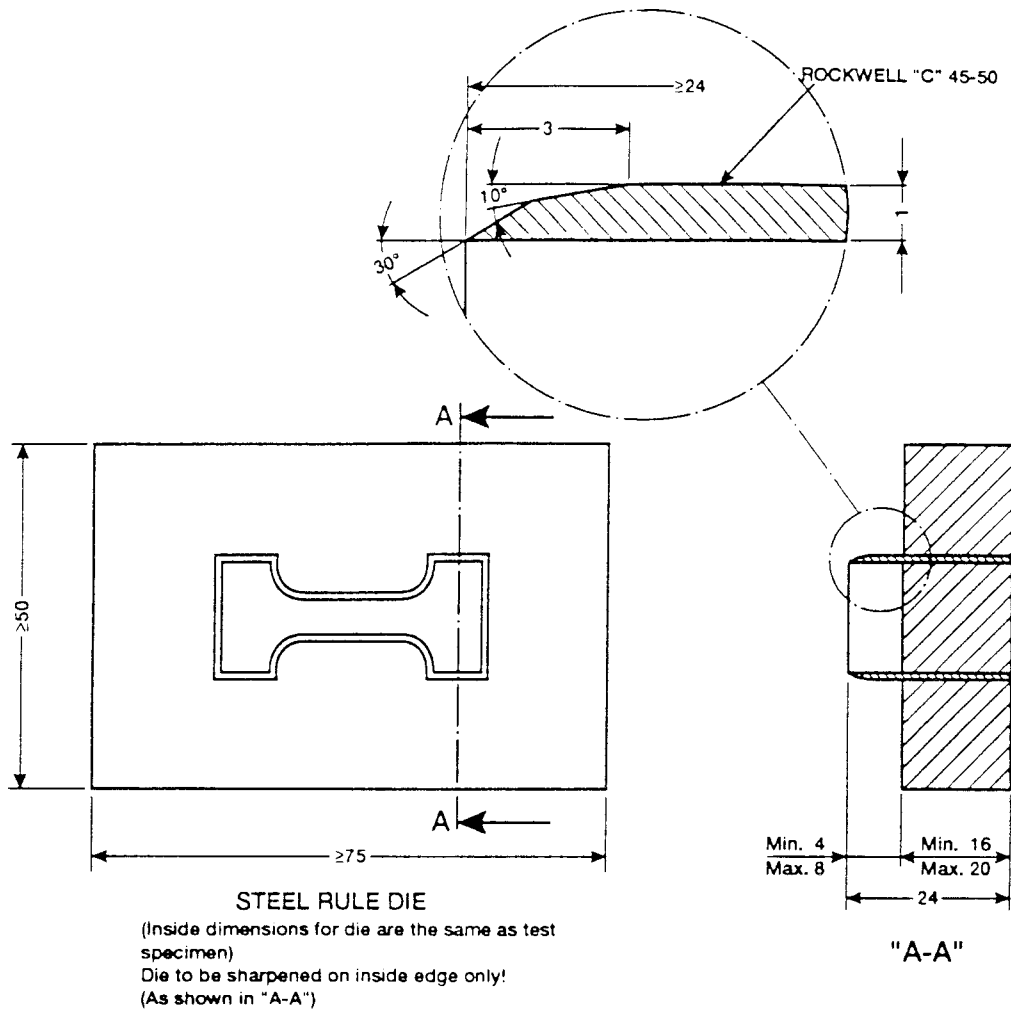

NOTE 1—All Dimensions are in millimetres.

FIG. 1 Microtensile Die

same equipment on the same day, the two test results should be judged not equivalent if they differ by more than the  $I_r$  value for that material.

11.5.1.5  $I_R$ : *Reproducibility*—In comparing two test results for the same material, obtained by different operators using

different equipment on different days, the two test results should be judged not equivalent if they differ by more than the  $I_R$  value for that material.

11.5.1.6 Any judgment in accordance with 11.5.1.4 and



**TABLE 3 Precision Summary, Tensile Strength and Elongation at Break**

NOTE 1— $I_r = 2.8 \times CV_r$ ;  $I_R = 2.8 CR_R$ .

Material	Mean, psi	Tensile Strength			
		$CV_r$ , %	$CV_{Rr}$ , %	$I_r$ , %	$I_{Rr}$ , %
FEP	4144	2.98	7.98	8.34	22.34
Material	Mean, %E	Percentage Elongation at Break			
		$CV_r$ , %	$CV_{Rr}$ , %	$I_r$ , %	$I_{Rr}$ , %
FEP	319	2.21	7.60	6.19	21.28

11.5.1.5 would have an approximate 95 % (0.95) probability of being correct.

11.5.2 *Bias*—Bias is systematic error that contributes to the difference between a test result and a true (or reference) value. There are no recognized standards on which to base an estimate of bias for this test procedure.

11.6 *Dielectric Constant*—Determine dielectric constant and dissipation factor in accordance with Test Methods D 150.

## 12. Number of Tests

12.1 One set of test specimens as prescribed in Section 8 shall be considered sufficient for testing each sample. The average result of the samples tested shall conform to the requirements of this specification.

## 13. Certification and Inspection

13.1 Certification and inspection of the material supplied under this specification shall be for conformance to the requirements specified herein.

13.1.1 *Certification*—When requested, the supplier shall furnish certification that the material was manufactured, sampled, tested, and inspected in accordance with this specification and has been found to meet the requirements.

13.1.2 *Lot-Acceptance Inspection*—Lot-acceptance inspection shall be the basis on which acceptance or rejection of the lot is made. The lot-acceptance inspection shall consist of the melt flow rate test.

13.1.3 *Periodic-Check Inspection*—The periodic-check inspection shall consist of the tests specified for all requirements of the material under this specification.

13.1.4 *Reports*—When specified in the purchase order or contract, a report of the test results shall be furnished. The report shall consist of results of the lot-acceptance inspection for the shipment.

## 14. Keywords

14.1 extrusion material; FEP fluorocarbon polymer; fluorocarbon polymer; fluoropolymers; melt-processible fluorocarbon polymer; recycled; tetrafluoroethylene copolymers

## SUMMARY OF CHANGES

Committee D-20 has identified the location of selected changes to this specification since the last issue that may impact the use of this specification:

*D 2116-97:*

(1) In 1.1, "... 1 % by weight of other fluoromonomers," is changed to read, "... 2 % by weight of other fluoromonomers."

*ASTM International takes no position respecting the validity of any patent rights asserted in connection with any item mentioned in this standard. Users of this standard are expressly advised that determination of the validity of any such patent rights, and the risk of infringement of such rights, are entirely their own responsibility.*

*This standard is subject to revision at any time by the responsible technical committee and must be reviewed every five years and if not revised, either reapproved or withdrawn. Your comments are invited either for revision of this standard or for additional standards and should be addressed to ASTM International Headquarters. Your comments will receive careful consideration at a meeting of the responsible technical committee, which you may attend. If you feel that your comments have not received a fair hearing you should make your views known to the ASTM Committee on Standards, at the address shown below.*

*This standard is copyrighted by ASTM International, 100 Barr Harbor Drive, PO Box C700, West Conshohocken, PA 19428-2959, United States. Individual reprints (single or multiple copies) of this standard may be obtained by contacting ASTM at the above address or at 610-832-9585 (phone), 610-832-9555 (fax), or service@astm.org (e-mail); or through the ASTM website (www.astm.org).*