



Designation: D 2343 – 9503

Standard Test Method for Tensile Properties of Glass Fiber Strands, Yarns, and Rovings Used in Reinforced Plastics¹

This standard is issued under the fixed designation D 2343; the number immediately following the designation indicates the year of original adoption or, in the case of revision, the year of last revision. A number in parentheses indicates the year of last reapproval. A superscript epsilon (ϵ) indicates an editorial change since the last revision or reapproval.

1. Scope*

1.1 This test method covers the determination of the comparative tensile properties of glass fiber strands, yarns, and rovings in the form of ~~straight standard impregnated rod~~ test specimens when tested under defined conditions of pretreatment, temperature, humidity, and tension testing machine speed. This test method is applicable to continuous filament, glass fiber materials that have been coated with a resin compatible sizing. This method is intended for use in quality control and R & D, and should not be used to develop composites design data.

NOTE 1—~~This method is no known ISO technically equivalent to this test method described in ISO 9163.~~

NOTE 2—~~This test method was originally developed as a quality control test for glass fiber. It~~ 2—Prime consideration should not be used given to develop composites design data. Consult Test Method D 638, Test Method D 3039/D 3039M, or the materials specification use of a polymeric binder that produces specimens that yield the highest consistent values for the glass fiber material under test. Tensile properties may vary with specimen preparation, resin impregnation system, and speed and environment of composite design properties. testing. Consequently, where precise comparative results are desired, these factors must be carefully controlled.

1.2 The values stated in SI units are to be regarded as the standard. The values given in parentheses are for information only.

NOTE 3—Prime consideration should be given to the use of a polymeric binder that produces specimens that yield the highest consistent values for the glass fiber material under test. Tensile properties may vary with specimen preparation, resin impregnation system, and speed and environment of testing. Consequently, where precise comparative results are desired, these factors must be carefully controlled.

1.3 *This standard does not purport to address all of the safety concerns, if any, associated with its use. It is the responsibility of the user of this standard to establish appropriate safety and health practices and determine the applicability of regulatory limitations prior to use.*

¹ This test method is under the jurisdiction of ASTM Committee D-20 on Plastics and is the direct responsibility of Subcommittee D20.18 on Reinforced Thermosetting Plastics.

Current edition approved Feb. 15, 1995; November 1, 2003. Published April 1995; January 2004. Originally published as D 2343 – 65 T; approved in 1965. Last previous edition D 2343 – 67 (1985).

Changes incorporated since the last revision of this test method are designed to improve reproducibility by giving more specific instructions on the sample preparation procedures; approved in 1995 as D 2343 - 95.

*A Summary of Changes section appears at the end of this standard.

2. Referenced Documents

2.1 *ASTM Standards:*²

D 618 Practice for Conditioning Plastics and Electrical Insulating Materials for Testing

D 638 Test Method for Tensile Properties of Plastics² 883 Terminology Relating to Plastics

² For referenced ASTM standards, visit the ASTM website, www.astm.org, or contact ASTM Customer Service at service@astm.org. For Annual Book of ASTM Standards, Vol 08.01, volume information, refer to the standard's Document Summary page on the ASTM website.

D 3039/D 3039M Test Method for Tensile Properties of ~~Fiber-Resin Composites~~³ Polymer Matrix Composite Material
 D 5083 Test Method for Tensile Properties of Reinforced Thermosetting Plastics Using Straight-Sided Specimens
 E 4 Practices for Force Verification of Testing Machines
 E 6 Terminology Relating to Methods of Mechanical Testing

3. Terminology

3.1 Definitions:

3.1.1 Definitions of terms and symbols relating to this test method appear in Terminologies E 6 and ~~the Appendix to Test Method D 638.~~ D 883.

4. Summary of Test Method

4.1 This test method consists of impregnating glass fiber strands, yarns, or rovings with a suitable polymeric binder material and loading the resulting test specimens to failure in a tension testing machine having a constant-rate-of crosshead movement. The cross sectional area is determined from skeins of glass fiber taken before and after each set of test specimens. After impregnation and curing, the specimens shall either be tabbed using glass fiber mat or cardboard and tested in accordance with standard grips; or the procedure outlined in 4.1.1.

4.1.1 *Procedure*—~~The test specimen is cut to a specified length and tested using rubber-faced grips, ends shall be sanded with 240 grit sandpaper, fine emery cloth, sandpaper or combination thereof. fine emory cloth and tested using rubber faced grips.~~

5. Significance and Use

5.1 Tensile properties determined by this test method are of value for identifying and characterizing materials for control and specification purposes as well as for providing data for research and development studies.

5.2 This test method is intended for use in testing resin-compatible sized glass fiber materials that have been designed specifically for use with certain generic types of plastics. The use of a resin impregnant that is compatible with the reinforcement material under test produces results that are most representative of the actual strength that is available in the material when used as intended in an end item. Premature reinforcement failure may occur if the elongation of the resin system is less than that of the reinforcement being tested. This requirement may restrict the use of certain resin systems in this procedure. Misleading results may be obtained when glass fiber materials are tested dry without complete resin impregnation of the fiber or when a non-compatible resin impregnant is used for impregnation.

5.3 This test method is useful for testing pretreated specimens for which comparative results are desired. ~~The reproducibility of test results is good when precise control is maintained over all test conditions.~~ Values obtained by this test method may be affected by gage length, gripping system, testing speed, and the resin impregnation ratio of the specimen.

6. Apparatus

6.1 *Impregnation Apparatus*—An example of an acceptable impregnation apparatus for strands is shown in Fig. 1; ~~and for rovings and yarns in Fig. 2.~~ Minor modifications to the apparatus are acceptable providing consistent samples are produced. The apparatus shall consist essentially of the following:

6.1.1 *Free Wheeling Spindle (Optional)*—A freely turning spindle with a horizontal axis for holding the yarn spool or roving ball. ~~A spindle is not required for testing strands because the material is~~ allows fiber to be pulled over the end from a yarn bobbin or the outside of a roving package. Alternatively, the fiber may be drawn from the package without the spindle as in the case of pulling from the interior of a roving package or forming cake.

6.1.2 *Guide Eye/Tension Regulating System* capable of maintaining the roving or yarn under tension between 0.2 Newtons and ~~Pulley—A ceramic guide eye, 25 mm (1.0 in.) in diameter, and a freewheeling pulley, 20 mm (0.8 in.) minimum groove diameter, to guide the material as illustrated in Fig. 3.~~ Newtons.

6.1.3 *Impregnation Tank*, as illustrated in Fig. ~~3 and Fig. 4,~~ 2, consisting of a container and a static spreader bar ~~assembly having at least three bars, each a minimum assembly.~~ The tank must have the capability of 8 mm (5/16 in.) diameter, made maintaining the required resin temperature within ±5°C. This may be accomplished by use of a corrosion-resistant material. double walled vat, with heating fluid circulating between the walls, or by use of an external heating plate.

6.1.4 *Winding Fixture*—A typical winding fixture for glass fiber strands and yarns is shown ~~Die~~, as illustrated in Fig. ~~5,~~ 3, made of stainless steel which gives a defined circular cross-section to the impregnated roving.

6.1.5 *Winding Device and Frame*—for collecting the impregnated roving which insures that the fibers are kept under constant tension and places the strands onto the fixture in Fig. 6—a manner which allows separate specimens to be fabricated.

6.2 *Cutting Gage*—~~A typical cutting gage is~~ Template for Tabbing (Optional)—A template, as shown in Fig. ~~7.~~ 4, This tool eliminates the need for measuring the specimens manually.

6.3 *Tension Testing Machine*—A testing machine having a constant-rate-of-crosshead movement and comprising essentially the following shall be available:

6.3.1 *Stationary Member*, ~~carrying with~~ one grip.

6.3.2 *Movable Member*, ~~carrying with~~ a second grip.

6.3.3 *Grips*—Grips for holding the test specimen between the fixed and the movable member shall be of the self-aligning type (that is, they shall be attached to the fixed and movable members in such a manner that they will move freely into alignment as

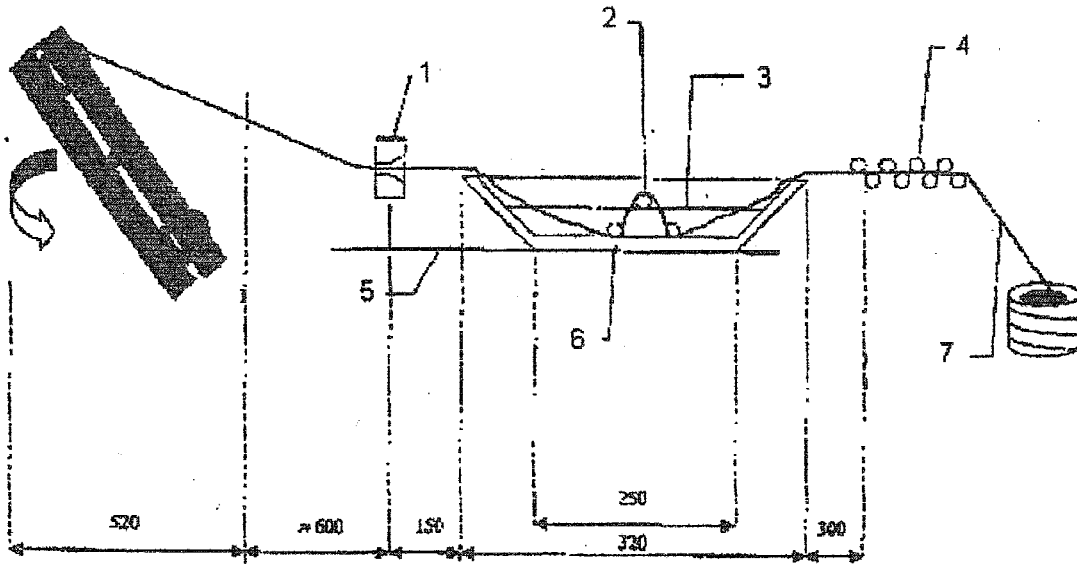

FIG. 1 Typical Impregnating Apparatus for Configurations

- | | |
|---------------------|--|
| 1 Die | 5 Moving Support |
| 2 Tensioning Bars | 6 Impregnation Vat (temperature regulated) |
| 3 Resin Level | 7 Glass Input |
| 4 Tensioning Device | |

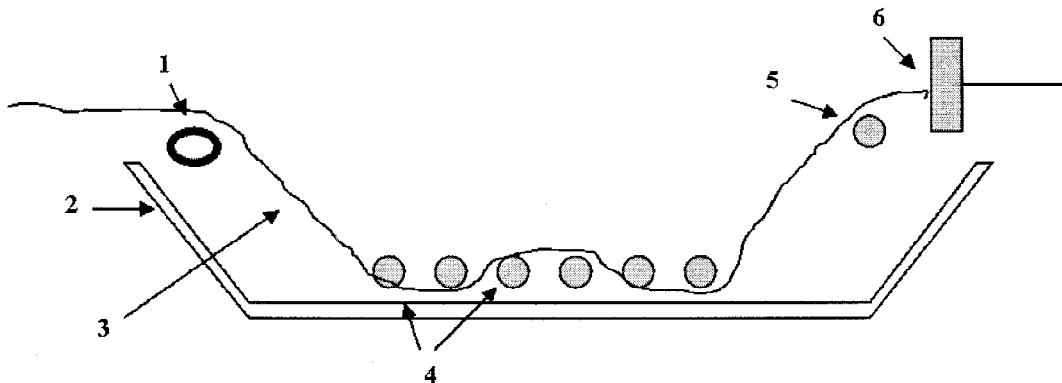

FIG. 2 Typical Impregnating Apparatus for Rovings and Yarns

- | | |
|------------------------|-----------------------|
| 1 Entrance Guide Eye | 4 Breaker Bars |
| 2 Impregnating Vat | 5 Exit Tensioning Bar |
| 3 Glass Roving or Yarn | 6 Die |

soon as any load is applied). The long axis of the test specimens will then coincide with the direction of the applied pull through the center line of the grip assembly.

NOTE 4—Air-actuated grips have been found advantageous and are recommended for use in this test method.

NOTE 5—Rubber with a Shore A hardness of 91 has been found to work well as a grip surface.

NOTE 6—Recommended starting gripping pressures are 80 bars for specimens with no tabs, 60 bars for specimens with cardboard tabs, and 40 bars for composite tabs. These may be adjusted as necessary to prevent slippage providing damage to the specimen due to crushing is prevented.

6.3.4 Jaws—A set of removable jaws to match the required grips shall be used for clamping the test specimens. One of the faces of the jaws shall be adjustable to compensate for thickness of the specimen ends, so that the tension force may be lined up is aligned with the center of the jaw. Rubber-faced jaws, 25 by 102 mm (1.0 by 4.0 in.), with a gripping length of at least 50 mm, shall be used for gripping specimens unless tabs are used. The jaws shall be wider than the test specimen and shall have a gripping length of at least 50 mm. Their faces shall be plane and parallel and shall ensure uniform pressure over the whole width of the test specimen to assure the specimen is held without slippage. If slippage of the test specimens is observed, 240 grit sandpaper strips may shall be used to improve gripping. The sandpaper should be replaced when it has lost its grittiness, or after every 30 to 50 breaks. Alternatively, tabbing shall be used.

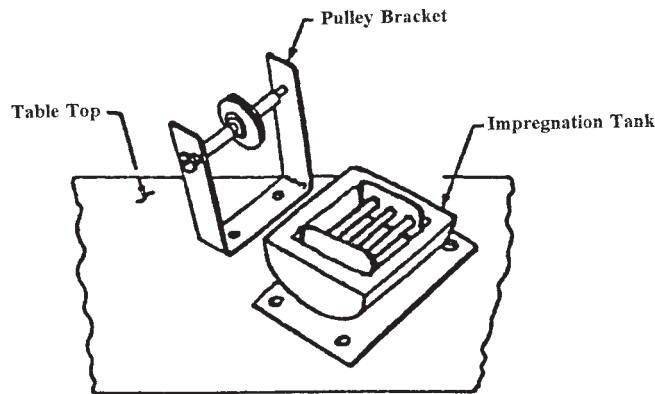

FIG. 3 Guide Pulley and Impregnation Tank

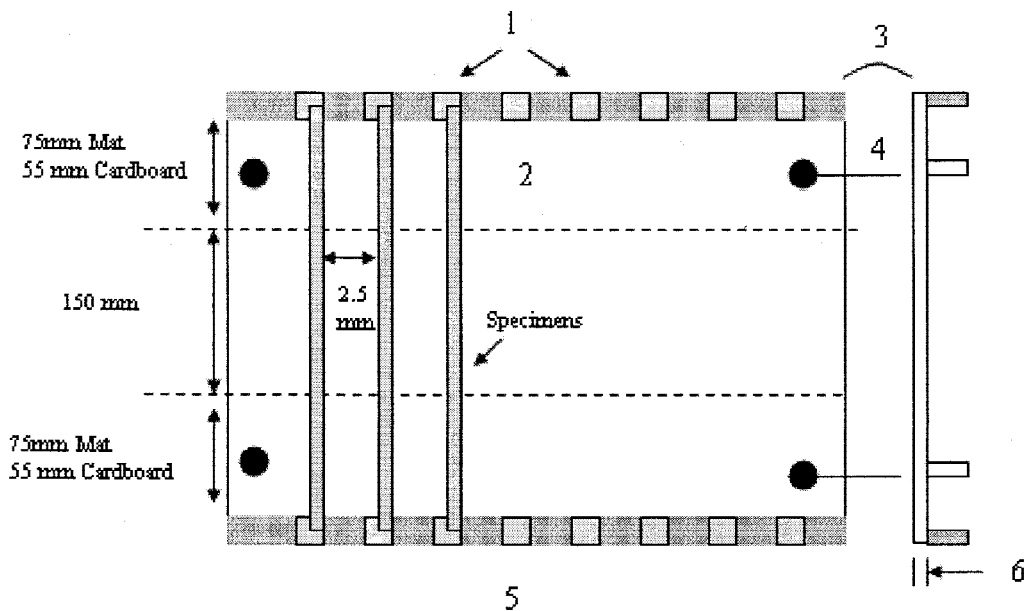

FIG. 4 St Tatbvic Brng Templakter Bar

1 Notches for locations for impregnated rods
 2 Position for strip of cardboard or mat
 3 Border

4 Dimension depending on number of specimens
 5 Thickness of cardboard or mat
 6 Stops

6.3.5 *Drive Mechanism*—A drive mechanism capable of imparting a uniform controllable speed to the movable member of the apparatus.

6.3.6 *Load Indicator*—A suitable load-indicating mechanism capable of showing the total tensile load carried by the test specimen when held by the grips shall be used. This mechanism shall be essentially free of inertial lag at the specified rate of testing and shall indicate the load with an accuracy of at least $\pm 1\%$ of the indicated load value. The accuracy of the testing machine shall be verifiable in accordance with Practices E 4.

6.3.7 *Deflection-Measuring Device and Recorder*—A suitable instrument for measuring deflection (extensometer) and a suitable mechanism for recording this deflection shall be provided. It is desirable that this instrument and recorder automatically record this deflection as a function of the load on the test specimen. An extensometer gauge length of 50 mm is recommended.

6.4 *Balance, Analytical.*

7. Test Specimens

7.1 Test specimens shall consist of straight lengths of impregnated glass fiber strands, yarns, or roving. The lengths shall be $356 \text{ mm } (14 \text{ in.}) \pm 3.2 \text{ mm } (\frac{1}{8} \text{ in.})$, at least 250 mm.

7.2 *Effective Gage Length*—The distance between the tabs or the distance between the rubber faced jaws shall be $254 \pm 1 \text{ mm } (10.0 \pm 0.04 \text{ in.})$, 150 mm.

7.3 *Number of Specimens*—At least five tension test specimens shall be tested for each ball or spool of glass fiber material and for each property tested.

7.4 Glass Content—The glass content of the impregnated glass samples shall be $70 \pm 5\%$ unless otherwise specified.

8. Conditioning

8.1 Strands, Yarns, and Rovings Conditioning—

The glass fiber from which test specimens are to be prepared shall be kept in a room or enclosed space maintained at $23 \pm 2^\circ\text{C}$ ($73.4 \pm 3.6^\circ\text{F}$) and $50 \pm 5\%$ relative humidity in accordance with Procedure A of Practice D 618, except that 24 h shall be the minimum conditioning time.

8.2 *Test Specimen Conditioning*—The specimens shall be conditioned and tested in a room or enclosed space maintained at atmospheric conditions of $23 \pm 2^\circ\text{C}$ ($73.4 \pm 3.6^\circ\text{F}$) and $50 \pm 5\%$ relative humidity in accordance with Procedure A of Practice D 618, except that 3 h shall be the minimum conditioning time.

9. Speed of Testing

9.1 Speed of testing shall be the relative rate of motion of the grips or test fixtures during test. ~~Rate of motion of the driven grip or fixture when the machine is running idle may be used if it can be shown that the resulting speed of testing is within the limits of variation allowed.~~ test.

9.2 The standard speed of testing is 10 mm/min for tensile strength and 5 mm/min for apparent modulus of elasticity ~~shall be $12.7 \pm 0.3\text{ mm (}0.50 \pm 0.01\text{ in.)/min. unless otherwise specified.$~~

10. Impregnation Procedure

10.1 Set up the impregnating apparatus in accordance with ~~Fig. 1 or Fig. 2.~~ 1.

10.2 Cover the ends of the winding fixture using 0.025 mm (0.001 in.) nominal thickness, heat-resistant plastic film, aluminum foil, or equivalent parting film.

10.3 Prepare a sufficient quantity of an impregnant suitable for impregnating the material under test. Pour the impregnating mixture into the tank so that the level is about 10 mm (0.39 in.) above the static breaker bars (see ~~Fig. 3 and Fig. 4.~~ 2.)

10.4 Immediately prior to threading the material through the impregnation apparatus, cut a $1000 \pm 1\text{-mm}$ ($40 \pm 0.04\text{-in.}$) skein of the material under test. Repeat the procedure immediately after winding one set of specimens. Place the two skeins in a muffle furnace maintained at a temperature that will give complete burn-off (usually 450°C for 2 h). Remove the two skeins from the furnace and place in a desiccator for a minimum of 15 min. Weigh the two skeins to the nearest 0.001 g and record as Weight X.

10.5 Select a stripper die of the proper diameter by using the ~~chart or calculations in 13.2 and 13.3.~~ 12.3.

10.6 Thread the glass fiber material through the impregnating apparatus in an “under, over, under” path through the static spreader bars. Firmly attach the end of the glass fiber to the winding fixture with heat-resistant masking tape. Drape the material on the winding fixture. Rotate the fixture either manually or ~~motorized~~ at a motorized rate not exceeding 8 m/min (26-ft/min) (which is equivalent to approximately 7 r/min for the winding fixture described in this test method—see Fig. 5). ft/min).

10.6.1 Maintain an impregnant-to-glass weight ratio satisfactory of 70% for the preparation of the test specimens (see Note 5). Generally, an impregnant weight equivalent to $40 \pm 10\%$ is needed.

NOTE 7—The choice of die and the tex of the fiber will determine the glass content. It may also be affected by the viscosity of the resin used. Use the calculations in 12.2 to determine the die size to be used. If the impregnant-to-glass ratio is excessively high or low, erratic test results calculated die size does not yield the needed glass-weight ratio, then adjustment of the die diameter will be obtained. Hence, when directly comparable results are desired, all specimens should have similar impregnant-to-glass ratios. needed.

10.6.2 After the required number of specimens are wound, hold the winding tension on the material and use heat-resistant masking tape to attach the material to the winding fixture. Cut the material after attachment has been made.

NOTE 8—Optionally, a flat tongue depressor or metal spatula may be used to flatten the end 100 mm (3.9 in.) of the glass strands. This flattening of the gripped portion of the strands allows better clamping of the specimens while minimizing crushing in the grip-jaws. When a solvent diluted impregnant is used, allow the loaded winding fixture to stand horizontally for at least 15 min so that the solvent can evaporate. If a nonsolvent impregnant is used, allow the fixture to stand on end for at least 15 min so that excess impregnant will drain. jaws.

10.6.3 Place the loaded winding fixture in a horizontal position in an air-circulating oven at a temperature and for the required a length of time and at necessary to cure the required temperature. resin per manufacturers instructions. After curing, cool to room temperature and remove the specimens from the winding fixture.

~~10.7 Using a typical specimen cutting gage (see Fig. 7), cut~~

10.7 Cut the specimens to the required length. During all handling, exercise Exercise care to prevent damage to the specimens during handling.

10.8 Select specimens for the test on the basis of their uniformity and freedom from cuts, nicks, or other visible imperfections. Discard any unacceptable specimens. Weigh each specimen selected to the nearest 0.001 g and record as Weight Y.

NOTE 9—A thorough wetting of the glass fiber is essential to obtaining acceptable specimens. It is important that the specimens be examined visually to ensure that good wet-out of the fibers by the resin has occurred. If acceptable wet out is not obtained, it shall be necessary to adjust the configuration of the fibers through the breaker bars in the impregnation bath by changing the over under pattern. A note regarding the quality of wet-out is required in the report.

10.9 If tabbing is to be used, lay out the cut specimens on the template and prepare a suitable quantity of adhesive (epoxy for

cardboard; polyester for mat). Place two strips of chopped strand glass fiber mat (75 mm wide) or cardboard (55 mm wide) at their locations on the template on a metal plate and coat them with adhesive. Place the test specimens and then apply two additional strips of tabbing material. Place another metal plate on top of the tabs and specimens. Place the template, tabs, specimens, and plate into an oven and cure the tab resin at the temperature and duration recommended by the manufacturer. Upon removal from the oven, allow to cool and cut the tabbing to create individual tabbed test specimens. Take care not to damage the impregnated glass specimens.

11. Testing Procedure

11.1 ~~S~~For testing tensile stress, set the speed of the testing machine at $12.7 \text{ mm} \pm 0.3 \text{ mm} (0.50 \pm 0.01 \text{ in.})/\text{min.}$ 10 mm/minute.

11.2 Adjust the load scale range so that it shall be adequate for the estimated breaking load of the specimen under test.

11.3 Set the jaws at the effective gage length of $254 \pm 1 \text{ 150 mm} (10.0 \pm 0.04 \text{ in.})$ 2 mm apart. Place the specimen in the jaws, taking care to ensure alignment of the specimen axis on the grips with an imaginary line joining the points of the attachments of the grips to the machine. If mechanical grips are used, tighten the jaws evenly and firmly to the extent necessary to prevent slippage of the specimen during the test, but not to the point where the specimen is crushed.

11.4 ~~Zero the machine. If modulus is being determined, set up the deflection measuring device (extensometer) machine~~ and start the recorder. Load the test specimen to failure. Record the ultimate breaking load.

11.5 Compute the stress using the equation in 12.3.

NOTE 10—It is assumed for the purpose of this test that only the glass is involved in the rupturing process. This introduces a very slight error, but simplifies the calculation.

11.6 A test result is the average of five test specimens.

11.7 The type of rupture should be noted. A correct break is an instantaneous rupture of the specimen. Fiber rupture which is not instantaneous, or de-bonding or breakage outside the gauge area should be noted and additional samples tested.

11.8 Retest specimens that break or shatter at some obvious fortuitous flaw, or outside the gage length of the specimen (jaw breaks) unless such flaws constitute a variable under study.

11.9 If modulus is being determined set up the deflection measuring device (extensometer) within the test gage length and set the test speed to 5 mm/min. Start the recorder. Repeat the procedure using the average of five test specimens for a test result.

12. Retests

~~12.1 Specimens that break or shatter at some obvious fortuitous flaw, or outside the gage length of the specimen (jaw breaks), shall be discarded and retests made, unless such flaws constitute a variable under study.~~

13. Calculation

~~13.1 Calculations~~

~~12.1 Resin Content—Calculate the—the resin content of the produced specimens can be calculated as follows:~~

$$\text{resin content, weight \%} = (Y/L_2 - X/L_1)/(Y/L_2) \times 100 \tag{1}$$

where:

Y = cured specimen weight,

L₂ = length of cured specimen,

X = two skeins weight after burnoff, and

L₁ = total of two skeins length.

~~13.2 Cross Sectional Area—Calculate of the Glass— Calculate the cross sectional area of the specimen glass fiber (A_o) to be used in the determination of stress to three significant figures, as follows:~~

$$A_o = X/L_1 P \tag{2}$$

$$A_o = \sqrt{\frac{p_1 \times 10^{-3}}{p}} \tag{2}$$

~~L₁p~~

where:

~~A_{oL₁}~~ = ~~cross-sectional area, the exact linear density of the unsized roving, in tex, and~~

~~X/p~~ = ~~the density of the glass of the roving, in grams per cubic centimetre.~~

~~12.3 Required Stripper Die Size—Calculate the stripper die diameter (d) required to produce an impregnated strand with a desired 70 ± 5 weight after burnoff,~~

~~L_T~~ % resin content using the following table or equation:

p	=	total of two skeins length, and	
p (tex)	=	total of two skeins length, and	
P	=	density of glass.2400	4800
P 1200	=	2400	4800

d (mm)	0.8	1.1	1.15	1.4
h (mm)	1	1.3	1.5	2

13.3 Required Stripper Die Size—Calculate the stripper die diameter (SDD) required to produce an impregnated strand with a desired 40 ± 10 weight % resin content (see Note 6) as follows: or

$$SDD = \sqrt{[(A_G + V_G)4] + \pi} \quad (3)$$

$$d = \sqrt{\frac{4p(1/\text{glass}\% - 1 + pm/pg)}{1000pm\pi}} \quad (3)$$

pg

where:

A_{pm} = cross sectional area, in.², matrix density, and
 V_G/pg = desired glass volume, % glass density.

NOTE 611—To convert from weight % to volume % proceed as follows: Divide the weight % of both the glass and resin each by their respective specific gravities, then divide each result in turn by the sum of the quotients, for example, to convert glass weight % to volume % the following applies:

$$\text{volume \% glass} = (W_G/S_G)/[(W_G/S_G) + (W_R/S_R)] \quad (4)$$

where:

W_G = weight % of glass ($60 \pm 10\%$), glass,
 W_R = weight % of resin ($40 \pm 10\%$), resin,
 S_G = specific gravity of glass, and
 S_R = specific gravity of resin.

13.4 Tensile Strength—Calculate the tensile strength by dividing the ultimate breaking load by the average cross sectional area of the two skeins. Report the results to three significant figures.

13.5 Tensile Modulus of Elasticity—Obtain the tensile modulus of elasticity by extending the initial linear portion of the load strain curve and dividing the difference in stress corresponding to a certain section of this straight line by the related difference in strain. Report the results to three significant figures (see Note 7).

NOTE 7—For 12—The specific gravity of the glass and resin must usually be obtained from the respective manufacturer.

12.4 Tensile Stress—Calculate the tensile stress (σ_r) by dividing the ultimate breaking load by the average cross sectional area of drawing the tangent two skeins (from Eq 2). Report the results to three significant figures.

$$\sigma_r = \frac{F_r}{A_a} \quad (5)$$

where:

F_r = the breaking force in newtons, and
 A_a = the cross sectional area of the glass as computed by Eq 2.

12.5 Tensile Modulus of Elasticity—Obtain the tensile modulus of elasticity by extending the initial linear portion of the load strain curve, see curve and dividing the difference in stress corresponding to a certain section of this straight line by the Appendix related difference in strain. Report the results to Test Method D 638.

14. three significant figures.

$$E = \frac{F \times p}{10^{-3} p_l} \times \frac{L_o}{\Delta L} \quad (6)$$

where:

F = the measured force, in newtons, corresponding to ΔL ,
 L_o = the gage length, in millimetres, of the extensometer,
 ΔL = the elongation, in millimetres, corresponding to F ,
 P_l = the exact linear density of the roving, in tex, and
 p = the density, in grams per cubic centimetre, of the glass from which the fiber is made.

13. Report

143.1 Report the following information:

143.1.1 Complete identification of the glass material tested, including type, source, and manufacturer's lot number, and other pertinent information,

143.1.2 Impregnating system, including the name of the manufacturer, resin formulation, elongation, and cure cycle,

143.1.3 Method of preparing test specimen, including static spreader bar description (for example, number of bars, spacing,

etc.), stripper die diameter, and pulling speed,

- 143.1.4 Number of specimens tested,
- 143.1.5 Specimen gage length,
- 143.1.6 Speed of testing,
- 143.1.7 Breaking load,
- 143.1.8 Cross-sectional area of glass roving,
- 143.1.9 Tensile strength of each specimen, average value, and standard deviation,
- 143.1.10 Tensile modulus of elasticity (if measured),
- 143.1.11 Density of glass,
- 143.1.12 Resin content,
- 143.1.13 Conditioning procedure used,
- 143.1.14 Atmospheric conditions in the test room (temperature and relative humidity),
- 143.1.15 Date of test, and
- 143.1.16 Condition of wet-out (good, marginal, poor) of samples.

14. Precision and Bias

14.1 The repeatability (single laboratory) standard deviation has been determined for 1200 tex and 2400 tex roving. These results are shown in Table 1. Attempts to develop a full precision and bias statement for this test method have been unsuccessful. For this reason, data on precision and bias cannot be given. Because this test method does not contain a round robin based numerical precision and bias statement, it shall not be used as a referee test method in case of dispute. Anyone wishing to participate in the development of precision and bias data should contact the Chairman, Subcommittee D20.18, ASTM International, 100 Barr Harbor Drive, West Conshohocken, PA 19428.

15. Keywords

- 15.1 glass fibers; impregnated glass strands; reinforced plastics; rovings; tensile strength; yarns

SUMMARY OF CHANGES

This section identifies the location of selected changes to this test method. For the convenience of the user, Committee D20 has highlighted those changes that may impact the use of this test method. This section may also include descriptions of the changes or reasons for the changes, or both.

D 2343 - 03:

- (1) Almost completely revised in order to make it technically equivalent to the short method in ISO 9163.
- (2) Use of non-mandatory language has been corrected.

ASTM International takes no position respecting the validity of any patent rights asserted in connection with any item mentioned in this standard. Users of this standard are expressly advised that determination of the validity of any such patent rights, and the risk of infringement of such rights, are entirely their own responsibility.

This standard is subject to revision at any time by the responsible technical committee and must be reviewed every five years and if not revised, either reapproved or withdrawn. Your comments are invited either for revision of this standard or for additional standards and should be addressed to ASTM International Headquarters. Your comments will receive careful consideration at a meeting of the responsible technical committee, which you may attend. If you feel that your comments have not received a fair hearing you should make your views known to the ASTM Committee on Standards, at the address shown below.

This standard is copyrighted by ASTM International, 100 Barr Harbor Drive, PO Box C700, West Conshohocken, PA 19428-2959, United States. Individual reprints (single or multiple copies) of this standard may be obtained by contacting ASTM at the above address or at 610-832-9585 (phone), 610-832-9555 (fax), or service@astm.org (e-mail); or through the ASTM website (www.astm.org).

<u>Variable</u>	<u>N</u>	<u>Mean</u>	<u>StDev</u>
<u>Stress (1200 Tex)</u>	<u>6</u>	<u>1573.4</u>	<u>57.2 MPa</u>
<u>Modulus (1200 Tex)</u>	<u>6</u>	<u>70.211</u>	<u>0.786 GPa</u>
<u>Stress (2400 Tex)</u>	<u>4</u>	<u>1813.1</u>	<u>197.0 MPa</u>
<u>Modulus (2400 Tex)</u>	<u>4</u>	<u>72.053</u>	<u>1.578 GPa</u>