



Designation: D 2457 – 9703

Standard Test Method for Specular Gloss of Plastic Films and Solid Plastics¹

This standard is issued under the fixed designation D 2457; the number immediately following the designation indicates the year of original adoption or, in the case of revision, the year of last revision. A number in parentheses indicates the year of last reapproval. A superscript epsilon (ϵ) indicates an editorial change since the last revision or reapproval.

1. Scope*

1.1 This test method describes procedures for the measurement of gloss of plastic films and solid plastics, both opaque and transparent. It contains ~~three~~ four separate gloss angles (Note 1):

1.1.1 60-deg, recommended for intermediate-gloss films,

1.1.2 20-deg, recommended for high-gloss ~~films, and films,~~

1.1.3 45-deg, recommended for intermediate and low-gloss films, and

1.1.4 75-deg, recommended for plastic siding and soffit.

NOTE 1—The 75-deg, 60-deg, and 20-deg apparatus and method of measurement duplicate those in Test Method D 523; those for the 45° procedure are similarly taken from Test Method C 346.

1.2 *This standard does not purport to address all of the safety concerns, if any, associated with its use. It is the responsibility of the user of this standard to establish appropriate safety and health practices and determine the applicability of regulatory limitations prior to use.*

NOTE 2—There is no similar or equivalent ISO standard.

2. Referenced Documents

2.1 *ASTM Standards:*

C 346 Test Method for 45° Specular Gloss of Ceramic Materials²

¹ This test method is under the jurisdiction of ASTM Committee D20 on Plastics and is the direct responsibility of Subcommittee D20.40 on Optical Properties . Current edition approved ~~Jan. August 10, 1997; 2003.~~ Published ~~May 1997; October 2003.~~ Originally published as ~~D 2457—65 T; approved in 1965.~~ Last previous edition approved in 1997 as D 2457 – 907.

- D 523 Test Method for Specular Gloss³
- E 284 Terminology of Appearance³
- E 691 Practice for Conducting an Interlaboratory Study to Determine the Precision of a Test Method⁴
- E 1347 Test Method for Color and Color-Difference Measurement by Tristimulus (Filter) Colorimetry³
- E 1349 Test Method for Reflectance Factor and Color by Spectrophotometry Using Bidirectional Geometry³

3. Terminology

3.1 *Definitions*—For definitions of terms used in this test method, see Terminology E 1284.

~~3.2 Definitions of Terms Specific to This Standard:~~

~~3.2.1 specular gloss, n —(1) ratio of flux reflected in specular direction to incident flux for a specified angle of incidence and source and receptor angular apertures. (2) perceived surface brightness associated with the luminous specular (regular) reflection of a surface. (CIE)~~

~~3.2.2 gloss reflectance factor, R_g , n —ratio of the specularly reflected part of the (whole) flux reflected from the specimen to the flux reflected from a specified gloss standard under the same geometric and spectral conditions of measurement.~~

~~3.2.2.1 Discussion—The gloss standard may be a black glass or a mirror and may be assigned one of a variety of scale values as specified. E 284.~~

4. Significance and Use

4.1 Specular gloss is used primarily as a measure of the shiny appearance of films and surfaces. Precise comparisons of gloss values are meaningful only when they refer to the same measurement procedure and same general type of material. In particular, gloss values for transparent films should not be compared with those for opaque films, and vice versa. Gloss is a complex attribute of a surface which cannot be completely measured by any single number.

4.2 Specular gloss usually varies with surface smoothness and flatness. It is sometimes used for comparative measurements of these surface properties.

5. Apparatus

5.1 *Instrumental Components*—Each apparatus (Note 3) shall consist of an incandescent light source furnishing an incident beam, means for locating the surface of the specimen, and a receptor located to receive the required pyramid of rays reflected by the specimen. The receptor shall be a photosensitive device responding to visible radiation.

NOTE 3—The 75-, 60-, and 20-deg procedures require apparatus identical to that specified in Test Method D 523. The 45° procedure requires apparatus like that specified in Test Method C 346.

5.2 *Geometric Conditions*—The axis of the incident beam shall be at one of the specified angles from the perpendicular to the specimen surface. The axis of the receptor shall be at the mirror reflection of the axis of the incident beam. With a flat piece of polished black glass or other front-surface mirror in specimen position, an image of the source shall be formed at the center of the receptor field stop (receptor window). The length of the illuminated area of the specimen shall be equal to not more than one third of the distance from the center of this area to the receptor field stop. The angular dimensions and tolerances of the geometry of the source and receptor shall be as indicated in Table 1. The angular dimensions of the receptor field stop are measured from the center of the test surface. The angular dimensions of the source field stop are mostly easily measured by the specimen-to-window angular size of the mirror image of the source formed in the receptor field stop. (See Fig. 1 for a generalized illustration of the dimensions.) The tolerances are chosen so that errors of no more than one gloss unit at any point on the scale will result from errors in the source and receptor aperture.

5.3 *Vignetting*—There shall be no vignetting of rays that lie within the field angles specified in 5.2.

5.4 *Spectral Conditions*—Results should not differ significantly from those obtained with a source-filter-photocell combination that is spectrally corrected to yield CIE luminous efficiency with CIE Source C. Since specular reflection is, in general, spectrally nonselective, spectral corrections need be applied only to highly chromatic, low-gloss specimens upon agreement of users of this test method.

² Annual Book of ASTM Standards, Vol 02.05.

³ Annual Book of ASTM Standards, Vol 06.01.

⁴ Annual Book of ASTM Standards, Vol 14.02.

TABLE 1 Angular Dimensions and Tolerances of Geometry of Source and Receptor Field Stops

Geometry, deg	Incidence Angle, deg	Source Field Stop		Receptor Field Stop	
		In Plane of Measurement, deg	Perpendicular to Plane of Measurement, deg	In Plane of Measurement, deg	Perpendicular to Plane of Measurement, deg
75	75 ± 0.1		3.0 max		
60	60 ± 0.1	0.75 ± 0.25	3.0 max	4.4 ± 0.1	11.7 ± 0.2
20	20 ± 0.1	0.75 ± 0.25	3.0 max	1.80 ± 0.05	3.6 ± 0.1
45	45 ± 0.1	1.4 ± 0.4	3.0 ± 1.0	8.0 ± 0.1	10.0 ± 0.2

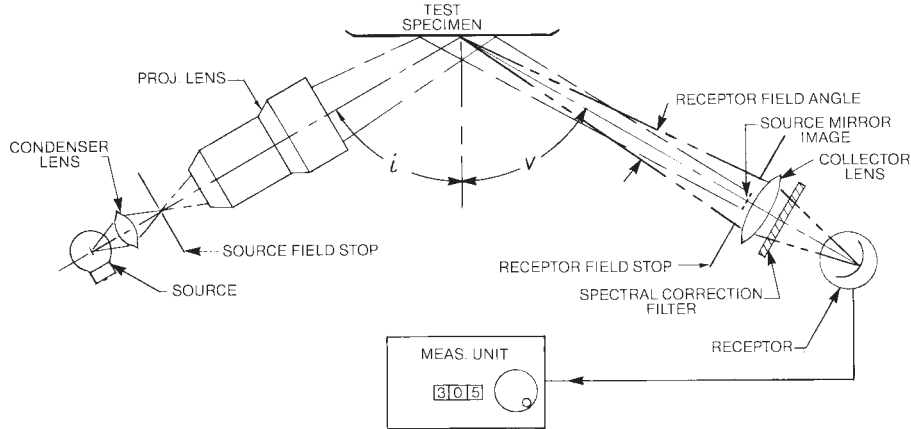

FIG. 1 Diagram of Glossmeter Showing Essential Components and Dimensions

5.5 *Measurement Mechanism*—The receptor-measurement mechanism shall give a numerical indication that is proportional to the light flux passing the receptor field stop within ± 1 percent of full-scale reading.

6. Reference Standards

6.1 *Primary Working Standards* may be highly polished, plane, black glass surfaces. The specular reflectance, in percent, (R_s) of such surfaces shall be computed by the following equation:

$$R_s \text{ (percent)} = 50 \left[\left[\frac{\cos i - \sqrt{n^2 - \sin^2 i}}{\cos i + \sqrt{n^2 - \sin^2 i}} \right]^2 + \left[\frac{n^2 \cos i - \sqrt{n^2 - \sin^2 i}}{n^2 \cos i + \sqrt{n^2 - \sin^2 i}} \right]^2 \right] \tag{1}$$

where:

- i = the specular (incidence) angle, and
- n = the index of refraction of the surface.

Multiply the computed R_s at each angle by the scale factors shown in Table 2.

NOTE 4—On the 45 and 60° scales, a perfect mirror measures 1000.

6.2 *Secondary Working Standards* of ceramic tile, glass, porcelain enamel, or other materials having hard, flat, and uniform surfaces may be calibrated from the primary standard on a glossmeter determined to be in strict conformance with the requirements prescribed in 5.2.

7. Preparation and Selection of Test Specimens

7.1 This test method does not cover preparation techniques. Whenever a test for gloss requires the preparation of a test specimen, report the technique of specimen preparation.

~~7.2 Specimen surfaces shall~~

7.2 Test results have ~~good planarity, since been found to be seriously affected by surface warpage, waviness, or curvature may seriously affect test results. The curvature.~~ Ensure that specimen surfaces have good planarity. Perform tests with the directions of machine marks, or similar texture effects, ~~shall be both parallel and perpendicular to the plane of the axes of the two incident and reflected beams,~~ unless otherwise specified. (Note that this does not avoid the second-surface reflection.)

7.3 Surface test areas shall be kept free of soil and abrasion. Gloss is due chiefly to reflection at the surface; therefore, anything that changes the surface physically or chemically is likely to affect gloss.

8. Mounting Films for Measurement

8.1 Any nonrigid film must be mounted in a device that will hold it flat, but will not stretch the film while it is measured. Three different filmholding devices have each proved satisfactory for at least some types of films:

TABLE 2 Scale Factors for Gloss Standards, Perfect Mirror and Perfect Matt White^A

Geometry	Scale Factors (multiply R_s of black glass standard by)	Value for Black Glass when $n = 1.540$	Value for Perfect Mirror	Value for Perfect Matt White
60°	10.0	95.8	1000	2.1
20°	20.3	92.3	2030	1.4
45°	10.0	55.9	1000	5.4

^A The latter are useful for estimating corrections to gloss readings for reflection from sample backing (see Note 6).

8.1.1 *Vacuum Plate* (see Fig. 2) is required for stiff films. Connect the vacuum plate by rubber tube to a vacuum pump or vacuum line. With thin, soft films it is sometimes necessary to use a valve and pressure gage and to limit the vacuum so as to keep from collapsing the soft film into the pores of the ground plate.

8.1.2 *Flat Plate* with two-side pressure-sensitive tape (see Fig. 3). Make sure each specimen is pulled smooth, but not stretched before holding it by the two strips of adhesive tape. Replace the tape whenever it loses its adhesiveness.

8.1.3 *Telescoping Ring or Hoop* (see Fig. 4)—To mount the specimen in the telescoping ring, lay the flexible film over the base (male) section and drop the top over the base. Push down carefully, taking care to pull the test film taut without stretching it. Measure the taut area.

8.2 *Backing for Films That Transmit Light*—A matt black backing or (even better) a black cavity must be placed behind any film that transmits light. Erroneous measurements will occur without a suitable trap or backing.

9. Procedure

9.1 Operate the glossmeter in accordance with the manufacturer's instructions.

9.2 Calibrate the instrument at the start and completion of every period of glossmeter operation and during the operation at sufficiently frequent intervals to assure that the instrument response is practically constant. If at any time an instrument fails to repeat readings of the standard to within 2 percent of the prior setting, the intervening results should be rejected. To calibrate, adjust the instrument to read correctly the gloss of a highly polished standard, and then read the gloss of a standard having poorer image-forming characteristics. If the instrument reading for the second standard does not agree within 1 percent of its assigned value, do not use the instrument without readjustment, preferably by the manufacturer.

NOTE 5—Correct readings on black-glass and intermediate standards do not guarantee instrument conformity to specification requirements. In addition to measurements with gloss standards, dimensional checks for conformity to the geometric requirements of 4.2 should be made.

9.3 *Reduction of Amplification to Read over 100 Gloss Films on 0 to 100 Gloss Scale*—A single smooth surface with refractive index of 1.567 measures 100 on both the 60 and 20-deg scales. Clear plastic films have two specularly reflecting surfaces. Even though they are less than perfectly smooth and less than 1.567 in refractive index, adding the reflections from the two surfaces frequently leads to gloss values of more than 100. If these gloss values are off-scale on the glossmeter used, recalibrate the instrument with the reading of the primary gloss standard set to a smaller value f (such as $f = 50$) and correct the gloss readings by multiplying them by $(100/f)$.

9.4 Position each specimen (mounted in a holder in the case of films) in turn beneath (or on) the glossmeter. For specimens with extrusion lines or other direction texture effects, orient them in such a way that the direction of the marks is both parallel and perpendicular to the plane of the axes of the incident and reflected beams. Measure at least three portions of the specimen surface in each direction to obtain an indication of uniformity. If no directionality is detected in the specimen, then the test may be performed only in the parallel or perpendicular orientation.

NOTE 6—In the case of films, it is often desirable to compare these readings with readings taken across the machine direction. Difference in the readings will relate to the prominence of the machine marks.

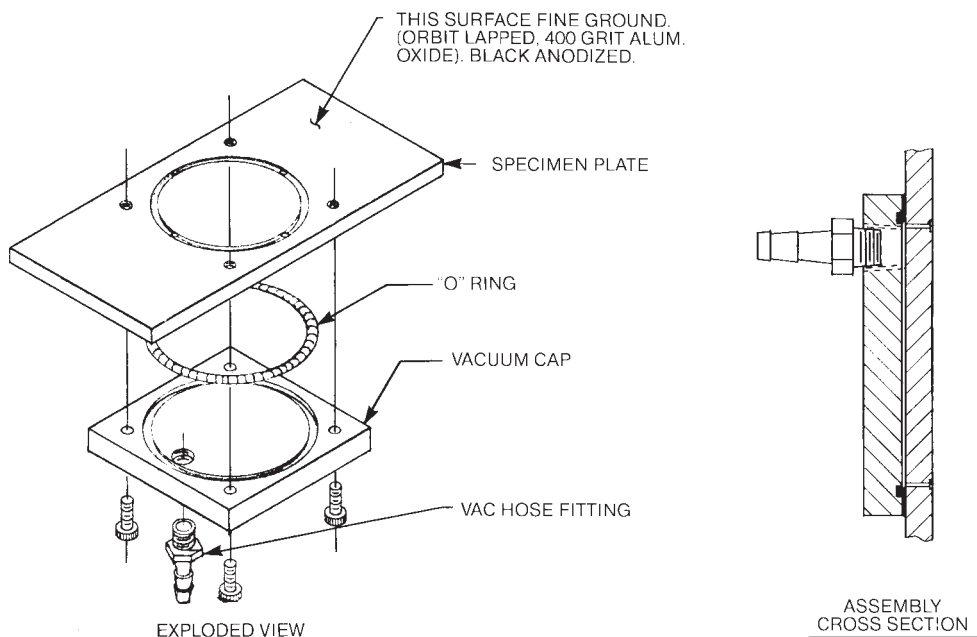

FIG. 2 Vacuum Plate Used to Hold Films Flat

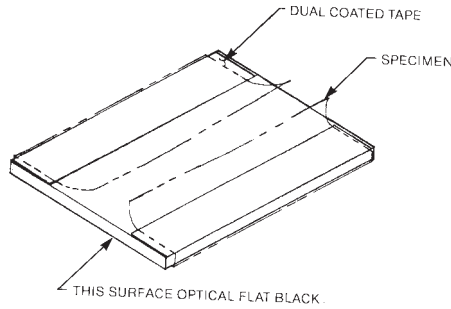

FIG. 3 Flat Plate with Two-Sided Pressure-Sensitive Tape Used to Hold Flexible Films for Gloss Measurement

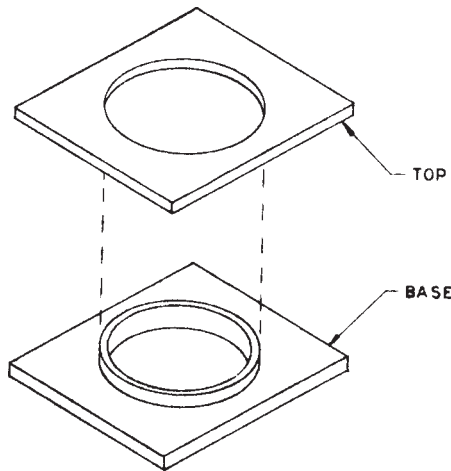

FIG. 4 Telescoping Ring Used to Hold Flexible Films for Gloss and Haze Measurements

10. Report

10.1 Report the following information:

- 10.1.1 Type of specimen, its gloss (mean of three readings for each direction or mean of both directions), nominal thickness, whether transparent, and the specimen holder employed if specimen is a film.
- 10.1.2 All individual gloss readings for a specimen shall be reported if any of the gloss readings differ by more than 10 % from the average for that specimen.
- 10.1.3 Where preparation of the test specimen has been necessary, description or identification of the method of preparation,
- 10.1.4 Identification of the glossmeter by the manufacturer's name and model designation, and
- 10.1.5 Identification of the working standard or standards of gloss used.

NOTE 7—*Diffuse Correction*—It can be said that the light reflected by a specimen may be divided into one part reflected specularly in the direction of mirror reflection (associated with gloss) and another part reflected diffusely in all directions (associated with lightness on the white-gray-black scale). According to this picture, a gloss reading always needs to be diminished to compensate for that amount of the measured light attributable to diffuse reflectance. Although it is seldom possible in practice to analyze reflected light according to this picture and say exactly what part is diffuse and what part is specular, it is nevertheless frequent practice where gloss values of light and dark surfaces are being compared to “correct” (diminish) specular gloss settings for diffuse reflectance. If diffuse corrections are desired as additional information, measure 45-deg, 0-deg luminous directional reflectances of specimens in accordance with Test Methods E 1347 or E 1349. Multiply reflectance values in percentage by the following factors⁵ for diffuse corrections in gloss units:

60-deg	0.021
20-deg	0.013
45-deg	0.055

11. Precision and Bias

11.1 Table 3, Table 4 and Table 5 are based on a round robin conducted in 1987 and 1988 per Practice E 691 involving seven test samples. The test results in Table 3 were from 13 labs; Table 4 from seven labs and Table 5 from five labs. For each material, all samples were from a single roll of film or a single injection molding run. Each lab obtained two test results on separate days for each material. ~~NOTE 8—Caution:~~

⁵ Taken from Test Methods D 523 and C 346.

TABLE 5 Precision Data

		20° Gloss (5 Labs) ^A						
		Average	S _r ^{AB}	S _R ^{BC}	V _r ^{ED}	V _R ^{DE}	I _r ^{EF}	I _R ^{FG}
M	PP	0.66	0.14	0.95	21.6	144.4	1.85	2.66
O								
L	PP	19.1	1.04	3.19	5.4	16.7	2.91	8.93
D								
I	PP	78.8	3.92	8.81	5.0	11.2	11.0	24.7
N								
G	PC	96.9	2.37	4.83	2.4	5.0	6.64	13.5
F	LLDPE	71.3	1.00	17.71	1.4	24.9	2.80	49.6
I								
L	OPP	97.1	9.05	31.44	9.3	32.4	25.3	88.0
M	PET	169.4	9.26	21.02	5.5	12.4	25.9	58.9

^AResults were obtained using unknown directional orientation.

^BS_r = within-laboratory standard deviation of a test result.

^{BC}S_R = between-laboratories standard deviation of a test result.

^{ED}I_r = 2.8 S_r / (average) * 100

^{DE}I_R = 2.8 S_R / (average) * 100

^{EF}V_r = (S_r / average) * 400

^{FG}V_R = (S_R / average) * 400

TABLE 3 Precision Data

		45° Gloss (13 Labs) ^A						
		Average	S _r ^{AB}	S _R ^{BC}	V _r ^{ED}	V _R ^{DE}	I _r ^{EF}	I _R ^{FG}
M	PP	9.87	0.230	1.48	2.3	15.0	0.64	4.14
O								
L	PP	38.7	0.82	3.00	2.1	7.7	2.38	8.40
D								
I	PP	53.6	0.79	1.16	1.5	2.2	2.21	3.25
N								
G	PC	62.4	1.03	1.03	1.6	1.6	2.88	2.88
F	LLDPE	83.6	1.35	3.11	1.6	3.7	3.78	8.71
I								
L	OPP	89.7	2.39	3.03	2.7	3.4	6.69	8.48
M	PET	115.2	0.86	3.49	0.7	3.0	2.41	9.77

^AResults were obtained using unknown directional orientation.

^BS_r = within-laboratory standard deviation of a test result.

^{BC}S_R = between-laboratories standard deviation of a test result.

^{ED}I_r = 2.8 S_r / (average) * 100

^{DE}I_R = 2.8 S_R / (average) * 100

^{EF}V_r = (S_r / average) * 400

^{FG}V_R = (S_R / average) * 400

TABLE 4 Precision Data

		60° Gloss (7 Labs) ^A						
		Average	S _r ^{AB}	S _R ^{BC}	V _r ^{ED}	V _R ^{DE}	I _r ^{EF}	I _R ^{FG}
M	PP	14.1	0.53	1.94	3.7	1.9	1.48	5.43
O								
L	PP	80.6	1.35	2.34	1.7	2.3	3.78	6.55
D								
I	PP	92.7	0.70	1.10	0.8	1.1	1.96	3.08
N								
G	PC	99.8	0.71	6.16	0.7	6.2	1.99	17.2
F	LLDPE	126.3	1.54	7.74	1.2	6.0	4.31	21.7
I								
L	OPP	143.4	2.56	3.37	1.8	1.5	7.17	9.44
M	PET	152.3	3.38	8.73	2.2	5.3	9.46	24.4

^AResults were obtained using unknown directional orientation.

^BS_r = within-laboratory standard deviation of a test result.

^{BC}S_R = between-laboratories standard deviation of a test result.

^{ED}I_r = 2.8 S_r / (average) * 100

^{DE}I_R = 2.8 S_R / (average) * 100

^{EF}V_r = (S_r / average) * 400

^{FG}V_R = (S_R / average) * 400

11.2 Warning—The following explanations of I_r and I_R (11.3.1-11.3.3) are only intended to present a meaningful way of considering the approximate precision of the data in Table-1, 3, Table-2 4 and Table-3 5 and should not be rigorously applied to

acceptance or rejection of material, as those data are specific to the round robin and may not be representative of other lots, conditions, materials, or laboratories. 11.2— Users of this test method should apply the principles outlined in Practice E 691 to generate data specific to their laboratory and materials, or between specific laboratories. The principles of 11.3.1-11.3.3 would then be valid for such data.

11.3 *Concept of I_r and I_R* —If S_r and S_R have been calculated from a large enough body of data, (Use Table 3.5 with caution as only five labs participated) and for test results that were averages from testing five specimens then the following definitions of S_r and S_R are valid.

11.3.1 *Repeatability I_r* —In comparing two test results for the same material, obtained by the same operator using the same equipment on the same day, the two test results should be judged not equivalent if they differ by more than I_r value for that material.

11.3.2 *Reproducibility I_R* —In comparing two test results for the same material, obtained by different operators using different equipment on different days, the two test results should be judged not equivalent if they differ by more than the I_R value for that material.

11.3.3 Any judgment made in accordance with 11.3.1 and 11.3.2 would have an approximate 95 % (0.95) probability of being correct.

11.4 *Bias*—is systematic error which contributes to the difference between a test result and a true (or reference) value. There are no recognized standards on which to base an estimate of bias for this test method.

12. Keywords

12.1 gloss; plastic films; solid plastics

SUMMARY OF CHANGES

This section identifies the location of selected changes to this test method. For the convenience of the user, Committee D20 has highlighted those changes that may impact the use of this test method. This section may also include descriptions of the changes or reasons for the changes, or both.

D 2457 - 03:

(1) Removed definitions that are included in terminology standards.

(2) Added specimen directionality evaluation.

(3) Updated Precision and Bias references and wording.

(4) Added 75° gloss measurement where applicable in the test method.

ASTM International takes no position respecting the validity of any patent rights asserted in connection with any item mentioned in this standard. Users of this standard are expressly advised that determination of the validity of any such patent rights, and the risk of infringement of such rights, are entirely their own responsibility.

This standard is subject to revision at any time by the responsible technical committee and must be reviewed every five years and if not revised, either reapproved or withdrawn. Your comments are invited either for revision of this standard or for additional standards and should be addressed to ASTM International Headquarters. Your comments will receive careful consideration at a meeting of the responsible technical committee, which you may attend. If you feel that your comments have not received a fair hearing you should make your views known to the ASTM Committee on Standards, at the address shown below.

This standard is copyrighted by ASTM International, 100 Barr Harbor Drive, PO Box C700, West Conshohocken, PA 19428-2959, United States. Individual reprints (single or multiple copies) of this standard may be obtained by contacting ASTM at the above address or at 610-832-9585 (phone), 610-832-9555 (fax), or service@astm.org (e-mail); or through the ASTM website (www.astm.org).