



Standard Test Method for Shrink Tension and Orientation Release Stress of Plastic Film and Thin Sheeting¹

This standard is issued under the fixed designation D 2838; the number immediately following the designation indicates the year of original adoption or, in the case of revision, the year of last revision. A number in parentheses indicates the year of last reapproval. A superscript epsilon (ϵ) indicates an editorial change since the last revision or reapproval.

1. Scope

1.1 This test method covers the determination of the shrink tension and related characteristics, that is, shrink force and orientation release stress, of heat-shrinkable plastic film and sheeting of less than 1.0 mm (0.04 in.) thickness. Two procedures are described that permit the measurement of shrink forces at predetermined temperatures. They are as follows:

1.1.1 *Procedure A* is designed to measure the maximum force exerted by a specimen that is totally restrained from shrinking as it is heated rapidly to a specific temperature.

1.1.2 *Procedure B* is designed to measure the maximum force exerted by a specimen that is permitted to shrink a predetermined amount prior to restraint while being heated rapidly to a specific temperature.

1.2 Orientation release stress can be determined from the data obtained using Procedure A.

1.3 The values stated in SI units are to be regarded as the standard. The values in parentheses are for information only.

NOTE 1—There is no equivalent ISO test method.

1.4 *This standard does not purport to address all of the safety concerns, if any, associated with its use. It is the responsibility of the user of this standard to establish appropriate safety and health practices and determine the applicability of regulatory limitations prior to use.*

2. Referenced Documents

2.1 ASTM Standards:

D 374 Test Methods for Thickness of Solid Electrical Insulation²

D 618 Practice for Conditioning Plastics and Electrical Insulating Materials for Testing³

D 883 Terminology Relating to Plastics³

D 6287 Practice for Cutting Film and Sheeting Test Specimens⁴

¹ This test method is under the jurisdiction of ASTM Committee D20 on Plastics and is the direct responsibility of Subcommittee D20.19 on Film and Sheeting. Current edition approved April 10, 2002. Published June 2002. Originally published as D 2838 – 69. Last previous edition D 2838 – 95.

² *Annual Book of ASTM Standards*, Vol 10.01.

³ *Annual Book of ASTM Standards*, Vol 08.01.

⁴ *Annual Book of ASTM Standards*, Vol 08.03.

E 1 Specification for ASTM Thermometers⁵

3. Terminology

3.1 Definitions of Terms Specific to This Standard:

3.1.1 *orientation release stress, n*—the maximum shrink tension developed by a film in a specified direction throughout its range of shrink temperatures while totally restrained from shrinking.

3.1.2 *shrink force, n*—the force per original unit width developed by a film in a specified direction and at a specified temperature in its attempt to shrink while under restraint.

3.1.3 *shrink tension, n*—the force per original average cross-sectional area developed by a film in a specified direction and at a specified temperature in its attempt to shrink while under restraint.

3.2 Definitions:

3.2.1 For definitions of terms used in this test method, refer to Terminology D 883.

4. Summary of Test Method

4.1 A 25.4-mm (1-in.) wide strip of film or sheeting is clamped in the arms of a shrink tension holder (see Fig. 1), one arm of which contains a strain gage. The holder is immersed in a hot bath and the force exerted by the film is measured by the strain gage. The data is collected by a data acquisition device. The tests may be carried out with or without free shrinkage of the material before restraint.

5. Significance and Use

5.1 As a result of the manufacturing process, internal stresses are locked into the film and these can be released by heating. For any given type of film or sheeting, the temperatures at which shrinkage will begin are related to processing techniques employed to manufacture the film and also may be related to a phase transition in the base resin.

5.2 Shrink tension affects the appearance and performance of a film in a shrink-packaging application. It may also be used to determine the degree and direction of orientation. The orientation exerts a great influence upon important physical

⁵ *Annual Book of ASTM Standards*, Vol 14.03.

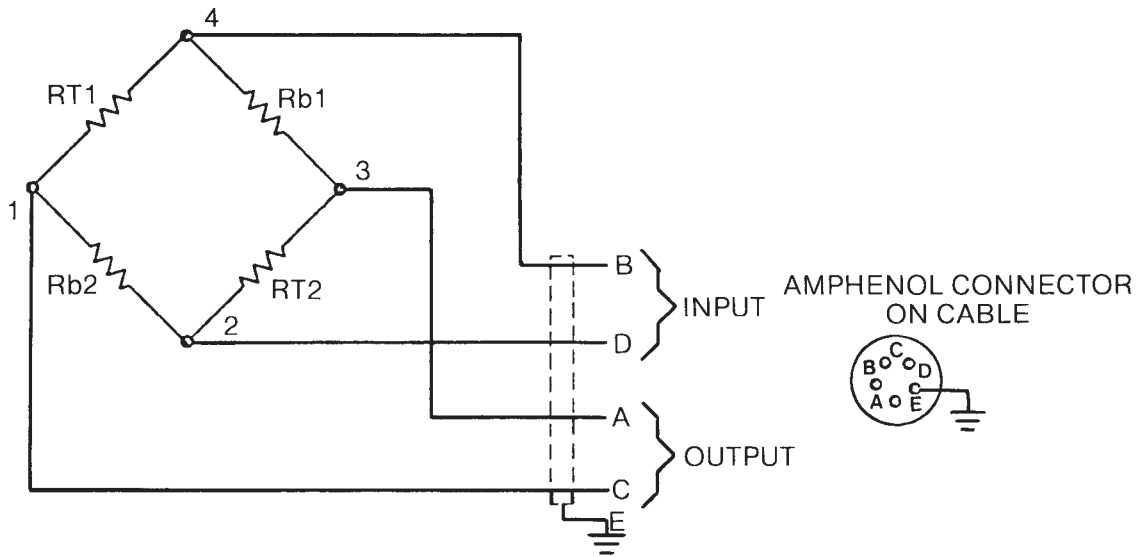

RT 1 and 2 Top Strain Gages
Rb 1 and 2 Bottom Strain Gages

FIG. 2 Circuit Diagram for Shrink, Tension Holder

7. Sampling

7.1 No single procedure for all situations can be given, but Practice D 1898 provides guidelines for use in planning sampling procedures.

8. Test Specimens

8.1 The test specimens shall consist of strips of uniform width and thickness. The width of the specimens shall be 25.4 ± 0.2 mm (1.0 ± 0.01 in.).

8.2 Length of Test Specimens:

8.2.1 Specimens for Procedure A shall be at least 127 mm (5 in.) in length.

8.2.2 Length of specimens for Procedure B is dependent upon the amount of shrink desired prior to restraint. At least 50 mm shall be allowed for clamping. The remaining length required can be calculated by solving for *L* in the following equation:

$$L = (d / (100 - s)) \times 100 \tag{1}$$

where:

- L* = specimen length required between clamps, mm or in.,
- d* = distance between clamps, mm or in., and
- s* = percent shrink desired prior to restraint.

Measure a distance equivalent to *L*, leaving at least 25.4 mm (1 in.) at either end of the strip for clamping and mark the beginning and termination of the distance with a line perpendicular to the edge and across the width of the strip.

8.3 Measure the thickness of the specimen to the nearest 0.0025 mm (0.0001 in.) at a minimum of four positions, but at least at each 25.4 mm (1 in.) along the length of the specimen that will be between the clamps. Record the thicknesses. Calculate and record their average.

8.4 For each measurement of shrink tension at a given temperature, test at least four specimens from each direction, machine and transverse, of the test sample.

9. Preparation of Apparatus

9.1 Set up constant-temperature bath and equilibrate at the temperature chosen for the test. Shrink tension will normally be observed near the softening temperature of polymeric material.

9.2 Balance and set the data acquisition device at zero in accordance with the manufacturer’s instructions.

10. Calibration

10.1 Zero shrink holder with no load on shrink arm.

10.2 Place a weight (normally 4.45 N, 454 gf, 1 lbf) equal to the chosen full-scale value for the measurements to be made on the shrink arm. Adjust the data acquisition device to full scale in accordance with the manufacturer’s instructions.

10.3 Check linearity by placing weights of less mass on the arm. If the response is non-linear, have the equipment repaired to make response linear.

10.4 Re-check the zero of the shrink holder with no load on the shrink arm.

11. Conditioning

11.1 *Conditioning*—Condition the test specimens at 23 ± 2°C (73.4 ± 3.6°F) and 50 ± 5 % relative humidity for not less than 40 h prior to test in accordance with Procedure A of Practice D 618, unless otherwise specified by contract or the relevant ASTM material specification. Reference pre-test conditioning, to settle disagreements, shall apply tolerances of ±1°C (1.8°F) and ±2 % relative humidity

11.2 *Test Conditions*—Conduct tests at 23 ± 2°C (73.4 ± 3.6°F) and 50 ± 5 % relative humidity, unless otherwise specified by contract or the relevant ASTM material specification. Reference testing conditions, to settle disagreements, shall apply tolerances of ±1°C (1.8°F) and ±2 % relative humidity.

12. Procedure A—Totally Restrained

12.1 Clamp the first specimen in the holder under the minimum positive loading force achievable. Under no circumstances should it exceed the maximum force observed after immersion of the specimen. The holder must be at ambient temperature.

12.2 Initiate data collection before immersing holder into bath. Immerse the shrink holder and specimen into the bath, taking special care to lower it in such a manner that the specimen remains in a horizontal position. Immerse smoothly and quickly without bumping or jerking the holder. Keep the specimen in the bath long enough to reach a peak or plateau and 2 to 3 s thereafter.

NOTE 2—Slight variations from the horizontal will generally produce a negligible error. The error, however, will increase in significance as the shrink force approaches zero. A jig may be used to aid in maintaining the proper alignment of the holder while immersing the specimen.

12.3 Stop data collection and immerse the holder in a beaker of cold water until it returns to ambient temperature. Then remove the specimen.

12.4 Repeat 12.1-12.3 for each specimen in the set.

12.5 Repeat 12.1-12.4 for temperature increments of no more than 10°C through the shrink temperature range of the film or sheeting under test. This is usually the softening temperature range of the material.

13. Procedure B—Predetermined Shrink Before Restraint

13.1 Clamp the specimen in the holder so that the lines marked in 8.2.2 coincide with the inside edges of the clamps.

13.2 Follow the instructions given in 12.1-12.5.

14. Calculation

14.1 Record the maximum force (peak or plateau whichever is greater) to the nearest 0.045 N (0.01 lbf or 4.5 gf).

14.2 *Shrink Force*—Divide the maximum force by the specimen width to obtain shrink force. Express shrink force in either newtons per metre or pounds-force per inch.

14.3 *Shrink Tension*—Divide the maximum force in newtons (or pounds force) by the product of the average thickness in millimetres (inches) and the specimen width in millimetres (inches) to obtain the shrink tension in pascals.

15. Orientation Release Stress

15.1 Prepare graphs of shrink tension as a function of temperature for each film direction of interest, using data obtained by Procedure A.

15.2 The maximum shrink tension developed for each direction of interest, as determined by the graphs prepared in 15.1, is the orientation release stress.

16. Report

16.1 Report the following information:

16.1.1 Complete sample identification,

16.1.2 Procedure used,

16.1.3 Percent shrink prior to restraint,

16.1.4 Test temperature,

16.1.5 Film direction (longitudinal, transverse),

16.1.6 Number of specimens tested,

16.1.7 Average thickness of each specimen,

16.1.8 Shrink force of each specimen,

16.1.9 Shrink tension of each specimen,

16.1.10 Average results, standard deviation, and confidence limits where applicable, and

16.1.11 Orientation release stress, film direction, and temperature where it occurs, plus plots used to obtain it.

17. Precision and Bias

17.1 *Repeatability*—The standard deviation of measurements of shrink force within a laboratory is usually a function of the magnitude of the measurement between the limits of 9.8 N/m (0.056 lbf/in.) and 175 N/m (1.0 lbf/in.). The standard deviation will increase with the magnitude of the measurement. The percent coefficient of variation ($\sigma/\bar{X} \times 100$) will generally not exceed 10 %.

17.2 *Reproducibility*—The standard deviation of averages of shrink force obtained by different laboratories is relatively constant for measurements between the limits of 9.8 N/m (0.056 lbf/in.) and 175 N/m (1.0 lbf/in.) and generally will not exceed 5.8 N/m (0.034 lbf/in.).

17.3 *Bias*—The bias of this test method cannot be assessed since applicable accepted reference materials are not available.

18. Keywords

18.1 film; orientation release stress; shrink force; shrink tension; thin sheeting

ASTM International takes no position respecting the validity of any patent rights asserted in connection with any item mentioned in this standard. Users of this standard are expressly advised that determination of the validity of any such patent rights, and the risk of infringement of such rights, are entirely their own responsibility.

This standard is subject to revision at any time by the responsible technical committee and must be reviewed every five years and if not revised, either reapproved or withdrawn. Your comments are invited either for revision of this standard or for additional standards and should be addressed to ASTM International Headquarters. Your comments will receive careful consideration at a meeting of the responsible technical committee, which you may attend. If you feel that your comments have not received a fair hearing you should make your views known to the ASTM Committee on Standards, at the address shown below.

This standard is copyrighted by ASTM International, 100 Barr Harbor Drive, PO Box C700, West Conshohocken, PA 19428-2959, United States. Individual reprints (single or multiple copies) of this standard may be obtained by contacting ASTM at the above address or at 610-832-9585 (phone), 610-832-9555 (fax), or service@astm.org (e-mail); or through the ASTM website (www.astm.org).