



Standard Test Method for Apparent Bending Modulus of Plastics by Means of a Cantilever Beam¹

This standard is issued under the fixed designation D 747; the number immediately following the designation indicates the year of original adoption or, in the case of revision, the year of last revision. A number in parentheses indicates the year of last reapproval. A superscript epsilon (ϵ) indicates an editorial change since the last revision or reapproval.

1. Scope *

1.1 This test method covers the determination of the apparent bending modulus² of plastics by means of a cantilever beam. It is well suited for determining relative flexibility of materials over a wide range. It is particularly useful for materials too flexible to be tested by Test Methods D 790.

1.2 The values stated in SI units are to be regarded as the standard. The values given in parentheses are for information only.

1.3 *This standard does not purport to address all of the safety concerns, if any, associated with its use. It is the responsibility of the user of this standard to establish appropriate safety and health practices and determine the applicability of regulatory limitations prior to use.*

NOTE 1—There is no known ISO equivalent for this standard.

2. Referenced Documents

2.1 ASTM Standards:

- D 374 Test Methods for Thickness of Solid Electrical Insulation³
- D 618 Practice for Conditioning Plastics and Electrical Insulating Materials for Testing⁴
- D 790 Test Methods for Flexural Properties of Unreinforced and Reinforced Plastics and Electrical Insulating Materials⁴
- D 4000 Classification System for Specifying Plastic Materials⁵
- D 4066 Specification for Nylon Injection and Extrusion Materials⁵
- E 177 Practice for Use of the Terms Precision and Bias in ASTM Test Methods⁶
- E 691 Practice for Conducting an Interlaboratory Study to

Determine the Precision of a Test Method⁶

3. Terminology

3.1 Definitions of Terms Specific to This Standard:

3.1.1 *apparent bending modulus*—an apparent modulus of elasticity obtained in flexure, using a cantilever beam testing apparatus, where the deformation involved is not purely elastic but contains both elastic and plastic components.

4. Significance and Use

4.1 This test method provides a means of deriving the apparent bending modulus of a material by measuring force and angle of bend of a cantilever beam. The mathematical derivation assumes small deflections and purely elastic behavior. Under actual test conditions, the deformation has both elastic and plastic components. This test method does not distinguish or separate these, and hence a true elastic modulus is not calculable. Instead, an apparent value is obtained and is defined as the apparent bending modulus of the material. The tangent modulus obtained by Test Methods D 790 is preferred, when the material can be tested by the Test Methods D 790 test procedure.

4.2 Because of deviations from purely elastic behavior, changes in span length, width, and depth of the specimen will affect the value of the apparent bending modulus obtained; therefore, values obtained from specimens of different dimensions may not necessarily be comparable.

4.3 Rate of loading is controlled only to the extent that the rate of angular change of the rotating jaw is fixed at 58 to 66°/min. Actual rate of stressing will be affected by span length, width, depth of the specimen, and weight of the pendulum.

4.4 For many materials, there may be a specification that requires the use of this test method, but with some procedural modifications that take precedence when adhering to the specification. Therefore, it is advisable to refer to that material specification before using this test method. Table 1 of Classification System D 4000 lists the ASTM materials standards that currently exist.

NOTE 2—A discussion of the theory of obtaining a purely elastic bending modulus, using a cantilever beam testing apparatus, can be found in Appendix X1. The results obtained under actual test conditions will be

¹ This test method is under the jurisdiction of ASTM Committee D-20 on Plastics and is the direct responsibility of Subcommittee D20.10 on Mechanical Properties. Current edition approved March 10, 1999. Published June 1999. Originally published as D 747 – 43 T. Last previous edition D 747 – 93.

² This property was designated stiffness in versions of this test method issued prior to 1984.

³ *Annual Book of ASTM Standards*, Vol 10.01.

⁴ *Annual Book of ASTM Standards*, Vol 08.01.

⁵ *Annual Book of ASTM Standards*, Vol 08.02.

⁶ *Annual Book of ASTM Standards*, Vol 14.02.

*A Summary of Changes section appears at the end of this standard.

the apparent bending modulus.

5. Apparatus

5.1 The apparatus for the apparent bending modulus test, as shown in Fig. 1, shall be the cantilever beam bending type, consisting essentially of the following:

5.1.1 *Vise*—A specimen vise, V , to which the pointer indicator I_2 is attached, and which is capable of uniform clockwise rotation about the point O at a nominal rate of 60° of arc/min.

5.1.2 *Weighing System*—A pendulum weighing system, including an angular deflection scale, pointer indicator I_1 , bending plate Q for contacting the free end of the specimen, and a series of detachable weights. This system shall be pivoted for nearly frictionless rotation about the point O . The total applied bending moment, M_w , consists of the effective moment of the pendulum and the bending plate, A_1 , plus the moments of the added calibrated weights, A_2 . Thus,

$$M_w = WL \sin \theta \quad (1)$$

where:

- M_w = actual bending moment at the angle θ ,
- W = total applied load, N (or lbf),
- L = length of the pendulum arm, m (or in.), and
- θ = angle through which the pendulum rotates.

NOTE 3—Auxiliary weights for the test apparatus⁷ are calibrated and marked directly with the values for M , the bending moment at a load reading of 100. Since M_w depends on the geometry of the testing machine, these weights are not interchangeable between machines of different capacities.

⁷ This apparatus can be obtained from Tinius Olsen Testing Machine Co., Inc., Easton Road., Willow Grove, PA 19090.

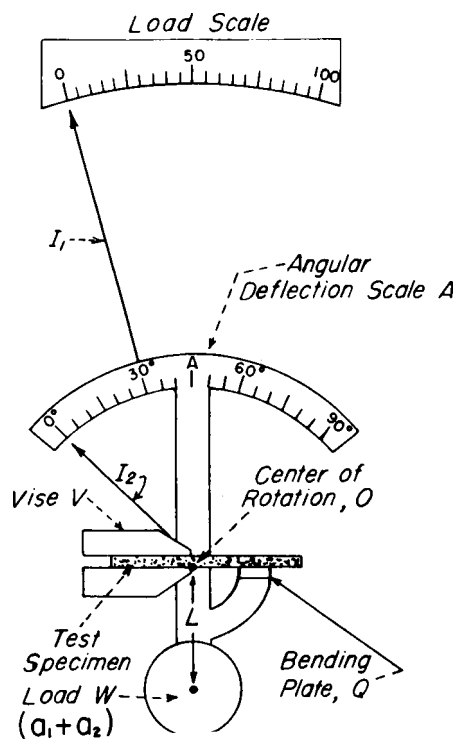

FIG. 1 Mechanical System of Test Apparatus

5.1.3 *Load Scale*—A fixed scale that measures the load as a function of the deflection, θ , of the load pendulum system. It shall be calibrated such that:

$$\text{Load scale reading} = 100 WL \sin \theta / M \quad (2)$$

where:

M = bending moment at a load scale reading of 100.

Thus,

$$M_w = (M \times \text{load scale reading}) / 100 \quad (3)$$

where:

M_w = actual bending moment.

5.1.4 *Angular Deflection Scale*—The angular deflection scale shall be calibrated in degrees of arc and shall indicate the angle through which the rotating vise has been turned relative to the pendulum system. This is the difference between the angle through which the vise has been turned and the angle through which the load pendulum has been deflected, and is designated as angle ϕ .

5.1.5 *Depth Measuring Devices*—Suitable micrometers, or thickness gages, reading to 0.0025 mm (0.0001 in.) or less, shall be used for measuring the depth of the test specimens. The pressure exerted by the gage on the specimen being measured shall be between 159 and 186 kPa (23 and 27 psi). Method A of Test Methods D 374 may be used. Alternatively, the apparatus and procedure of Method C of Test Methods D 374 may be used provided the load on the spindle is increased so that the exerted pressure is between 159 and 186 kPa (23 and 27 psi).

5.1.6 *Width-Measuring Devices*—Suitable scales or other width measuring devices reading to 0.025 mm (0.001 in.) or less shall be used for measuring the width of the test specimen.

6. Test Specimens

6.1 Test specimens may be molded or cut from molded, calendered, or cast sheets of the material to be tested. They shall have a rectangular cross section and shall be cut with their longitudinal axes parallel to the direction of the principal axis of anisotropy, unless anisotropy effects are specifically to be evaluated. The width and depth of the specimen to be tested, as well as the span length, will depend upon the apparent bending modulus of the material and the capacity of the testing machine. Specimens shall have an even surface. If they exhibit a surface tackiness, they shall be dusted lightly with talc before being tested.

6.2 Specimen width shall be between 5.0 and 25.4 mm (0.25 and 1.00 in.), provided the material does not extend over the width of the anvil. Width shall be measured to the nearest 0.025 mm (0.001 in.).

6.3 The minimum specimen depth shall be 0.5 mm (0.020 in.) and shall be measured to the nearest 0.0025 cm (0.0001 in.).

NOTE 4—A minimum specimen depth requirement is included since a large percentage error can result in the final apparent bending modulus value because of small errors in the depth measurement. The reason for this large dependence of apparent bending modulus on depth errors is because the depth is to the third power in the formula.

6.4 The span-to-depth ratio shall be greater than 15 to 1. Large span-to-depth ratios may be limited by the sensitivity of

the load-measuring and deflectometer equipment.

6.5 The number of specimens tested shall be at least five.

7. Conditioning

7.1 *Conditioning*—Condition the test specimens at $23 \pm 2^\circ\text{C}$ ($73.4 \pm 3.6^\circ\text{F}$) and $50 \pm 5\%$ relative humidity for not less than 40 h prior to test in accordance with Procedure A of Practice D 618, for those tests where conditioning is required. In cases of disagreement, the tolerances shall be $\pm 1^\circ\text{C}$ ($\pm 1.8^\circ\text{F}$) and $\pm 2\%$ relative humidity.

7.1.1 Note that for some hygroscopic materials, such as nylons, the material specifications (for example, Specification D 4066) call for testing “dry as-molded specimens.” Such requirements take precedence over the above routine preconditioning to 50 % relative humidity and require sealing the specimens in water vapor-impermeable containers as soon as molded and not removing them until ready for testing.

7.2 *Test Conditions*—Conduct tests in the standard laboratory atmosphere of $23 \pm 2^\circ\text{C}$ ($73.4 \pm 3.6^\circ\text{F}$) and $50 \pm 5\%$ relative humidity, unless otherwise specified in the test methods or in this test method. In cases of disagreement, the tolerances shall be $\pm 1^\circ\text{C}$ ($\pm 1.8^\circ\text{F}$) and $\pm 2\%$ relative humidity.

7.3 Specimens to be tested at temperatures above or below normal shall be conditioned at the test temperature at least 2 h prior to testing, unless shorter equilibration time has been proven. The test apparatus itself should be conditioned 2 h before testing.

7.4 *Lubrication of Test Apparatus*—For operations at temperatures below 0°C (32°F) it may be necessary to remove all the lubricant from the gear box, bearings, etc., of the apparatus and replace it with kerosine or silicone oil.

8. Procedure

8.1 Place the test apparatus on an approximately level surface. Add necessary weights to the pendulum and, if necessary, adjust the load scale to indicate zero. Set the bending pin or plate to the proper bending span as determined in 5.4. Start the motor and keep it running throughout the tests to minimize friction effects in the weighing system.

8.2 For maximum precision choose the value of M so that, at an angle of 3° , the load scale reading is between 5 and 10. If this value is not known, determine it by trial and error using the standard procedure. After obtaining M , test five specimens.

8.3 Firmly clamp the test specimen in the vise with the centerline approximately parallel to the face of the dial plate. By turning the hand crank, apply sufficient load to the specimen to show a 1 % load reading and then set the angle pointer to zero. Record this point and plot it as part of the data.

8.4 Hold down the motor engaging lever and take subsequent load scale readings at 3, 6, 9, 12, and 15° . Do not retest any specimen.

9. Calculation

9.1 Plot the data on coordinate paper with the load scale reading as ordinate and the angular deflection as abscissa.

9.2 Draw the steepest straight line through at least three consecutive points on the plot (see Fig. 2, Fig. 3, and Fig. 4). If this line does not pass through the origin, translate it parallel

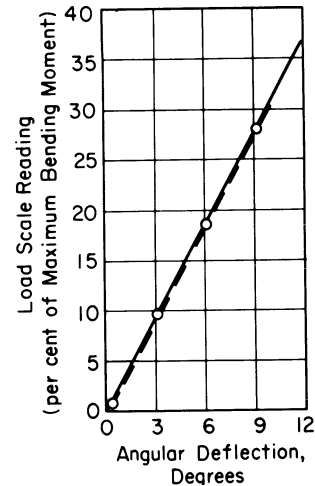

FIG. 2 Ideal Curve

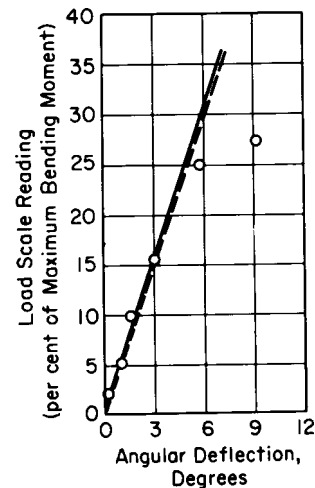

FIG. 3 Typical Curve for Nonrigid Material

to itself until it passes through the origin. Use the data obtained from this line in the equation given in 9.3.

9.3 Calculate the apparent bending modulus to three significant figures, as follows:

$$E_b = (4S/wd^3) \times [(M \times \text{load scale reading})/100 \phi] \quad (4)$$

where:

E_b = apparent bending modulus, Pa (or psi),

S = span length, length measured from the center of rotation of the pendulum weighing system and the specimen vise to the contacting edge of the bending plate, m (or in.),

w = specimen width, m (or in.),

d = specimen depth, m (or in.),

M = total bending moment value of the pendulum system, N·m (or lbf·in.), based on the moment of the basic pendulum system, a_1 , plus the moments indicated on the calibrated weight or weights, a_2 , and

ϕ = reading on angular deflection scale converted to radians (Table 1).

10. Report

10.1 Report the following information:

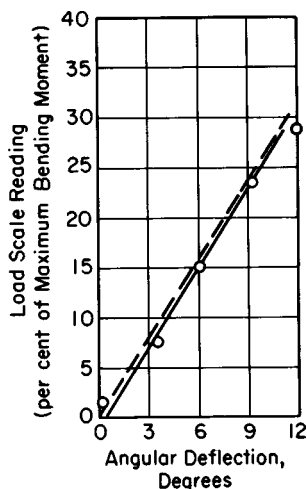

NOTE 1—If this type of curve is obtained, data should be taken at intervals of 5° until it is evident that the maximum slope has been obtained. (This type of curve may be obtained on a specimen that is warped or rough on the surface.)

FIG. 4 Curve for Imperfect Specimen

TABLE 1 Conversion Table: Degrees to Radians^A

Degrees	Radians
3	0.0523
6	0.1047
9	0.1571
12	0.2094
15	0.2618
18	0.3141
20	0.3491
25	0.4363
30	0.5236
35	0.6109
40	0.6981
45	0.7854
50	0.8726
55	0.9599
60	1.0472

^A1 radian = 57° 18 min 1° = 0.01745 radians.

10.1.1 Complete identification of the material tested, including type, source, manufacturer's code number, form, surface, width of the test specimens, span, and directionality,

10.1.2 Average apparent bending modulus and the nominal specimen depth used,

10.1.3 All observed and recorded data on which the calculations are based,

10.1.4 Test temperature, and

10.1.5 Date of test.

11. Precision and Bias ⁸

11.1 Table 2 is based on a round-robin test conducted in 1981, in accordance with Practice E 691, involving four materials tested by seven laboratories. Each "test result" was the average of five individual determinations. Each laboratory obtained two test results for each material.

NOTE 5—**Caution:** The following explanations of *r* and *R* (11.2-11.2.3) are intended only to present a meaningful way of considering the approximate precision of this test method. The data given in Table 2 should not be applied rigorously to the acceptance or rejection of materials, as those data are specific to the round robin and may not be representative of other lots, conditions, materials, or laboratories. Users of this test method should apply the principles outlined in Practice E 691 to generate data specific to their laboratory and materials, or between specific laboratories. The principles of 11.2-11.2.3 would then be valid for such data.

11.2 *Concept of r and R in Table 1*—If *S_r* and *S_R* have been calculated from a large enough body of data, and for test results that were averages from testing five specimens for each test result, then:

11.2.1 *Repeatability*—Two test results obtained within one laboratory shall be judged not equivalent if they differ by more than the *r* value for that material. The *r* value is the interval representing the critical difference between two test results for the same material, obtained by the same operator using the same equipment on the same day in the same laboratory.

11.2.2 *Reproducibility*—Two test results obtained by different laboratories shall be judged not equivalent if they differ by more than the *R* value for that material. The *R* value is the interval representing the critical difference between two test results for the same material, obtained by different operators using different equipment in different laboratories.

11.2.3 The judgments in 11.2.1 and 11.2.2 will have an approximately 95 % (0.95) probability of being correct.

11.3 *Bias*—No statement may be made about the bias of this test method, as there is no standard reference material or reference test method that is applicable.

12. Keywords

12.1 apparent bending modulus; bending movement; cantilever beam; stiffness

⁸ Supporting data are available from ASTM Headquarters. Request RR:D20-1109.

TABLE 2 Apparent Bending Modulus

Material	Mean	Values Expressed in Units of MPa (10 ³ psi)			
		<i>S_r</i> ^A	<i>S_R</i> ^B	<i>r</i> ^C	<i>R</i> ^D
PE	124 (18)	3.44 (0.50)	7.45 (1.08)	9.7 (1.4)	21 (3.1)
PP	1850 (269)	53.4 (7.75)	109 (15.86)	150 (22)	310 (45)
Acetal	2600 (377)	99.6 (14.45)	187 (27.15)	280 (41)	530 (77)
Acrylic	2930 (425)	94.9 (13.76)	144 (20.83)	270 (39)	410 (59)

^A*S_r* is the within-laboratory standard deviation for the indicated material. It is obtained by pooling the within-laboratory standard deviations of the test results from all of the participating laboratories: $S_r = [((S_1)^2 + (S_2)^2 \dots + (S_n)^2) / n]^{1/2}$

^B*S_R* is the between-laboratory reproducibility, expressed as standard deviation: $S_R = \{S_r^2 + S_L^2\}^{1/2}$ where *S_L* is the standard deviation of laboratory means.

^C*r* is the within-laboratory critical interval between two test results = 2.8 × *S_r*.

^D*R* is the between-laboratory critical interval between two test results = 2.8 × *S_R*.

APPENDIX

(Nonmandatory Information)

X1. THEORY OF OPERATION OF THE CANTILEVER BEAM TEST APPARATUS

X1.1 The mechanical system of the cantilever beam test apparatus is described in Section 5 of this test method (Fig. 1).

X1.2 At the start of a test, the specimen is mounted as shown in Fig. X1.1(a). The load indicator I_1 reads zero on the load scale, and the indicator I_2 reads zero on the angular deflection scale. During the test, the specimen vise, V , is rotated about the point O , bending the specimen through the angle ϕ against the plate Q as shown in Fig. X1.1(b). The point P on the specimen has been deflected to P' , and the amount of deflection for small angles is given approximately by:

$$\bar{P}\bar{P}' = M_w S^2 / 3EI = [(WL \sin \theta) S^2] / 3EI \quad (X1.1)$$

where:

- $\bar{P}\bar{P}'$ = deflection of point, P , m (or in.),
- W = applied load, N (or lbf),
- L = length of load pendulum arm to which weights are attached, m (or in.),
- θ = angular deflection of load pendulum system, deg,
- M_w = actual bending moment at the angle θ ,
- S = span length of specimen, m (or in.),
- E = modulus of elasticity in flexure, N/m² (or psi), and
- I = moment of inertia of specimen cross section, which is $wd^3/12$ where w is the specimen width and d is the specimen depth, m (or in.).

The angle, ϕ , through which the specimen bends, (Fig. X1.1(b)), which is registered by the angular deflection scale A and converted to radians, is given by:

$$\phi = \bar{P}\bar{P}' / S = M_w S / 3EI \quad (X1.2)$$

Rearranging Eq X1.2 and substituting $wd^3/12$ for I gives:

$$E = M_w S / 3I\phi = (4S / wd^3) \times (M / \phi) \quad (X1.3)$$

Since the load scale is calibrated such that

$$M_w = (M \times \text{load scale reading}) / 100,$$

Eq X1.3 may be written:

$$E = (4S / wd^3) \times [(M \times \text{load scale reading}) / 100 \phi] \quad (X1.4)$$

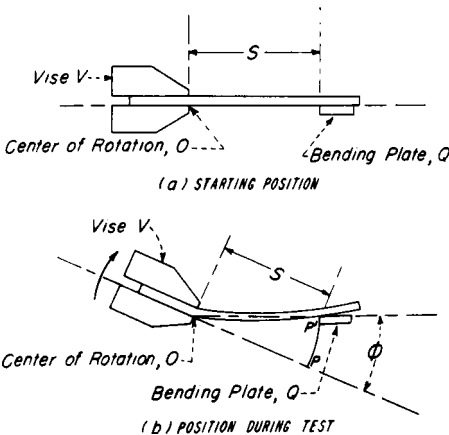

FIG. X1.1 Positions of Test Specimen

SUMMARY OF CHANGES

This section identifies the location of selected changes to this test method. For the convenience of the user, Committee D-20 has highlighted those changes that may impact the use of this test method. This section may also include descriptions of the changes or reasons for the changes, or both.

D 747 - 99:

(I) Changes to scope, ISO equivalency statement added,

precision and bias statement placed in appropriate format, and keywords added.

ASTM International takes no position respecting the validity of any patent rights asserted in connection with any item mentioned in this standard. Users of this standard are expressly advised that determination of the validity of any such patent rights, and the risk of infringement of such rights, are entirely their own responsibility.

This standard is subject to revision at any time by the responsible technical committee and must be reviewed every five years and if not revised, either reapproved or withdrawn. Your comments are invited either for revision of this standard or for additional standards and should be addressed to ASTM International Headquarters. Your comments will receive careful consideration at a meeting of the responsible technical committee, which you may attend. If you feel that your comments have not received a fair hearing you should make your views known to the ASTM Committee on Standards, at the address shown below.

This standard is copyrighted by ASTM International, 100 Barr Harbor Drive, PO Box C700, West Conshohocken, PA 19428-2959, United States. Individual reprints (single or multiple copies) of this standard may be obtained by contacting ASTM at the above address or at 610-832-9585 (phone), 610-832-9555 (fax), or service@astm.org (e-mail); or through the ASTM website (www.astm.org).