



Designation: D 4020 – 01a

Standard Specification for Ultra-High-Molecular-Weight Polyethylene Molding and Extrusion Materials¹

This standard is issued under the fixed designation D 4020; the number immediately following the designation indicates the year of original adoption or, in the case of revision, the year of last revision. A number in parentheses indicates the year of last reapproval. A superscript epsilon (ϵ) indicates an editorial change since the last revision or reapproval.

This standard has been approved for use by agencies of the Department of Defense.

1. Scope*

1.1 This specification provides for the identification of virgin, unmodified ultra-high-molecular-weight polyethylene (UHMW-PE) plastics molding and extrusion materials. This identification is made in such a manner that the seller and purchaser can agree on the acceptability of different commercial lots or shipments.

1.2 It is not intended to differentiate between various molecular weight grades of ultra-high-molecular-weight polyethylene commercially available.

1.3 It is not the function of this specification to provide specific engineering data for design purposes.

1.4 Ultra-high-molecular-weight polyethylenes, as defined in this specification, are those linear polymers of ethylene which have a relative viscosity of 1.44 or greater, in accordance with the test procedures described herein.

1.5 The values stated in SI units are to be regarded as the standard. The values given in parentheses are for information only.

1.6 The following precautionary caveat pertains only to the test method portion. Section 7, of this specification: *This standard does not purport to address all of the safety concerns, if any, associated with its use. It is the responsibility of the user of this standard to establish appropriate safety and health practices and determine the applicability of regulatory limitations prior to use.*

NOTE 1—There is no ISO equivalent specification. However, in ISO 11542-1, a range of viscosity numbers defines the viscosity of UHMW-PE grades. The viscosity numbers are determined in accordance with ISO 1628-3.

2. Referenced Documents

2.1 *ASTM Standards:*

¹ This specification is under the jurisdiction of ASTM Committee D20 on Plastics and is the direct responsibility of Subcommittee D20.15 on Thermoplastic Materials. Current edition approved May 10, 2001. Published January 2002. Originally published as D 4020 – 81. Last previous edition D 4020 – 00a1.

*A Summary of Changes section appears at the end of this standard.

D 883 Terminology Relating to Plastics²

D 1601 Test Method for Dilute Solution Viscosity of Ethylene Polymers²

~~D 1898 Practice for Sampling of Plastics³~~

2.2 ISO Standards:³

² *Annual Book of ASTM Standards*, Vol 08.01.

³ ~~Discontinued; see 1997 *Annual Book of ASTM*~~

³ Available from American National Standards, ~~Vol 08.01~~, Institute, 25 W. 43rd St., 4th Floor, New York, NY 10036.

ISO 11542-1 Plastics—Ultra High Molecular-Weight Polyethylene (PE-UHMW) Moulding and Extrusion Materials—Part 1: Designation System and Basis for Specification
 ISO 1628-3 Plastics—Determination of Viscosity Number and Limiting Viscosity Number—Part 3: Polyethylenes and Polypropylenes

3. Terminology

3.1 *Definitions*—Definitions of terms used in this specification are in accordance with Terminology D 883.

3.2 *Definitions of Terms Specific to This Standard:*

3.2.1 *ultra-high-molecular-weight polyethylene molding and extrusion materials* —as defined by this specification, those substantially linear polyethylenes which have a relative viscosity of 1.44 or greater, at a concentration of 0.02 %, at 135°C, in decahydronaphthalene.

3.2.1.1 *Discussion*—It has been common practice to refer to the “molecular weight” of UHMW-PE resins. The following calculations shall be used to approximate the specific viscosity (η_{sp}), reduced viscosity (η_{red} or R.S.V.), intrinsic viscosity (η or I.V.), and the approximate viscosity average molecular weight of virgin resin. The solution viscosity test on thermally processed material is invalid due to inadequate solubility and possible crosslinking.

$$\text{Relative viscosity} = \eta_r = t_s - t_o - \frac{k}{t_o} \quad (1)$$

$$\text{Relative viscosity} = \eta_r = \left(t_s - \frac{k}{t_s} \right) / \left(t_o - \frac{k}{t_o} \right) \quad (1)$$

$$\text{Specific viscosity} = \eta_{sp} = \eta_r - 1$$

$$\text{Reduced viscosity} = \eta_{red} = \frac{\eta_{sp}}{C}$$

$$\text{Intrinsic viscosity} = [\eta] = (2\eta_{sp} - 2 \ln \eta_{rel})^{1/2} \div c$$

limiting viscosity number at 0 % concentration
 Nominal viscosity molecular weight = $5.37 \times 10^4 [\eta]^{1.37}$

where:

- k = kinetic energy correction constant for the particular viscometer used,
- t_s = flow time of solution at 135°C, s,
- t_o = flow time of pure solvent at 135°C, s, and
- C = concentration.

NOTE 2—There are other equations being used in industry to calculate the viscosity average molecular weights. Refer to Appendix ~~X3~~ X4 for the other equations and their relationship to the viscosity average molecular weight equation in 3.2.1.1. The equation in 3.2.1.1 is the only equation that shall be used for reporting of viscosity average molecular weight.

4. Classification

4.1 It is recognized that dilute solution viscosity measurements can only be made on virgin resin. Therefore, the following test and limits shall be used to determine the properties of virgin polymer only.

5. Materials and Manufacture

5.1 The molding and extrusion material shall be UHMW polyethylene in the form of powder, granules, or pellets.

5.2 The molding and extrusion materials shall be as uniform in composition and size and as free of contamination as can be achieved by good manufacturing practice. If necessary, the level of contamination may be agreed upon between the seller and the purchaser.

5.3 Unless controlled by requirements specified elsewhere in this specification, the color and translucence of molded or extruded pieces, formed under conditions recommended by the manufacturer of the material, will be comparable within commercial match tolerances to the color and translucence of standard molded or extruded samples of the same thickness supplied in advance by the manufacturer of the material.

6. Sampling

6.1 A batch or lot shall be considered as a unit of manufacture and may consist of a blend of two or more production runs of the same material.

6.2 Unless otherwise agreed upon between the seller and the purchaser, the material shall be sampled in accordance with the procedure described in the general and specific sampling procedures of Practice D 1898. Adequate statistical sampling prior to packaging shall be considered an acceptable alternative.

7. Test Method

7.1 *Dilute Solution Viscosity*—Use Test Method D 1601, as modified in Annex A1.

8. Keywords

8.1 extrusion materials; molding materials; plastics; polyethylene; ultra-high-molecular-weight; UHMW-PE; viscosity

ANNEX

(Mandatory Information)

A1. DILUTE SOLUTION VISCOSITY

A1.1 General Description

A1.1.1 The test sequence consists of dissolving UHMW-PE in decahydronaphthalene (0.02 g/100 mL) at 150°C and then measuring the relative viscosity at 135°C in an Ubbelohde No. 1 viscometer. The relative solution viscosity may be calculated from these experimental data.

A1.2 Apparatus

A1.2.1 *Analytical Balance.*

A1.2.2 *Microscope Slide Cover Slip .*

A1.2.3 *Hot Plate*, with magnetic stirrer.

A1.2.4 *Erlenmeyer Flask*, 250-mL, with glass stopper.

A1.2.5 *Vacuum Drying Oven.*

A1.2.6 *Vacuum Aspirator.*

A1.2.7 *Viscometer*, Ubbelohde No. 1.

A1.2.8 *Constant-Temperature Bath* , 135 ± 0.1°C, with a 305-mm diameter by 460 mm (12 by 18-in.) tall glass jar as a container, and having a suitable support for the viscometer.

A1.2.9 *Buret*, 100-mL capacity, 0.1-mL subdivisions.

A1.2.10 *Stopwatch*, 0.2-s reading.

A1.2.11 *Still*, for decahydronaphthalene.

A1.2.12 *Glass Funnel*, with heating mantle.

A1.3 Reagents

A1.3.1 *Decahydronaphthalene*, freshly distilled.

A1.3.2 *Tetrakis*

[methylene 3-(3',5'-di-*tert*-butyl-4'-hydroxyphenyl) propionate] methane.⁴

A1.3.3 *Xylene*, industrial-grade.

A1.3.4 *Sulfuric Acid-Potassium Dichromate Cleaning Solution*—To 35 mL of a saturated solution of potassium dichromate (K₂Cr₂O₇), carefully add 1 L of concentrated sulfuric acid (H₂SO₄).

A1.3.5 *Acetone*, reagent grade.

A1.4 Procedure

A1.4.1 *Decahydronaphthalene Preparation* —Distill in accordance with Test Method D 1061 and add 0.2 % tetrakis [methylene 3-(3',5'-di-*tert*-butyl-4'-hydroxyphenyl) propionate] methane.

A1.4.2 *Cleaning the Viscometer*—Clean the viscometer thoroughly with the cleaning solution, wash several times with distilled water, rinse with acetone, and purge with dry nitrogen.

A1.4.3 *Solution Preparation*—Dry the UHMW-PE in a vacuum oven for 2 h at 60°C. Weigh 14 to 17 mg of the dry UHMW-PE onto a slide cover slip. Use the buret to transfer the decahydronaphthalene at room temperature into the Erlenmeyer flask, measuring, in millilitres, a volume equal to 4.5 times the UHMW-PE weight in milligrams, for example, 15 mg of UHMW-PE and 67.5 mL of decahydronaphthalene. Heat the decahydronaphthalene, with stirring, to 150°C, and drop in the UHMW-PE and its slide cover slip. Continue stirring at 150°C for 1 h, with the flask lightly stoppered.

A1.4.4 *Viscosity Measurement:*

A1.4.4.1 Place the clean viscometer into the constant-temperature bath, fill with decahydronaphthalene, and allow the viscometer and solvent to come to thermal equilibrium at 135 ± 0.1°C. Determine the viscosity of the solvent. Remove the decahydronaphthalene with vacuum and wash the viscometer with 200 mL of warm (110 to 120°C) xylene. Remove with vacuum and aspirate dry air or nitrogen to dry the viscometer (2 or 3 min). It is essential that the whole viscometer be dry.

A1.4.4.2 Meanwhile, place the flask of polymer solution into the 135°C bath and allow it to equilibrate. Transfer sufficient solution to fill the viscometer to the mark (see Note A1.1) and determine the viscosity of the solution.

⁴ The antioxidant (Irganox® 1010) is available from American National Standards Institute, 25 W. 43rd St., 4th Floor, New York, NY 10036. Ciba-Geigy, Ardsley, NY.

A1.4.4.3 Between uses, clean the viscometer as described in A1.4.2. Prolonged waits between uses (overnight, etc.) will require the use of the H₂SO₄ – K₂Cr₂O₇ cleaning solution.

NOTE A1.1—Filling of the viscometer is made easier by the use of a glass funnel warmed with a heating mantle. This helps to prevent the UHMW-PE from precipitating.

A1.5 Calculation

A1.5.1 Calculate the relative solution viscosity as follows:

$$\eta_r = \frac{t_s - \frac{k}{t_s}}{t_o - \frac{k}{t_o}} \quad (A1.1)$$

$$\eta_r = \left(t_s - \frac{k}{t_s} \right) \left(t_o - \frac{k}{t_o} \right) \quad (A1.1)$$

where:

k = kinetic energy correction constant for the particular viscometer used,

t_s = flow time of solution at 135°C, and

t_o = flow time of pure solvent at 135°C.

APPENDICES

(Nonmandatory Information)

X1. IMPACT TEST METHOD FOR ULTRA-HIGH-MOLECULAR-WEIGHT POLYETHYLENE

X1.1 Scope

X1.1.1 This test method covers determination of the impact strength of UHMW-PE, which is extremely impact resistant. When tested in accordance with Test Method D 256, Method A, UHMW-PE generally gives the NBF type of failure, rendering the test result invalid. This test method specifies the same type of pendulum impact test machine as that given in Test Method D 256 but introduces a much higher degree of stress concentration into the specimen by double notching with a razor blade. Application of this test method shall be limited to the characterization of virgin, unmodified UHMW-PE resins, not commercially processed products. It is advised that the user be familiar with Test Method D 256 before attempting to use this test method.

X1.1.2 The values stated in SI units are to be regarded as the standard.

X1.1.3 *This standard does not purport to address all of the safety concerns, if any, associated with its use. It is the responsibility of the user of this standard to establish appropriate safety and health practices and determine the applicability of regulatory limitations prior to use.*

NOTE X1.1—There is currently no ISO standard that duplicates this test method. The impact strength of UHMW-PE is measured by a double-notched Charpy impact test in the pending ISO/CD 11542-2.

X1.2 Referenced Documents

X1.2.1 *ASTM Standards:*

D 256 Test Methods for Determining the Izod Pendulum Impact Resistance of Notched Specimens of Plastics²

X1.2.2 *ISO Standards:*³

ISO 180-1982 (E) Determination of Izod Impact Strength of Rigid Materials

ISO/CD 11542-2 Plastics—Ultra-High Molecular Weight Polyethylene (PE-UHMW) Moulding and Extrusion Materials—Part 2: Preparation of Test Specimens and Determination of Properties

X1.3 Apparatus

X1.3.1 The Izod-type impact machine that conforms to the requirements of Test Method D 256, including the calibration and checking methods, shall be used.

X1.4 Test Specimen

X1.4.1 The geometry and dimensions of the specimen are given in Fig. X1.1.

X1.4.2 The specimens shall be cut from a sheet compression molded under the following conditions:

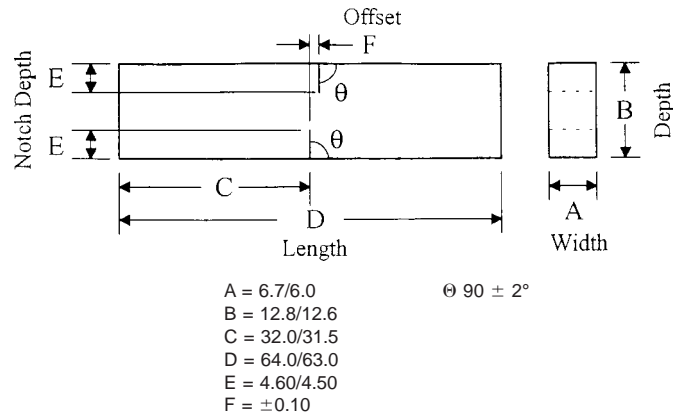

FIG. X1.1 Dimensions of Double-Notched Izod Test Specimens

Molding pressure	6.9 to 10.3 MPa
Platen temperature	196 to 210°C
Heating time	20 min at 196 to 210°C
Platen cooling rate	$15 \pm 2^\circ/\text{min}$ from 150 to 90°C
Platen temperature for demolding	$<30^\circ\text{C}$

X1.4.3 The width of the specimen shall be the thickness of the sheet if the sheet thickness is within 6.00 to 6.75 mm. Sheet material thicker than 6.75 mm shall be machined down to 6.35 ± 0.25 mm. Sheet material thicker than 7.65 mm shall not be used.

X1.4.4 Each specimen shall be free of twist and shall be bounded by mutually perpendicular pairs of plane parallel surfaces, free from scratches, pits, and sink marks.

X1.5 Notching of Specimens

X1.5.1 Notching shall be performed on the side parallel to the direction of the application of molding pressure.

X1.5.2 Notching shall be performed in a suitable machine by pressing in a 0.23 ± 0.03 -mm thick single-edge razor blade with a $14 \pm 2^\circ$ included angle at the cutting edge. The notching speed shall be less than 500 mm/min. A new blade shall be used after notching 40 specimens.

X1.5.3 The calibration of the notching machine shall be checked by direct measurement of the notch depth, perpendicularity, and offset of the two notches. One of the possible measurement methods is given in Appendix X2.

X1.6 Conditioning

X1.6.1 *Conditioning*— Condition the notched specimens at $23 \pm 2^\circ\text{C}$ and $50 \pm 5\%$ relative humidity for not less than 40 h prior to test.

X1.6.2 *Test Conditions*— Conduct the test in the standard laboratory atmosphere of $23 \pm 2^\circ\text{C}$ and $50 \pm 5\%$ relative humidity.

X1.7 Procedure

X1.7.1 At least five and preferably ten individual determinations of impact value must be made on each sample to be tested under the conditions prescribed in X1.6.

X1.7.2 Measure the width of each specimen in the region of the notches twice with a micrometer to the nearest 0.025 mm, and record its average width. Use an optical microscope to measure the distances between the notch roots on the two side surfaces of the specimen. Record the average value and multiply this number by the width of the specimen to obtain the remaining unnotched cross-section area, AR . Also record the identifying markings of the specimen.

X1.7.3 Estimate the breaking energy for the specimen and select a pendulum of suitable energy. Start the test with a pendulum of 11 J if no prior test data are available. Use the lightest standard pendulum that is expected to break each specimen in the group with a loss of not more than 85 % of its energy.

X1.7.4 Before testing the specimens, perform the following operations on the machine:

X1.7.4.1 With the excess energy indicating pointer in its normal starting position, but without a specimen in the vise, release the pendulum from its normal starting position and note the position that the pointer attains after the swing as one reading of Factor A .

X1.7.4.2 Without resetting the pointer, raise the pendulum and release again. The pointer should move up the scale an additional amount. Repeat this procedure until a swing causes no additional movement of the pointer, and note the final reading as one reading of Factor B .

X1.7.4.3 Repeat the above two operations several times, and calculate and record the average A and B readings.

X1.7.5 Position the specimen precisely and rigidly but not clamped too tightly in the vise. The relationship of the vise, specimen, and striking edge of the pendulum to one another is given in Fig. X1.2. Note that the top plane of the vise shall be 0.13 ± 0.13 mm below the notches.

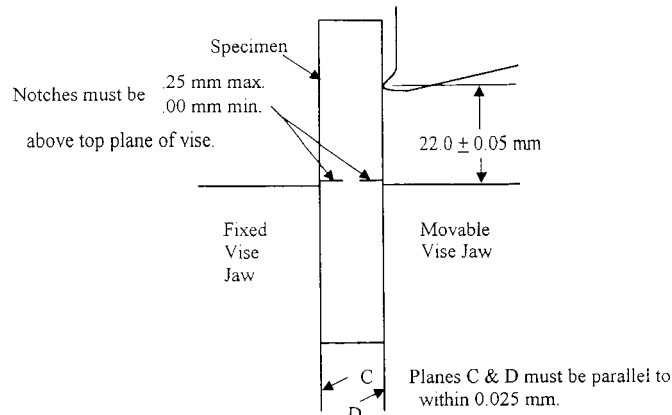

FIG. X1.2 Relationship of Vise, Specimen, and Strike Edge to One Another

X1.7.6 Release the pendulum and note and record the excess energy remaining in the pendulum after breaking the specimen.

X1.7.7 From the breaking strength of the specimen and Factors *A* and *B*, determine the energy loss of the pendulum due to windage and friction using the correction charts from the commercial testing machine supplier. If these charts are not available, use the method given in Appendix X2 or X3 of Test Method D 256. Subtract the correction so calculated from the indicated breaking strength of the specimen. If a pendulum of improper energy was used, discard the result and make additional tests on new specimens with the proper pendulum. If the proper pendulum was used, divide the net value so found by the unnotched area *AR* of the specimen as measured in X1.7.2 to obtain its impact strength in kilojoules per square metre.

X1.7.8 Record the type of failure for each specimen as one of the two coded categories defined as follows:

- (1) *C*, Complete Break—A break in which the specimen separates into two pieces.
- (2) *NB*, Non-Break—A break in which the specimen does not separate into two pieces.

X1.7.9 Calculate the average impact strength and standard deviation of the group of specimens that results in complete breakage. This test method requires that the specimen breaks completely. The results obtained from unbroken specimens shall be considered a departure from standard and shall not be reported as a standard result.

X1.8 Report

X1.8.1 Report the following information:

X1.8.2 Complete identification of the material tested, including type, source, manufacturer's lot number, and previous history;

X1.8.3 Compression molding conditions;

X1.8.4 Capacity of the pendulum, *J*;

X1.8.5 Total number of specimens tested;

X1.8.6 Number of those specimens that result in complete break;

X1.8.7 Average impact strength, kJ/m^2 ;

X1.8.8 Standard deviation; and

X1.8.9 Percent of specimens failing in each category, suffixed by the corresponding letter code from X1.7.8.

X1.9 Precision and Bias

X1.9.1 Table X1.1 is based on a round robin conducted by seven laboratories. For each material, all of the test specimens were compression molded and machined at one source. Each participating laboratory notched and tested five specimens of each material.

TABLE X1.1 Precision of the Double-Notched Izod Impact Test Method

Material	Intrinsic Viscosity, dl/g	Values, kJ/m^2				
		Mean	S_r^A	S_R^B	I_r^C	I_R^D
A	24	128.0	6.5	27.6	18.4	78.2
B	27	120.0	5.4	25.8	15.2	73.1
C	22	103.9	4.1	21.2	11.6	59.9
D	28	56.1	2.2	9.6	6.2	27.2
E	25	63.5	2.7	12.6	7.7	35.5

^A S_r = within-laboratory standard deviation of the average.

^B S_R = between-laboratories standard deviation of the average.

^C I_r = $2.83 S_r$

^D I_R = $2.83 S_R$.

X1.9.1.1 *Repeatability, I_r* (Comparing two test results for the same material, obtained by the same operator using the same equipment on the same day)—The two test results should be judged not equivalent if they differ by more than the I_r value for that material.

X1.9.1.2 *Reproducibility, I_R* (Comparing two test results for the same material, obtained by different operators using different equipment on different days)—The two test results should be judged not equivalent if they differ by more than the I_R value for that material.

X2. MEASUREMENT METHOD OF IMPERFECTIONS IN SPECIMEN NOTCHING

X2.1 The following is one of the possible test methods for measuring the imperfections in specimen notching directly, which can be classified into three kinds: (1) deviation from perpendicularity, (2) incorrect notch-depth, and (3) offset of notches (Fig. X2.1).

X2.2 Apparatus

X2.2.1 *Reflective Optical Microscope* , ocular, 40 to 60×, with an X-Y stage accurate to 0.0025 mm.

X2.2.2 *Eyepiece*, with a crosshair.

X2.2.3 *Fiber Optic Illumination* .

X2.3 Procedure

X2.3.1 Lay the specimen on one of its sides and mount it securely on the X-Y stage.

X2.3.2 The beginning and ending points of the notches are labeled from A to D in Fig. X2.1. Select one of the edges of the specimen as the datum line from which the perpendicularity of the notches to the edges is measured (in this case Line \overline{AE}). Note that Point E is approximately 6.4 mm from Point A.

X2.3.3 Both the microscope and the base of the X-Y stage should be stationary. Measure the coordinates of Points A to E with respect to an arbitrarily selected coordinate system by moving the X-Y stage and by targeting the points by the crosshair of the eyepiece.

X2.4 Calculation

X2.4.1 The following equation is used to calculate the perpendicularity of the notches:

$$\angle EAB = \tan^{-1} \frac{m_2 - m_1}{1 + m_2 m_1} \tag{X2.1}$$

where:

m_1 and m_2 = slopes of line \overline{AE} and \overline{AB} with respect to the coordinate system.

m_1 and m_2 are calculated from

$$m = \frac{y_2 - y_1}{x_2 - x_1} \tag{X2.2}$$

where:

m = slope, and

(x_1, y_1) and (x_2, y_2) = coordinates of the end points of the line.

The distance between two points, I , is obtained from the following equation:

$$I = \sqrt{(x_2 - x_1)^2 + (y_2 - y_1)^2} \tag{X2.3}$$

The amount of offset of the notches is calculated from the following equation:

$$\text{offset} = |AD| \cos \angle DAE \tag{X2.4}$$

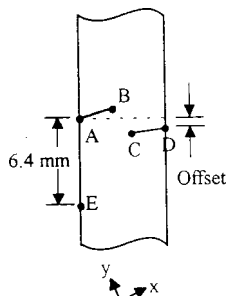

FIG. X2.1 Notch Geometry of Double-Notched Izod Specimen

X3. VISCOSITY AVERAGE MOLECULAR WEIGHT OF

X3. ELONGATIONAL STRESS TEST METHOD FOR ULTRA-HIGH MOLECULAR-WEIGHT POLYETHYLENE

X3.1 Scope

X3.1.1 This test method covers the determination of molecular weight elongational stress as a characterization of UHMW-PE is nearly impossible to measure by techniques normally used to measure molecular weight the melt viscosity of other polymers. Techniques such as gel permeation chromatography (GPC) and light scattering used for other polymers are not useful for UHMW-PE.

X3.1.2 The dilute viscosity UHMW-PE. The melt flow rate in accordance with test method may provide satisfactory correlations D 1238 cannot be determined for viscosity average this material because ultra high molecular weight within polyethylene does not have a specific manufacturing process, but melt flow. The elongational stress may also be referred to as ZST and flow value, or both.

X3.1.2 Application of this test method shall be limited to virgin, unmodified resin. The elongational stress method is invalid on a previous thermally-processed material due to possible crosslinking.

X3.1.3 This standard does not purport to address all of the safety concerns, if any, associated with its use. It is the responsibility of the user of this standard to establish appropriate safety and health practices, and determine the applicability of regulatory limitations prior to use.

X3.2 Referenced Documents

X3.2.1 ASTM Standards:

D 4703 Practice for a Compression Molding Thermoplastic Materials into Test Specimens, Plaques, or Sheets⁵

X3.2.2 ISO Standards:

ISO 11542-2 Plastics – Ultra-high-molecular-weight polyethylene (PE-UHMW) Moulding and Extrusion – Part 2: Preparation of test specimens and determination of properties

X3-A3. Terminology

X3.3.1 elongational stress— (in MPa) the tensile stress (force related to the initial cross-sectional area) required to elongate a result; test specimen 600 % in a hot oil bath at least five equations have been developed to describe 150°C in a 10-min time period.

X3.3.2 tensile stress— (in MPa) the molecular attached weight of UHMW-PE.

X3.1.3 Fig. X3.1 shows corrected for the relationship between buoyancy effect divided by the five equations measured initial cross-sectional area.

X3.4 Apparatus

X3.4.1 Specimen die cutter

X3.4.2 Specimen holder in accordance with respect to viscosity average molecular Fig. X3.1

X3.4.3 Constant temperature bath with thermoregulator and circulating pump

X3.4.4 Graduated weight versus intrinsic viscosity.

X3.1.4 This appendix is being provided only as set with hooks for suspension from the specimen holder. These weights should be approximately 700, 650, 600, 550, 500, 450, 400, 350, 300, 250, 200, 180, 150, 120, and 100 g.

X3.4.5 Measuring instrument capable of measuring to 0.02 mm

X3.4.6 Stopwatch

X3.4.7 Hot bath liquid (for example, silicone oil)

X3.4.8 Compression molding press with controlled rate of cooling of $15 \pm 2^\circ\text{C}/\text{min}$

X3.4.9 Positive compression mold with a reference. Only Eq 1 listed in 3.2.1.1 minimum of this specification shall be used 4 grooves for venting and minimization of residual stress and warpage. Capable of molding plaque or disk 1.4 mm in thickness.

⁶ The antioxidant (Irganox® 1010) is available from Ciba-Geigy, Ardsley, NY.

⁵ Annual Book of ASTM Standards, Vol 08.03.

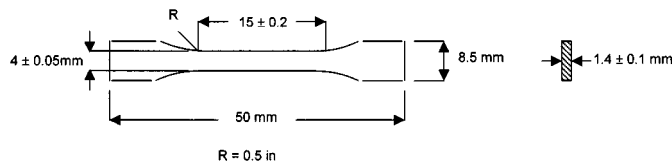

R = 0.5 in
FIG. X3.1 Test Specimen

X3.4.10 Aluminum foil

X3.4.11 Analytical balance, accurate to present data to the industry.

X4. ABRASION INDEX OF UHMWPE USING AN ALUMINUM OXIDE SLURRY ± 0.1 g

X3.4.12 Blender, high intensity

X3.5 Reagents

X3.5.1 The addition of a mixture of a primary and secondary antioxidant to reduce the amount of crosslinking taking place in the specimens. The type and amount of antioxidant used will depend on the lab and the R^2 value observed when results are calculated.

NOTE X3.1—Irganox B215 or B225 have been found to work well when added at between 0.4 and 0.75 % by weight.⁶

X3.6 Procedure

X3.6.1 Test Plaque Preparation:

X3.6.1.1 Using the analytical balance weigh out the amount of UHMW-PE virgin material that will be needed to mold the number of plaques or disks required for the study. Based on the amount of UHMW-PE weighed, weigh the amount of antioxidant necessary to achieve a concentration capable of reducing crosslinking. With the high intensity blender, mix the antioxidant homogeneously into the UHMW-PE.

X3.6.1.2 Place the bottom half of the positive compression mold on a flat surface. Cover the bottom half with a piece of aluminum foil. Weigh out the amount of the UHMW-PE/antioxidant mix necessary to fill the mold, make a full part, and minimize flash and warpage. When this weight is established, this weight ± 0.1 g shall be used consistently to ensure uniform moldings. Pour the weighed polymer into the mold cavity and spread it out into a smooth level surface. Cover with a second piece of aluminum foil, then the upper portion of the positive compression mold.

X3.6.1.3 A completely fused test plaque is prepared by compression molding. The following molding conditions are proposed as guidelines: 1) 200°C under 12.7 MPa pressure for 20 min, 2) cool under pressure at a cooling rate of $15 \pm 2^\circ\text{C}/\text{min}$ and 3) when the plaque or disk has cooled to below 40°C, remove it from the mold.

X3.6.2 Test Specimens

Six specimens in accordance with Fig. X3.2 shall be die cut out of one test plaque. Each specimen is tested using a different weight as described in X3.6.4.4.

X3.6.3 Measurement of Cross-sections

The width and thickness at the narrow parallel-sided section of each of the six specimens shall be measured and recorded to the nearest 0.02 mm.

X3.6.4 Elongational Stress Determination

X3.6.4.1 Stabilize the bath at $150 \pm 2^\circ\text{C}$.

X3.6.4.2 Insert test specimen in the holder, hook the corresponding weight to the holder and suspend in bath. The mass of the holder and weights shall be known to an accuracy of 0.1 g.

X3.6.4.3 After preheating five min, elongate specimen and record specimen elongation time. The elongation of test specimens does not take place at constant speed.

X3.6.4.4 Repeat for the remaining specimens. The choice of the six different weights used to load test specimens from the weights listed in X3.4.4 depends upon the molecular weight of the UHMW-PE sample. The weights shall be selected so that a time of 1 to 20 min gives 600 % elongation in the narrow parallel-sided section of the test specimen.

X3.7 Calculation

X3.7.1 The tensile stress in MPa on each individual specimen is calculated in accordance with the following equation:

$$T_s = \{(M_1 + M_2) \times 0.00981\} / A_1 \times B_1 \times [1 - (\rho_m / \rho_w)] \quad (X3.1)$$

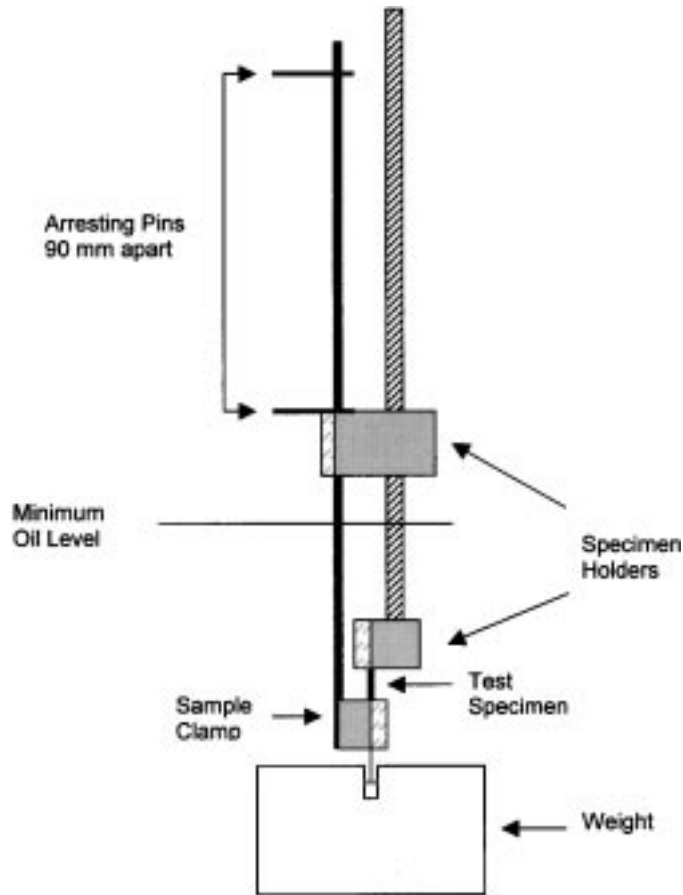

FIG. X3.2 Specimen Holder

- T_s ≡ Tensile stress in MPa
- M_l ≡ Mass of selected weight
- M_2 ≡ Mass of specimen holder
- A_l ≡ Initial thickness of test specimen (mm)
- B_l ≡ Initial width of test specimen (mm)
- ρ_m ≡ Density of the heat bath medium at 150°C
- ρ_w ≡ Density of the metal at 150°C

Use log/log scale to plot tensile stress for the six specimens against corresponding times for the 600 % elongation recorded in X3.6.4.4. Draw a best fit line through the six points and from this graph, read off the tensile stress corresponding to a period of 10 min. This value represents the elongational stress in MPa.

NOTE X3.2—An undue amount of scatter ($R^2 \leq 0.95$) or zero elongation indicates that crosslinking has occurred in the test specimens. The test should be repeated using specimens prepared using an increased amount of stabilizer. Increase the stabilizer level at least 50 % from what was previously used.

X3.8 Precision

X3.8.1 The repeatability standard deviation has been determined to be 0.009 MPa for a material having an average elongational stress value of 0.516 MPa. This is based on a single laboratory making 45 measurements over a period of time on one material. The reproducibility of this test method is not yet available.

X4. VISCOSITY AVERAGE MOLECULAR WEIGHT OF ULTRA-HIGH MOLECULAR-WEIGHT POLYETHYLENE

X4.1 Scope

X4.1.1 The measurement of molecular weight of UHMW-PE is nearly impossible to measure by techniques normally used to measure molecular weight of other polymers. Techniques such as gel permeation chromatography (GPC) and light scattering used for other polymers are not useful for UHMW-PE.

X4.1.2 The dilute viscosity test method may provide satisfactory correlations for viscosity average molecular weight within a specific manufacturing process, but may not apply for another manufacturing process. As a result, at least five equations have been developed to describe the molecular weight of UHMW-PE.

X4.1.3 Fig. X4.1 shows the relationship between the five equations with respect to viscosity average molecular weight versus intrinsic viscosity.

X4.1.4 This appendix is being provided only as a reference. Only Eq 1 listed in 3.2.1.1 of this specification shall be used to present data to the industry.

X5. ABRASION INDEX OF UHMWPE USING AN ALUMINUM OXIDE SLURRY

X5.1 Scope

X5.1.1 This method is used to determine the resistance of materials to abrasion, measured in terms of percent weight loss, by rotating test specimens in a slurry consisting of 20 grit aluminum oxide and water.

X5.1.2 The values stated in SI units are to be regarded as the standard. The values given in parentheses are for information only.

X5.1.3 This standard does not purport to address all of the safety concerns, if any, associated with its use. It is the responsibility of the user of this standard to establish appropriate safety and health practices and determine the applicability of regulatory limitations prior to use.

X5.2 Referenced Documents

X5.2.1 ASTM Standards:

D 618 Practice for Conditioning Plastics and Electrical Insulating Materials for Testing²

D 883 Terminology Relating to Plastics²

D 1921 Test Methods for Particle Size (Sieve Analysis) of Plastic Materials²

D-1928 Practice 4703 Practice for Preparation of Compression-Molded Polyethylene Compression Molding Thermoplastic Materials into Test Specimens, Plaques, or Sheets and Test Specimens²⁵

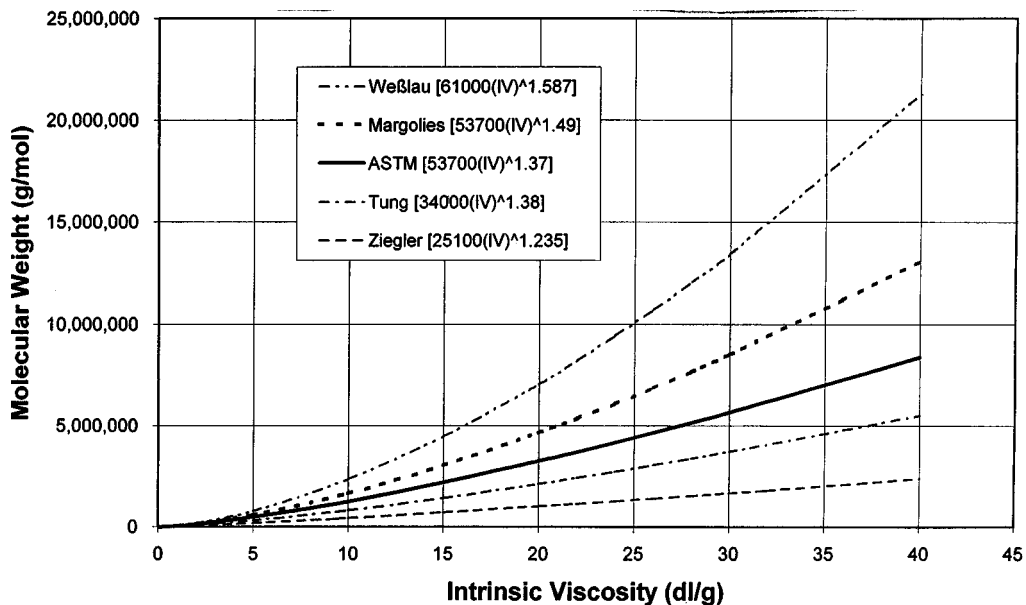

FIG. X34.1 Known Molecular Weight Equations (Correlating with Intrinsic Viscosity)

E 691 Practice for Conducting an Interlaboratory Study to Determine the Precision of a Test Method⁷

X45.3 Terminology

X45.3.1 *Definitions*— For definitions related to plastics, see Terminology D 883.

X45.4 Apparatus

X45.4.1 *Abrasion tester*, consisting of:

X45.4.1.1 *Motor*—capable of maintaining a uniform rotational speed of 1750 rpm.

X45.4.1.2 *Stainless steel testing cups* —140 mm (5.5 in.) deep and 102 mm (4 in.) inside diameter, for holding specimens and aluminum oxide slurry.

X45.4.1.3 *Stainless steel (SS) shafts* —9 mm outside diameter.

X45.4.1.4 *Metal cup supports*—with dimensions of 3.2 mm by 51 mm by 152 mm (1/8 in. by 2 in. by 6 in.)

X45.4.1.5 *Thermocouple*— positioned in the testing cup to monitor slurry temperature.

X45.4.1.6 *Gaskets*—fitted into groove at the top of each testing cup to prevent leaking of slurry during motor rotation.

X45.4.1.7 *Water bath*— plastic glass container having dimensions of 55 by 53 by 20 cm. Contains the water to cool the testing cups during operation.

X45.4.1.8 *Hydraulic jack*— for raising the water bath up under the testing cups.

X45.4.1.9 *Control panel*— consisting of a timing device for automatic test termination after 2 h and other controls.

X45.4.1.10 *Water chiller*— to maintain the water bath at $23 \pm 2^\circ\text{C}$.

X45.4.1.11 *Thermocouple*— to verify the temperature of the water bath.

X45.4.2 *Analytical balance*—for weighing test specimens, accurate to 0.0001 g.

X45.4.3 *Pan balance*— with approximately a 1000 g capacity for preparation of slurry.

X45.4.4 *Vented rack*— for air-drying specimens, to allow for free circulation of air.

X45.5 Reagents

X45.5.1 *Aluminum Oxide (Al_2O_3)*—20 grit

NOTE X45.1—Perform incoming inspection on every lot of aluminum oxide received by pulling an approximate 50-g sample from every fifth bag or box of the lot. Perform a particle size analysis in accordance with Test Methods D 1921 using the following sieve sizes: 12, 16, 18, 20, 25, and pan. The specification for the aluminum oxide shall be as specified in Table X45.1

X45.6 Test Specimen

X45.6.1 Test specimen sheets prepared from powder or pellets shall be 6.4 ± 0.64 mm (0.25 ± 0.025 in.) thick and molded in accordance with Procedure C of Annex A1 of Practice D 1928.

~~X4.6.2 Test D 4703.~~

X5.6.2 Test specimens (Fig. X45.1) are machined from the sheets. Dimensions of the test specimens shall be 69.85 ± 0.64 mm by 25.4 ± 0.64 mm by 6.35 ± 0.64 mm (2.75 ± 0.025 in. by 1.00 ± 0.025 in. by 0.25 ± 0.025 in.). Each specimen has a large and a small hole; 8.7 mm ($1\frac{1}{32}$ in.) diameter and 3.6 mm ($\frac{9}{64}$ in.) diameter drill bits, respectively.

X45.7 Conditioning

X45.7.1 All specimens shall be conditioned in accordance with Practice D 618, unless otherwise specified.

X45.8 Test Procedure

X45.8.1 Weigh each specimen to the nearest 0.0001 g and record this weight at W1. A minimum of two specimens per sample shall be tested.

⁷Supporting data are available from

⁷ Annual Book of ASTM Headquarters. Request RR- D20-1212. Standards, Vol 14.02.

TABLE X45.1 SPECIFICATION FOR ALUMINUM OXIDE

USA Standard Sieve Number (mm)	Tyler Equivalent Number	Sieve Opening (μm)	Specification Percent Retained
1.70	12	1700	0
1.18	16	1180	20 max
1.00	18	1000	45 min
Contents of 18 + 20 mesh screens—contents of 16 mesh			70 min
PAN	screen PAN	=	3 max

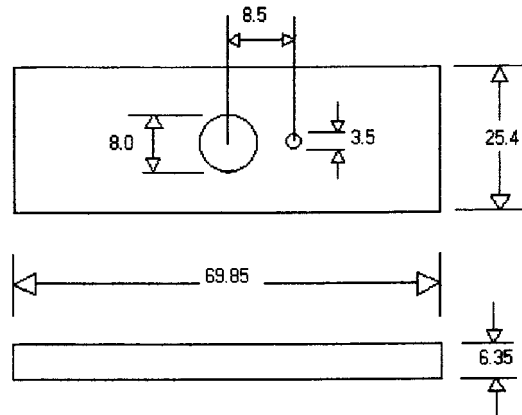

Abrasion Specimen

	Nominal Specimen dimensions	
	mm	in.
length	69.85	2.75
width	25.4	1.0
thickness	6.35	0.25
large hole diameter	8.0	0.32
small hole diameter	3.5	0.14

FIG. X45.1 Abrasion Test Specimen Dimensions

X45.8.2 Using the pan balance and tared plastic cups, weigh out in separate cups, 450 g of aluminum oxide and 300 g of water. Pour the contents of each cup into the stainless steel testing cup. Repeat procedure for each of the stainless steel testing cups on the unit until all cups contain the aluminum oxide/water mixture.

X45.8.3 Attach the specimens to the stainless steel shafts of the abrasion. Bolt the specimens to the shaft. Do not overtighten the bolts as this will stress the specimen.

X45.8.4 Inspect the gasket in each testing cup to insure it is clean and properly positioned in the groove.

X45.8.5 Push the testing cup upwards, rotating slightly so the specimen is fully immersed in the aluminum oxide/water mixture.

X45.8.6 Move the metal cup support under the cup. Push the support tightly against the cup. Tighten the wing nuts evenly. If not even, the cup may rotate or tilt, leading to splattering of the aluminum oxide and result in greater specimen wear.

X45.8.7 Set the time to 120 min.

X45.8.8 Raise the hydraulic jack so approximately the bottom one-third of each testing cup is immersed in the water bath. Turn on the water chiller.

X45.8.9 Turn on the main power and push the start button to begin the test.

X45.8.10 When the test unit has shut off at the end of 2 h, turn off the main power and the water chiller. Lower the water bath so the testing cups are no longer immersed. Unscrew the wing nuts from each testing cup and remove the metal cup support. Remove each specimen from the shaft.

X45.8.11 Using your fingernail, carefully remove any melted material that may be attached to the specimen.

X45.8.12 Clean the specimens with water and a brush, and allow them to air-dry for a minimum of 2 h on the vented rack. Insure that no water droplets are inside either of the two holes.

X45.8.13 Reweigh the specimens and record this weight as W2.

X45.9 Calculation

X45.9.1 Calculate the percent of weight loss using the following equation:

$$\% \text{ weight loss} = [(W1 - W2)/W1] \times 100 \quad (X5.1)$$

Where:

W1 = original weight of test specimen

W2 = weight of test specimen after test

X45.10 Report

X45.10.1 Report the following information:

X45.10.1.1 Complete identification and description of the material tested, including source and manufacturer's code,

X45.10.1.2 Method of sample preparation,

X45.10.1.3 Conditioning of specimens prior to testing,

X45.10.1.4 Length of abrasion time, if other than 120 min,

X45.10.1.5 Specimen number, initial weight of specimen (W1), final weight of specimen after abrasion (W2), and

X45.10.1.6 Percent abrasion for each specimen and average percent abrasion for the sample. Report three significant figures.

X45.11 Precision and Bias

X45.11.1 Table X45.2 is based on a round robin⁸ conducted in 1999 in accordance with Practice E 691, involving four materials tested by three laboratories. For each material, all samples were prepared at one source, but the individual specimens were prepared at the laboratories which tested them. Each test result was the result of six individual determinations. Each laboratory obtained 12 test results for each material.

NOTE X45.2—**Caution:** The explanations of “r” and “R” (X45.11.2-X45.11.2.3) are only intended to present a meaningful way of considering the approximate precision of this test method. The data in Table X45.2 should not be applied to acceptance or rejection, as these data apply only to the materials tested in the round robin and are unlikely to be rigorously representative of other lots, formulations, conditions, materials, or laboratories. Users of this test method should apply the principles outlined in Practice E 691 to generate data specific to their materials and laboratory (or between specific laboratories). The principles of X45.11.2-X45.11.2.3 would then be valid for this data.

X45.11.2 *Concept of “r” and “R” in Table X45.2*—If S_r and S_R have been calculated from a large enough body of data, and for test results that were averages from testing 6 specimens for each test result, then:

X45.11.2.1 *Repeatability*—Two results obtained within one laboratory shall be judged not equivalent if they differ by more than the “r” value for the material (“r” is the interval representing the critical difference between two test results for the same material, obtained by the same operator using the same equipment on the same day in the same laboratory).

X45.11.2.2 *Reproducibility*—Two test results obtained by different laboratories shall be judged not equivalent if they differ by more than the “R” value for that material (“R” is the interval representing the critical difference between two test results for the same material, obtained by different operators using different equipment in different laboratories).

X45.11.2.3 Any judgement in accordance with X45.11.2.1 or X45.11.2.2 would have an approximate 95 % (.95) probability of being correct.

X45.11.3 There are no recognized standards by which to estimate bias of this method.

Annual Book of

⁸ Supporting data are available from ASTM Standards, Vol 09.01, Headquarters, Request RR: D20-1212.

X56. PROPERTIES AND TEST CONDITIONS FOR UHMW-PE

X56.1 Table X56.1 is a listing of test methods that can be used to characterize UHMW-PE.

X56.2 Referenced Documents

X56.2.1 *ASTM Standards:*

C 1444 Test Method for Measuring the Angle of Repose of Free-Flowing Mold Powders⁹

⁹ Annual Book of ASTM Standards, Vol 08.02, 15.01.

TABLE X45.2 PRECISION DATA, ABRASION INDEX

Material	Average	Values expressed in Units of %			
		S_r^A	$S_R^{B,C}$	r^D	$R^{E,C}$
M-19 IV	2.68	0.12	0.25	0.32	0.69
M-28 IV	2.47	0.16	0.20	0.45	0.55
T-20 IV	2.43	0.16	0.21	0.46	0.59
T-28 IV	2.25	0.10	0.25	0.27	0.71

^A S_r = Within laboratory standard deviation for the indicated material. It is obtained by pooling the within-laboratory standard deviation of the test results from all of the participating laboratories:

$$S_r = \left[\frac{(S_1)^2 + (S_2)^2 + \dots + (S_n)^2}{n} \right]^{1/2}$$

^B S_R = between-laboratories reproducibility, expressed as standard deviation:

$$S_R = [S_r^2 + S_r^2]^{1/2}$$

Where

S_r = standard deviations of laboratory means.

^CThe calculated S_R and R values in the table are based on data from three laboratories, which is insufficient to provide complete statistical data. However, S_R and R are provided for information only and should not be used in the normal manner.

$$^D r = \text{within-laboratory critical interval between two test results} = 2.8 \times S_r$$

$$^E R = \text{between-laboratories critical interval between two test results} = 2.8 \times S_R$$

- D 256 Test Method for Determining the Izod Pendulum Impact Resistance of Notched Specimens of Plastics²
- D 635 Test Method for Rate of Burning and/or Extent and Time of Burning of Self-Supporting Plastics in a Horizontal Position²
- D 638 Test Method for Tensile Properties of Plastics²
- D 648 Test Method for Deflection Temperature of Plastics Under Flexural Load²
- D 790 Test Methods for Flexural Properties of Unreinforced and Reinforced Plastics and Electrical Insulating Materials²
- D 792 Test Methods for Density and Specific Gravity (Relative Density) of Plastics by Displacement²
- D 1894 Test Method for Static and Kinetic Coefficients of Friction of Plastic Film and Sheeting²
- D 1895 Test Methods for Apparent Density, Bulk Factor, and Pourability of Plastics Materials²
- D 2240 Test Method for Rubber Property—Durometer Hardness¹⁰
- D 2951 Test Method for Resistance of Types III and IV Polyethylene Plastics to Thermal Stress-Cracking¹¹
- E 313 Practice for Calculating Yellowness and Whiteness Indices from Instrumentally Measured Color Coordinates¹²
- X56.2.2 *ISO Standards*.³
- ISO 62 Plastics—Determination of Water Absorption
- ISO 527-1 Determination of tensile Properties, Part 1 General Principles
- ISO 868 Plastics and Ebonite—Determination of Indentation Hardness by Means of a Durometer (Shore Hardness)
- ISO 1183 A Plastics—Methods for Determining the Density and Relative Density of Non-cellular Plastics
- ISO 1628-3 Plastics—Determination of Viscosity Number and Limiting Viscosity Number—Part 3: Polyethylenes and Polypropylenes
- ISO 3146 Plastics—Determination of Melting Behavior (Melting Temperature or Melting Range) of Semicrystalline Polymers
- ISO 8295 Plastics—Film and Sheeting—Determination of Coefficients of Friction
- ISO 10350 Plastics—Acquisition and presentation of Comparable Single-Point Data
- ISO 11542-2 Plastics—Ultra High Molecular-Weight Polyethylene (PE-UHMW) Moulding and Extrusion Materials—Part 2: Preparation of Test Specimens and determination of Properties
- X56.2.3 *IEC Standards*³
- IEC 93 Recommended Methods of Test for Volume and Surface Resistivities of Electrical Insulating Materials
- IEC 112 Recommended Method for Determining the Comparative Tracking Index of Solid Insulation Materials
- IEC 243-1 Recommended Methods of Test for Electric Strength of Solid Insulating Material at Power Frequencies
- IEC 250 Recommended Methods for Determination of the Permittivity and Dielectric Dissipation Factor of Electrical Insulation Materials at Power, Audio, and Radio Frequencies Including Metre Wavelengths
- IEC 60695-11-10 Fire Hazard Testing, Part 11-10 Test Flames 50 W Horizontal and Vertical Flames

TABLE X6.1 Test Methods Used to Characterize UHMW-PE

Properties	Standard	Specimen Type and Dimensions (mm)	Units	Test Conditions and Supplementary Instructions
<i>Rheological</i>				
<u>Intrinsic Viscosity</u>	<u>Specification D 4020, Annex A1</u>	<u>Granules or powder</u>		<u>Relative viscosity at 0.02 % concentration in decalin</u>
<i>Mechanical Properties</i>				
<u>Tensile Stress at Yield</u>	<u>Test Method D 638 and ISO 527-1</u>	<u>Test Method D 638, Type 4</u>	<u>MPa</u>	<u>50 mm/min</u>
<u>Tensile Stress at Break</u>		<u>ISO 527-1, Type 2</u>	<u>MPa</u>	
<u>Tensile Elongation at Yield</u>			<u>%</u>	
<u>Tensile Elongation at Break</u>			<u>%</u>	<u>Measured when extensometer is used</u>
<u>Nominal Strain at Break</u>			<u>%</u>	<u>Gage length is equal to grip distance</u>
<u>Tensile Modulus</u>			<u>MPa</u>	<u>ASTM 5 mm/min, 2 % secant modulus ISO 1 mm/min, chord modulus between 0.05 % and 0.25 % strain</u>
<u>Elongational Stress</u>	<u>Specification D 4020, Appendix X4</u>	<u>Specimen specified in Appendix X4</u>		
<u>Flexural Modulus</u>	<u>Test Methods D 790</u>	<u>127 by 12.7 by 6.35</u>	<u>MPa</u>	<u>1 % secant, 101.6 mm span, 28 mm/min crosshead speed</u>

¹⁰ Annual Book of ASTM Standards, Vol 069.01.

¹¹ This specification is under the jurisdiction of ASTM Committee D20 on Plastics and is the direct responsibility of Subcommittee D20.15 on Thermoplastic Materials

Current edition approved November 10, 2001. Published January 2002. Originally published as D 4020 – 81. Last previous edition D 4020 – 01.

¹² Annual Book of ASTM Standards, Vol 06.01.

TABLE X6.1 *Continued*

<u>Double Notched Izod Impact Resistance</u>	<u>Specification D 4020, Appendix X1 and Appendix X2</u>	<u>63.5 by 12.7 by 6.35</u>	<u>kJ/m²</u>	
<u>Izod Impact Resistance</u>	<u>Test Method D 256</u>	<u>63.5 by 12.7 by 6.35</u>	<u>J/m</u>	
<u>Charpy Impact Resistance</u>	<u>ISO 11542-2, Annex B</u>	<u>120 by 15 by 10</u>	<u>KJ/m²</u>	
<u>Hardness</u>	<u>Test Method D 2240, ISO 868</u>	<u>13 by 13 by 6.35 mm</u>	<u>D</u>	<u>Reading taken after 15 s</u>
<u>Thermal Properties</u>				
<u>Deflection Temperature under Flexural Load</u>	<u>Test Methods D 648</u>	<u>127 by 12.7 by 6.35</u>	<u>°C</u>	<u>0.454 MPa stress, 0.25 mm deflection, 2°C/min heating rate</u>
<u>Thermal Stress Cracking</u>	<u>Test Methods D 2951</u>	<u>125 × 6.4 × 1.25</u>	<u>h</u>	<u>6.4 mm diameter mandrels at 100°C</u>
<u>Melting Temperature</u>	<u>ISO 3146</u>	<u>powder</u>	<u>°C</u>	<u>Method C, ramp rate 10°C/min</u>
<u>Coefficient of Linear Expansion</u>	<u>ISO 10350</u>	<u>Cut from ISO 3167 multipurpose bar</u>	<u>1/°C</u>	<u>TMA, secant value over the temperature range of +23°C to +55°C</u>
<u>Flammability</u>	<u>Test Method D 635, IEC 60695-11-10</u>	<u>125 by 13 by 3</u>	<u>mm/min</u>	<u>Linear burning rate of specimens in horizontal position</u>
<u>Performance Properties</u>				
<u>Abrasion Index</u>	<u>Specification D 4020, Appendix X5</u>	<u>69.8 by 25.4 by 6.35</u>	<u>%</u>	<u>1750 RPM, 2 h in aluminum oxide/water slurry</u>
<u>Electrical Properties</u>				
<u>Relative permittivity</u>	<u>IEC 250</u>	<u>>60 by >60 by 1</u>		<u>Frequency 100 Hz and 1 MHz (compensate for electrode edge effect)</u>
<u>Dissipation factor</u>	<u>IEC 250</u>	<u>>60 by >60 by 1</u>		<u>Frequency 100 Hz and 1 MHz (compensate for electrode edge effect)</u>
<u>Volume resistivity</u>	<u>IEC 93</u>	<u>>60 by >60 by 1</u>	<u>Ω-m</u>	<u>Voltage 100 V</u>
<u>Surface resistivity</u>	<u>IEC 93</u>	<u>>60 by >60 by 1</u>	<u>Ω</u>	<u>Voltage 100 V</u>
<u>Dielectric (Electrical) Strength</u>	<u>IEC 243-1</u>	<u>>60 by >60 by 1</u> <u>>60 by >60 by 3</u>	<u>KV/mm</u>	<u>Use 25 mm/75 mm coaxial-cylinder electrode configuration. Immerse in IEC 296 transformer oil. Use short time (rapid rise) test</u>
<u>Comparative Tracking Index (CTI)</u>	<u>IEC 112</u>	<u>>15 by >15 by 4</u>		<u>Use solution A</u>
<u>Miscellaneous Properties</u>				
<u>Density</u>	<u>Test Methods D 792, ISO 1183</u>	<u>50 by 12.7 by 6.35 (ASTM)</u> <u>10 by 10 by 4 (ISO)</u>	<u>g/cm³</u>	<u>Density by displacement</u>
<u>Bulk Density</u>	<u>Test Methods D 1895</u>	<u>Granules or powder</u>	<u>g/cm³</u>	
<u>Pourability</u>	<u>Test Methods D 1895</u>	<u>Granules or powder</u>	<u>S</u>	<u>Method A, tap funnel to start flow</u>
<u>Angle of Repose</u>	<u>Test Method C 1444</u>	<u>Granules or powder</u>	<u>Angle in degrees</u>	
<u>Coefficient of Friction</u>	<u>Test Method D 1894, ISO 8295</u>	<u>63.5 by 63.5 by 6.35</u>		<u>UHMW-PE against metal</u>
<u>Water Absorption</u>	<u>ISO 62</u>	<u>50 by 50 by 3 or 50 dia. by 3 disc</u>	<u>%</u>	<u>24 h immersion</u>
<u>Yellowness Index</u>	<u>Practice E 313</u>	<u>50 by 50 by 6.35</u>		<u>2 degree observer, Illuminant C, specular included, UV included, hemispherical configuration</u>

SUMMARY OF CHANGES

This section identifies the location of selected changes to this specification. For the convenience of the user, Committee D20 has highlighted those changes that may impact the use of this specification. This section may include descriptions of the changes or reasons for the changes, or both.

D 4020 – 00:

- (1) Added Note 1, ISO equivalency statement.
- (2) In 1.4, changed relative viscosity from 2.30 to 1.44.
- (3) In 3.2.1, changed relative viscosity from 2.30 to 0.05 % concentration to 1.44 at a concentration of 0.02 % for polymer in solvent.

D 4020 – 00a:

- (1) Changed “can” to “shall” in 3.2.1.1
- (2) Changed “weight” to “viscosity” in 3.2.1.1

- (3) Changed “nominal molecular weight” to “nominal viscosity molecular weight” in the equations in 3.2.1.1.
- (4) Add Note 2 in 3.2.1.1.
- (5) Changed “0.05 g” to “0.02 g” in A1.1.1.
- (6) Changed “35 to 43” to “14 to 17”, “1.8” to “4.5”, “36” to “15,” and “64.8” to “67.5” in A1.4.3. Changes made to achieve correct concentration.
- (7) Added Appendix-~~X3~~ X4 covering UHMWPE molecular weight.
D 4020 – 01:
 - (1) Added Appendix-~~X4~~ X5 and Appendix X6.
D 4020 – 01a:
 - (1) Added Appendix X3.
 - (2) Referenced documents updated to account for all test methods specified in Appendix X5.
 - (3) Added 6.3 Pourability and 6.4 Angle of Repose to Table X5.1.

ASTM International takes no position respecting the validity of any patent rights asserted in connection with any item mentioned in this standard. Users of this standard are expressly advised that determination of the validity of any such patent rights, and the risk of infringement of such rights, are entirely their own responsibility.

This standard is subject to revision at any time by the responsible technical committee and must be reviewed every five years and if not revised, either reapproved or withdrawn. Your comments are invited either for revision of this standard or for additional standards and should be addressed to ASTM International Headquarters. Your comments will receive careful consideration at a meeting of the responsible technical committee, which you may attend. If you feel that your comments have not received a fair hearing you should make your views known to the ASTM Committee on Standards, at the address shown below.

This standard is copyrighted by ASTM International, 100 Barr Harbor Drive, PO Box C700, West Conshohocken, PA 19428-2959, United States. Individual reprints (single or multiple copies) of this standard may be obtained by contacting ASTM at the above address or at 610-832-9585 (phone), 610-832-9555 (fax), or service@astm.org (e-mail); or through the ASTM website (www.astm.org).