



Designation: D 5934 – 96

Standard Test Method for Determination of Modulus of Elasticity for Rigid and Semi-Rigid Plastic Specimens by Controlled Rate of Loading Using Three-Point Bending¹

This standard is issued under the fixed designation D 5934; the number immediately following the designation indicates the year of original adoption or, in the case of revision, the year of last revision. A number in parentheses indicates the year of last reapproval. A superscript epsilon (ϵ) indicates an editorial change since the last revision or reapproval.

1. Scope

1.1 This test method covers the use of controlled rate of loading mechanical instrumentation for gathering and reporting the modulus of elasticity of thermoplastic and thermosetting resins and composite systems in the form of rectangular bars molded directly or cut from sheets, plates, or molded shapes. The data generated, using three-point bending techniques, may be used to identify the thermomechanical properties of a plastics material or composition using a controlled rate of loading mechanical instrument.² Results obtained from this test method may or may not be comparable to results obtained using D 790.

1.2 This test method is intended to provide a means for determining the modulus of elasticity within the linear region of the stress-strain curve (see Fig. 1). This test is conducted at standard temperature and pressure.

1.3 Apparent discrepancies may arise in results obtained under differing experimental conditions. These apparent differences from results observed in another study can usually be reconciled, without changing the observed data, by reporting in full (as described in this test method) the conditions under which the data were obtained.

1.4 The values stated in SI units are to be regarded as the standard. The values stated in parentheses are for information only.

1.5 *This standard does not purport to address all of the safety concerns, if any, associated with its use. It is the responsibility of the user of this standard to establish appropriate safety and health practices and determine the applicability of regulatory limitations prior to use.*

NOTE 1—There is no similar or equivalent ISO standard.

2. Referenced Documents

2.1 ASTM Standards:

D 618 Practice for Conditioning Plastics and Electrical

¹ This test method is under the jurisdiction of ASTM Committee D-20 on Plastics and is the direct responsibility of Subcommittee D20.10 on Mechanical Properties. Current edition approved Nov. 10, 1996. Published May 1997.

² This apparatus is available from the Perkin-Elmer Corporation, 761 Main Avenue, Norwalk, CT 06859-0256.

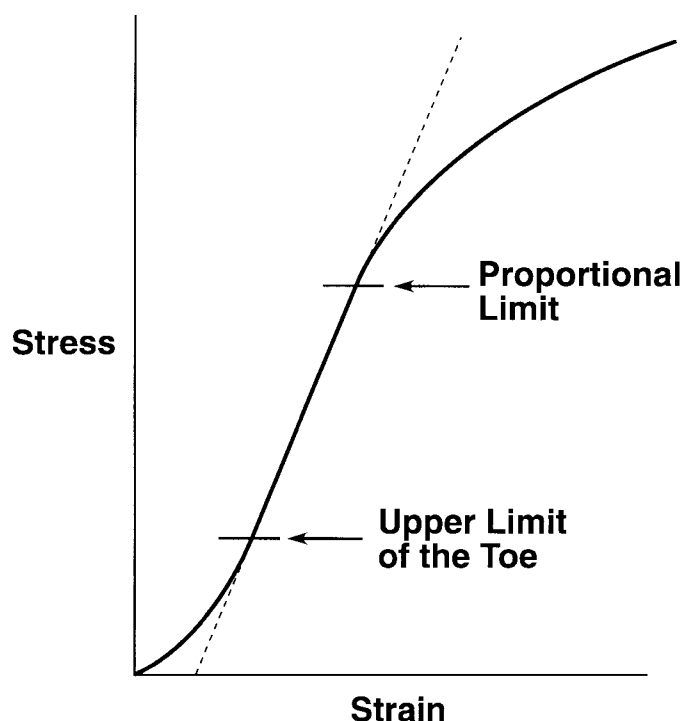

FIG. 1 Stress-Strain Curve (Linear Region)

- Insulating Materials for Testing³
- D 638 Test Method for Tensile Properties of Plastics³
- D 883 Terminology Relating to Plastics³
- D 1999 Guide for the Selection of Specimens and Test Parameters for International Trade³
- D 4092 Terminology Relating to Dynamic Mechanical Measurements on Plastics⁴
- E 177 Practice for the Use of the Terms Precision and Bias in ASTM Test Methods⁵

3. Terminology

3.1 *Definitions:* Definitions of terms applying to these test methods appear in Terminologies D 883 and D 4092, and

³ *Annual Book of ASTM Standards*, Vol 08.01.

⁴ *Annual Book of ASTM Standards*, Vol 08.02.

⁵ *Annual Book of ASTM Standards*, Vol 14.02.

Annex A1 and Annex A2 of Test Method D 638.

4. Summary of Test Method

4.1 A specimen of rectangular cross section is tested in flexure as a beam. The bar rests on two supports and is loaded by means of a loading nose midway between the supports. The test specimen of known geometry is placed under mechanical linear displacement at isothermal conditions by using a controlled rate of loading. The modulus of elasticity is measured using three-point bending.

5. Significance and Use

5.1 This test method provides a simple means of characterizing the mechanical behavior of plastics materials using very small amounts of material. The data obtained may be used for quality control, research and development, and establishment of optimum processing conditions.

5.2 Mechanical testing provides a sensitive test method for determining mechanical characteristics by measuring the modulus of elasticity.

NOTE 2—Materials that are suspected to be too anisotropic may not be suitable for this test method.

5.3 This test method can be used to assess:

- 5.3.1 The effects of processing treatment,
- 5.3.2 Relative resin behavioral properties, including cure,
- 5.3.3 The effects of substrate types and orientation (fabrication) on modulus, and
- 5.3.4 The effects of formulation additives that might affect processability or performance.

6. Interferences

6.1 Since small test specimen geometries are used, it is essential that the specimens be representative of the polymeric material being tested.

7. Apparatus

7.1 The function of the apparatus is to hold a rectangular test specimen of a polymeric material system so that the material acts as the elastic and dissipative element in a mechanically driven linear displacement system. Displacements (deflections) are generated using a controlled loading rate applied to a specimen in three-point bending configuration.

7.2 The apparatus shall consist of the following:

7.2.1 *Loading Nose and Supports*—The loading nose and supports shall have cylindrical surfaces having a sufficient radius to avoid excessive indentation or failure due to stress concentration directly under the loading nose (see Fig. 2).

7.2.2 *Detectors*—A device or devices for determining dependent and independent experimental parameters, such as force (stress) or deflection (strain), and temperature. Temperature should be measurable with a precision of $\pm 1^\circ\text{C}$, deflection to $\pm 1\%$ full scale, and force to $\pm 1\%$ full scale.

7.3 *Optional Accessories:*

7.3.1 *Temperature Controller and Oven*—A device for controlling the temperature, either by heating (in steps or ramps), cooling (in steps or ramps), maintaining a constant specimen environment or a combination of both. A temperature controller should be sufficiently stable to permit measurement of environmental-chamber temperature to within 1°C .

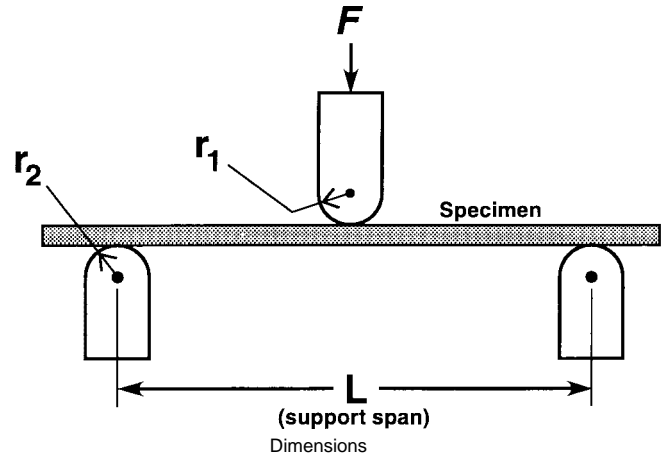

Description	Symbol	Dimension, mm	Tolerance, \pm mm
Support span	L	20.0	0.1
Loading nose radius	r^1	3.0	0.5
Support radius	r^2	1.0	0.1

FIG. 2 Loading Members

7.3.2 *Nitrogen*—Or other inert gas supply, for purging purposes.

8. Test Specimens

8.1 The specimens may be cut from sheets, plates, or molded shapes, or may be molded to the desired finished dimensions. Specimens shall be long enough to allow overhanging on each end of at least 10 % of the support span. Overhang shall be sufficient to prevent the specimen from slipping through the supports. A typical rectangular test beam is tested flatwise on a support span (see Fig. 3 and Fig. 4).

8.2 At least five specimens shall be tested for each sample.

9. Calibration

9.1 Calibrate the instrument using procedures recommended by the manufacturer.

10. Conditioning

10.1 *Conditioning*—Condition the test specimens at $23 \pm 2^\circ\text{C}$ ($73.4 \pm 3.6^\circ\text{F}$) and $50 \pm 5\%$ relative humidity for not less

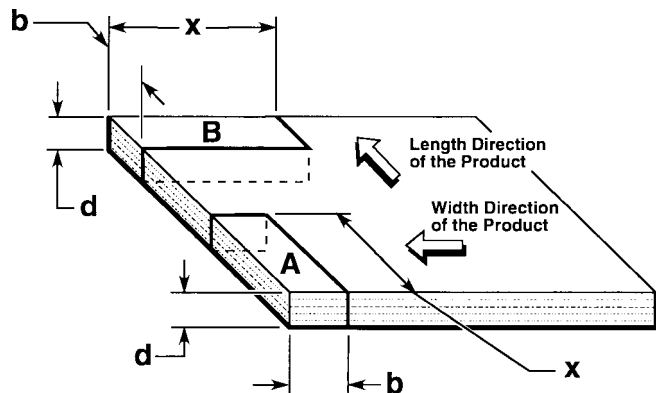
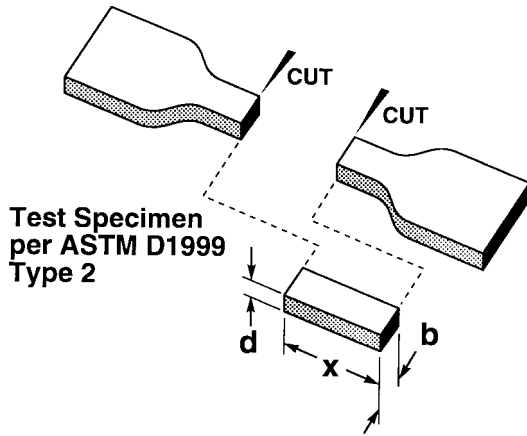

FIG. 3 Specimen Dimensions (Test Specimen Taken from a Sheet)



Description	Symbol	Dimension, mm	Tolerance, ±, mm
Specimen depth	d	2.0	0.1
Specimen length	x	25.0	1.0
Specimen width	b	6.0	+0.4 - 0.1

FIG. 4 Specimen Dimensions

than 40 h prior to testing in accordance with Procedure A of Practice D 618 for those tests where conditioning is required. In cases of disagreement, the tolerances shall be $\pm 1^\circ\text{C}$ ($\pm 1.8^\circ\text{F}$) and $\pm 2\%$ relative humidity.

11. Procedure

11.1 Begin with an untested specimen for each series of measurements. Measure the width and depth of the specimen to the nearest 0.01 mm at the center of the support span.

11.2 Center the specimen on the supports, with the long axis of the specimen perpendicular to the loading nose and supports.

11.3 Pre-load the test specimen with 0.1 N (100 mN) $\pm 1\%$ full scale.

11.4 Apply a linearly increasing force at a rate of 0.5 N/min (500 mN/min) $\pm 1\%$ up to 5.1 N (5100 mN) and record the displacement as a function of time. Terminate the test if the maximum strain has reached 30 mm/m (0.03 mm/mm), (3%), or the proportional limit, the yield force, the rupture force, or the maximum force of the analyzer has been reached, whichever occurs first. This test method is not applicable for strains higher than 3%.

NOTE 3—If the specimen fails or ruptures, then use another specimen and repeat 11.4 using forces that do not exceed the linear region as defined by the failed or ruptured specimen.

11.5 The analysis shall be conducted two times in succession for each specimen. The first analysis can be neglected as it may typically contain specimen-to-measuring system stress relief. This will result in one valid result for each specimen.

12. Calculation

12.1 The arithmetic mean and the standard deviation calculation are used to report the average modulus of elasticity in bending and the standard deviation for each sample consisting of at least five specimens.

12.2 *Modulus of Elasticity*—The modulus of elasticity is the ratio of stress to corresponding strain within the elastic limit,

on the stress-strain curve (see Fig. 1). It shall be expressed in pascal (pounds per square inch). It is calculated in accordance with (Eq 3), by letting M equal the slope of stress-strain curve.

$$\text{Stress} = \sigma = \frac{3FL}{2bd^2} \quad (1)$$

$$\text{Strain} = \epsilon = \frac{6Dd}{L^2} \quad (2)$$

Controlled Rate of Loading Equation

$$E_B = M = \frac{\sigma}{\epsilon} = \frac{3FL}{6Dd} \frac{2bd^2}{L^2} \quad (3)$$

where:

E_B = modulus of elasticity in bending, Pa, (psi),

L = support span, m, (in.),

b = width of beam tested, m, (in.),

d = depth of beam tested, m, (in.),

D = deflection of the beam, m, (in.), and

F = force, N.

NOTE 4—Shear deflections can seriously reduce the apparent modulus of highly anisotropic composites when they are tested at low span-to-depth ratios. Since the modulus in three-point bending of highly anisotropic laminates is a critical function of ply-stacking sequence, it will not correlate necessarily with tensile modulus, which is not stackingsequence dependent.

13. Report

13.1 Report the following information:

13.1.1 Complete identification of the material tested, including type, source, manufacturer's code, number, form, principal dimensions, and previous history,

13.1.2 Direction of cutting and loading specimen, including preload force,

13.1.3 Conditioning procedure,

13.1.4 Description of the instrument used for the test,

13.1.5 Description of the calibration procedure,

13.1.6 Identification of the sample atmosphere by gas composition, purity, and rate used,

13.1.7 Depth and width of specimen,

13.1.8 Support span length,

13.1.9 Support span-to-depth ratio,

13.1.10 Radius of supports and loading nose,

13.1.11 Number of specimens tested,

13.1.12 Table of data and results consisting of modulus for each specimen, mean modulus for each sample, and standard deviation for each sample,

13.1.13 The limits of the region used to calculate the modulus, and

13.1.14 Description of any deviation from this test method.

14. Precision and Bias

14.1 Based on limited information from one laboratory, the repeatability coefficient of variation (CV %_r) is $\pm 5\%$ for a material with a mean modulus of 1.32×10^{10} (see Practice E 177).

15. Keywords

15.1 elasticity; modulus; plastics; rigid; plastics; semi-rigid;
three-point bending

ASTM International takes no position respecting the validity of any patent rights asserted in connection with any item mentioned in this standard. Users of this standard are expressly advised that determination of the validity of any such patent rights, and the risk of infringement of such rights, are entirely their own responsibility.

This standard is subject to revision at any time by the responsible technical committee and must be reviewed every five years and if not revised, either reapproved or withdrawn. Your comments are invited either for revision of this standard or for additional standards and should be addressed to ASTM International Headquarters. Your comments will receive careful consideration at a meeting of the responsible technical committee, which you may attend. If you feel that your comments have not received a fair hearing you should make your views known to the ASTM Committee on Standards, at the address shown below.

This standard is copyrighted by ASTM International, 100 Barr Harbor Drive, PO Box C700, West Conshohocken, PA 19428-2959, United States. Individual reprints (single or multiple copies) of this standard may be obtained by contacting ASTM at the above address or at 610-832-9585 (phone), 610-832-9555 (fax), or service@astm.org (e-mail); or through the ASTM website (www.astm.org).