

This document is not an ASTM standard and is intended only to provide the user of an ASTM standard an indication of what changes have been made to the previous version. Because it may not be technically possible to adequately depict all changes accurately, ASTM recommends that users consult prior editions as appropriate. In all cases only the current version of the standard as published by ASTM is to be considered the official document.



Designation: D 2136 – 94 (Reapproved 1998)

Designation: D 2136 – 02

Standard Test Method for Coated Fabrics—Low-Temperature Bend Test¹

This standard is issued under the fixed designation D 2136; the number immediately following the designation indicates the year of original adoption or, in the case of revision, the year of last revision. A number in parentheses indicates the year of last reapproval. A superscript epsilon (ϵ) indicates an editorial change since the last revision or reapproval.

This standard has been approved for use by agencies of the Department of Defense.

¹This test method is under the jurisdiction of ASTM Committee D-11 on Rubber and is the direct responsibility of Subcommittee D11.14 on Time and Temperature-Dependent Physical Properties.

Current edition ~~Sept. 15, 1994~~, approved Dec. 10, 2002. Published ~~November 1994~~, January 2003. Originally published as ~~D 2136 – 62~~, approved in 1962. Last previous edition ~~D 2136 – 84 (1989)~~ ^{ϵ} , approved in 1998 as D 2136 – 94 (1998).

1. Scope

1.1 Fabrics coated with rubber or rubber-like materials display increased stiffening when exposed to decreasing ambient temperatures. This test method describes a simple pass/fail procedure whereby material flexibility at a specified low temperature can be determined. Failure is indicative of unacceptability of the coated fabric for use at that temperature.

1.2 The values stated in SI units are to be regarded as the standard.

1.3 *This standard does not purport to address all of the safety concerns, if any, associated with its use. It is the responsibility of the user of this standard to establish appropriate safety and health practices and determine the applicability of regulatory limitations prior to use.* For specific precautionary statement see 8.1.

2. Referenced Documents

2.1 *ASTM Standards:*

D 751 Test Methods for Coated Fabrics²

3. Summary of Test Method

3.1 Specimens cut from the coated fabric are conditioned at a selected low temperature for a specified duration. While remaining exposed at that temperature, they are then individually placed in a bending apparatus and bent through a specified angle. Failure of the coated fabric is indicated by fracture of the specimen or the appearance of surface cracks in the coating.

4. Significance and Use

4.1 This test method evaluates the ability of coated fabrics to withstand a prescribed bend at an established low temperature. Fabrics coated with polymeric materials are used in many applications requiring low temperature flexing. Data obtained using this test method may be used to predict in-use behavior only in applications in which the conditions of deformation are similar to those specified in this test method. This test method has been found useful for specification purposes but does not necessarily indicate the lowest temperature at which the material may be used.

5. Apparatus

5.1 *Low-Temperature Chamber*—The chamber in which the test specimens are exposed to low temperature shall be sufficient in size to contain the bending fixture used for testing the specimens and to permit the operation of the fixture to bend the specimens without removal from the chamber. The chamber shall also have sufficient work space to permit the conditioning of test specimens in accordance with Section 8 of this test method. It shall be capable of maintaining a uniform atmosphere of cold dry air or any suitable gas at specified temperatures within a tolerance of $\pm 1^\circ\text{C}$ ($\pm 1.8^\circ\text{F}$).

5.2 *Bending Fixture*³—The basic requirements for the device used for bending the test specimens are shown in Fig. 1 and Fig. 2. Dimensions and mass shall conform to Fig. 2.

5.3 *Glass Plates*—A sufficient number of glass plates approximately 125 by 175 mm (5 by 7 in.) shall be used when conditioning all test specimens. All test specimens shall be placed between glass plates during the exposure period to eliminate any curling or bending. The thickness of the glass plates shall be of such size as to permit ease of handling.

² *Annual Book of ASTM Standards*, Vol 09.02.

³ Detail drawings of this apparatus are available at a nominal cost from the American Society for Testing and Materials, 100 Barr Harbor Drive, Conshohocken, PA 19428. Request ADJD2136.

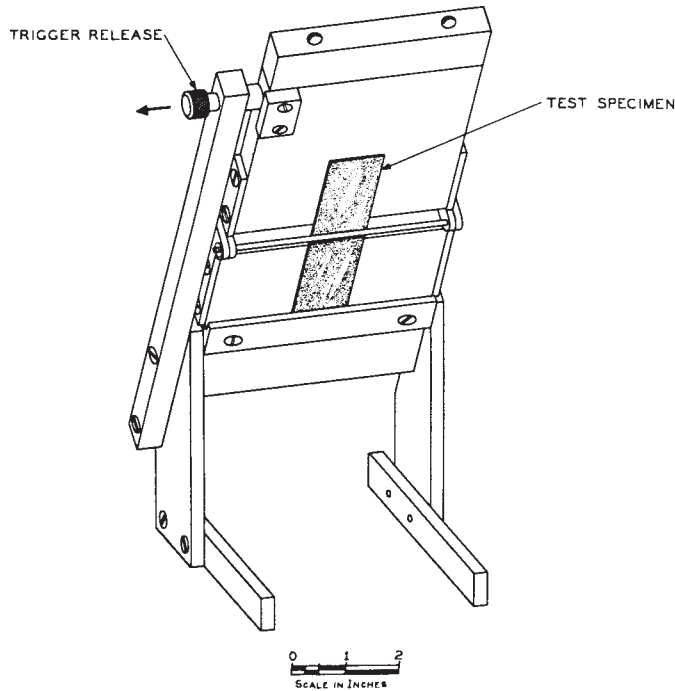

FIG. 1 Bending Jig for Coated Fabrics

5.4 *Gloves*—A pair of gloves shall be required for handling test specimens within the low-temperature chamber.

5.5 *Lubrication*— A suitable low-temperature grease, if needed, should be applied to the trigger release and hinge pin of the bending apparatus to prevent stiffening during the conditioning period.

6. Sampling

6.1 Samples for test specimen preparation shall be taken from roll ends at a frequency agreed upon between the purchaser and the supplier.

7. Test Specimens

7.1 The test specimens shall be 25 ± 1 mm (1 ± 0.04 in.) wide and 100 ± 2 mm (4 ± 0.08 in.) long. They shall be cut with the longer dimension parallel to the lengthwise direction of the coated fabric, unless otherwise specified.

7.2 At least three specimens shall be cut from each sample being tested.

8. Conditioning

8.1 Test specimens shall be conditioned prior to the test in accordance with the standard condition described in Test Methods D 751.

8.2 Place the test specimens between glass plates with sufficient space between each specimen to permit the passage of cold air during the conditioning period. Place the glass plates with the specimens held in position, the bending apparatus and the gloves in the low-temperature chamber. Unless otherwise specified, expose them for 4 h to cold, dry air or any suitable gas at the specified temperature.

9. Procedure

9.1 At the termination of the exposure period, and while still in the test chamber, remove the specimens from between the glass plates one at a time (~~Caution, see Note~~) **Warning**—Gloves must be worn at all times when handling specimens prior to making the bend test.) and place into the bending apparatus with the flexing plate held into the open position by the trigger pin. Face the side to be evaluated away from the mandrel unless otherwise specified. **NOTE 1—Caution: Gloves must be worn at all times when handling specimens prior to making the bend test.**

9.2 As soon as the specimen is in position in the bending apparatus, release the trigger and permit the flexing plate to make a free fall.

9.3 After all specimens have been tested, remove them and examine for fractures or coating cracks under a $5\times$ magnification. During the examination, fold all specimens 180° in the same direction as the bend during the test.

9.4 When three specimens are tested and none fracture or show any cracks in the coating after being tested, the material shall be considered to have passed the bending test. If the three specimens fracture or show cracks, the material shall be considered to have failed.

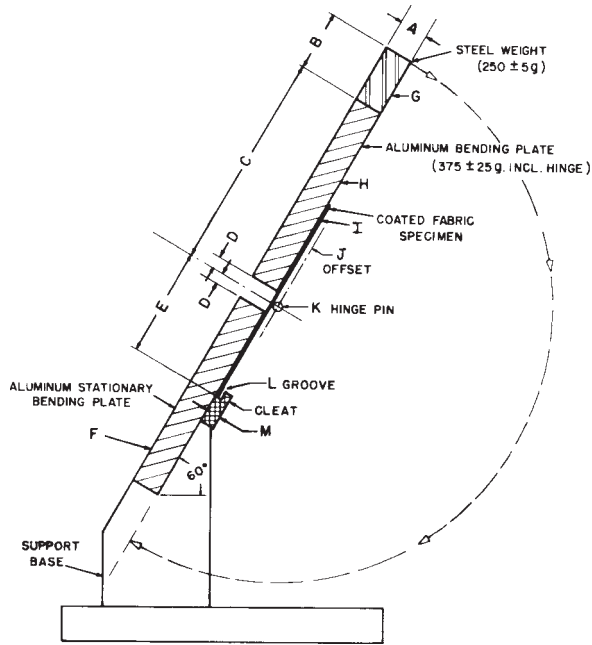

	mm	in.
A	13	0.5
B	25	1
C	100	4
D	5	0.2
E	48	1.9
F	100 × 110 × 13	4 × 4.3 × 0.5
G	100 × 25 × 13	4 × 1 × 0.5
H	100 × 100 × 13	4 × 4 × 0.5
I	100 × 25	4 × 1
J	3	0.12
K	3	0.12
L	3 × 3	0.12 × 0.12
M	6	0.25

FIG. 2 Bending Jig, Schematic Dimensions

9.5 If only one or two specimens show failures, test three additional specimens. If any of these show fractures or coating cracks, the material shall then be considered to have failed.

10. Report

10.1 Report the following information:

10.1.1 Results of the tests expressed as “passed” or “failed,” and the number of specimens tested,

10.1.2 Temperature at which the specimens were tested,

10.1.3 Duration of the exposure period, and

10.1.4 Identification, date of manufacture, and date of test.

11. Precision and Bias

11.1 Since this testing makes use of a pass/fail performance criterion, the application of the usual precision and bias analysis is not possible.

12. Keywords

12.1 bend test; coated fabrics; flexibility; low temperature; low temperature bend test; rubber-coated fabrics; subnormal test temperature

ASTM International takes no position respecting the validity of any patent rights asserted in connection with any item mentioned in this standard. Users of this standard are expressly advised that determination of the validity of any such patent rights, and the risk of infringement of such rights, are entirely their own responsibility.

This standard is subject to revision at any time by the responsible technical committee and must be reviewed every five years and if not revised, either reapproved or withdrawn. Your comments are invited either for revision of this standard or for additional standards and should be addressed to ASTM International Headquarters. Your comments will receive careful consideration at a meeting of the responsible technical committee, which you may attend. If you feel that your comments have not received a fair hearing you should make your views known to the ASTM Committee on Standards, at the address shown below.

This standard is copyrighted by ASTM International, 100 Barr Harbor Drive, PO Box C700, West Conshohocken, PA 19428-2959, United States. Individual reprints (single or multiple copies) of this standard may be obtained by contacting ASTM at the above address or at 610-832-9585 (phone), 610-832-9555 (fax), or service@astm.org (e-mail); or through the ASTM website (www.astm.org).