



Designation: D 6601 – 002

Standard Test Method for Rubber Properties—Measurement of Cure and After-Cure Dynamic Properties Using a Rotorless Shear Rheometer¹

This standard is issued under the fixed designation D 6601; the number immediately following the designation indicates the year of original adoption or, in the case of revision, the year of last revision. A number in parentheses indicates the year of last reapproval. A superscript epsilon (ϵ) indicates an editorial change since the last revision or reapproval.

1. Scope

1.1 This test method covers the use of a rotorless oscillating shear rheometer for measuring after cure dynamic properties at predetermined temperature(s) below the cure temperature.

1.2 Specified cure conditions that approximate a “static cure” also are covered to minimize effects on cured rubber compound dynamic properties. This test method is not intended to replace Test Method D 5289.

1.3 *This standard does not purport to address all of the safety concerns, if any, associated with its use. It is the responsibility of the user of this standard to establish appropriate safety and health practices and determine the applicability of regulatory limitations prior to use.*

1.4 **Warning**—Compounds based on silicone or fluoroelastomers may have high levels of thermal contraction or poor adhesion to the dies when cooled after the cure portion of this test method, causing slippage during strain sweeps. If this occurs, the results will not be reliable.

2. Referenced Documents

2.1 *ASTM Standards:*

¹ This test method is under the jurisdiction of ASTM Committee D11 on Rubber and is the direct responsibility of Subcommittee D11.14 on Time and Temperature-Dependent Physical Properties.

Current edition approved Nov. Dec. 10, 2000². Published December January 2003. Originally approved in 2000. Last previous edition approved in 2000 as D 6601 – 00.

D 1349 Practice for Rubber—Standard Temperatures for Testing²

D 4483 Practice for Determining Precision for Test Method Standards in the Rubber and Carbon Black Industries²

D 5289 Test Method for Rubber Property—Vulcanization Using Rotorless Cure Meters²

D 5992 Guide for Dynamic Testing of Vulcanized Rubber and Rubber-Like Materials Using Vibratory Methods²

3. Terminology

3.1 *Definitions of Terms Specific to This Standard:*

3.1.1 *complex shear modulus, G^* , n* —the ratio of peak amplitude shear stress to peak amplitude shear strain; mathematically, $G^* = (G'^2 + G''^2)^{1/2}$.

3.1.2 *complex torque, S^* , n* —the peak amplitude torque response measured by a reaction torque transducer for a sinusoidally applied strain; mathematically, S^* is computed by $S^* = (S'^2 + S''^2)^{1/2}$.

3.1.3 *dynamic cure, n* —any cure condition which oscillates or moves the die.

3.1.4 *elastic torque, S' , n* —the peak amplitude torque component, which is in phase with a sinusoidally applied strain.

3.1.5 *loss angle, δ , n* —the phase angle by which the complex torque (S^*) leads a sinusoidally applied strain.

3.1.6 *loss factor, $\tan \delta$, n* —the ratio of loss modulus to storage modulus, or the ratio of viscous torque to elastic torque; mathematically, $\tan \delta = G''/G' = S''/S'$.

3.1.7 *loss shear modulus, G'' , n* —the component of applied stress that is 90° out-of-phase with the shear strain, divided by the strain.

3.1.8 *static cure, n* —the cure conditions of 0.0° arc strain and 0.0 Hz in frequency, that is, no movement of the dies during the cure test.

3.1.9 *storage shear modulus, G' , n* —the component of applied stress that is in phase with the shear strain, divided by the strain.

3.1.10 *viscous torque, S'' , n* —the peak amplitude torque component, which is 90° out of phase with a sinusoidally applied strain.

4. Summary of Test Method

4.1 A rubber test specimen is contained in a die cavity that is closed and maintained at an elevated cure temperature. The cavity is formed by two dies, one of which is oscillated through a rotary amplitude. This action produces a sinusoidal torsional strain in the test specimen resulting in a sinusoidal torque, which measures the viscoelastic changes of the test specimen as it cures. The test specimen must be a unvulcanized rubber compound containing curatives. A controlled limited strain is applied during cure to prevent effecting the aftercure properties.

4.2 After a predetermined cure time, the temperature is reduced and dynamic property measurements can be based on a strain sweep in which the strain amplitude is programmed to change in steps under constant frequency and temperature, a frequency sweep in which the frequency is programmed to change in steps under constant strain amplitude and temperature, or, a temperature sweep in which the temperature is programmed to decrease under constant strain amplitude and frequency conditions.

4.3 For an after-cure strain sweep, the instrument is typically programmed to increase the strain with each subsequent step change. This is done to minimize the influence of prior test conditions on subsequent test steps. Typically two repeat strain sweeps may be programmed consecutively to quantify the Payne Effect³, which is the reduction in dynamic storage modulus from strain softening of the rubber vulcanizate.

5. Significance and Use

5.1 This test method is used to determine the vulcanization characteristics of (vulcanizable) rubber compounds under selected test conditions of strain and frequency which do not significantly affect the cured dynamic properties. In the same test, this test method also will measure the dynamic properties of the vulcanizate at temperatures significantly below the cure temperature. These lower temperature measurements are necessary in order to more effectively relate to rubber product service conditions.

5.2 This test method may be used for quality control in rubber manufacturing processes and for research and development testing of rubber compounds containing curatives. This test method also may be used for evaluating cure and dynamic property differences resulting from the use of different compounding ingredients.

5.3 For additional information regarding the significance of dynamic testing of vulcanized rubber, the reader may wish to reference Guide D 5992.

6. Apparatus

6.1 *Torsion Strain Rotorless Oscillating Rheometer with a Sealed Cavity*—This type of rheometer measures the elastic torque S' and viscous torque S'' produced by oscillating angular strain of set amplitude and frequency in a completely closed and sealed test cavity.

6.2 *Sealed Die Cavity*—The sealed die cavity is formed by two conical surface dies. In the measuring position, the two dies are fixed a specified distance apart so that the cavity is closed and sealed (see Fig. 1).

² Annual Book of ASTM Standards, Vol 09.01.

³ A.R. Payne, *J. Polymer Sci.*, 6, 57 (1962).

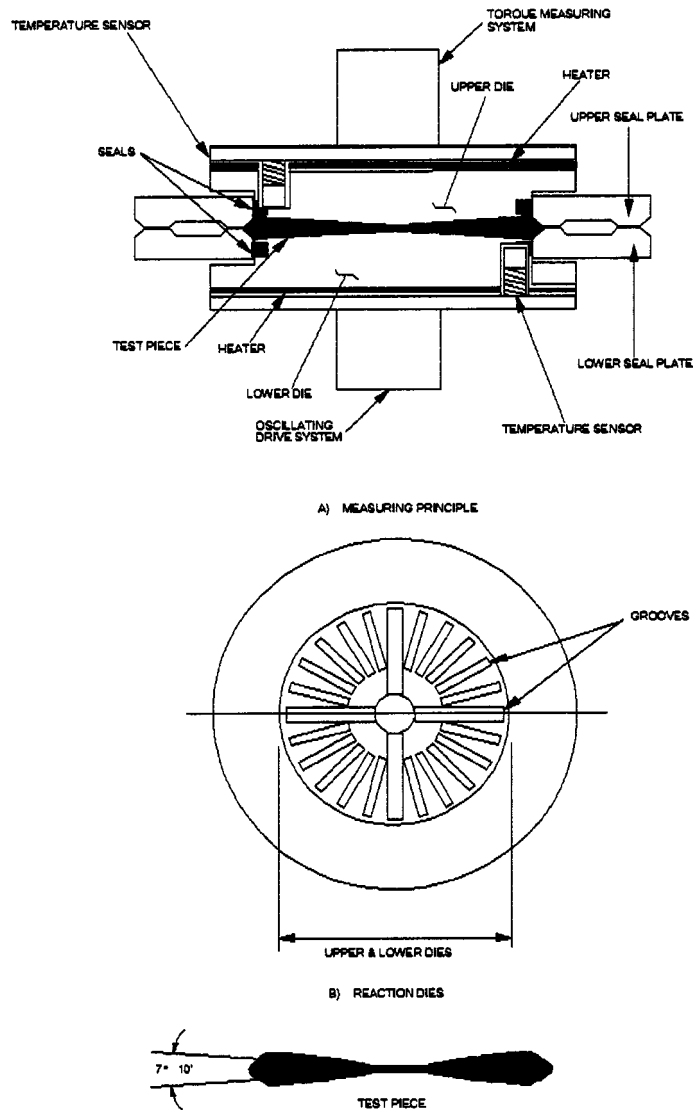

FIG. 1 Typical Sealed Torsion Shear Rotorless Curemeter

6.3 *Die Gap*—For the sealed cavity, no gap should exist at the edges of the dies. At the center of the dies, the die gap shall be set at 0.45 ± 0.05 mm.

6.4 *Die Closing Mechanism*—For the sealed cavity, a pneumatic cylinder or other device shall close the dies and hold them closed during the test with a force not less than 11 kN (2500 lbf).

6.5 *Die Oscillating System*—The die oscillating system consists of a direct drive motor, which imparts a torsional oscillating movement to the lower die in the cavity plane.

6.5.1 The oscillation amplitude can be varied, but a selection of 0.2° arc ($\pm 2.8\%$ shear strain) is preferred for the cure test while strains from ± 1 to $\pm 100\%$ are preferred for the after-cure strain sweeps. The oscillation frequency can be varied between 0.03 Hz and 30 Hz.

6.6 *Torque Measuring System*—The torque measuring system shall measure the resultant shear torque.

6.6.1 The torque measuring device shall be rigidly coupled to the upper die, any deformation between the die and device shall be negligibly small, and the device shall generate a signal, which is proportional to the torque. The total error resulting from zero point error, sensitivity error, linearity, and repeatability errors shall not exceed 1% of the selected measuring range.

6.6.2 The torque recording device shall be used to record the signal from the torque measuring device and shall have a response time for full scale deflection of the torque scale of 1 s or less. The torque shall be recorded with an accuracy of $\pm 0.5\%$ of the range. Torque recording devices may include analog chart recorders, printers, plotters, or computers.

6.6.3 A reference torque device is required to calibrate the torque measurement system. A torque standard may be used to calibrate the torque measuring system at the selected angular displacement by clamping a steel torsion rod to the oscillating and the torque measuring dies of the torsion shear rheometer (see Fig. 2). The reference values for angular displacement and corresponding torque shall be established by the manufacturer for each torque standard.

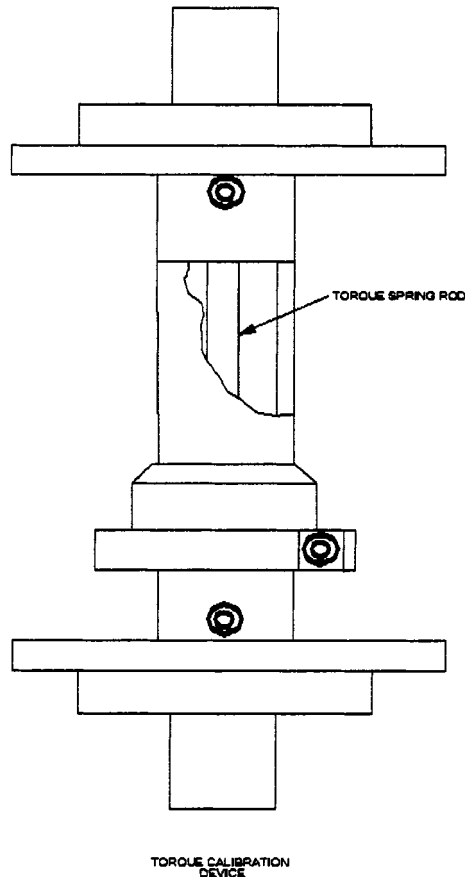

FIG. 2 Typical Torque Standard Calibration Device for Torsion Shear Curemeters

6.7 *Reference Test Temperature*—The standard reference test temperature for cure shall be either 140°C, 160°C, or 180°C while dynamic property measurements after-cure (dynamic property measurements made after completion of the cure test) should be made at either 100°C or 60°C. Tests may be carried out at other temperatures, if required. Other temperatures should be selected in accordance with Practice D 1349 when practical.

6.8 *Temperature Control System*—This system shall permit the reference temperature to be varied between 40°C and 220°C with an accuracy of $\pm 0.3^\circ\text{C}$ or better.

6.8.1 The dies shall heat to the set point temperature in 1.0 min or less from closure of the test cavity. Once the initial heating up time has been completed, die temperature shall not vary by more than $\pm 0.3^\circ\text{C}$ for the remainder of a cure test at a set temperature. When the set temperature is changed in a programmed temperature sweep or strain sweep, dynamic property measurements should not be recorded until the die temperatures are within $\pm 0.3^\circ\text{C}$ of the new set temperature for at least 30 s.

6.8.2 Temperature distribution within the test piece shall be as uniform as possible. Within the deformation zone, a tolerance of $\pm 1^\circ\text{C}$ of the average test piece temperature shall not be exceeded.

6.8.3 Die temperature is determined by a temperature sensor used for control. The difference between the die temperature and the average test piece temperature shall not be more than 2°C . Temperature measurement accuracy shall be $\pm 0.3^\circ\text{C}$ for the die temperature sensor.

6.8.4 The upper and lower dies shall each be jacketed with forced air cooling devices in order to rapidly decrease the temperature of the upper and lower dies after the cure test is completed.

7. Test Specimen

7.1 A test specimen taken from a sample shall be between 5 and 6 cm³ for the sealed cavity oscillating rheometer. The specimen volume should exceed the test cavity volume by a small amount, to be determined by preliminary tests. Typically, specimen volume should be 130 to 150 % of the test cavity volume. Once a target mass for a desired volume has been established, specimen masses should be controlled to within ± 0.5 g for best repeatability. The initial test specimen shape should fit well within the perimeter of the test cavity.

7.2 *Compounded Rubber Specimens*—Test specimens shall be taken from a rubber compound as required by the mixing method or other sampling instructions. Only rubber compounds with curatives may be tested.

7.2.1 The rubber compound shall be in the form of a sheet, at room temperature, and as free of air as possible.

8. Procedure

- 8.1 Select from one of six different cure conditions shown in Table 1.
- 8.2 Select from one of eight different after-cure dynamic testing conditions shown in Table 2.
- 8.3 Program a test configuration which incorporates these conditions and store on the instrument computer operating system.
- 8.4 Load the test configuration to run the test.
- 8.5 Enter specimen identification.
- 8.6 Wait until both dies are at the initial test temperature. Open the test cavity and visually check both upper and lower dies for cleanliness. Clean the dies, if necessary. Place the test specimen on the center of the lower die and close the dies within 20 s.

9. Report

- 9.1 Report the following information.
 - 9.1.1 A full description of the sample, or test specimen(s), or both, including their origin.
 - 9.1.2 Type and model of oscillating rheometer.
 - 9.1.3 The frequency, strain, temperature and time for the cure test (if no strain, indicate “static cure”).
 - 9.1.4 Minimum torque (M_L) as dNm, maximum torque (M_H) as dNm, time to scorch as indicated by time to one unit rise (in dNm units) from minimum torque (t_{SJ}) in minutes and decimal fraction of a minute, and time to 10 %, 50 %, and 90 % state of cure in minutes and decimal fraction of a minute.

NOTE 1—For static cure, no cure properties are reported since no measurements are possible.

- 9.1.5 The temperature, frequency and different strains applied in an after-cure strain sweep.
- 9.1.6 The storage shear modulus G' in kPa and the percent strain for each step in the programmed strain sweep.
- 9.1.7 The loss shear modulus G'' in kPa and the percent strain for each step in the programmed strain sweep.
- 9.1.8 The tangent delta ($\tan \delta$) and the percent strain for each step in the programmed strain sweep.
- 9.1.9 If two consecutive strain sweeps are programmed, the results from both of these strain sweeps should be recorded (reference the Payne Effect discussed in 4.3).

10. Precision and Bias

- 10.1 A precision and bias estimate has not been completed for this test method at this time. This will be completed in accordance with Practice D 4483.

11. Keywords

- 11.1 dynamic properties; loss modulus; rotorless oscillating shear rheometer; storage modulus

TABLE 1 Test Conditions for Cure Test^A

NOTE 1—Cure properties should be measured in accordance with Test Method D 5289.

Cure Condition No.	Temperature, °C	Frequency, Hz	Strain, ± ° Arc.
1	140	1.67	0.2
2	160	1.67	0.2
3	180	1.67	0.2
4	140	0	0
5	160	0	0
6	180	0	0

^A Please note that cure conditions of 0.2° arc strain and 1.67 Hz frequency may influence post cure properties

TABLE 2 Test Conditions for After-Cure Strain Sweeps

Dynamic Property Condition No.	First Strain Sweep			Second Strain Sweep		
	Temperature °C	Frequency, Hz	Strain ^A , ± %	Temperature °C	Frequency, Hz	Strain ^A , ± %
1	100	1	1,2,5,10,20	100	1	1,2,5,10,20
2	100	10	1,2,5,10,20	100	10	1,2,5,10,20
3	60	1	1,2,5,10,20	60	1	1,2,5,10,20
4	60	10	1,2,5,10,20	60	10	1,2,5,10,20

^A If a specially soft compound with a Shore A Durometer below 40 is tested, additional strain conditions of 50 and 100 % may be added to the strain sweeps.

ASTM International takes no position respecting the validity of any patent rights asserted in connection with any item mentioned in this standard. Users of this standard are expressly advised that determination of the validity of any such patent rights, and the risk of infringement of such rights, are entirely their own responsibility.

This standard is subject to revision at any time by the responsible technical committee and must be reviewed every five years and if not revised, either reapproved or withdrawn. Your comments are invited either for revision of this standard or for additional standards and should be addressed to ASTM International Headquarters. Your comments will receive careful consideration at a meeting of the responsible technical committee, which you may attend. If you feel that your comments have not received a fair hearing you should make your views known to the ASTM Committee on Standards, at the address shown below.

This standard is copyrighted by ASTM International, 100 Barr Harbor Drive, PO Box C700, West Conshohocken, PA 19428-2959, United States. Individual reprints (single or multiple copies) of this standard may be obtained by contacting ASTM at the above address or at 610-832-9585 (phone), 610-832-9555 (fax), or service@astm.org (e-mail); or through the ASTM website (www.astm.org).