



Designation: **D 1531 – 9501**

An American National Standard

Standard Test Methods for Relative Permittivity (Dielectric Constant) and Dissipation Factor by Fluid Displacement Procedures¹

This standard is issued under the fixed designation D 1531; the number immediately following the designation indicates the year of original adoption or, in the case of revision, the year of last revision. A number in parentheses indicates the year of last reapproval. A superscript epsilon (ϵ) indicates an editorial change since the last revision or reapproval.

This standard has been approved for use by agencies of the Department of Defense.

1. Scope

1.1 These test methods provide techniques for the determination of the relative (Note 1) permittivity and the dissipation factor of solid insulating materials by fluid (Note 2) displacement.

NOTE 1—In common usage, the word “relative” is frequently dropped.

NOTE 2—The word “fluid” is a commonly used synonym for “liquid” and yet a gas is also a fluid. In these test methods the words fluid and liquid appear as synonyms, but the word fluid is also used to show that liquid is not all that is meant.

1.2 Test Method A is especially suited to the precise measurements on polyethylene sheeting at 23°C and at frequencies between

¹ These test methods are under the jurisdiction of ASTM Committee ~~D-9~~ D09 on Electrical and Electronic Insulating Materials and are the direct responsibility of Subcommittee D09.12 on Electrical Tests.

Current edition approved ~~July 15, 1995~~, Mar. 10, 2001. Published ~~September 1995~~, May 2001. Originally published as D 1531 – 58 T. Last previous edition ~~D 1531 – 90¹~~, D 1531 – 95.

1 kHz and 1 MHz. It may also be used at other frequencies² and temperatures to make measurements on other materials in sheet form.

1.3 Test Method B is limited to the frequency range of available guarded bridges. It is especially suited to measurements on very thin films since it does not require determination of the thickness of the specimen. The test method provides an estimate of the thickness of thin films which is more accurate and precise than thickness measurements obtained by other means.

1.4 Test Method B is also useful for measurements of polymer sheeting up to 2 mm thickness.

1.5 These test methods permit calculation of the dissipation factor of the specimens tested.

1.6 *This standard does not purport to address all of the safety concerns, if any, associated with its use. It is the responsibility of the user of this standard to establish appropriate safety and health practices and determine the applicability of regulatory limitations prior to use.* For a specific precautionary statement, see Note 3.

1.7 The values stated in SI units are to be regarded as the standard.

2. Referenced Documents

2.1 ASTM Standards:

D 150 Test Methods for AC Loss Characteristics and Permittivity (Dielectric Constant) of Solid Electrical Insulating Materials³

D 374 Test Methods for Thickness of Solid Electrical Insulation³

D 618054 Practice for Conditioning Plastics and Electrical Insulating Materials for Testing⁴

D 831 Test Method for Gas Content of Cable and Capacitor Oils⁵

D 924 Test Method for Dissipation Factor (or Power Factor) and Relative Permittivity (Dielectric Constant) of Electrical Insulating Liquids⁵

D 1711 Terminology Relating to Electrical Insulation³

E 1 Specification for ASTM Thermometers⁶

3. Terminology

3.1 Definitions—Definitions are in accordance with Terminology D 1711.

3.2 *Description of a Term Specific to This Standard:*

3.2.1 *compatibility, n*—A fluid is considered compatible with a test specimen if, during the time required to complete a test of the specimen in the fluid at the specified temperature and frequency, the calculated permittivity of the specimen does not change by more than 0.1 %, and the dissipation factor change is less than 0.0001.

4. Summary of Test Methods

4.1 *Test Method A— The single fluid technique:*

4.1.1 Measurements are made with a fixed-plate, two-terminal self-shielded test cell assembly. By two measurements, one with the cell filled with the fluid (which in this case is a liquid) only and the second one with the solid specimen immersed in the liquid, a change in capacitance is determined. This capacitance difference is used with the approximate thickness of the specimen, the plate spacing, and the precisely known permittivity of the liquid to calculate the permittivity of the specimen. The dissipation factor of the test specimen is calculated from measurements of the cell with the liquid alone and with the specimen immersed in it. Precision and accuracy are made high by limiting the proportion of fluid to solid, limiting the difference in permittivity between the fluid and the solid, and designing the cell so that both the stray capacitance and the sensitivity limit of the measuring instrument are very small relative to that part of the capacitance due to the specimen. Also, due to its bulk, the measuring system is insensitive to mechanical and thermal disturbances. Since it is not necessary to know the thickness of the specimen accurately and it is not necessary to apply electrodes, there is an overall saving in testing time.

4.2 *Test Method B*—This is a two fluid technique that uses a rigidly constructed, fully shielded, temperature controlled cell.

4.2.1 The fluids are:

4.2.1.1 Two liquids, or

4.2.1.2 One liquid and a gas such as air or nitrogen.

4.2.2 Observations of capacitance and dissipation factor from the four following conditions are used to compute relative permittivity, dissipation factor, and the thickness of the specimen:

4.2.2.1 Without a solid specimen but with a single fluid in the cell,

4.2.2.2 Without a solid specimen but with a fluid different from that in 4.2.1.1,

4.2.2.3 With a solid specimen and with the single fluid of 4.2.1.1, and

4.2.2.4 With a solid specimen and with the different fluid of 4.2.1.2.

² Coutlee, K. G., "Liquid Displacement Test Cell for Dielectric Constant and Dissipation Factor up to 100 Mc," 1959 Annual Report, Conference on Electrical Insulation, National Research Council, Publication 756, Washington, DC.

³ *Annual Book of ASTM Standards*, Vol. 10.01.

⁴ *Annual Book of ASTM Standards*, Vol. ~~08.01~~ 10.02.

⁵ *Annual Book of ASTM Standards*, Vol. 10.03.

⁶ *Annual Book of ASTM Standards*, Vol. 14.03.

TEST METHOD A—LIQUID DISPLACEMENT METHOD USING A SINGLE FLUID
5. Significance and Use
5.1 Permittivity:

5.1.1 *Polyethylene and Materials of Permittivity within 0.1 of that of Polyethylene*—Since the permittivity of benzene or 1 cSt silicone fluid is very close to that of polyethylene, these fluids are recommended for highly accurate and precise testing of polyethylene or other materials with permittivity close to that of polyethylene. These properties of the test method make it a suitable tool to determine batch to batch uniformity of a polyethylene compound in order to meet precise requirements of high capacitance-uniformity and capacitance-stability in electronic apparatus. It also serves as a means to detect impurities, as well as changes resulting from prolonged exposure to high humidity, water immersion, weathering, aging, processing treatments, and exposure to radiation.

5.1.2 *Other Materials*—The test method may provide advantages for routine testing of materials with a poorer match in permittivity between these liquids and the specimen than that required above, because of the ease of testing, and the dilution of errors due to inaccurate thickness. Correction factors can be calculated to account for the bias introduced by the permittivity mismatch. Also, other compatible liquids of appropriate and known dielectric properties different from the two mentioned above are available.

5.2 *Dissipation Factor*—Normally, polyethylene has a very low dissipation factor, and a test specimen exhibiting an abnormally high dissipation factor would be suspected of containing impurities or being contaminated. The reproducibility of dissipation factor by this test method is somewhat better than that obtainable with the more conventional methods, but is limited by the sensitivity of commercially available measuring apparatus.

6. Apparatus

6.1 *Measuring Circuits*—Any low-voltage bridge or resonant-circuit method conforming to the requirements of Test Methods D 150 is suitable when the parallel substitution method is employed. A capacitance sensitivity and readability of about 0.01 pF and a dissipation factor sensitivity and readability of at least 0.00001 is needed. One means for obtaining this sensitivity at 100 kHz and above is by using commercially available resonant circuit apparatus and high Q coils (500 minimum).

6.2 *Leads and Connectors*—Low-loss coaxial connectors and leads are recommended for connecting the cell to bridges equipped with guard circuits for frequencies from 1000 Hz to 1 MHz. Terminate the guard as close as possible to the cell.

6.3 A rigid lead construction is necessary for connecting the cell to unguarded circuits including resonant circuits. Such construction stabilizes stray capacitance. Bare #10 AWG (2.5 mm dia) copper is suitable if rigidly mounted and maintained in the same position throughout the tests. At frequencies of 1 MHz and higher, lead resistance and contact resistance become important because they affect dissipation factor measurements of 0.0001 or less. Contact resistance can be minimized by use of bright solid copper clips for connections. Such clips should be small in size to minimize the effect that placement of the clip has on the measured capacitance. Take care to keep the variations in capacitance between leads and surrounding objects to less than 0.01 pF during measurements.

6.4 The measuring cell in which the test specimens are immersed in the liquid is shown in Fig. 1. It is a two-terminal, self-shielded type cell consisting of a rectangular 6.35 mm (¼ in.) thick gold-plated brass center electrode having parallel and flat faces, each 58.06 cm² (9.00 in.²) in area. This electrode is supported by 5 polytetrafluoroethylene post insulators, and is located midway between two gold-plated brass electrodes which form an integral part of the walls of the cell. The standard spacing between the plates is 1.52 ± 0.05 mm (0.060 ± 0.002 in.); however, other spacings may be used to accommodate test specimens of thicknesses other than 1.27 mm (0.050 in.), such as 1.6 and 3.2-mm (⅛ and ⅜-in.) test specimens. The center electrode slides in grooves and can be removed readily to permit easy cleaning. The cell is equipped with an overflow pipe in order to maintain a constant level of the liquid with the test specimens either in or out. The cooling effect resulting from the evaporation of the liquid is small at the specified test temperature due to the large mass of metal and the small area of liquid exposed to the air, so that under normal testing conditions the required stability of capacitance and temperature can be obtained without the use of a cover.

6.5 *Thermometer*—An ASTM Engler Viscosity Thermometer having a range from 18 to 28°C and conforming to the requirements for Thermometer 23°C in Specification E 1 can be used.

7. Standard Liquid Dielectrics

7.1 *Silicone Liquid*—Use a 1.0 cSt (1×10^{-6} m²/s) silicone fluid. The permittivity of the liquid changes with temperature and has to be measured to determine the exact value for each lot of material. Use the three-terminal measuring cells and procedures of Test Method D 924 for this purpose. The values of silicone liquid are quite similar to those of dry ACS grade benzene as shown in Table 1. The dissipation factor of 1.0 cSt silicone liquid is less than 0.000005 from 100 kHz to 1 MHz and therefore can be considered zero over this frequency range. The liquid can be used a number of times or until an increase in dissipation factor is observed.

7.2 *Benzene*—Use certified ACS reagent-grade (thiophene-free) benzene having a permittivity as specified in Table 1 as the referee liquid. As the permittivity of a liquid is a function of temperature, measure the temperature of the cell to an accuracy of ±0.1°C both with the test specimens in and out. The permittivity values shown in Table 1 are for benzene that has been dried over powdered calcium hydride for 3 months. U.S. commercial certified ACS reagent-grade benzene has been found generally

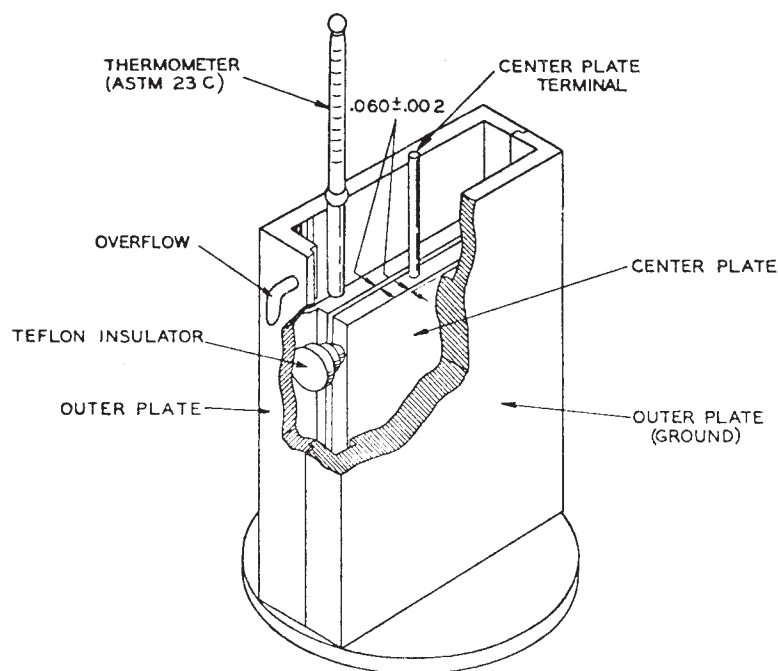

Plate assembly shall be a sliding fit in the cell subassembly; if necessary the polytetrafluoroethylene post insulators may be modified very slightly to accomplish this. The tolerances on the component parts have been apportioned so as to provide a spacing of 1.52 ± 0.05 mm (0.060 ± 0.002 in.).

FIG. 1 Measuring Cell For Test Method A

TABLE 1 Permittivity Values for Dry Benzene

| Temperature, ° C | Permittivity | Temperature, ° C | Permittivity |
|------------------|--------------|------------------|--------------|
| 21.8 | 2.2802 | 23.2 | 2.2775 |
| 22.0 | 2.2798 | 23.4 | 2.2771 |
| 22.2 | 2.2794 | 23.6 | 2.2768 |
| 22.4 | 2.2790 | 23.8 | 2.2764 |
| 22.6 | 2.2787 | 24.0 | 2.2760 |
| 22.8 | 2.2783 | 24.2 | 2.2756 |
| 23.0 | 2.2779 | 24.4 | 2.2752 |

satisfactory. However, in case of a dispute, dry the benzene as above, or measure the permittivity of the benzene, or both. The dissipation factor of the benzene shall not exceed 0.00001 during test. From 100 kHz to 1 MHz, the dissipation factor of ACS reagent-grade benzene is consistently less than 0.000005. The benzene can be used a number of times or until an increase in dissipation factor is observed.

NOTE 3—**Precaution:** Observe proper precautions due to the toxicity and flammability of benzene. Minimize benzene fumes from test specimens by dropping the specimens in a beaker and covering it at once. A portable hood placed near the cell will also remove benzene fumes.

7.3 Other liquids may be used. Those selected should have a permittivity which is approximately the same as that of the specimen, and is known precisely; that is to the fourth decimal place at the test frequency.

7.4 Avoid liquids that dissolve any constituents of the specimen, result in swelling of the specimen, or are absorbed within the body of the specimen.

7.5 Avoid liquids that exhibit peaks in dissipation factor in excess of 0.00005 in the frequency range ± 50 % of the test frequency.

8. Sampling

8.1 Take samples according to the applicable material specification, and observe the following precautions in handling.

8.1.1 Handle specimens with tweezers so that no fingerprints or other contamination is introduced onto the specimen. This precaution is very important for polyethylene, and is expected to be very important for other materials also.

8.1.2 Note the handling precautions of Test Method B which relate to removing surface contamination and maintaining a clean surface between sampling and test, not only to improve precision, but also to keep the apparatus and the liquid(s) clean (see Section 18).

9. Test Specimens

9.1 Mold the sheets of the material to be tested to a thickness of 1.27 ± 0.12 mm (0.050 ± 0.005 in.) (see 9.3) and of sufficient size to cut two pieces 68.3 by 100 mm ($2\frac{11}{16}$ by $3\frac{15}{16}$ in.) from them. These two pieces constitute a test specimen, but in the

following text, each piece is referred to as a test specimen. The number of tests required for each compound is as required by the material specification.

9.2 Materials having thicknesses other than 1.27 mm (0.050 in.) may be tested by changing the thickness of the center electrode so that the test specimens occupy approximately 80 % of the gap. For referee tests, use a 1.27-mm specimen in a 1.52-mm (0.060-in.) gap.

9.3 Measure the thickness of each test specimen to the nearest 0.025 mm (0.001 in.) in accordance with Method A or C of Test Methods D 374. Use the average of five determinations along the diagonals of the specimen, one near the center and one near each end in calculating the permittivity. Measure the specimen under the same atmospheric conditions as described in 10.1.

10. Conditioning

10.1 Unless otherwise specified, condition the test specimens for 40 h in the Standard Laboratory Atmosphere of 50 ± 5 % relative humidity and $23 \pm 2^\circ\text{C}$ as described in Procedure A of Practice ~~D 618~~, D 6054. Store the liquid container and test cell in the Standard Laboratory Atmosphere for a sufficient length of time for the temperature to equilibrate. The temperature of the specimens and the liquid should be exactly the same to obtain the optimum degree of accuracy.

10.2 If the effects of other environmental conditions are to be explored, such as exposure to high humidity, water immersion, weathering, or other treatments, measure the test specimens as soon as practicable after removal from the particular environmental condition, allowing only sufficient time for the test specimens to come to equilibrium with the temperature of the liquid and the test cell.

10.3 If tests are made at a temperature other than 23.0°C , a correction for the temperature coefficient of permittivity of the polymer compound may be necessary.

11. Procedure

11.1 *Air Capacitance and Dissipation Factor of Cell*—It is not necessary to measure the actual air capacitance and dissipation factor of the empty cell in the determination of the permittivity of the polyethylene test specimens. However, such information is of interest from capacitance stability and contamination standpoints. The recommended procedure for preparing a new test cell for use is to rinse the cell several times with warm distilled water followed by a few rinsings with acetone and then benzene. After drying at about 50°C for about 1 h, allow the cell to cool to room temperature. After this treatment the dissipation factor should be less than 0.00001.

11.2 *Capacitance and Dissipation Factor of Cell Containing Liquid Only:*

11.2.1 Fill the cell slowly with liquid, about 50 mL, either directly from the original bottle or from a chemically-clean glass container equipped with a small glass tube, such as a wash-water bottle equipped with a rubber bulb. Fill the cell until a small quantity flows out of the overflow tube into a catch bottle.

11.2.2 Balance or tune the test circuit and record the total capacitance, C_T , in the bridge arm or resonant circuit. Then connect the grounded lead from the measuring circuit to any convenient location on the metal case of the cell. Accurately locate the ungrounded lead so that it is about 25 mm above the center terminal of the cell. This lead should descend from a vertical direction in order to maintain maximum clearance from all surrounding parts, including the thermometer. If coaxial leads and connectors are used, disconnect them at the cell end. Balance or tune the test circuit and record the capacitance, C_0 . Also record readings of the conductance, G_0 , the quality factor, Q_0 , or the dissipation factor, D_0 .

11.2.3 Attach the ungrounded lead by moving it downward to the center terminal, or plug in the coaxial connector, and rebalance or retune the test circuit. Then determine the capacitance, C_l , of the cell containing liquid alone, and the dissipation factor, D_l , of the liquid. Specifically, record readings of measuring circuit capacitance, C_1 , and conductance, G_1 , quality factor, Q_1 , or dissipation factor, D_1 , for use in calculation of C_l and D_l by equations given in 12.2.1. Normally, at frequencies from about 100 kHz to 1 MHz, the value obtained for D_l will be only an apparent value rather than the true value because of lead and contact resistances.

11.3 *Capacitance and Dissipation Factor of Cell Containing Liquid and Specimen*—Without disturbing the position of the ungrounded lead still connected to the center terminal, carefully insert the two test specimens between the plates of the test cell, using clean metal tweezers. Except as provided for in Section 7, discard the liquid that flows out through the overflow tube as the test specimens are inserted. Rebalance or retune the test circuit and determine the capacitance, C_c , and the dissipation factor, D_c , of the cell containing the combination of test specimens and liquid. Specifically, record readings of measuring circuit capacitance, C_2 , and conductance, G_2 , quality factor, Q_2 , or dissipation factor, D_2 , for use in calculation of C_c and D_c by equations given in 12.2.1. If possible, observe directly and record the change of capacitance, ΔC , of the test cell resulting from introduction of the test specimens. Note that ΔC is positive if the cell capacitance was increased, or negative if the cell capacitance was decreased by insertion of the test specimens.

11.4 Remove the test specimens from the cell promptly to prevent excessive swelling.

11.5 If other test specimens are to be tested immediately, add liquid until a small amount overflows and proceed to test as in 11.2 and 11.3.

11.6 Since the liquid is constantly being replenished by such a procedure, it may be used until the capacitance at any given temperature increases by 0.1 pF or until its dissipation factor exceeds 0.00001. Empty the cell and refill it with new liquid after testing moist or contaminated specimens.

12. Calculation

12.1 *Permittivity*—Calculate the permittivity as follows:

$$K_p = K_l + \Delta C (t_d/t_s) \times (1/C_v) \quad (1)$$

If $(K_p - K_l)$ is greater than ± 0.1 , use the following equation:

$$K_p = K_l + \frac{\Delta C}{C_v \times (t_s/t_d) - \frac{\Delta C(1 - t_s/t_d)}{K_l}} \quad (2)$$

where:

C_v = $2 \times (0.0088542 A/t_d)$ pF,

K_p = permittivity of specimens,

K_l = permittivity of liquid at test temperature,

ΔC = $(C_2 - C_1)$ = change of capacitance in picofarads when the specimens are inserted (ΔC is positive if the cell capacitance increases, negative if the cell capacitance decreases),

A = area of center capacitor plate, mm² (one face),

t_a = average separation of capacitor plates, mm, and

t_s = average thickness of the two test specimens, mm.

12.2 *Dissipation Factor*—Calculate the dissipation factor as follows:

$$D_p = D_l + (D_c - D_l)(t_d/t_s) \quad (3)$$

which, in cases where D_l is assumed to be zero, simplifies to:

$$D_p = D_c (t_d/t_s) \quad (4)$$

where:

D_p = dissipation factor of specimens,

D_l = dissipation factor of liquid, and

D_c = dissipation factor of combination of specimens and liquid.

12.2.1 Calculate D_l and D_c by one of the following equations, except that at frequencies from about 100 kHz to 1 MHz, change G_0 to G_1 , Q_0 to Q_1 , and D_0 to D_1 , in the equations for D_c only:

Eq 5 when the measuring circuit is a direct-reading conductance meter or bridge,

Eq 6 for a resonance-rise (Q meter) circuit, or

Eq 7 for a direct-reading dissipation factor bridge:

$$D_l = (G_1 - G_0)/\omega C_1 \quad (5)$$

$$D_c = (G_2 - G_0)/\omega C_c \quad (5)$$

$$D_l = C_T(Q_0 - Q_1)/C_l Q_0 Q_1 \quad (6)$$

$$D_c = C_T(Q_0 - Q_2)/C_c Q_0 Q_2 \quad (6)$$

$$D_1 = C_T(D_1 - D_0)/C_l \quad (7)$$

$$D_c = C_T(D_2 - D_0)/C_c \quad (7)$$

where:

G_0 = conductance reading, in picosiemens, of the measuring circuit at balance, before connection of the un-grounded lead to the cell terminal (see 11.2),

G_1 = conductance reading, in picosiemens, of the measuring circuit at balance, after connection of the cell with liquid alone (see 11.2),

G_2 = conductance reading, in picosiemens, of the measuring circuit at balance, after insertion of test specimens (see 11.3),

ω = 2π times the frequency in Hz,

C_l = $(C_0 - C_1)$ = capacitance, pF, of the test cell with liquid alone (see 11.2),

C_c = $(K_l C_v + \Delta C)$, or $K_l C_v$ when ΔC is less than 0.5 pF = effective capacitance of the cell with test specimens and liquid,

C_0 = capacitance reading, pF, of the measuring circuit at balance, after attachment of leads to the circuit terminals but before connection of the ungrounded lead to the cell terminal (see 11.2),

C_1 = capacitance reading, pF, of the measuring circuit at balance, after connection of the ungrounded lead to the terminal of the cell containing liquid alone (see 11.2),

C_2 = capacitance reading, pF, of the measuring circuit at balance, after insertion of test specimens (see 11.3),

C_T = total capacitance, pF, in the measuring circuit or bridge arm at initial balance, before connection of leads to the measuring circuit terminals (see 11.2),

Q_0 = quality factor of the measuring circuit at resonance before connection of the ungrounded lead to the cell terminal (see 11.2),

- Q_1 = quality factor of the measuring circuit at resonance after connection of the ungrounded lead to the terminal of the cell containing liquid alone (see 11.2),
- Q_2 = quality factor of the measuring circuit at resonance, after insertion of test specimens (see 11.3),
- D_0 = dissipation factor reading of the measuring circuit at balance, before connection of the ungrounded lead to the cell terminal (see 11.2),
- D_1 = dissipation factor reading of the measuring circuit at balance, after connection of the ungrounded lead to the terminal of the cell containing liquid alone (see 11.2), and
- D_2 = dissipation factor reading of the measuring circuit at balance, after insertion of test specimens (see 11.3).

13. Report

13.1 Report the following information:

- 13.1.1 Identification of the polyethylene compound or other material tested,
- 13.1.2 Frequency and temperature at which each test was made,
- 13.1.3 Permittivity and dissipation factor of each pair of test specimens tested,
- 13.1.4 Test apparatus employed, and
- 13.1.5 Liquid employed and its permittivity and dissipation factor.

14. Precision and Bias

14.1 The information in 14.2 and 14.3 relates to data obtained with polyethylene.

14.2 *Permittivity*—This test method is capable of providing a very high precision measurement. The repeatability is such that when two consecutive measurements are made under identical conditions on the same test specimens, the two values obtained normally do not differ from each other by more than ± 0.001 ($\pm 0.05\%$). Likewise, when two tests are made on two different sets of test specimens from the same molded sheet, the precision usually is much the same as in the first case. Interlaboratory tests have shown that the reproducibility at the same test frequency and temperature using different testing equipment and different supplies of benzene on the same molded sheets is expected to be within ± 0.002 ($\pm 0.10\%$).

14.3 *Dissipation Factor*—Under the same conditions as stated for permittivity, the expected repeatability for dissipation factor is such that values obtained for remeasured and duplicate samples are expected to be closer than ± 0.00005 . Under the conditions described, the reproducibility of the dissipation factor values of interlaboratory tests are not expected to differ by more than ± 0.0001 from the mean in the vicinity of 0.0001. In general, the dissipation factor precision stated above can be improved five to tenfold by employment of the most sensitive testing apparatus available.

14.4 When the permittivity of the specimen is close to that of the fluid, the bias is expected to be extremely low, since the permittivity of the reference material (benzene) is precisely known.

TEST METHOD B—FLUID DISPLACEMENT METHOD USING TWO FLUIDS

15. Significance and Use

15.1 The use of this test method provides capacitance values from which relative permittivity may be calculated with a greater precision than from other methods which require a precise knowledge of the thickness of the test specimen. This is of benefit when testing very thin films in the order of 2 to 10 μm since the thickness of such films is not easily measured with high precision.

15.2 This test method is applicable for research purposes, for quality control, and purchase specifications.

15.3 Dissipation factor and permittivity obtained by other techniques may require precise dimensional information relating to electrode placement, flatness, parallelism, distance of separation, and so on. This test method does not require such precise data.

15.4 Test Method B, unlike Test Method A, provides reliable permittivity values when used with a fluid with permittivity that is not closely matched to the permittivity of the specimen.

15.5 This test method can provide a reference value of permittivity ($K(\text{ref})$) for the test specimen at a specific test temperature ($T(\text{ref})$) and specific frequency ($f(\text{ref})$). The effects of various parameters (such as voltage, pressure, humidity and exposure) can be studied using other electrode systems as may be appropriate or convenient. The measured effects of these parameters on the capacitance can be used to calculate the changes in permittivity resulting from these effects. For example, the ratio of the capacitance at a selected test condition to the capacitance at the reference conditions multiplied by ($K(\text{ref})$) provides a permittivity value for the selected test condition which is often more precise than that obtained by other techniques. This also reduces the testing time to obtain such information.

15.6 For supplemental information on significance of permittivity and dissipation factor, see Test Methods D 150.

16. Apparatus

16.1 *Bridge*—Any low voltage completely shielded capacitance and dissipation factor bridge conforming to the requirements of Test Methods D 150 may be used. Transformer ratio-arm bridges are recommended because of the simplicity afforded by the grounded guard. The precision obtained depends upon the capacitance resolution (see Note 4) of the bridge. Readability to 0.0001 pF is essential. The sensitivity of the dissipation factor should be 0.00001 or smaller.

NOTE 4—The term resolution is used here to indicate a combination of readability and absence of drift in the bridge readings over the time period of

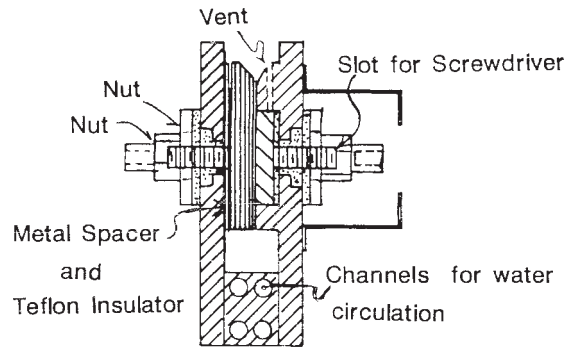

2(a) Cross-Sectional and Schematic View

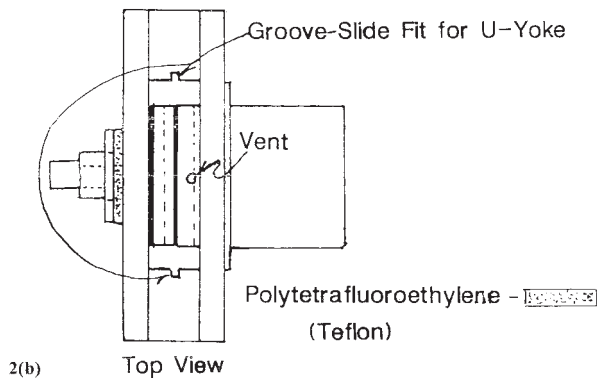

2(b) Top View
FIG. 2 Cell for Test Method B

the measurement. For instance, when the bridge is readable to 0.0001 picofarads, and drift is zero, the theoretical error in permittivity is half as large as when drift of ± 0.00005 pF occurs.

16.2 *Test Cell*—The test cell is a guarded cell with a rigidly mounted electrode system. Sketches of the cross section of this cell are shown in Fig. 2(a) and Fig. 2(b). Fig. 2(b) is a schematic top view of the cell to indicate the grooves which are used to position



FIG. 3 Photograph of Test Cell For Test Method B

the specimen holder. A photograph of the cell showing the grooves appears in Fig. 3. The measuring electrode has a diameter of 25.4 mm and the guard gap is 0.1 mm. All metal (brass) parts are gold plated to a minimum thickness of 20 micrometres (see Note 5). (Replating is essential if the plating is eroded or damaged.) The fluid volume approximates 25 mL. The cell housing is provided with channels for water circulation to maintain close control of temperature of the specimen and the cell parts. Cleaning of the cell requires removal of ten machine bolts and disassembly.

NOTE 5—Recommended plating is an underlayer of electroless nickel 1.3 μm thick overlaid with a standard gold plate 20 μm thick. Cells constructed from stainless steel do not require gold plating.⁷

16.2.1 The largest spacing of electrodes is 1 mm, which provides for testing specimens of 0.85-mm thickness. Smaller spacings are obtained by inserting brass shim pieces of 0.125-mm thickness. Other shim thicknesses are acceptable when appropriate.

16.2.2 *Specimen Holder (U-yoke)*—Fig. 4 shows a sketch of a suitable yoke for holding the specimen taut and flat between the

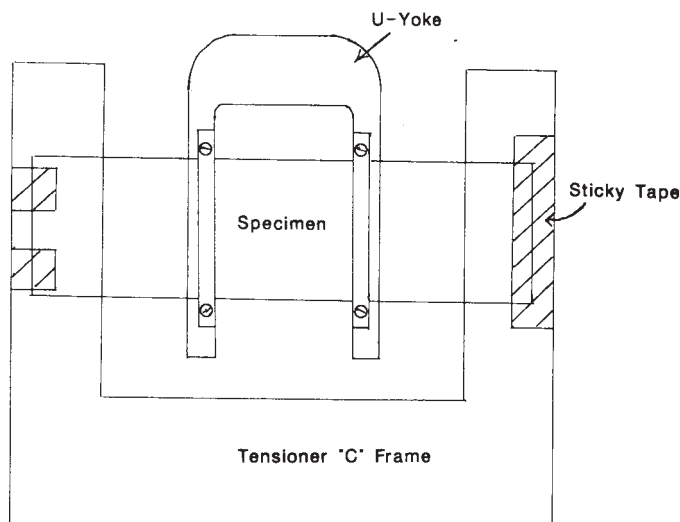

FIG. 4 Installation of Thin Film into U-Yoke Using Tensioner

electrodes. This *jig* or yoke aids in repeated positioning of the specimen at the same position each time it is inserted in the cell. The yoke arms fit into the grooves in the cell assembly shown in Fig. 2(b).

16.2.3 *Tensioner*—For thin films, mounting into the yoke is simplified by the use of a device for maintaining tension on the film as it is mounted into the yoke. Fig. 4 shows a sketch of such a device as a C-shaped frame with inside dimensions larger than the outside dimensions of the U-yoke used.

16.2.4 *Bath*—A temperature controlled bath is required to provide the water for circulation through the cell assembly. Equip this bath with temperature controllers capable of maintaining water temperature uniform to $\pm 0.05^\circ\text{C}$.

16.2.4.1 Provide the bath with a circulating pump to transport the water at a velocity adequate to provide efficient heat transfer to the cell assembly.

16.2.5 *Conditioning Rack*—to support and separate specimens during conditioning.

16.2.6 *Liquid Degassing*—See Test Method D 831. Use the apparatus for gas content measurement with oil trap replaced by a vacuum desiccator to hold the test cell. Add a liquid nitrogen trap between the vacuum desiccator and the vacuum pump.

17. Fluids

17.1 *General*—The requirements of the fluids for Test Method B are similar to the requirements of fluids used for Test Method A (see Section 7). For Test Method B there is no advantage associated with matching the permittivity of the fluid to that of the specimen, but there is an advantage to using two fluids with a large difference between their permittivities. A liquid with a low dissipation factor is more useful for Test Method B than it is for Test Method A, since, with ultra-thin films especially, a large ratio exists between the thickness of the test specimen and the gap between the electrodes. This ratio dilutes the dissipation factor of the specimen, and decreases the precision of the measurements. Comparisons of dissipation factor measured by other more conventional techniques are recommended to judge the suitability of fluids.

17.2 *Candidate fluids*—Silicone fluid of viscosity 1 to 2 centistokes ($1 - 2 \times 10^{-6} \text{ m}^2/\text{s}$) is satisfactory for use with many materials including polyolefins, polytetrafluoroethylene, polyethylene terephthalate, and polycarbonates. Technical grade heptane is acceptable for PTFE and many polyester polymers. Perfluorinated liquids are excellent since they are essentially insoluble in most organic polymers.

17.3 Avoid the use of fluids that swell or otherwise affect the properties of a specimen.

17.4 *Reclamation of Liquids*—Liquids may be reused until there is a change in the dissipation factor of the liquid which exceeds 0.00001 from its previously observed value. Often the number of times that fluid may be reused may be greatly increased by removing particulate contaminant by filtering through a fritted glass filter. If moisture absorption is a problem, the liquid can be stored over a desiccant. Although phosphorus pentoxide is a suitable desiccant for benzene, it may not be suitable for other liquids.

⁷ Construction drawings of this cell are contained in a research report available from ASTM Headquarters, 100 Barr Harbor Drive, West Conshohocken, PA 19428. Request RR: D09-1031 and ADJ1531.

17.5 In principle there is no reason why viscous liquids are not acceptable. However, the time required for such fluids to fill the guard gap and the space behind the measuring electrode may be large. Special cleaning procedures are required to remove such viscous liquids.

17.6 *Characterization of Liquids*—In principle, the relative permittivity and the dissipation factor of any liquid may be determined using this test method. Measure first the capacitance and dissipation factor of the cell with air as the dielectric, and then repeat the measurement with the cell filled with a liquid. Use the data to compute the relative permittivity and dissipation factor of the liquid (see 21.5 and Note 6).

NOTE 6—Test Method D 924 contains additional methods for the measurement of dielectric properties of fluids.

18. Sampling

18.1 Sample as directed by applicable material specification, but observe the following precautions:

18.1.1 Handle samples and specimens with care so as to minimize any possibility of surface contamination or dust collection.

18.1.2 Store and transport samples or specimens in clean polyethylene bags.

18.1.3 Cut thick films to size, wash with detergent, rinse with distilled water, and dry.

18.1.4 Cut thin films to size, place into a U-yoke, then wash with a detergent, rinse with distilled water, and dry.

19. Test Specimens

19.1 *Dimensions*—Use thick, self-supporting material approximately 37 by 47 mm. Use thin, flexible material approximately 37 mm wide by 120 to 150 mm long to provide excess length for handling during fitting into the U-yoke. The thickness will be determined by the test.

19.2 *Assembly and Conditioning*—Assemble specimens into U-yokes before conditioning according to 10.1. During assembly use tweezers to avoid surface contamination. For thin films, use a tensioner (see 16.2.3) as an aid in holding the specimen flat and taut during assembly. Fasten the extended ends of the thin film specimen to the tensioner using pressure sensitive tape. Next, place the tines of the U-yoke into the throat of the tensioner and attach the thin film to the U-yoke using edge clamps or staples as appropriate for the design of the U-yoke used. Finally, cut the excess thin film from the U-yoke, exercising care to not contaminate the surfaces of the specimen prior to testing.

20. Electrode Gap Considerations

20.1 In theory, the equations for use with Test Method B do not assume that the spacing between electrodes is the same with fluid 1 as with fluid 2. In fact, for tests with two liquids it is sometimes convenient to use two cells since the cleaning of the cell between the tests is eliminated. When only one cell is available, it is convenient to use air as the first fluid since cleaning is not needed between the tests with the two fluids.

21. Procedure

21.1 *Selection of Fluids:*

21.1.1 *General Considerations*—The material specification may define the fluids used. If not, air and silicone fluid (see Sections 7 and 17) are usually good choices. If benzene is used, refer to Section 7. If no prior information is available about compatibility, make an immersion test in a bath or beaker at the temperature specified for the testing to observe the effect of the fluids on the specimen. A minimum immersion time of 1 h is suggested. Crude mechanical tests are usually sufficient to show whether the specimen is sufficiently stable for an initial test in the cell.

21.2 Select the desired electrode separation. Generally this is 0.125 mm for specimens 0.075 mm or less in thickness, 0.25 mm in specimens 0.076 mm to 0.20 mm thickness, and approximately 1.25(t) for specimens of thickness t greater than 0.20 mm.

21.3 Adjust the electrode separation of the cell to the selected value.

21.4 Prepare the cell using the recommended cleaning procedure of 11.1. Set the temperature control system to the specified test temperature and start the water circulation. If test temperature is not specified, use $23 \pm 0.1^\circ\text{C}$. Record the temperature of the fluid (air or liquid) in the test cell. Do not start electrical measurements until the temperature is at the specified temperature and maintained at $\pm 0.05^\circ\text{C}$.

21.5 Even when air is *not* one of the fluids, a measurement of the empty cell (that is, air alone) is useful as a measure of cleanliness (see 11.1). Moreover, the relative permittivity of the liquid is used in the calculations, and it may be obtained by taking the ratio of the capacitance of the cell filled with the liquid to the capacitance of the empty cell.

21.6 Connect the leads from the bridge to the cell and balance. If the dissipation factor exceeds 0.00001 for a cell containing only dry air, it is necessary to disconnect the cell and clean it. Repeat until the dissipation factor is less than 0.00001. Then record the values of C_1 and D_1 .

21.7 Insert the specimen in the air-filled cell. Measure capacitance and dissipation factor after thermal equilibrium has been established. Record the values of C_{1x} and D_{1x} and the temperature of the cell to the nearest 0.1°C .

21.8 Remove the specimen from the cell. Fill the cell with the fluid of choice until the level is above the wedge-shaped top of the electrodes. Check the cell temperature; it should be the same as in 21.7 within 0.1°C . Measure the capacitance and dissipation factor. Record the values as C_2 and D_2 .

21.9 Insert the specimen into the cell. Measure capacitance and dissipation factor. Check the cell temperature. It should be the

same as in 21.7 within 0.1°C. Record the values for C_{2x} and D_{2x} and the temperature.

21.10 Remove the specimen from the cell immediately after this testing.

21.11 If a second liquid is used (and the two cell technique of 20.1 is not used), clean the cell and the test specimen before tests with the second liquid are made. Clean the specimen as follows (See Note 7):

21.11.1 Allow liquid 1 to drain from the specimen (including the U-yoke). Lightly blot remnant drop.

21.11.2 Using tweezers, dip the specimen into a beaker or bath containing fresh liquid 2. Use gentle agitation followed by draining.

21.11.3 Redip into fresh, clean liquid 2, using the procedure in 21.11.2.

21.11.4 Repeat at least three times using fresh, clean liquid 2 each time.

21.11.5 The cell can be cleaned in a similar manner, by repeated flushing with liquid 2 following each flushing with a thorough draining.

NOTE 7—The instructions above for cleaning apply to low viscosity liquids such as benzene or 1 cSt silicone fluid. Use other appropriate procedures for more viscous liquids such as cable oils or transformer oils.

21.12 Fill the cell with the second liquid and proceed as in 21.8 through 21.10. Record the values for C_3 , D_3 , C_{3x} , and D_{3x} .

22. Calculation

22.1 The equations for the computation of relative permittivity, dissipation factor, capacitance, and thickness of the region measured on the specimen are as follows: For the case where air is the first fluid (Case 1), use equations 8, 9, 12, 14, and 15. For the case where two fluids both with permittivities different from 1.000 are used, use equations 10, 11, 13, 14, and 15.

$$K_x = \frac{K_2 C_2 C_{2x} \Delta C_1 - K_2 C_1 C_{1x} \Delta C_2}{C_2 C_{2x} \Delta C_1 - K_2 C_1 C_{1x} \Delta C_2} \quad (8)$$

$$K_x = 1 + \frac{K_2 - 1}{K_2} \left(\frac{K_2 C_1 C_{1x} \Delta C_2}{C_2 C_{2x} \Delta C_1} \right) \quad (9)$$

$$K_x = \frac{K_3 K_2 C_2 C_{2x} \Delta C_3 - K_3 K_2 C_3 C_{3x} \Delta C_2}{K_3 C_2 C_{2x} \Delta C_3 - K_2 C_3 C_{3x} \Delta C_2} \quad (10)$$

$$K_x = K_2 + \frac{K_3 - K_2}{K_3} \left(\frac{1 - K_3 C_2 C_{2x} \Delta C_3}{K_2 C_3 C_{3x} \Delta C_2} \right) \quad (11)$$

$$C_x = \frac{(K_2 - 1) (C_1 C_{1x} C_2 C_{2x})}{C_2 C_{2x} \Delta C_1 - K_2 C_1 C_{1x} \Delta C_2} \quad (12)$$

$$C_x = \frac{(K_3 - K_2) (C_2 C_{2x} C_3 C_{3x})}{K_2 C_3 C_{3x} \Delta C_2 - K_3 C_2 C_{2x} \Delta C_3} \quad (13)$$

$$\tan \delta_x = C_x \quad (14)$$

$$t = K_x \epsilon_0 A / C_x \quad (15)$$

where:

$\tan \delta_x$ = dissipation factor of the test specimen,

C_x = capacitance of the test specimen,

K_2 = permittivity of the first liquid,

K_3 = permittivity of the second liquid,

K_x = permittivity of the specimen,

ΔC_1 = the change in capacitance on insertion of the specimen into the air filled cell,

ΔC_2 = the change in capacitance on insertion of the specimen in the first liquid, and

ΔC_3 = the change in capacitance on insertion of the specimen into the second liquid.

f is used as a substitute for 1 or 2 or 3 wherever the results obtained in any of the fluids can be used for the calculation. Thus separate estimates of $\tan \delta$ may be calculated from Eq 12 for each fluid used.

ϵ_0 = a constant which has a value of 8.8542×10^{-3} when areas are expressed in mm^2 , and capacitances in pF,

A = the effective area (in mm^2) of the guarded electrode as defined in Appendix X2 of Test Method D 150, and

t = the specimen thickness in mm.

The other quantities (C_1 , C_{1x} , C_2 , C_{2x} , D_1 , D_{1x} , D_2 , and D_{2x}) are defined in the procedure section.

23. Report

23.1 Report the following information:

23.1.1 Identification of the specimen material,

23.1.2 The frequency and temperature at which each test was made,

23.1.3 The test apparatus used,

- 23.1.4 The cell used,
- 23.1.5 The fluids used,
- 23.1.6 The relative permittivity of the fluids used,
- 23.1.7 The temperature of the water bath,
- 23.1.8 The permittivity and dissipation factor of each specimen tested,
- 23.1.9 The electrode gap,
- 23.1.10 The electrical thickness of each specimen, determined in each fluid, and
- 23.1.11 Any indication of interaction between the fluids used and the electrical, mechanical, or physical properties of the specimen.

24. Precision and Bias

24.1 *Permittivity*—No interlaboratory tests have been performed. Independent tests within several laboratories (1) (2) (3) (4) (5) (6) (7)⁸ have demonstrated that when equipment with the highest resolution available is used to measure films with thicknesses in the 3 to 10 μm range, the results suggest that the interlaboratory standard deviation for tests of permittivity should not exceed 0.5 % of the mean. With respect to bias, a one laboratory comparison (3) of the same 20 μm specimens measured with evaporated gold electrodes and with the 2 fluid method showed the permittivity to be 1.7 % higher with evaporated gold than with 2 fluid. Edge corrections could possibly account for one-third of this discrepancy. Clamping of the film by the electrode would be expected to cause an error in the same direction.⁹

24.2 Very little data are available on the maximum thickness of material that may be measured using this test method.

24.3 *Thickness Estimation*—Those familiar with the test method state that the precision of the estimate of thickness is about the same as that of permittivity.

24.4 The precision depends upon the electrode gap used and the capacitance resolution of the bridge. Estimates of these effects are given in Table 2.

TABLE 2 Effect of Gap Size on the Possible Error for Test Method B

NOTE 1—Assumptions: Permittivities of the two fluids are 1.000 and 2.300. Capacitance resolution is either 0.001 pF, or 0.01 pF.

NOTE 2—The values which relate to 0.01 are underlined. The temperature is absolutely constant.

NOTE 3—Permittivity of the specimen is indicated in [].

| Specimen Thickness | Gap | | |
|--------------------|-------------------|--------------------|--------------------|
| | 5 mil (127 μm) | 2 mil (50.8 μm) | 1 mil (25.4 μm) |
| 0.05 mil (1.25 μm) | 0.34 % [3.0] | 0.053 % [3.0] | |
| 0.05 mil (1.25 μm) | 3.24 % [3.0] | | |
| 0.25 mil (6.25 μm) | 0.070 % [3.0] | | |
| 0.05 mil | 0.42 % [2.6] | 0.007 % [2.6] | |
| 0.25 mil (6.25 μm) | 0.69 % [3.0] | | |
| 0.05 mil | 0.018 % [2.2] | 0.003 % [2.2] | 0.001 % [2.2] |

25. Keywords

25.1 dielectric constant; dissipation factor; fluid displacement (single fluid); fluid displacement (two fluid); immersion method; permittivity

⁸ The boldface numbers in parentheses refer to the list of references at the end of this standard.

⁹ Results of additional tests made at one laboratory (3) are also included in a research report available from ASTM Headquarters, 100 Barr Harbor Drive, West Conshohocken, PA 19428. Request RR: D09-1031.

REFERENCES

- (1) De Luca, H. A., Campbell, W. B., and Maass, D., “Measurement of the Dielectric Constant of Cellulose”, Canadian Journal of Research, Vol. 10, Aug. 1938, p. 273.
- (2) Endicott, H. S., and Springgate, W. F., “Measurement of the Dielectric Constant of Thin Films”, 1950 Annual Report, Conference on Electrical Insulation, p. 43.
- (3) Endicott, H. S., and McGowan E. J., “Measurement of Permittivity and Dissipation Factor Without Attached Electrodes”, 1960 Annual Report, Conference on Electrical Insulation, NAS-NRC Publication 842, National Academy of Sciences—National Research Council, Washington DC, 1961, pp. 19–30.
- (4) Harris, W. P., and Scott, A. H., “Precise Measurement of Dielectric Constant by the Two Fluid Technique”, 1962 Annual Report, *ibid.* NAS-NRC Publication 1080, 1963, pp. 51–53.
- (5) Hazen, T., “Recent Improvements in Methods of Measuring the Dielectric Constant and Loss Characteristics of Polyethylene for Primary Insulation of Communication Cables”, Proceedings, 13th Annual Wire and Cable Symposium, Atlantic City, NJ, Dec. 1964.
- (6) Oneal, Jr., G., “Design of a Two Fluid Cell for Measurement of Permittivity and Dissipation Factor of Thin Films”, IEEE Conference Paper C72-7, New York, 1972.
- (7) Endicott, H. S., “Guard-Gap Correction for Guarded-Electrode Measurements and Exact Equations for the Two-Fluid Method of Measuring Permittivity and Loss”, Journal of Testing and Evaluation JTEVA, Vol. 4, No. 3, May 1976, pp. 188–195.

ASTM International takes no position respecting the validity of any patent rights asserted in connection with any item mentioned in this standard. Users of this standard are expressly advised that determination of the validity of any such patent rights, and the risk of infringement of such rights, are entirely their own responsibility.

This standard is subject to revision at any time by the responsible technical committee and must be reviewed every five years and if not revised, either reapproved or withdrawn. Your comments are invited either for revision of this standard or for additional standards and should be addressed to ASTM International Headquarters. Your comments will receive careful consideration at a meeting of the responsible technical committee, which you may attend. If you feel that your comments have not received a fair hearing you should make your views known to the ASTM Committee on Standards, at the address shown below.

This standard is copyrighted by ASTM International, 100 Barr Harbor Drive, PO Box C700, West Conshohocken, PA 19428-2959, United States. Individual reprints (single or multiple copies) of this standard may be obtained by contacting ASTM at the above address or at 610-832-9585 (phone), 610-832-9555 (fax), or service@astm.org (e-mail); or through the ASTM website (www.astm.org).