



Standard Test Methods for Film-Insulated Magnet Wire¹

This standard is issued under the fixed designation D 1676; the number immediately following the designation indicates the year of original adoption or, in the case of revision, the year of last revision. A number in parentheses indicates the year of last approval. A superscript epsilon (ε) indicates an editorial change since the last revision or reapproval.

1. Scope

1.1 These test methods cover procedures for testing film-insulated magnet wire that is used in electrical apparatus. These test methods are intended primarily for the evaluation of the electrical insulating materials used. The intent is that these test methods be used, except where modified, by individual specifications for particular applications.

1.2 These test methods present different procedures for evaluating given properties of round, rectangular or square, copper or aluminum film-insulated magnet wire.

1.3 The values stated in inch-pound units are the standard. The SI units in parentheses are provided for information only.

1.4 The test methods appear in the following sections:

	Sections
Bond Strength	4-12
Burnout (AC Overload Resistance)	13-21
Chemical Resistance	22-28
Coefficient of Friction	29-37
Continuity, DC High Voltage	38-45
Continuity, DC Low Voltage	46-53
Completeness of Cure	54-60
Cut-Through Temperature (Thermoplastic Flow)	61-68
Dielectric Breakdown AC Voltage	69-75
Dielectric Breakdown AC Voltage after Bending	76-82
Dielectric Breakdown AC Voltage at Elevated Temperatures	83-89
Dielectric Breakdown AC Voltage after Conditioning in Refrigerant Atmosphere	90-99
Dimensional Measurement	100-106
Dissipation Factor Measurement	107-114
Electrical Resistance	115-121
Elongation	122-129
Extractables, Refrigerant	130-140
Film Adherence and Flexibility	141-148
Formability:	
a) Elastic Ratio	152
b) Low Stress Elongation	153
c) Spring Back	154-155
Heat Shock	156-162
Oiliness	163-169
Scrape Resistance, Unidirectional	170-177
Solderability	178-185
Resistance to Insulating Liquids and Hydrolytic Stability	186-195

1.5 *This standard does not purport to address all of the safety concerns, if any, associated with its use. It is the responsibility of the user of this standard to establish appropriate*

and health practices and determine the applicability of regulatory limitations prior to use. Specific hazard statements are given in 9.5, 19.1, 19.3, 19.8, 52.1, 58, 59.1, 74.1, 112.1, 135.4, and 182.3.

NOTE 1—This test method is related to IEC 60851. Since both methods contain multiple test procedures, many procedures are technically equivalent while others differ significantly.

2. Referenced Documents

2.1 ASTM Standards:

- A 228/A 228M Specification for Steel Wire, Music Spring Quality²
- B 3 Specification for Soft or Annealed Copper Wire³
- B 43 Specification for Seamless Red Brass Pipe, Standard Sizes⁴
- B 193 Test Method for Resistivity of Electrical Conductor Materials³
- B 279 Test Method for Stiffness of Bare Soft Square and Rectangular Copper and Aluminum Wire for Magnet Wire Fabrication³
- B 324 Specification for Aluminum Rectangular and Square Wire for Electrical Purposes³
- B 609/B 609M Specification for Aluminum 1350 Round Wire, Annealed and Intermediate Tempers, for Electrical Purposes³
- D 149 Test Method for Dielectric Breakdown Voltage and Dielectric Strength of Solid Electrical Insulating Materials at Commercial Power Frequencies⁵
- D 150 Test Methods for AC Loss Characteristics and Permittivity (Dielectric Constant) of Solid Electrical Insulation⁵
- D 374 Test Methods for Thickness of Solid Electrical Insulation⁵
- D 877 Test Method for Dielectric Breakdown Voltage of Insulating Liquids Using Disk Electrodes⁶
- D 1533 Test Methods for Water in Insulating Liquids by Coulometric Karl Fischer Titration⁶
- D 1711 Terminology Relating to Electrical Insulation⁵

¹ These test methods are under the jurisdiction of ASTM Committee D09 on Electrical and Electronic Insulating Materials and are the direct responsibility of Subcommittee D09.10 on Magnet Wire Insulation.

Current edition approved Apr. 10, 2003. Published June 2003. Originally approved in 1959. Last previous edition approved in 2002 as D 1676-02.

² Annual Book of ASTM Standards, Vol 01.03.

³ Annual Book of ASTM Standards, Vol 02.03.

⁴ Annual Book of ASTM Standards, Vol 02.01.

⁵ Annual Book of ASTM Standards, Vol 10.01.

⁶ Annual Book of ASTM Standards, Vol 10.03.

- D 2475 Specification for Felt⁷
- D 2519 Test Method for Bond Strength of Electrical Insulating Varnishes by the Helical Coil Test⁸
- D 5423 Specification for Forced-Convection Laboratory Ovens for Evaluation of Electrical Insulation⁸
- E 4 Practices for Force Verification of Testing Machines⁹
- E 6 Terminology Relating to Methods of Mechanical Testing⁹
- E 8 Test Methods of Tension Testing of Metallic Materials⁹
- E 220 Test Method for Calibration of Thermocouples by Comparison Techniques¹⁰
- E 1356 Test Method for Assignment of the Glass Transition Temperatures by Differential Scanning Calorimetry or Differential Thermal Analysis¹¹
- E 1545 Test Method for Assignment of the Glass Transition Temperature by Thermomechanical Analysis¹¹
- 2.2 *Other Documents:*
- Federal Specification CCCM-911 for Bleached Muslin¹²
- IEC 60851 Methods of Test for Winding Wire¹²

3. Terminology

3.1 Definitions:

3.1.1 *conductor, n*—a wire or combination of wires not insulated from each other, suitable for carrying electric current.

3.1.2 *magnet wire, n*—a metal electrical conductor, covered with electrical insulation, for use in the assembly of electrical inductive apparatus such as coils for motors, transformers, generators, relays, magnets, etc.

3.1.3 For definition of other terms used in this test method refer to Terminology D 1711.

3.2 Definitions of Terms Specific to This Standard:

3.2.1 *film coating, n*—cured enamel coating.

3.2.2 *film insulated wire, n*—a conductor insulated with a film coating.

BOND STRENGTH OF ROUND FILM-INSULATED SELF-BONDING MAGNET WIRE BY THE HELICAL COIL TEST

4. Scope

4.1 This test method covers the determination of the bond strength of a self-bonding outer coating on round film-insulated magnet wires (AWG 14 through 44). Both thermal and solvent bonding methods are defined.

5. Terminology

5.1 Definitions of Terms Specific to This Standard:

5.1.1 *bond strength, n*—a measure of the force required to separate surfaces which have been bonded together.

5.1.1.1 *Discussion*—For magnet wire which has been self bonded or varnish treated, the bond strength is reported as the force required to break a test specimen in flexure.

6. Summary of Test Method

6.1 Flexural strength tests are made on bonded helical coils to determine the force required to break the coil under specified conditions.

7. Significance and Use

7.1 Bond strength values obtained by flexural tests can provide information with regard to the bond strength of a particular self-bonding outer coating in combination with a particular round film-insulated magnet wire when measured under conditions described in this test method.

8. Apparatus

8.1 *Testing Machine*—Tensile testing machines used for bond strength test shall conform to the requirements of Practices E 4.

8.2 *Test Fixture*—The test fixture shall conform to the test fixture for bond strength tests required by Test Method D 2519.

8.3 *Mandrel Holder*—The mandrel holder shall be a metal block of sufficient size and thickness with a hole capable of supporting the winding mandrel in a vertical position during the bonding cycle of the helical coil.

8.4 *Winding Tensions*—The winding tensions are listed in Table 1.

8.5 *Bonding Weights*—Bonding weights (listed in Table 1) should be made with a hole through the center to allow the weight to slip freely over the winding mandrel and load a helical coil during bonding of coil.

8.6 *Forced-Air Oven*—See Specification D 5423.

TABLE 1 Helical Coil Bond Parameters

Wire Size, AWG	Mandrel Diameter ^A		Recommended Winding Tension		Bond Weights ^A	
	in.	mm	g	N	g	N
44	0.011	0.28	2.5	0.025	0.80	0.008
43	0.011	0.28	2.5	0.025	0.80	0.008
42	0.016	0.41	5.0	0.50	1.60	0.016
41	0.016	0.41	5.0	0.50	1.60	0.016
40	0.022	0.56	10.0	0.098	3.15	0.031
39	0.022	0.56	10.0	0.098	3.15	0.031
38	0.022	0.56	10.0	0.098	3.15	0.031
37	0.032	0.81	20.0	0.196	6.30	0.062
36	0.032	0.81	20.0	0.196	6.30	0.062
35	0.032	0.81	20.0	0.196	6.30	0.062
34	0.044	1.12	40.0	0.392	12.5	0.123
33	0.044	1.12	40.0	0.392	12.5	0.123
32	0.044	1.12	40.0	0.392	12.5	0.123
31	0.063	1.60	80.0	0.785	25.0	0.245
30	0.063	1.60	80.0	0.785	25.0	0.245
29	0.063	1.60	80.0	0.785	25.0	0.245
28	0.088	2.24	160.0	1.569	50.0	0.490
27	0.088	2.24	160.0	1.569	50.0	0.490
26	0.088	2.24	160.0	1.569	50.0	0.490
25	0.124	3.15	315.0	3.089	100.0	0.981
24	0.124	3.15	315.0	3.089	100.0	0.981
23	0.124	3.15	315.0	3.089	100.0	0.981
22	0.177	4.50	630.0	6.178	200.0	1.961
21	0.177	4.50	630.0	6.178	200.0	1.961
20	0.177	4.50	630.0	6.178	200.0	1.961
19	0.248	6.30	1250.0	12.258	400.0	3.923
18	0.248	6.30	1250.0	12.258	400.0	3.923
17	0.248	6.30	1250.0	12.258	400.0	3.923
16	0.354	8.99	2500.0	24.517	800.0	7.845
15	0.354	8.99	2500.0	24.517	800.0	7.845
14	0.354	8.99	2500.0	24.517	800.0	7.845

^A± 2 % on all mandrels and bond weights.

⁷ Annual Book of ASTM Standards, Vol 07.01.

⁸ Annual Book of ASTM Standards, Vol 10.02.

⁹ Annual Book of ASTM Standards, Vol 03.01.

¹⁰ Annual Book of ASTM Standards, Vol 14.03.

¹¹ Annual Book of ASTM Standards, Vol 14.02.

¹² Available from Standardization Documents Order Desk, Bldg. 4 Section D, 700 Robbins Ave., Philadelphia, PA 19111-5094, Attn: NPODS.

9. Test Specimen Preparation

9.1 Select the appropriate mandrel from Table 1, spray it with a suitable release agent (fluorocarbon or silicone spray is adequate), and allow it to dry. Carefully wind onto the prepared mandrel a length of wire, long enough to wind a helical coil at least 3 in. (76 mm) long. The winding tension shall be as prescribed in Table 1. Ensure that the coil is wound without space between turns.

9.2 Prepare six or more coils from each wire sample.

9.3 *Thermal Bonding*—Mount the mandrel supporting the coil vertically in the mandrel holder and loaded with the bonding weight specified in Table 1. Place the mandrel holder and coil into a forced-air oven at a specified temperature for a specified time, after which the assembly is removed from the oven and cooled to room temperature. Remove the coil from the mandrel and inspect the coil for breaks or physical damage prior to testing.

9.4 *Solvent Bonding*—After winding, immerse the coil and mandrel into the specified solvent for 5 s. Immediately thereafter, secure the mandrel supporting the coil in the mandrel holder and load the coil with the bonding weight specified in Table 1. Dry the coils for 1 h at room temperature. Carefully remove the coils from the mandrels and further dry in a forced air oven for 15 ± 2 min at $100 \pm 3^\circ\text{C}$ (unless otherwise specified). Cool the coil to room temperature, inspect for breaks or physical damage, and test.

9.5 *Resistance Bonding*—Mount the mandrel supporting the coil vertically in a mandrel holder and loaded with the bonding weight specified in Table 1. Energize the coil with enough current and time to allow bonding. Remove the coil from the mandrel and inspect for breaks or physical damage, and test. Specific bonding conditions shall be agreed upon between the manufacturer and the user. (**Warning**—*Lethal voltages are a potential hazard during the performance of this test. It is essential that the test apparatus, and all associated equipment electrically connected to it, be properly designed and installed for safe operation. Solidly ground all electrically conductive parts which it is possible for a person to contact during the test. Provide means for use at the completion of any test to ground any parts which were at high voltage during the test or have the potential for acquiring an induced charge during the test or retaining a charge even after disconnection of the voltage source. Thoroughly instruct all operators as to the correct procedures for performing tests safely. When making high voltage tests, particularly in compressed gas or in oil, it is possible for the energy released at breakdown to be sufficient to result in fire, explosion, or rupture of the test chamber. Design test equipment, test chambers, and test specimens so as to minimize the possibility of such occurrences and to eliminate the possibility of personal injury. If the potential for fire exists, have fire suppression equipment available.*)

10. Procedure

10.1 Use a rate of loading such that the duration of the test shall be greater than the full-scale response time of the load recording instrument.

10.2 Prepare sufficient specimens to obtain six data points for each wire sample. One or more of the specimens may be destroyed in adjusting the rate of loading.

10.3 Break specimens according to the test procedures described in Test Method D 2519.

10.4 Tests at other than room temperature can be performed, if desired, using an insulated heat-resistant enclosure, designed to fit around the test fixture and in the stress strain analyzer. Place the specimens in the fixture in the oven for 15 min but not more than 30 min after the oven has recovered to the set temperature $\pm 2^\circ\text{C}$. Break the specimens according to the test procedures described in Test Method D 2519. The specified test temperature and minimum bond strength shall be agreement upon between the manufacturer and the user.

11. Report

11.1 Report the following:

11.1.1 Identification of size, build and type of insulation used,

11.1.2 Heat or solvent bonding (including temperature or type of solvent, or both),

11.1.3 Test temperature, and

11.1.4 A table listing the individual values in pounds, grams or newtons of bond strength and their averages.

12. Precision and Bias¹³

12.1 In comparing two averages of six observations, the differences should not exceed the critical difference in Table 2, in 95 out of 100 cases when all of the observations are taken by the same well-trained operator using the same piece of test equipment and specimens randomly drawn from the same sample of material.

12.2 *Precision*—Two averages of observed values should be considered significantly different at the 95 % probability level if the difference equals or exceeds the critical differences listed in Table 2.

12.3 *Bias*—This test method has no bias because the value of bond strength is determined solely in terms of this test method.

BURNOUT (AC OVERLOAD RESISTANCE)

13. Scope

13.1 This test method and equipment described herein is used to determine the ac overload resistance of 18 AWG heavy build film-insulated round copper magnet wire by measuring

¹³ Supporting data are available from ASTM International Headquarters. Request RR: D09-1007.

TABLE 2 Critical Differences, Percent of Average Pounds to Break^A

Number of Observations in each Average	Single-Operator Precision	Within-Laboratory Precision	Between-Laboratory Precision
6	10	11	12

^AThe critical differences were calculated using $t = 1.960$, which is based on infinite degrees of freedom

the time to obtain a dielectric failure when subjected to a step-wise increase in AC overload current.

14. Terminology

14.1 *Definitions of Terms Specific to This Standard:*

14.1.1 *burnout (of magnet wire), n*—the time required for dielectric failure to occur between wires of a twisted pair as a result of heating due to controlled ac overload current.

14.1.2 *one twist (dielectric twist specimen), n*—one 360° revolution of the head of the dielectric twist maker.

15. Summary of Test Method

15.1 A controlled current (I) is passed through both strands of a film-insulated magnet wire twisted pair. The resistance heating of this specimen due to the current (I) will result in thermal degradation of the film. When the level of degradation is sufficient for a 50-mA current at 130 ± 10 Vac to pass through the film, burnout occurs. The burnout is reported in seconds (t).

16. Significance and Use

16.1 The film-insulated magnet wire current burnout tester is designed to rate the performance of various wire insulation under higher than normal operating temperatures brought about by current overloads. The seconds (t) to burnout should relate to the performance of the film coating under overload conditions in actual field operations.

16.2 Test results will allow the film-insulated magnet-wire user to analyze the relative performance of various magnet-wire products.

16.3 Test condition #1 was developed for faster and more reproducible testing results, especially for product conformance testing.

16.4 Test condition #2 was developed to provide the greatest relative product performance differentiation. Calculation of an Overload Figure of Merit (OFM) is possible using this procedure and is described in 19.9.

17. Apparatus

17.1 *Twist Fabricator*, that can duplicate in function the one pictured in Fig. 1.¹⁴

17.2 *Three-Pound Load Weight*, necessary for use in conjunction with the twist fabricator.

17.3 A means of mechanically stripping the legs of the twisted-pair specimen to a clean bright copper finish.

17.4 *Small Vise or Pair of Needle-Nose Pliers*, for stabilizing the specimen during the stripping operation, and removal of the test specimen from the tester.

17.5 *Burnout Tester*, see Fig. 2.¹⁵

18. Test Specimen Preparation

18.1 Using the twist fabricator and a 3-lb load weight, form a 30-in. (76-cm) length of 18 AWG heavy-build film-insulated round copper magnet wire into a U-shape and twist the two legs together. A total of 8 or 16 twists are required. Cut the loop and carefully hand-form the ends for easy placement in the burnout tester.

18.2 There shall be no sharp bends in the specimen or damage to the insulation. After ensuring that the legs are the

¹⁴ Suitable testers are available from A/Z Tech, Inc., 2701 South Coliseum Boulevard, Suite 1228, Fort Wayne, IN 46803; Ampac International, 1118 Cedar St, Fort Wayne, IN 46803; or Byrne Harnessed Electronics, Inc., 16726 150th Ave., Spring Lake, MI 49456.

¹⁵ Test equipment available from Byrne Harnessed Electronics, Inc., 16726 150th Ave., Spring Lake, MI 49456.

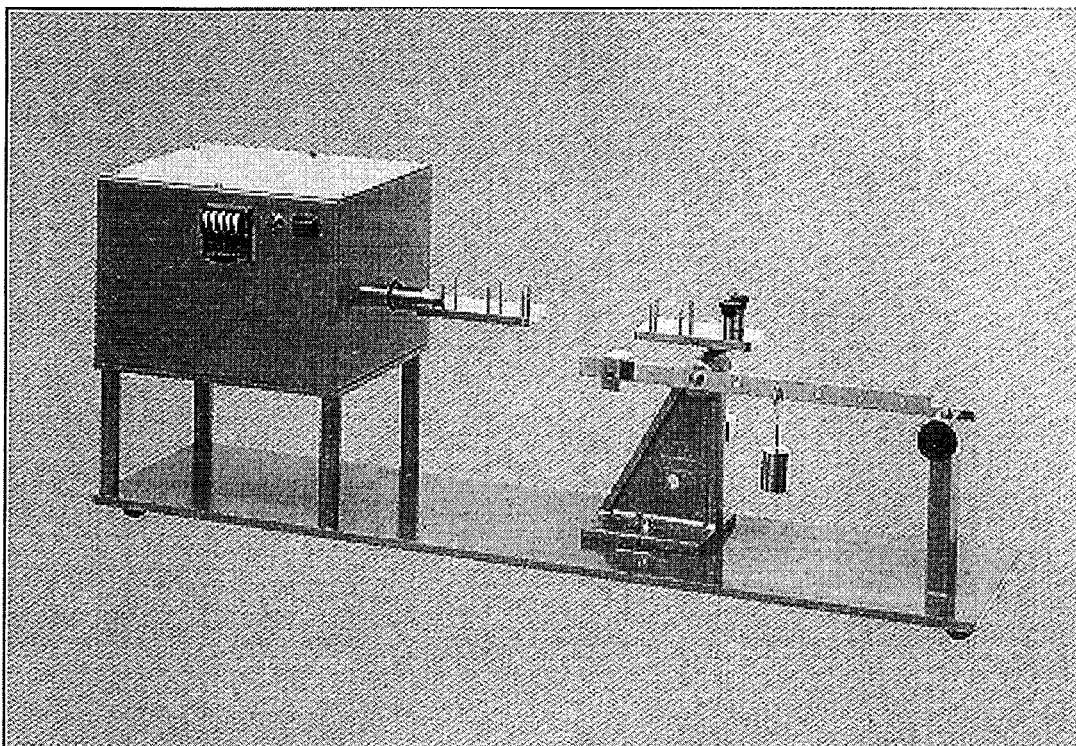
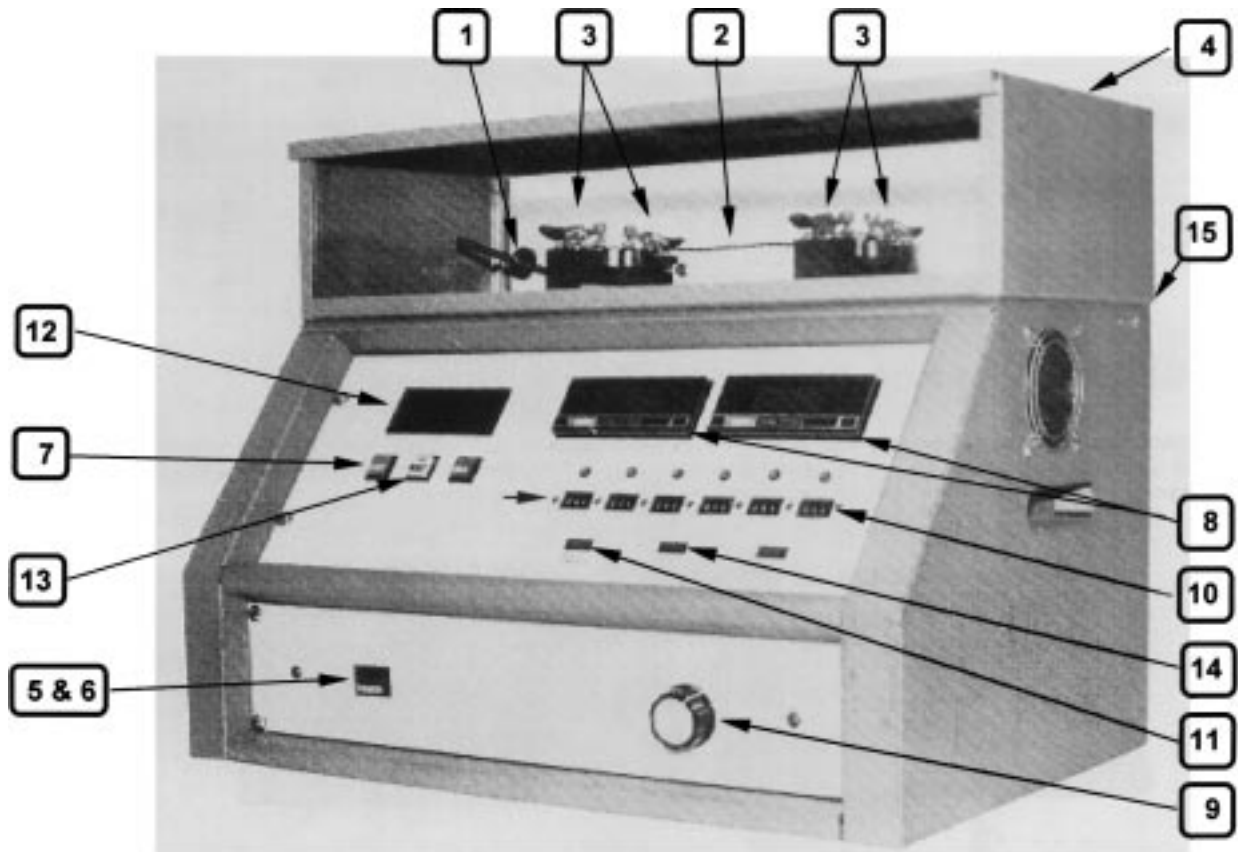

FIG. 1 Twist Fabricator



No.	Description	No.	Description
1.	Load weight adjustment	9.	Current balance adjustment
2.	Twisted pair specimen	10.	Amp step settings
3.	Connector clamps	11.	Reset light
4.	Apparatus sample cover	12.	Elapsed time in seconds
5.	Power switch	13.	Reset button
6.	Power light	14.	Overload light
7.	Start button	15.	Safety switch
8.	Amp meter readout		

FIG. 2 Burnout Tester

proper length to fit the burnout tester, the excess shall be trimmed and each leg carefully stripped bare. Maintain a minimum of 0.5 in. (13 mm) of insulated wire between the twisted portion of the twisted pair and the stripped bare ends.

18.3 Test a minimum of five specimens for each type of film-insulated magnet wire being evaluated.

19. Procedure

19.1 **Warning**—Lethal voltages are a potential hazard during the performance of this test. It is essential that the test apparatus, and all associated equipment electrically connected to it, be properly designed and installed for safe operation. Solidly ground all electrically conductive parts which it is possible for a person to contact during the test. Provide means

for use at the completion of any test to ground any parts which were at high voltage during the test or have the potential for acquiring an induced charge during the test or retaining a charge even after disconnection of the voltage source. Thoroughly instruct all operators as to the correct procedures for performing tests safely. When making high voltage tests, particularly in compressed gas or in oil, it is possible for the energy released at breakdown to be sufficient to result in fire, explosion, or rupture of the test chamber. Design test equipment, test chambers, and test specimens so as to minimize the possibility of such occurrences and to eliminate the possibility of personal injury. If the potential for fire exists, have fire suppression equipment available. Referring to Fig. 2, use the tensiometer to adjust the load weight so that 300 ± 6.0 g of

tension will be applied to the twisted-pair specimen. Adjust the current step controls to the settings indicated in Table 3.

19.2 *Special Considerations:*

19.2.1 A warm-up is recommended prior to using the burnout tester for an actual test. This can be accomplished by replacing the twisted-pair specimen (see Section 18) with two straight lengths of AWG 18 round copper bare wire and proceed with 19.3-19.5. When the timer reaches 900 s, push reset. The tester is warmed up and ready for use.

19.2.2 If the over/under drive lamp energizes during normal testing, the results obtained are invalid. Push reset, replace the test specimen, and proceed with 19.4-19.6. This condition is often the result of poor electrical contact; cleaning the contacts may be necessary.

19.3 Secure the specimen in the burnout tester using the clamps, and close the lid. (**Warning**—Provide adequate ventilation during burnout testing of film-insulated magnet wire to remove products of decomposition.)

19.4 Turn on the main power switch and wait for completion of reset indicated by lamp.

19.5 Push the start button and after the current indicated on one meter has stabilized at first Amp setting, adjust the balance so that the second meter also reads the same.

19.6 Upon completion of the test indicated by the lamp, note the time in seconds on the meter.

19.7 Push the reset button and wait until reset is complete.

19.8 Carefully remove test specimen with needle-nose pliers and repeat 19.4-19.8 for the next specimen. (**Warning**—The twisted-pair specimen remains hot for some time after the test is completed.)

19.9 *Calculation of Overload Figure of Merit (OFM) When Using Condition #2:*

$$OFM = \Sigma(I^2t/10^5) \quad (1)$$

where:

I = the applied current in each step of the test, and

t = time in seconds for each step.

20. Report

20.1 Report the following information:

- 20.1.1 Nominal conductor size,
- 20.1.2 Build,
- 20.1.3 Type of insulation,
- 20.1.4 Test condition used (1 or 2),
- 20.1.5 Time to failure of each individual specimen,
- 20.1.6 Average time to failure, and
- 20.1.7 OFM if using Condition #2.

TABLE 3 Current Step Controls

Current Steps	Time <i>t</i> in seconds	Condition 1 No. of Twists	Condition 1 I, Amps ^A	Condition 2 No. of Twists	Condition 2 I, Amps ^A
A-1	0 to 180	16	34	8	36
A-2	181 to 360	16	36	8	38
A-3	361 to 540	16	39	8	40
A-4	541 to 720	16	43	8	42
A-5	721 to 900	16	48	8	44
A-6	901 +	8	46

^AAmps ± 2 %.

21. Precision and Bias

21.1 *Precision*—This test method has been in use for many years, but no information has been presented to ASTM upon which to base a statement of precision. No activity is planned to develop such information.

21.2 *Bias*—This test method has no bias because the value for burnout (AC overload resistance) is determined solely in terms of this test method.

CHEMICAL RESISTANCE

22. Scope

22.1 This test method determines the effects of ambient chemical conditions on film-insulated magnet wire.

23. Significance and Use

23.1 Film-insulated magnet wire may be exposed to environments that contain chemical liquids (or vapors) and retention of the integrity of the film insulation is desirable. This test provides information useful for predicting the suitability of the film-insulated magnet wire when exposed to these environments.

23.2 Since the test is normally conducted at room temperature, the results may not be indicative of performance at other temperatures.

24. Apparatus

24.1 *Containers for Liquids*—Test tubes 10 in. (250 mm) in length by 1 in. (25 mm) in diameter or equivalent.

24.2 *Scraper*—A device that will position a steel needle or music wire (Specification A 228/A 228M) 0.016 in. (0.4 mm) in diameter in a horizontal plane and perpendicular to the axis of the wire specimen. The force applied between the needle or music wire and the anvil is adjusted by adding weights to the spindle as shown in Fig. 3.

24.3 *Cheesecloth*, Grade A, bleached, unsized cheesecloth shall be used.

24.4 *Forced-Air Oven*, (see Specification D 5423).

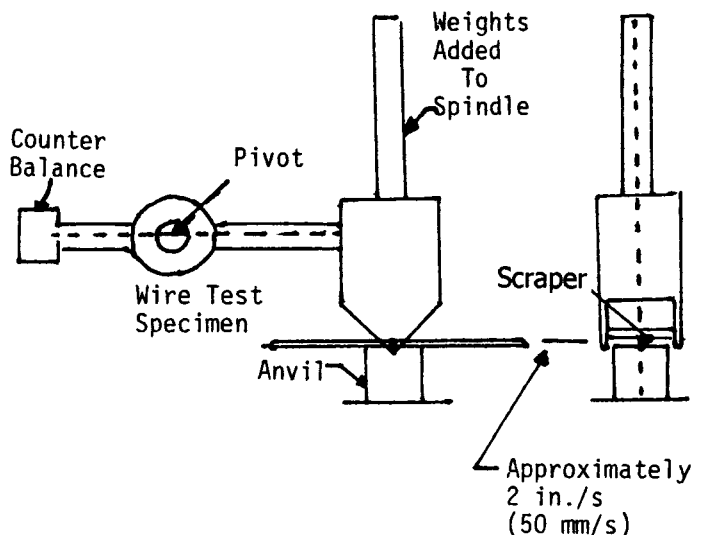

FIG. 3 Scrape Fixture for Chemical Resistance Tester

25. Test Specimen Preparation

25.1 Select 12 ± 1 in. (300 ± 25 mm) long specimens of unbent, unstretched film-insulated magnet wire. Stress anneal specimens for 10 ± 1 min at $150 \pm 3^\circ\text{C}$ ($302 \pm 5^\circ\text{F}$).

26. Procedure

26.1 *Exposure*—Immerse specimens in approximately 8 in. (200 mm) of applicable liquid at $23 \pm 2^\circ\text{C}$ ($73 \pm 4^\circ\text{F}$) for 24 h or as specified. Remove each specimen and carefully blot to dryness with a clean cheesecloth. Cut off and discard the lower 1 in. (25 mm) of the specimen.

NOTE 2—Immerse each specimen in only one liquid.

26.2 *Wire Diameter 0.10 to 0.010 in. (2.5 to 0.25 mm) (AWG 10 to 30)*—Test each specimen using the scraper device, after 1 but before 2 min after removal from the liquid. Apply the specified force to the needle and the specimen. Use 580 ± 12 g when testing 18 AWG copper wire, and 340 ± 7 g when testing 18 AWG aluminum wire. The force used to test other magnet wire sizes shall be based on agreement between user and supplier. Scrape the specimen for a length of not less than 6 in. (150 mm) of the portion previously immersed. Draw the specimen between the needle and anvil at a uniform speed of approximately 2 in./s (50 mm/s). Exposure of the conductor, as detected by visual inspection, shall constitute failure.

26.3 *Wire Diameter 0.20 to 0.114 in. (5.2 to 2.9 mm) (AWG 4 to 9) and 0.009 to 0.002 in. (0.24 to 0.05 mm) (AWG 31 to 44)*—Test each specimen after 1 but before 2 min after removal from the liquid, by drawing once, without stretching, between four folds of cheesecloth held firmly between the thumb and the forefinger. Exposure of the conductor, as detected by visual inspection, shall constitute failure.

27. Report

- 27.1 Report the following information:
 - 27.1.1 Nominal conductor size,
 - 27.1.2 Conductor composition,
 - 27.1.3 Build and type of insulation,
 - 27.1.4 Time of immersion,
 - 27.1.5 Temperature of liquid,
 - 27.1.6 Liquid used,
 - 27.1.7 Scraping force if used, and
 - 27.1.8 Visual observations, pass or fail.

28. Precision and Bias

28.1 No information is presented about either precision or bias of this test method as the determination of chemical resistance of magnet wire is nonquantitative.

DYNAMIC COEFFICIENT OF FRICTION TEST METHOD

29. Scope

29.1 This test method determines the dynamic coefficient of friction between a wire moving at constant speed and a lead contact surface.

30. Terminology

30.1 The dynamic coefficient of friction is the ratio of the force developed between a moving wire surface and the load contact surface, described by the following equation:

$$\mu_d = F/L \tag{2}$$

where:

- μ_d = dynamic coefficient of friction,
- F = force developed between a moving wire surface and the load contact surface, gf (N), and
- L = test load, gf (N).

31. Summary of Test Method

31.1 The wire specimen is pulled at a constant speed over a load contact surface under a test load (L). A frictional force (F) is developed between the wire surface and the load contact surface and transferred to an appropriate measuring device. The reading (F) is divided by the test load (L) to obtain the dynamic coefficient of friction (μ_d).

32. Significance and Use

32.1 The dynamic coefficient of friction (μ_d) of film-insulated magnet wire is primarily a measure of lubricity and the smoothness of the insulation surface. The combination of these factors represented by the coefficient of friction value affects windability, lay of wire, fill factor of electrical coils, and the spooling quality during manufacture of film-insulated magnet wire.

33. Apparatus

33.1 The tester shown in Fig. 4 is an example of an acceptable design.

33.2 A motor shall pull the wire specimen at 50 ± 5 ft/min (15 ± 1.5 m/min) across a smooth surface using a motor-driven take-up.

33.3 Various load weights shall be available, which will provide 100 to 1000 gf (0.98 to 9.81 N). The load surface shall be synthetic sapphire and have a surface roughness of not more than $0.5 \mu\text{m}$ ($20 \mu\text{in.}$). The sapphires are described and shall be mounted in accordance with Fig. 6.

33.4 There shall be a means to guide the wire and a means to maintain a slight tension, if needed.

33.5 Electronic force-measuring devices or transducers incorporated with a chart recorder measure the force due to

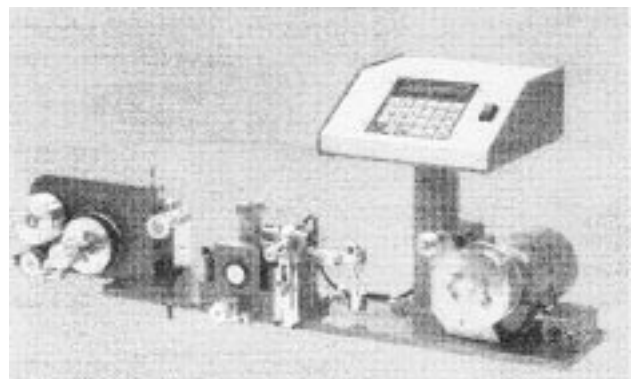
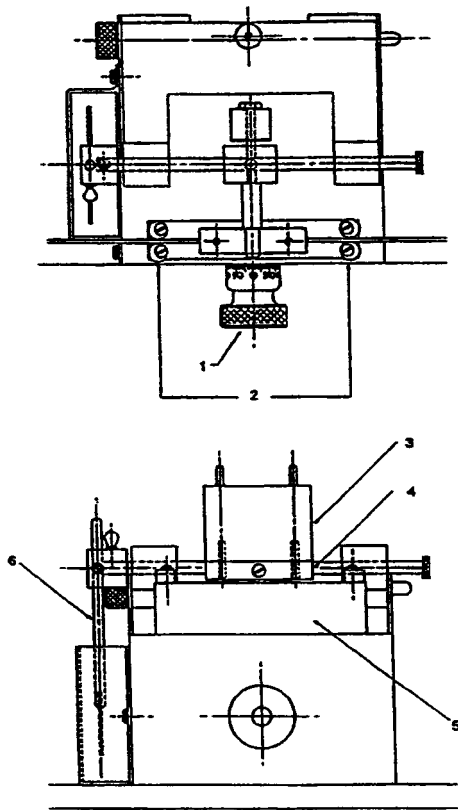

FIG. 4 Coefficient of Friction Tester



- NOTE 1—Calibrated Adjustment for parallelism between the test load and test bed surfaces.
- NOTE 2—Test Bed Guides
- NOTE 3—Test Weight
- NOTE 4—Load Block — See Figures 2-4 and 2-5
- NOTE 5—Test Bed
- NOTE 6—Dampening System

FIG. 5 Detail Drawing of Friction Head Assembly

friction. The electronic force-measuring device provides a record indicating the peak variation along the surface of the wire. A force transducer with a range of 0 to 500 gf (0 to 5.0 N) and a chart recorder with a 0 to 5 V range and a 0.5-s full-scale response time is satisfactory.

33.6 A mechanical dynamometer can be used in place of an electronic force transducer and chart recorder. Two dynamometer ranges, 0 to 50 gf (0 to 0.5 N) and 0 to 200 gf (0 to 2.0 N), are satisfactory.

33.7 Another part of the measuring device is a mechanical dampening system consisting of a paddle and a container filled to a depth of 2 ± 0.2 in. (5 ± 1 mm) with oil having a viscosity of $10\,000 \pm 500$ cps (10 ± 0.5 Pa·s) at 25°C . Dampening can also be accomplished by electronic means eliminating the need for this mechanical dampening system.

33.8 A cleaning solvent appropriate for the lubricant being tested shall be used.

34. Test Specimen

34.1 Remove the wire test specimen from the shipping package by dereeling over the end flange or pulling from the pail or drum. Remove all contaminated wire before selecting test specimens.

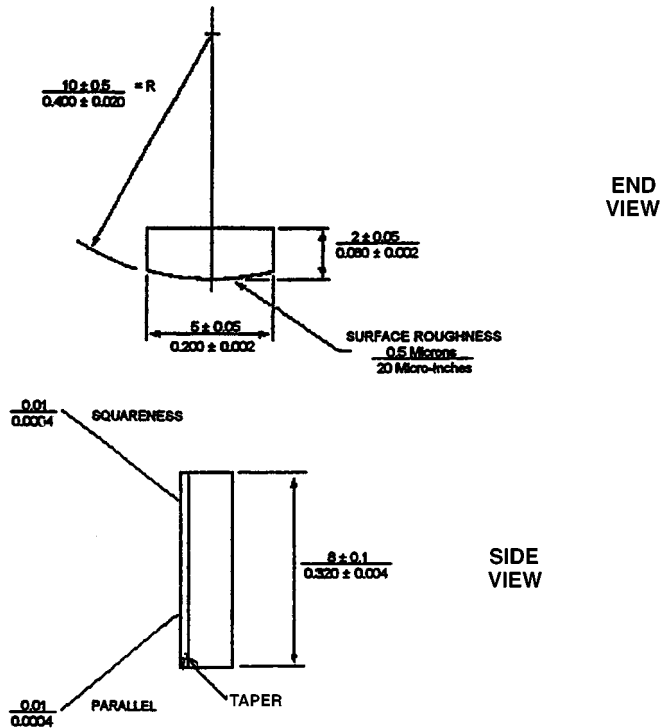

NOTE 1—Top number denotes millimetres; lower number denotes decimals of an inch.

FIG. 6 Load Contact Surface - Sapphire (Synthetic)

35. Procedure

35.1 Level off a smooth surface using the leveling leg screws and the float level. Adjust the sensitivity of the electronic force transducer to the appropriate range, and set the chart recorder at full-scale for the wire size being tested using a calibrating weight. Remove the calibrating weight after the transducer and chart recorder have been adjusted.

35.2 If a mechanical dynamometer is used, install one having the correct range for the size wire being tested according to Table 4.

35.3 Clean the sapphire surfaces located on the load block, that are in contact with the wire, with an appropriate cleaning solvent and dry thoroughly.

35.3.1 Although the wear resistance of the sapphire contact blocks exceeds that of steel, inspect the surfaces of the blocks at periodic intervals (for example, every three months) under $100\times$ magnification for evidence of wear.

35.4 Lower the dampening paddle into the oil: immerse completely for AWG 14-30; immerse one-half paddle for AWG 31-44.

35.5 Thread the wire over appropriate guide pulleys so the wire is in contact with the two sapphires.

35.6 Apply the appropriate test load according to Table 5.

TABLE 4 Dynamometer Parameters

Wire Size Range (AWG)	Grams - Force	Newtons
14-35	0-200	0 to 2.0
36-44	0-50	0 to 0.5

TABLE 5 Test Loads for Coefficient of Friction Testing

Wire Size Range (AWG)	Test Load in Grams-Force \pm 2 %	Test Load in Newtons
14–24	1000	9.9
25–35	600	5.9
36–40	200	2.0
41–44	100	1.0

TABLE 6 Threshold Fault Current

DC Test Voltage, V \pm 5 %	Threshold Fault Current \pm 10 %, μ A
3000	16
2500	14
2000	12
1500	10
1000	8
750	7
500	6
350	5

35.7 Position the test load on the test bed where no reading is indicated on the force transducer or dynamometer.

35.8 Zero the mechanical dynamometer if used. Adjust the calibrated dial to make the test load parallel with the test bed surface.

35.9 Turn on the tester to pull the test wire through the apparatus.

35.10 Apply slight tension to keep the wire traveling smoothly.

35.11 Allow time (15 s) for start-up variations to cease. Record the average dynamometer reading to the nearest grams force (newton).

36. Calculation

36.1 Calculate the average dynamic coefficient of friction (μ_d) as follows:

$$\mu_d = F/L \quad (3)$$

where:

F = average dynamometer force reading, gf (N), and

L = test load, gf (N).

37. Report

37.1 Report the following information:

37.1.1 Nominal conductor size,

37.1.2 Build,

37.1.3 Insulation type,

37.1.4 Lubricant,

37.1.5 Test load used,

37.1.6 Average coefficient of friction value (μ_d),

37.1.7 Maximum reading, and

37.1.8 Standard deviation of the readings.

38. Precision and Bias

38.1 This test method has been in use for many years, but no information has been presented to ASTM upon which to base a statement of precision. No activity is planned to develop such information.

38.2 This test method has no bias because the values for dynamic coefficient of friction are determined solely in terms of this test method.

CONTINUITY, DC HIGH VOLTAGE

39. Scope

39.1 This test method covers the evaluation of the continuity of film-insulated magnet wire, in sizes ranging from 0.0641 to 0.0020 in. (1.628 to 0.051 mm) (AWG No. 14 to 44), inclusive by dc high voltage.

40. Terminology

40.1 *Definitions of Terms Specific to This Standard:*

40.1.1 *continuity (of magnet-wire insulation), n*—the degree of freedom from defects in the film coating as indicated by the number of electrical faults per unit length.

40.1.2 *fault (in magnet-wire insulation), n*—a defect, or group of defects, within a length of wire being exposed to a proof voltage, such that current through the defect(s) will cause the test equipment to indicate one fault.

40.1.3 *fault detection current, n*—the current required to indicate a fault under specified conditions.

40.1.4 *sensitivity (of fault detector circuit), n*—the minimum current required to indicate a fault.

40.1.5 *test voltage, n*—the open-circuit voltage applied between the contact sheave and the grounded conductor.

41. Significance and Use

41.1 This test provides a method of nondestructive testing for continuity of film-insulated magnet wire. Excessive faults in film insulation could result in failure of wound coils.

42. Apparatus

42.1 **Warning**—*Lethal voltages are a potential hazard during the performance of this test. It is essential that the test apparatus, and all associated equipment electrically connected to it, be properly designed and installed for safe operation. Solidly ground all electrically conductive parts which it is possible for a person to contact during the test. Provide means for use at the completion of any test to ground any parts which were at high voltage during the test or have the potential for acquiring an induced charge during the test or retaining a charge even after disconnection of the voltage source. Thoroughly instruct all operators as to the correct procedures for performing tests safely. When making high voltage tests, particularly in compressed gas or in oil, it is possible for the energy released at breakdown to be sufficient to result in fire, explosion, or rupture of the test chamber. Design test equipment, test chambers, and test specimens so as to minimize the possibility of such occurrences and to eliminate the possibility of personal injury. If the potential for fire exists, have fire suppression equipment available.*

High Voltage Power Supply—The high voltage power supply must be regulated and provide to the electrode sheaves a filtered direct current voltage free of transient over-voltage spikes. Measure the voltage with a high impedance device, such as an electrostatic voltmeter. Provide sufficient series resistance so that rapid collapse of the voltage across the wire occurs when a fault is detected. Rapid recovery of the voltage to the test level is also required.

42.2 *Steady-State Short-Circuit Current*—The steady-state short-circuit current shall be limited by the power supply to 25

± 5 mA at any test voltage setting. A 50 M Ω fault resistance at the electrode sheaves shall not cause more than a 75 % drop in voltage on the high-voltage electrode sheaves at any voltage setting.

42.3 Fault Detection Circuit—The sensitivity of the fault detection circuit shall be such that the threshold fault current will be as shown in Table 4, with a tolerance of ± 10 %. The speed of response of the fault circuit shall be 4 to 6 ms. The fault circuit shall be designed to repeat at the rate of 450 ± 45 counts/min when bare wire is passed over the electrode sheaves.

42.4 Fault Counter—The fault counter shall be a digital readout device such as an electromechanical counter or its electronic equivalent. Means of resetting the counter to zero shall be included. Additional recorder equipment for making records of fault patterns is optional.

42.5 Electrode Sheaves:

42.5.1 For sizes AWG 14–24 (see 42.8), dual high-voltage electrode sheaves shall be constructed of stainless steel with an outside diameter of 1.69 in. (43 mm), with a “V” groove such that the included angle will be $90 \pm 3^\circ$ and the root diameter will be $1.50 +0, -0.011$ in. ($38 +0, -0.25$ mm). The electrode sheave center shall be separated by 1.81 ± 0.005 in. (46 ± 0.13 mm).

42.5.2 The electrode sheaves shall have a contact length of $1.0 +0, -0.1$ in. ($25.4 +0, -2.5$ mm). The electrode sheaves are placed between two grounded guide sheaves and on a line offset $42 \pm 3^\circ$ from a line intersecting the center of the guide sheaves. The two grounded guide sheaves are of the same material and their centers are spaced 5.50 in. (140 mm) apart on a horizontal line. These grounded sheaves are constructed with an outside diameter of 2 in. (51 mm), with a “V” groove such that the included angle will be $45 \pm 3^\circ$ and the root diameter will be 1.50 ± 0.1 in. (38 ± 2.5 mm). (See Fig. 7.)

42.5.3 For sizes AWG 31 to 44, (see 42.8) install the 1-in. diameter dual electrode sheaves. These electrode sheaves are made of stainless steel with an outside diameter of 1.13 ± 0.01 in. (28.7 ± 0.25 mm) and a “V” shaped groove such that the included angle will be $90 \pm 3^\circ$ and the root diameter will be $1.00 +0, -0.01$ in. ($25.4 +0, -0.25$ mm). The centers of the dual electrode sheaves are separated by 1.25 ± 0.005 in. (32 ± 0.13 mm). The dual electrode sheaves are adjusted to an angle resulting in $1.0 +0, -0.1$ in. ($25.4 +0, -2.5$ mm) length of wire making contact with each electrode sheave. (See Fig. 8.)

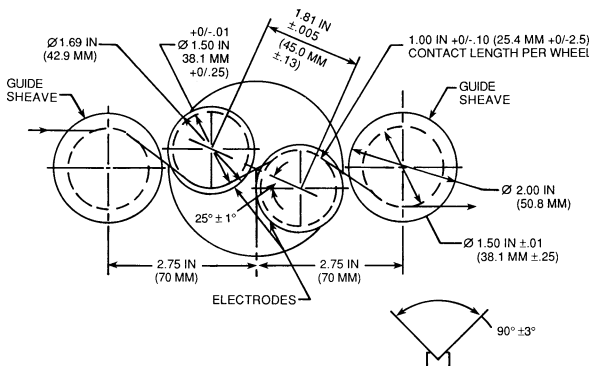

FIG. 7 Direct-Current High Voltage Continuity Electrodes for Wire Sizes 14 to 30 AWG 0.0641 to 0.010 in. (1.628 to 0.254 mm)

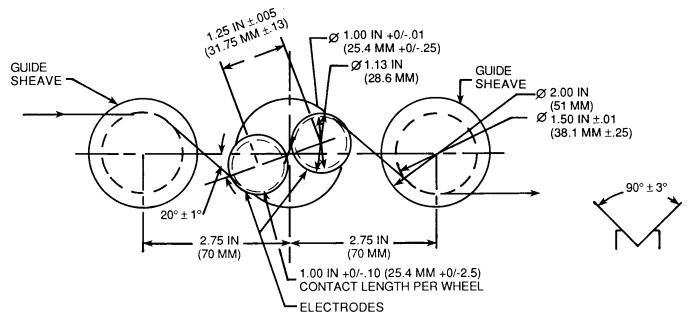

FIG. 8 Direct-Current High Voltage Continuity Electrodes for Wire Sizes 25 to 44 AWG 0.0179 to 0.0020 in. (0.455 to 0.051 mm)

42.5.4 For sizes AWG 25 to 30, either pair of high voltage dual electrode sheaves described above can be used.

42.6 Ground Insulation for Electrode Sheaves—The ground insulation for the electrode sheaves must be a high-resistivity material, nonhygroscopic and easily cleaned, and dimensioned so as to support a minimum of 3000 V direct current indefinitely. All edges of the electrode sheaves must be rounded to minimize corona.

42.7 Damping Resistor—A 0.25-W surge damping resistor of 4.7 M $\Omega \pm 10$ % must be installed in the high voltage line at the electrode sheaves connection. No shielding is used on the high voltage lead since a minimum capacitance to ground is sought during switching and counting events.

42.8 Wire Handling Equipment¹⁴—The test device includes such wire handling equipment as will provide the wire speed stipulated and is capable of handling wire sizes 14 through 44 AWG. A length indicator with a preset shutoff feature is included so that exact lengths can be monitored. The drive motor must be of the brushless type and have sufficient power to maintain a speed of 60 ± 3 ft (18 ± 1 m)/min under the heaviest load.

42.9 Forced-Air Oven, see Specification D 5423.

43. Test Specimen

43.1 Ensure by visual inspection that the 100-ft (30-m) specimen of film-insulated magnet wire is undamaged and free from contamination.

44. Procedure

44.1 Thread the specimen through the equipment as depicted in Figs. 7 and 8. Connect the conductor to the grounded terminal or to a grounded take-up drum. Payoff equipment must be designed to prevent damage to the wire under test. Maintain the open circuit test voltage between the energized (positive polarity) electrode sheaves and the grounded conductor as indicated in Table 7.

44.2 Should a referee test be required, dry a new wire specimen at $60 \pm 3^\circ\text{C}$ ($140 \pm 5^\circ\text{F}$) for 20 ± 5 min in a forced air oven, cool to room temperature, and test in accordance with the foregoing procedure.

45. Report

45.1 Report the following information:

- 45.1.1 Nominal size of conductor,
- 45.1.2 Type of conductor,

TABLE 7 DC Volts \pm 5 %

AWG Size	Single	Heavy or Grade 1	Triple or Grade 2	Quadruple
Copper				
14 to 24	1000	1500	2000	2500
25 to 30	750	1000	1500	2000
31 to 35	500	750	1000	...
36 to 44	350	500	750	...
Aluminum				
14–24	750	1500
25–28	500	1000

- 45.1.3 Build,
- 45.1.4 Insulation type,
- 45.1.5 Test voltage used, and
- 45.1.6 Number of faults per 100 ft (30 m).

46. Precision and Bias

46.1 This test method has been in use for many years, but no information has been presented to ASTM upon which to base a statement of precision. No activity is planned to develop such information.

46.2 This test method has no bias because the value for high dc voltage continuity is determined solely in terms of this method.

CONTINUITY, DC LOW VOLTAGE

47. Scope

47.1 This test method covers the evaluation of the continuity of insulation of film-insulated magnet wire 0.00176 in. (0.0447 mm) (AWG 45) and smaller in diameter, as detected by a dc voltage.

48. Terminology

48.1 *Definitions of Terms Specific to This Standard:*

48.1.1 *continuity (of magnet wire insulation), n*—the degree of freedom from defects in the film coating as indicated by the number of electrical faults per unit length.

49. Significance and Use

49.1 This test method provides a low voltage test for continuity of film-insulated magnet wire. Faults in the film insulation could result in failure of wound coils.

50. Apparatus

50.1 *Electrode Bath*—The bath shall be 1.0 ± 0.06 in. (25 ± 2 mm) long so that no point on the wire will remain in the bath for more than 0.09 s. The electrode material may be mercury, salt water solution, or other conductive material as agreed upon between user and supplier.

50.2 *Counting Circuit*, capable of recording 10 ± 1 count/s and adjustable so that a specified minimum resistance will cause the counter to operate but not allow it to operate above a specified higher resistance. These values are generally referred to as lower and upper threshold limits. These values and the test voltages are determined by mutual agreement between the manufacturer and the user.

NOTE 3—Commercially used threshold resistance values are 5000 and 10 000 Ω , with bright mercury at 20 Vdc.

51. Test Specimen

51.1 Discard sufficient wire from the spool to ensure an undamaged specimen. With specimens of high-conductivity metal (copper, silver, aluminum), 100 ft (30 m) shall be tested. For wires of high-resistance metals where the resistance of the specimen might affect the test results, multiple shorter specimens may be used and the results calculated on the basis of the shorter specimen totaling 100 ft.

52. Procedure

52.1 **Warning**—*Mercury metal vapor poisoning has long been recognized as a hazard in industry. The maximum exposure limits are set by the American Conference of Governmental Industrial Hygienists.¹⁶ The concentration of mercury vapor over spills from broken thermometers, barometers, or other instruments using mercury can easily exceed these exposure limits. Mercury, being a liquid and quite heavy, will disintegrate into small droplets and seep into cracks and crevices in the floor. The use of a commercially available emergency spill kit is recommended whenever a spill occurs. The increased area of exposure adds significantly to the mercury vapor concentration in air. Mercury vapor concentration is easily monitored using commercially available sniffers. Spot checks should be made periodically around operations where mercury is exposed to the atmosphere. Thorough checks should be made after spills.* Determine continuity by passing the insulated conductor through the electrode bath.

52.2 Apply the test voltage of 20 Vdc between the conductor and the conducting bath. The fault circuitry shall be limited to 20 mA. When testing wire for faults, the resistance of the wire accumulated on the take-up spool shall not exceed 50 % of the lower value of the specified resistance range. Pass 100 ft (30 m) of insulated wire through the conducting bath, (without elongating the wire) at a speed of 100 ft/min (30 m/min) \pm 10 %.

52.3 Calibrate the counting circuit for the specific range of resistance with the conducting bath in the circuit and the conductor at ground potential.

53. Report

- 53.1 Report the following information:
 - 53.1.1 Nominal conductor size,
 - 53.1.2 Conductor type,
 - 53.1.3 Insulation type,
 - 53.1.4 Build,
 - 53.1.5 Electrode material used in bath,
 - 53.1.6 Voltage, and
 - 53.1.7 Number of faults per 100 ft (30 m).

54. Precision and Bias

54.1 This test method has been in use for many years, but no information has been presented to ASTM upon which to base a statement of precision. No activity is planned to develop such information.

¹⁶ Available from the American Conference of Governmental Industrial Hygienists, Building D-7, 6500 Glenway Ave., Cincinnati, OH 45211.

54.2 This test method has no bias because the value for low dc voltage continuity is determined solely in terms of this test method.

COMPLETENESS OF CURE OF POLYVINYL ACETAL FILM-INSULATED MAGNET WIRE

55. Scope

55.1 This test method determines the completeness of cure of only round, rectangular or square polyvinyl acetal film-insulated magnet wire.

56. Significance and Use

56.1 Resistance to solvent is an indirect measure of the degree of cure of polyvinyl acetal-type wire insulation.

57. Reagents and Materials

57.1 *Flask*, fitted with a reflux condenser and a suitable means of heating the flask.

57.2 *Solvents*—Commercial grade toluene or purer, and denatured ethyl alcohol.

57.3 *Timer*, reading in minutes.

58. Test Specimen

58.1 The test specimens consist of straight lengths of film-insulated magnet wire of such length that one end protrudes from one of the openings in the flask and the other end is immersed 4 to 5 in. (100 to 130 mm) in the liquid. (**Warning**—To prevent the escape of vapors from the top of the condenser, do not use excessive heat.)

59. Procedure

59.1 **Warning:** Regulatory agencies have established permissible exposure limits for toluene and ethyl alcohol. Primary routes for exposure are through absorption and inhalation. Consult the Material Safety Data Sheets (MSDS) for proper handling, use, and disposal of these products.

59.2 Fill the flask 50 to 60 % full with a mixture of 30 parts toluene and 70 parts denatured ethyl alcohol by volume. Heat to a gentle boil.

59.3 Cut two pieces of film-insulated magnet wire of the proper length and stress relieve by heating for 10 ± 1 min at $125 \pm 5^\circ\text{C}$ ($257 \pm 9^\circ\text{F}$).

59.4 Immerse 4 to 5 in. (100 to 130 mm) of the wire in the boiling liquid through the reflux condenser for 5 ± 0.5 min.

59.5 At the end of the test period, remove the wire samples and examine the immersed end for wrinkling or loss of adhesion of the film. Wrinkling or loss of adhesion exceeding 0.5 in. (13 mm) from the immersed end constitutes failure. Examine sizes 0.4600 in. (11.68 mm) (AWG 4) to 0.0113 in. (0.2870 mm) (AWG 29), inclusive, with normal vision. Examine sizes 0.0100 in. (0.2540 mm) (AWG 30) to 0.0020 in. (0.0508 mm) (AWG 44), inclusive, by $6\times$ to $10\times$ magnification.

NOTE 4—Since the composition of the solvent mixture will gradually change and water may be drawn in from air when solvent is cooled, the solvents should be replaced daily.

60. Report

60.1 Report the following information:

60.1.1 Nominal conductor size,

60.1.2 Insulation type,

60.1.3 Build, and

60.1.4 Pass or fail.

61. Precision and Bias

61.1 No information is presented about either precision or bias of this test method as the determination of completeness of cure of polyvinyl acetal magnet wire magnet wire by this method is nonquantitative.

CUT-THROUGH (THERMOPLASTIC FLOW) TEMPERATURE OF ROUND FILM-INSULATED MAGNET WIRE

62. Scope

62.1 This test method determines the cut-through temperature of round film-insulated magnet wire.

63. Terminology

63.1 *Definitions of Terms Specific to This Standard:*

63.1.1 *cut-through temperature (of magnet wire), n*—the temperature at which the insulating film on the specimen deforms sufficiently to allow electrical contact between two conductors.

64. Significance and Use

64.1 This test method determines the thermoplastic flow or deformation of the film insulation which is important in application.

65. Apparatus

65.1 *Testing Device*—A device capable of exerting a constant load perpendicular to and directly over the right angle crossover of the specimen.

65.2 *Temperature Control*—Thermocouple pyrometer with 0 to 500°C temperature scale in 2°C increments.

65.3 *Testing Chamber*—Use a test chamber that can maintain a temperature rise at the test specimen of $5 \pm 1^\circ\text{C}$ ($9 \pm 2^\circ\text{F}$)/min over the required temperature range.

65.4 *Failure Detector*—The failure detector shall react to a fault current in excess of 0.1 A at 115 V, 50 or 60 Hz, between the crossed wires.

NOTE 5—Vibration of the testing device results in lowered cut-through values and is to be minimized.

66. Test Specimen

66.1 The test specimen shall consist of two appropriate lengths of round film-insulated magnet wires.

66.2 *For 14-30 AWG Wire*, test a minimum of five specimens for each film-insulated magnet wire being evaluated.

66.3 *For 30 AWG and Finer Wires*, test a minimum of nine specimens for each film-insulated magnet wire being evaluated.

67. Procedure

67.1 *Temperature Calibration*—To compensate for temperature gradients within the test apparatus, determine the

actual specimen temperature at each position throughout the expected test range with a thermocouple-pyrometer calibrated in accordance with Test Method E 220 and compare to the control or indicated temperature. Make the appropriate correction to obtain the cut-through temperature.

67.2 Position the specimen in the test device and connect to the fault detector.

67.3 Load the wire specimens with the recommended grams-force as specified in Table 8.

67.4 Increase the test chamber temperature rapidly to at least 50°C below the expected thermoplastic flow temperature. After this start temperature is reached, increase the temperature at the rate of $5 \pm 1^\circ\text{C}$ ($9 \pm 2^\circ\text{F}$)/min until failure occurs. If failure occurs within 50°C of the start temperature, test another set of specimens using a lower start temperature.

67.5 Correct the indicated thermoplastic flow temperature in accordance with 67.1.

67.6 Determine the medium of the data set for each magnet wire being evaluated.

68. Report

68.1 Report the following information:

- 68.1.1 Nominal conductor size,
- 68.1.2 Conductor type,
- 68.1.3 Insulation type,
- 68.1.4 Build,
- 68.1.5 Test load used,
- 68.1.6 Start temperature,
- 68.1.7 Temperature ramp rate, and
- 68.1.8 Median thermoplastic flow temperature.

69. Precision and Bias

69.1 This test method has been in use for many years, but no information has been presented to ASTM upon which to base a statement of precision. No activity is planned to develop such information.

69.2 This test method has no bias because the value for thermoplastic flow is determined solely in terms of this test method.

DIELECTRIC BREAKDOWN AC VOLTAGE

70. Scope

70.1 This test method determines the dielectric breakdown ac voltage, in air, of insulating media on round, rectangular or square film-insulated magnet wires at commercial power frequencies. Included are: “twist” test for round film-insulated magnet wire sizes AWG 10 to 44 inclusive, and a wrapped foil

test for round film-insulated magnet wire larger than AWG 10 and for rectangular or square film-insulated magnet wire.

NOTE 6—See Test Method D 149 for a more complete discussion of the scope, significance, and use of the voltage breakdown test.

71. Apparatus

71.1 *Transformer, Circuit Breaker, Voltage Control, and Voltmeter*—The transformer, circuit breaker, voltage control, and voltmeter shall conform to the requirements of Test Method D 149.

71.2 *Electrodes*—The electrodes shall be formed from ¼ in. (6-mm) wide foil of suitable materials such as 0.001-in. (0.025-mm) thick aluminum foil mounted in the center of a ½ in. (13-mm) wide pressure-sensitive tape or ¼ in. (6-mm) wide metal foil tape coated on one side with a conductive pressure-sensitive adhesive.

71.3 *Weights and Mandrels*, as shown in Table 9.

71.4 *Equipment for Preparing Twisted Pair Samples*, see Fig. 1.

71.5 *Thermometer*, 0 to 100°C with 1°C graduations.

71.6 *Relative Humidity Measuring Device*, capable of measuring 10 to 100 %.

71.7 *Forced-Air Oven*, (Specification D 5423) capable of maintaining $60 \pm 3^\circ\text{C}$ for 15 to 30 min.

72. Test Specimen

72.1 *Twist Test (Round Wire, 10 AWG and Finer)*—Twist two pieces of wire together for a distance of 4.75 ± 0.25 in. (120 ± 6 mm) using a suitable mechanism (see Fig. 1). The tensile load on the wires while being twisted and the number of twists are shown in Table 9. Carefully form to provide sufficient separation to prevent arc-over between end cuts.

72.2 *Wrapped-Foil Test (Round wire larger than 10 AWG, Rectangular or Square Wires)*—Electrodes (71.2) are prepared by applying a ¼ in. (6-mm) wide thin metal foil to the center of a ½ in. (13-mm) wide pressure sensitive tape. Cut the tape into strips each about 3 in. (75 mm) long. Apply four of these electrodes at right angles to the specimen at intervals of approximately 2 in. (50 mm) and wrap smoothly and firmly around the specimen a minimum of one and one-half complete turns, with the metal surface of the foil in contact with the insulation.

73. Conditioning

73.1 Determine the dielectric-breakdown voltage at ambient atmospheric conditions. Should referee tests be required, dry the prepared specimens at $60 \pm 3^\circ\text{C}$ ($140 \pm 5^\circ\text{F}$) for 20 ± 5 min in a forced-air oven; cool to room temperature and test.

74. Procedure

74.1 (**Warning**)—*Lethal voltages are a potential hazard during the performance of this test. It is essential that the test apparatus, and all associated equipment electrically connected to it, be properly designed and installed for safe operation. Solidly ground all electrically conductive parts which it is possible for a person to contact during the test. Provide means for use at the completion of any test to ground any parts which were at high voltage during the test or have the potential for*

TABLE 8 Test Loads for Thermoplastic Flow Testing

Wire Size Range (AWG)	Test Load in Grams-Force ($\pm 2\%$)
14 to 18	2000
19 to 24	1000
25 to 26	600
27 to 29	300
30 to 36	250
37 to 40	150
41 to 44	100

TABLE 9 Weights and Mandrels for Dielectric Breakdown Voltage Test

Nominal Bare Wire Size Diameter			Winding Weight on Pair ^A		Twist, ϕ^B	Maximum Winding Tension		Mandrel Diameter ^A	
in.	mm	AWG ^C	lb	Gms		lb	g	in.	mm
0.1019–0.0907	2.59–2.30	10–11	24	10800	3	12	5400	1.0	25.4
0.0808–0.0641	1.05–1.63	12–14	12	5400	4	6	2700	0.75	20.0
0.0571–0.0453	1.45–1.15	15–17	6	2700	6	3	1350	0.75	20.0
0.0403–0.0320	1.02–0.81	18–20	3	1350	8	1.5	700	0.75	20.0
0.0285–0.0226	0.72–0.75	21–23	1.5	700	12	^D	350	0.5	12.5
0.0201–0.0159	0.51–0.40	24–26	^D	340	16	^D	170	0.25	6.0
0.0142–0.0113	0.36–0.29	27–29	^D	170	20	^D	85	0.25	6.0
0.0100–0.0080	0.25–0.20	30–32	^D	85	25	^D	40	0.25	6.0
0.0071–0.0056	0.18–0.14	33–35	^D	40	31	^D	20	0.25	6.0
0.0050–0.0040	0.13–0.10	36–38	^D	20	36	^D	10	0.25	6.0
0.0035–0.0028	0.09–0.07	39–41	^D	10	41	^D	5	0.25	6.0
0.0025–0.0020	0.06–0.05	42–44	^D	5	46	^D	3	0.25	6.0

^A± 2 % tolerance on weights and mandrels.

^B ϕ = number of revolutions. Twisted section length = 4.75 ± 0.25 in. (120 ± 6 mm).

^CPrepare test specimens for intermediate diameters in accordance with the requirements for the next smaller range.

^DFor weights less than 1 lb, use kilograms only.

acquiring an induced charge during the test or retaining a charge even after disconnection of the voltage source. Thoroughly instruct all operators as to the correct procedures for performing tests safely. When making high voltage tests, particularly in compressed gas or in oil, it is possible for the energy released at breakdown to be sufficient to result in fire, explosion, or rupture of the test chamber. Design test equipment, test chambers, and test specimens so as to minimize the possibility of such occurrences and to eliminate the possibility of personal injury. If the potential for fire exists, have fire suppression equipment available.) Apply a sinusoidal ac voltage of commercial power frequency between the electrodes: film-insulated magnet wires in the case of the twisted pairs and the foil electrode and film-insulated magnet wire in the case of the wrapped foil test.

74.2 Starting at zero, increase the voltage uniformly at the rate of (500 ± 50) V/s until the film insulation is punctured, at which time determine the root-mean-square voltage. If the breakdown occurs in less than 5 s, repeat the test with the rate of voltage rise decreased sufficiently so that breakdown occurs in not less than 5 s. Test one specimen at a time. Test a minimum of three specimens from each sample.

75. Report

75.1 Report the following information:

75.1.1 Nominal conductor size,

75.1.2 Build,

75.1.3 Insulation type,

75.1.4 Number of specimens tested,

75.1.5 Type of test, twist or foil test,

75.1.6 Breakdown ac voltage: record each individual reading, and average,

75.1.7 Temperature and relative humidity of the test atmosphere, and

75.1.8 Conditioning treatment, if used.

76. Precision and Bias

76.1 This test method has been in use for many years, but no information has been presented to ASTM upon which to base a statement of precision. No activity is planned to develop such information.

76.2 This test method has no bias because the value for dielectric breakdown of magnet wire is determined solely in terms of this test method.

DIELECTRIC BREAKDOWN AC VOLTAGE AFTER BENDING

77. Scope

77.1 This test method determines the dielectric breakdown voltage, in air, of film-insulated large round (<10 AWG), rectangular or square magnet wires after bending the specimen.

NOTE 7—See Test Method D 149 for a more complete discussion of the scope, significance, and use of the voltage breakdown test.

78. Apparatus

78.1 *Transformer, Circuit Breaker, Voltage Control, and Voltmeter*—The transformer, circuit breaker, voltage control, and voltmeter shall conform to the requirements of Test Method D 149.

78.2 *Tape*—The tape shall be ¼ in. (6-mm) wide metal foil coated on one side with a conductive pressure-sensitive adhesive.

78.3 *Equipment*, to bend the specimens flatwise and edge-wise on a 90° angle over a specified mandrel. (See Fig. 9 and Table 10.)

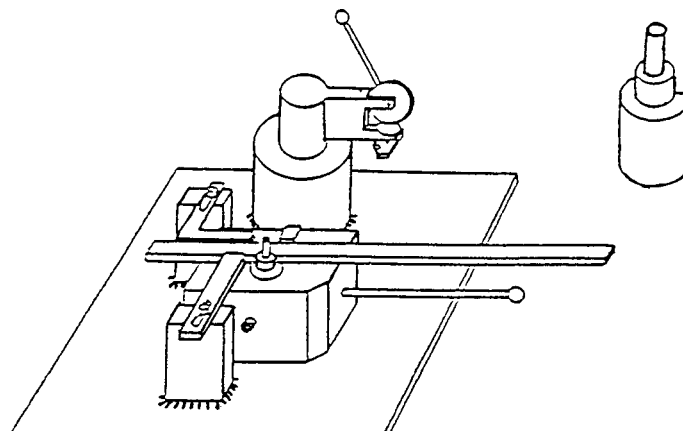

FIG. 9 Machine for Bending

TABLE 10 Mandrel Sizes

Flatwise Bend – Wire Thickness		Edgewise Bend – Wire Width		Mandrel (2 %)	
in.	mm	in.	mm	in.	mm
≤0.050	1.27 to 1.29	0.20	5.08
0.051 to 0.063	1.30 to 1.60	0.25	6.35
0.064 to 0.075	1.63 to 1.90	0.30	7.62
0.076 to 0.088	1.93 to 2.24	0.076 to 0.088	1.93 to 2.24	0.35	8.89
0.089 to 0.0100	2.26 to 2.54	0.089 to 0.100	2.26 to 2.54	0.40	10.2
0.101 to 0.125	2.57 to 3.18	0.101 to 0.125	2.57 to 3.18	0.50	12.7
0.126 to 0.150	3.20 to 3.81	0.126 to 0.150	3.20 to 3.81	0.60	15.2
0.151 to 0.187	3.84 to 4.75	0.151 to 0.187	3.84 to 4.75	0.75	19.0
0.188 to 0.219	4.78 to 5.56	0.188 to 0.219	4.78 to 5.56	0.90	22.9
0.220 to 0.250	5.59 to 6.35	0.220 to 0.250	5.59 to 6.35	1.00	25.4
0.251 to 0.310	6.38 to 7.87	0.251 to 0.310	6.38 to 7.87	1.25	31.8
...	...	0.311 to 0.375	7.90 to 9.52	1.50	38.1
...	...	0.376 to 0.435	9.55 to 11.05	1.75	44.4
...	...	0.436 to 0.500	11.07 to 12.70	2.00	50.8

78.4 *Forced-Air Oven*—See Specification D 5423.

79. Test Specimen

79.1 Elongate six undamaged 10-in. (250-mm) specimens of film-insulated shaped magnet wire 10 %. Bend each specimen approximately 4 in. (10 mm) from each end, three flatwise and three edgewise, on a 90° angle over a mandrel as specified in Table 9 in the form of a \square . During the bending operation, take caution to prevent external damage to the film insulation such as may occur due to scraping, cutting, etc. Wrap a strip of ¼ in. (6-mm) wide conductive adhesive metal foil tape around the wire smoothly and firmly a minimum of one and one-half complete turns at the center of each bend.

79.2 Following the bending procedure and prior to applying the tape, examine the specimen with normal vision for cracks in the film insulation which expose the conductor. If such cracks appear they are to be noted and a new specimen is to be prepared.

80. Conditioning

80.1 Determine the dielectric breakdown ac voltage at ambient conditions. Should referee tests be required, dry the specimens at $60 \pm 3^\circ\text{C}$ for 20 ± 5 min, cool, and test.

81. Procedure

81.1 Apply a sinusoidal voltage of commercial power frequency between the foil electrodes and conductor in accordance with Section 73.

82. Report

- 82.1 Report the following information:
- 82.1.1 Nominal conductor size,
 - 82.1.2 Build,
 - 82.1.3 Insulation type,
 - 82.1.4 Conductor type,
 - 82.1.5 Breakdown ac voltage, each individual value, and average,
 - 82.1.6 Temperature and relative humidity of the test atmosphere,
 - 82.1.7 Conditioning treatment, if used, and
 - 82.1.8 Visual failures noted.

83. Precision and Bias

83.1 This test method has been in use for many years, but no information has been presented to ASTM upon which to base a statement of precision. No activity is planned to develop such information.

83.2 This test method has no bias because the value for dielectric breakdown of magnet wire after bending is determined solely in terms of this test method.

DIELECTRIC BREAKDOWN AC VOLTAGE AT ELEVATED TEMPERATURE

84. Scope

84.1 This test method determines the dielectric breakdown ac voltage, in air, at elevated temperature of round film-insulated magnet wire.

85. Significance and Use

85.1 Film-insulated magnet wire is subjected to elevated temperatures in air. (See Section 70.) This test is sometimes required in material specifications.

86. Apparatus

86.1 *Suitable Specimen Holder*:

86.2 *Forced-Air Oven*, (see Specification D 5423), modified to accept high temperature high voltage lead wires.

86.3 *Source of 60 Hz Voltage*, conforming to the requirements of 71.1.

86.4 *Equipment*, for preparing twisted pairs of round film-insulated magnet wire specimens (see Fig. 1).

87. Test Specimen

87.1 Five test specimens shall be prepared in accordance with 72.1.

88. Procedure

88.1 Set the oven at the required test temperature $\pm 2^\circ\text{C}$ ($\pm 4^\circ\text{F}$).

88.2 Place the specimens in a forced air oven and connect them to the high voltage cables.

88.3 Apply the test voltage 15 min after the oven has returned to test temperature.

88.4 Complete the test within 30 min after the specimens are placed in the oven.

88.5 Use the voltage rise and breakdown measurement as described in 71.1.

89. Report

89.1 Report the following information:

89.1.1 Nominal conductor size,

89.1.2 Insulation type,

89.1.3 Build,

89.1.4 Test temperature,

89.1.5 The dielectric breakdown voltage for each specimen, and

89.1.6 The average breakdown ac voltage.

90. Precision and Bias

90.1 This test method has been in use for many years, but no information has been presented to ASTM upon which to base a statement of precision. No activity is planned to develop such information.

90.2 This test method has no bias because the value for dielectric breakdown of magnet wire at elevated temperature is determined solely in terms of this test method.

DIELECTRIC BREAKDOWN AC VOLTAGE AFTER CONDITIONING IN REFRIGERANT ATMOSPHERE

91. Scope

91.1 This test method determines the dielectric breakdown ac voltage of film-insulated round magnet wire after conditioning in a refrigerant atmosphere at elevated pressures.

92. Summary of Test Method

92.1 Twisted-pair specimens are conditioning in a high-pressure refrigerant atmosphere, removed, exposed at $150 \pm 3^\circ\text{C}$ ($302 \pm 5^\circ\text{F}$), and cooled to room temperature. The dielectric breakdown voltage is then determined.

93. Significance and Use

93.1 Refrigerant at elevated temperature and pressure may affect the dielectric strength of film-insulated magnet wire.

94. Apparatus

94.1 *Equipment*, for preparing twisted-pair specimens (see Fig. 1).

94.2 *Autoclave Assembly*, as described in 134.7.

94.3 *Hot Plate*, mantle, or circulating constant-temperature water bath as described in 134.8.

94.4 *Vacuum Pump*, as described in 134.9.

94.5 *Forced-Air Oven*, capable of maintaining $150 \pm 3^\circ\text{C}$ ($302 \pm 5^\circ\text{F}$). See Specification D 5423.

94.6 *Dielectric Breakdown Test Set*, as described in 71.1.

94.7 *Platform Balance*, as described in 134.3.

94.8 *Desiccator*, capable of storing the twisted-pair specimens.

95. Reagent

95.1 *Monochlorodifluoromethane Refrigerant*, or other specified refrigerants, as selected from Table 11.

TABLE 11 Refrigerants and Applicable Pressures

Refrigerant Formulation	R-number	Critical Pressure		Test Pressure	
		Psia	MPa	Psia	MPa
CCl ₃ F	R-11	639.5	4.40	525 ± 50	3.61 ± 0.34
CCl ₂ F ₂	R-12	596.9	4.11	490 ± 50	3.37 ± 0.34
CHClF ₂	R-22	721.9	4.97	600 ± 50	4.13 ± 0.34
CCl ₂ F ₂ /CH ₃ CHF ₃	R-500	631.0	4.35	525 ± 50	3.61 ± 0.34
CHClF ₂ /CClF ₂ -CF ₃	R-502	591.0	4.07	500 ± 50	3.44 ± 0.34
CHCl ₂ CF ₃	R-123	532.0	3.67	300 ± 50	2.06 ± 0.34
CH ₂ FCF ₃	R-134a	590.5	4.06	400 ± 50	2.75 ± 0.34

96. Test Specimen

96.1 Prepare five twisted pairs of specimens in accordance with 72.1. The wire size normally used is AWG 18 (0.0403 in.) (1.02 mm), heavy build.

97. Procedure

97.1 (**Warning**—Since the test is performed under elevated temperature and pressure, it is imperative that all possible precautions must be taken to control and limit temperature. Construct the autoclave assembly in accordance with 134.7. Keep the autoclave pressure at least 60 psi (415 kPa) below the critical pressure of the refrigerant used.) Condition the specimens at $150 \pm 3^\circ\text{C}$ ($302 \pm 5^\circ\text{F}$) for 4 h.

97.2 Place the specimens in the autoclave, then assemble and seal the autoclave.

97.3 Evacuate the autoclave to 250 $\mu\text{m Hg}$ (33.33 Pa).

97.4 Charge the autoclave with 1400 ± 50 g of refrigerant.

97.5 Heat the autoclave to obtain the appropriate pressure gage reading as selected from Table 11, and maintain for 72 ± 1 h. If refrigerants other than those listed in Table 11 are used, the pressure during test should be maintained at a level of 80 to 90 % of the critical pressure of that refrigerant. (See Note 17.)

97.6 Remove the autoclave from the heat source and release the refrigerant.

97.7 When the gage pressure reaches 0 psi, carefully remove the cover and transfer the specimens within 60 s to an oven at $150 \pm 3^\circ\text{C}$ ($302 \pm 5^\circ\text{F}$).

97.8 After 10 ± 1 min, remove the specimens and place in a desiccator to cool to room temperature.

97.9 Test the specimens in accordance with Section 74.

98. Report

98.1 Report the following information:

98.1.1 Identification of the specimen,

98.1.2 Conductor type,

98.1.3 Build,

98.1.4 Insulation type,

98.1.5 Type of refrigerant,

98.1.6 Dielectric breakdown ac voltage of each specimen,

98.1.7 Pressure, and

98.1.8 Temperature.

99. Precision and Bias

99.1 This test method has been in use for many years, but no information has been presented to ASTM International upon which to base a statement of precision. No activity is planned to develop such information.

99.2 This test method has no bias because the value for dielectric breakdown of magnet wire after refrigerant conditioning is determined solely in terms of this test method.

$$A = B - C \quad (4)$$

DIMENSIONAL MEASUREMENT OF CONDUCTOR AND FILM-INSULATED MAGNET WIRE

100. Scope

100.1 This test method determines the dimensions of the conductor and film-insulated magnet wire.

101. Significance and Use

101.1 Film-insulated magnet wire and conductor dimensions are basic parameters used in the design of electrical machinery. The breakdown voltage and other properties are related to the film thickness.

102. Apparatus

102.1 *Optical Micrometers*—Calibrate the equipment according to the manufacturer's specifications.

102.2 *Calibrated Hand or Bench Micrometers*, with an anvil diameter of 0.25 in. (6 mm). Calibrate the micrometer with wire standards according to manufacturer's specifications. Refer to Test Methods D 374.

102.3 *Electrical Resistance Measurements*—Used in accordance with Test Method B 193 are an acceptable option in determining indirectly the diameter of an equivalent round cross section of a conductor smaller than 0.0020 in. (0.051 mm) (AWG 44).

NOTE 8—Other instruments such as electronic micrometers may be used for measuring.

103. Test Specimen

103.1 For all film-insulated magnet wire where micrometer measurements are used, the test specimens shall consist of 4 to 6 in. (100 to 155 mm) straight lengths of wire free from kinks or obvious defects. Carefully remove specimen from the spool or container to avoid damaging or stretching.

103.2 For conductors smaller than 0.0020 in. (0.051 mm) where resistance measurements are to be used, the test specimens shall consist of 3 ft (1.0 m) or longer lengths of wire.

104. Procedure

104.1 Round Wire:

104.1.1 *Using an Optical Device such as a Laser Micrometer (Preferred Method):*

104.1.1.1 Measure the overall diameter of the film-insulated wire at a minimum of four different positions around the circumference. Record the average of these readings as the overall diameter.

104.1.1.2 Remove the insulation at approximately the same position on the wire by means not injurious to the conductor (see 104.3), and repeat the measurements around the conductor.

104.1.1.3 Record the average of these readings as the diameter of the conductor.

104.1.1.4 Calculate the increase in diameter due to the insulation in accordance with the following equation:

where:

A = increase in diameter due to the insulation,

B = overall diameter, and

C = diameter of conductor.

104.1.2 *Using a Calibrated Hand or Bench Micrometer (Alternative Method):*

104.1.2.1 Measure the film-insulated wire at four points, spaced approximately 45° apart, around the circumference. Record the largest and smallest readings and take the average of these two readings as the overall diameter.

104.1.2.2 Remove the insulation at approximately the same position on the wire by means not injurious to the conductor (see 104.3), and repeat the measurements around the conductor.

104.1.2.3 Calculate the average of the largest and smallest readings as the diameter of the conductor.

104.1.2.4 For sizes AWG 25 and finer use a spindle force of 3 to 5 oz (0.8 to 1.4 N), and for sizes larger than AWG 25 use a spindle force of 8 to 10 oz (2.2 to 2.8 N).

104.1.2.5 Calculate the increase in diameter due to the insulation in accordance with the equation in 35.

104.1.3 *Determining Dimensions of Self-Bonding Magnet Wires:*

104.1.3.1 Measure the overall diameter according to 104.1.1.1 or 104.1.2.1.

104.1.3.2 Remove the self-bonding overcoat by immersion of the wire for approximately 2 min in a solvent that will remove the outer coating without swelling or softening the underlying film. Wipe the wire surface with a cloth or tissue dampened with the solvent to ensure complete removal of the outer self-bonding layer. Dry the wire sample.

104.1.3.3 Measure the diameter of the underlying film coated wire according to 104.1.1.1 or 104.1.2.1 and record the results as the diameter of the underlying film.

104.1.3.4 Calculate the increase in diameter due to the self bonding overcoat using the following equation:

$$\begin{aligned} & \text{(Increase in diameter due to self-bonding overcoat)} \\ & = \text{(Overall diameter)} - \text{(Diameter of underlying film coated wire)} \end{aligned} \quad (5)$$

104.1.3.5 Remove the insulation as described in 104.3.

104.1.3.6 Measure the diameter of the bare conductor diameter according to 104.1.1.1 or 104.1.2.1.

104.1.3.7 Calculate the increase in diameter due to the underlying film coating according to the following equation:

$$\begin{aligned} & \text{(Increase in diameter due to underlying film coating)} \\ & = \text{(Diameter of underlying film coated wire)} \\ & - \text{(diameter of conductor)} \end{aligned} \quad (6)$$

104.2 Rectangular or Square Wire:

104.2.1 Measure the increase in dimensions due to the insulation on three carefully straightened specimens, each at least 3 in. (75 mm) long, taken from the reel at 1 ft (300 mm) intervals. Straightening is accomplished by stretching the wire not more than 1 % to remove bends or kinks. Make one measurement of the thickness and width on each of the three specimens.

104.2.2 Calculate the average of the three thickness specimen readings as the overall thickness dimension. Determine the average of the three width measurements in the same manner. Remove the insulation at these points by means not injurious to the conductor (see 104.3.1 and 104.3.2) make the same measurements, and take the average as the dimension of the conductor. Use a pressure-type micrometer with 8 to 10 oz (2.2 to 2.8 N) of spindle force.

104.2.3 *Thickness*—Calculate the increase in the thickness due to the insulation in accordance with the following equation:

$$D = E - F \quad (7)$$

where:

- D* = increase in thickness,
- E* = overall thickness, and
- F* = thickness of conductor.

104.2.4 *Width*—Determine the increase in width in the same manner as the increase in thickness.

NOTE 9—Measure the radii of conductor by standard radius gage.

104.3 Insulation Removal Methods:

104.3.1 Remove the film coatings with a chemical stripper that is not injurious to the conductor. If removing only the self-bonding overcoat, use a solvent that will remove the bond coat but not swell or change dimensions of the underlying film.

104.3.2 Remove the film coatings from the conductor by flame followed by immediate immersion into a low-boiling alcohol such as methyl or denatured ethyl alcohol, or mixtures of these and water.

105. Report

105.1 Report the following information:

- 105.1.1 Identification of specimen,
- 105.1.2 Nominal conductor size,
- 105.1.3 Conductor type,
- 105.1.4 Conductor thickness,
- 105.1.5 Insulation type,
- 105.1.6 Build,
- 105.1.7 Average diameter of film-insulated round wire, or average width and thickness dimensions of film-insulated rectangular or square wire,
- 105.1.8 Minimum and maximum overall dimensions,
- 105.1.9 Average diameter of round conductor, or average width and thickness dimensions of rectangular or square conductor, and
- 105.1.10 Average film build to the diameter or to the width and thickness.

106. Precision and Bias ¹³

106.1 In comparing two averages of six measurements, the difference shall not exceed the critical differences in Table 12, in 95 cases out of 100 when all of the observations are taken by the same well-trained operator using the same piece of test equipment and specimens randomly drawn from the same sample of material.

TABLE 12 Critical Difference, in.^A

Name of Property	Number of Observations in Each Average	Single Operator Precision	Within Laboratory Precision	Between Laboratory Precision
Dimensions, fine wire bare conductor	4	0.000063	0.000227	0.000297
Dimensions, heavy wire bare conductor	4	0.000101	0.000337	0.000359
Dimensions, fine wire film-insulated	4	0.000076	0.000198	0.000198
Dimensions, heavy wire film-insulated	4	0.000090	0.000323	0.000343

^AThe critical differences were calculated using $t = 1.960$, which is based on infinite degrees of freedom.

106.2 *Precision*—Two averages of observed values should be considered significantly different at the 95 % probability level if the difference equals or exceeds the critical differences listed in Table 12.

106.3 *Bias*—The true value of the properties listed in Table 12 can only be defined in terms of specific test methods. Within this limitation, the procedures for determining the dimensions of bare and film-insulated magnet wire have no known bias.

DISSIPATION FACTOR MEASUREMENTS FOR MAGNET WIRE FILMS

107. Scope

107.1 This test method determines the dissipation factor of film insulation on round, rectangular or square wires, with the specimen immersed in liquid metal at room temperature or at elevated temperature.

108. Terminology

108.1 *dissipation factor (DF), n*—see Test Methods D 150.

109. Significance and Use

109.1 The dissipation factor test may be used to control the cure of most magnet wire films, once the proper cure range for each film is established through multiple property measurements. The proper cure range of a given film can be established by producing wire samples with a range of cures such that all of the physical, chemical, thermal and electrical wire properties indicate the limits of acceptable cure. The acceptable cure range is defined by those wire specimens meeting all of the important wire film properties. Choose a temperature which provides a spread in the dissipation factor that allows discernment between cures.

NOTE 10—Other cure measurement methods have been used successfully with magnet wire insulation. They include glass transition temperatures as determined by DSC (see Test Method E 1356) and TMA (see Test Method E 1545).

110. Apparatus

110.1 *Automatic RCL Bridge or Equivalent*—A bridge with a minimum of 0.1 % accuracy, based on a capacitance and a capacitance range of approximately 0.01 to 0.2 F, and 1000 Hz. Other measuring devices or frequencies may be used.

110.2 *Liquid Metal*—Mercury, to be used for room temperature DF measurements and any suitable alloy metal which will provide a liquid metal below the chosen DF temperature.

110.3 *Cell to Contain the Metal*—The pot or cell shall be of sufficient size to allow for immersion of the test specimen to the desired depth for an accurate DF measurement. A means of electrically connecting to the liquid metal shall be provided along with the necessary heating element and temperature control device to allow for accurately controlled elevated temperatures in the cell. The cell temperature sensing device shall be within 0.25 in. (6.35 mm) of the bottom of the wire sample used to measure DF. The control device shall maintain the temperature of the liquid metal to within $\pm 0.5^{\circ}\text{C}$ ($\pm 1^{\circ}\text{F}$) of the selected temperature.

110.4 *Form*, for immersing wire specimen, necessary for fine wire measurements, may be composed of metal or any dielectric material capable of withstanding the selected DF temperature.

110.5 *Forced Air Oven*—see Specification D 5423.

110.6 *Timer*—A timer capable of measuring 1.5 min to an accuracy of 1 s.

111. Test Specimen

111.1 The test specimen, free from defects and blemishes, shall be of sufficient length, when formed into a U-shape, to allow for immersion in the liquid metal to the desired depth with both legs of the U-shaped specimen above the liquid metal surface. One leg has added length for an electrical connection to the bridge.

111.2 A minimum of three samples will be run.

112. Procedure

112.1 **Warning**—*Mercury metal vapor poisoning has long been recognized as a hazard. When using equipment containing or requiring the use of mercury, take all precautions and care to avoid the escape of mercury vapor or the spillage of mercury. Maximum limits for mercury concentrations in industrial atmospheres are set by governmental agencies. These limits are usually based upon recommendations made by the American Conference of Governmental Industrial Hygienists located in Building D-7 at 8500 Glenway Drive, Cincinnati, Ohio 45211. It is possible for the concentration of mercury vapors accompanying spills from broken thermometers, barometers, and other instruments using mercury to exceed these limits. Mercury, being a heavy liquid with high surface tension, readily disperses into small droplets after spills, lodging in cracks and crevices. Resultant increased surface area of the mercury due to this dispersion promotes higher mercury concentrations in the surrounding air. Mercury vapor concentrations are readily measured using commercially available instrumentation. To monitor environmental hazards it is advisable to make periodic checks for mercury content at locations where mercury is exposed to the atmosphere. Use a spill kit for clean-up whenever spillage occurs. After spills and clean-up, make thorough checks for mercury vapor concentrations in the atmosphere.*

112.2 Select the temperature for the dissipation factor measurement and allow the liquid metal to stabilize at this temperature. As indicated under 109.1, a number of test temperatures will be required to establish the chosen temperature. Select the frequency at which the DF measurements will be made. 1000 Hz is normally used.

112.3 Wipe the wire specimen with a soft clean cloth or tissue, and carefully form it into proper U-shape. (The radius of any bend shall not be less than five times the thickness or diameter of the conductor, to prevent cracking.)

112.4 Place the U-shaped specimen in the oven at $60 \pm 3^{\circ}\text{C}$ for 20 ± 5 min to eliminate surface moisture from the film.

112.5 As soon as possible, and within 15 s after the removal of the specimen from the 60°C oven, immerse it in the liquid metal cell for DF measurement.

112.6 Take the DF reading after a 1-min immersion in the liquid metal.

113. Report

113.1 Report the following information:

- 113.1.1 Nominal conductor size,
- 113.1.2 Conductor type,
- 113.1.3 Insulation type,
- 113.1.4 Build,
- 113.1.5 Temperature,
- 113.1.6 Frequency, and
- 113.1.7 Dissipation factor (DF).

114. Precision and Bias ¹³

114.1 *Precision of Room Temperature Measurements:*

114.1.1 This precision statement is based upon an interlaboratory study in which a single operator in each of seven different laboratories conducted room temperature dissipation factor measurements on two samples of polyimide-insulated copper wires.

114.1.2 The data were analyzed and the within-laboratory and between-laboratory standard deviations were found to be as follows:

$$\begin{aligned} \text{Within laboratory} &= 0.00013 \\ \text{Between laboratory} &= 0.00122 \end{aligned}$$

114.2 *Precision of Elevated Temperature Measurements:*

114.2.1 This precision statement is based upon an interlaboratory study in which a single operator in each of four different laboratories conducted elevated temperature dissipation factor measurements on a sample of modified polyester-insulated copper wire overcoated with polyamideimide (NEMA MW35-C).

114.2.2 The data (at 250°C) were analyzed and the within-laboratory and between-laboratory standard deviations were found to be as follows:

$$\begin{aligned} \text{Within laboratory} &= 0.01269 \\ \text{Between laboratory} &= 0.03743 \end{aligned}$$

114.3 *Bias*—The true dissipation factor value can be defined only in terms of a specific test method. Within this limitation, the procedures for measuring room temperature and elevated temperature dissipation factors of magnet wire film has no known bias.

ELECTRICAL RESISTANCE OF CONDUCTORS

115. Scope

115.1 This test method determines the electrical resistance of conductors.

116. Significance and Use

116.1 Resistance measurements are necessary to meet application criteria. Resistance is influenced by conductor dimensions, composition, and temperature.

117. Apparatus

117.1 The types of apparatus used for measuring resistance are specified in Test Method B 193.

118. Test Specimen

118.1 The test specimen shall conform to the requirements in Test Method B 193.

119. Procedure

119.1 Determine the electrical resistance of the test specimen in accordance with Test Method B 193.

119.2 Prior to measuring electrical resistance, remove the film insulation on both ends of the test specimen for electrical contact. The cleaning operation shall not affect the conductor dimensions.

119.3 Prevent heating of the specimen while balancing the bridge. Such heating could result from prolonged application of current or changes in temperature due to ambient events such as air drafts.

120. Report

120.1 Report the following information:

120.1.1 Identification of specimen,

120.1.2 Nominal conductor size,

120.1.3 Conductor type,

120.1.4 Insulating type,

120.1.5 Test conditions,

120.1.6 Test length of specimen,

120.1.7 Apparatus used, and

120.1.8 Resistance reading, expressed in ohms per unit length corrected to 20°C (68°F).

121. Precision and Bias

121.1 This test method has been in use for many years, but no information has been presented to ASTM upon which to base a statement of precision. No activity is planned to develop such information.

121.2 This test method has no bias because the value for the electrical resistance of magnet wire conductors is determined solely in terms of this test method.

ELONGATION

122. Scope

122.1 This test method determines the elongation of film-insulated magnet wire at the breaking point.

123. Significance and Use

123.1 Elongation provides a general measure of the ductility of film-insulated magnet wire. Useful indications of the flexibility and adherence of film insulation to the conductor may be derived from this test.

124. Apparatus

124.1 *Elongating Equipment*—The elongating equipment shall be capable of the following: accepting a specimen of 10 ± 0.1 in. (250 ± 2.5 mm) effective length; having a constant extension rate of 12 ± 1 in./min (300 ± 25 mm/min) to the breaking point.

124.1.1 The precision of the length measurement shall be within 1 %.

124.1.2 The grips used shall be such that there will be no slipping or damage to the specimen between bench marks.

NOTE 11—See Test Methods E 8 for a discussion of machines, gripping devices, and rates of stressing. Drum or capstan-type grips have been found to be unsatisfactory.

125. Test Specimen

125.1 A test specimen consists of a 12-in. (300-mm) straight length of film-insulated magnet wire.

125.2 Test a minimum of three samples.

126. Procedure

126.1 Elongate the wire in the testing equipment at a constant rate of 12 ± 1 in./min (300 ± 25 mm/min).

126.2 Measure the distance between jaws at the break, or when bench marks are used, place the broken ends of the specimen together, and measure the actual distance between the bench marks.

126.3 Discard the results for specimens that break within 1 in. (25 mm) of the bench marks or jaws. When the breaks occur frequently in this manner, a need for modification of the equipment or technique is indicated. When the bench mark method is used, locate the bench marks centrally not more than 3 in. (75 mm) from either jaw. In order to minimize the effect of local variations in the wire under test, test three specimens of the sample.

126.3.1 Rectangular or square film-insulated magnet wires or round conductors larger than 0.0641 in. (1.628 mm) commonly are tested using bench marks.

127. Calculation

127.1 Calculate the elongation as follows:

$$\text{elongation, \%} = [(A - B)/B] \times 100 \quad (8)$$

where:

A = length at break, and

B = original effective length.

128. Report

128.1 Report the following information:

128.1.1 Nominal conductor size,

128.1.2 Conductor type,

128.1.3 Insulation type,

128.1.4 Build,

128.1.5 Original effective length, whether or not bench marks are used,

128.1.6 Rate of elongation,

128.1.7 Individual and average elongation, and

128.1.8 Visual effect of elongation on insulation.

129. Precision and Bias¹³

129.1 In comparing two averages of three observations each, the differences should not exceed the critical differences in Table 13, in 95 cases out of 100 when all of the observations are taken by the same well-trained operator using the same piece of test equipment and specimens randomly drawn from the same sample of material.

129.2 *Precision*—Two averages of observed values shall be considered significantly different at the 95 % probability level if the difference equals or exceeds the critical differences listed in Table 13.

129.3 *Bias*—The true value of the elongation of film-insulated magnet wire can only be defined in terms of a specific test method. Within this limitation, the procedures for measuring the elongation of film-insulated magnet wire have no known bias.

EXTRACTABLES OF FILM-INSULATED MAGNET WIRE BY REFRIGERANTS

130. Scope

130.1 This test method determines the percentage of insulation on film insulated magnet wire that can be extracted by refrigerants or related solvents. This test method is applicable for round film-insulated magnet wire size 0.0641 to 0.010 in. (1.628 to 0.254 mm) and with suitable specimen modifications can be used for heavier round wire, and for rectangular or square wire.

131. Terminology

131.1 *Definitions of Terms Specific to This Standard:*

131.1.1 *extractables (of magnet wire insulation), n*—that portion of the film insulation which is soluble under specified conditions.

132. Summary of Test Method

132.1 The specimen is subjected to extraction by a specified refrigerant (monochlorodifluoromethane, R-22, is commonly used). Extraction is conducted in a pressurized vessel using a siphon cup. The refrigerant is evaporated and the weight of residue is determined.

TABLE 13 Critical Differences, Percentage Points^{A,B}

Properties, Procedure, And Materials	Number of Observations in Each Average	Single Operator Precision	Within Laboratory Precision	Between Laboratory Precision
Elongation, Manual Operated Tester, Copper	3	1.31	2.27	4.25
Elongation, Manual Operated Tester, Aluminum	3	1.78	3.62	5.38
Elongation, Stress-Strain Tester, Copper	3	1.40	3.28	7.90
Elongation, Stress-Strain Tester, Aluminum	3	2.56	6.07	8.91
Elongation, Motor Driven Tester, Copper	3	1.37	2.88	5.33
Elongation, Motor Driven Tester, Aluminum	3	1.86	3.75	5.07

^AThe critical differences were calculated using $t = 1.960$, which is based on infinite degrees of freedom.

^BAll testers fall within the apparatus description in Section 124.

133. Significance and Use

133.1 The extractable material is functionally important since the extractables may be redeposited in the capillary tubes of refrigeration systems.

NOTE 12—The exact percentage value of extractables will vary with wire size and film thickness. Finer wire will yield higher levels because of greater surface areas exposed for any given quantity of film insulation.

134. Apparatus

134.1 *Forced-Air Oven*, see Specification D 5423.

134.2 *Analytical Balance*, accurate to ± 0.1 mg.

134.3 *Platform Balance*, with a capacity of 50 ± 0.1 lbs (22.7 ± 0.045 kg).

134.4 *Aluminum Weighing Dishes*, 78 mm in diameter and 28 mm high.

134.5 *Desiccator*, with efficient desiccant, capable of storing beakers, aluminum dishes, and specimens.

134.6 *Siphon Extraction Cup* (Fig. 10) a 450 mL SS modified Wiley cup.¹⁷

134.7 *Autoclave Assembly*,¹⁸ consisting of a 2-L stainless steel cylinder with a removable cover containing a 0 to 1000-psi (0 to 6.89-MPa) pressure gage, a valve for admitting and releasing gas, a rupture disk set at 1000 psi (6.89 MPa), and a refluxing coil with inlet and outlet water connections. The assembled and sealed pressure vessel shall include an

¹⁷ Extraction Cup No. AG-52HC, available from Parr Instrument Co., has been found suitable for this purpose.

¹⁸ Autoclave Assembly No. 4632, available from Parr Instrument Co., has been found suitable for this purpose.

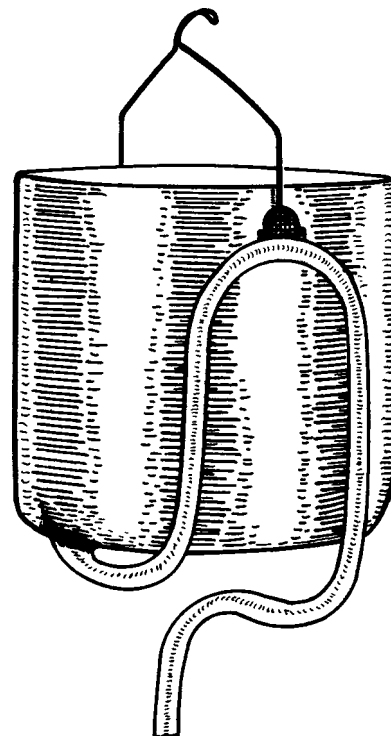

FIG. 10 Siphon Cup (see Appendix X1)

overpressure switch to disconnect the power and shall be capable of withstanding 3000 psi (20.68 MPa) with the rupture disk inoperative.

134.8 *Hot Plate*, rated at 2000-W with a variable voltage supply, connected to the overpressure cutoff switch. A mantle may be substituted provided adequate controls are present.

134.9 *Vacuum Pump*, capable of evacuating the autoclave and maintaining a vacuum of approximately 250 $\mu\text{m Hg}$ (33.33 Pa).

134.10 *Cold Water Supply for the Condenser*, capable of maintaining a fairly constant temperature for 6 h.

135. Reagents

135.1 *Chemical Stripper*, capable of removing the insulating film completely without attacking the conductor.

135.2 *Chloroform*, ACS grade, or distilled methylene chloride.

135.3 *Monochlorodifluoromethane Refrigerant (Distilled)*, or other refrigerant as specified (Table 11).

135.4 Distilled petroleum ether or suitable wash solvent that does not leave a residue following evaporation. (**Warning**—Since the test is performed at elevated temperature and pressure, it is imperative that all precautions must be taken to control and limit temperature. Construct the autoclave assembly in accordance with 134.7. Keep the autoclave pressure at least 60 psi (413.7 kPa) below the critical pressure of the refrigerant used.) (**Warning**—Chemicals and solvents used in this test method may be hazardous. Conduct this test with adequate ventilation. Keep flammable solvents away from open flames. Limit personal exposure through the use of protective clothing, gloves, and goggles.

NOTE 13—If necessary, determine the nonvolatile percent of the refrigerant, the limits of which are determined by mutual agreement between user and producer.

136. Test Specimen Preparation

136.1 Prepare eight random coils having dimensions of approximately $\frac{5}{8}$ by $1\frac{1}{8}$ in. (16 by 41 mm) from eight lengths of wire each containing 0.6 ± 0.1 g of insulation. For sizes finer than 0.0403 in. (1.024 mm) (AWG 18), use additional layers to obtain the required mass of insulation (0.6 ± 0.1 g).

137. Procedure

137.1 Anneal the eight coils in an oven at $150 \pm 3^\circ\text{C}$ ($302 \pm 5^\circ\text{F}$) for 15 ± 1 min. Remove specimens from oven with tongs and cool to room temperature.

137.2 Clean the eight coils thoroughly by immersing and agitating in petroleum ether or other suitable wash solvent. Avoid subsequent contamination.

137.3 Dry the coils in a forced air oven for 15 ± 1 min at $150 \pm 3^\circ\text{C}$ ($302 \pm 5^\circ\text{F}$).

137.4 Remove the specimens from the oven with tongs and allow to cool in a desiccator for a minimum of 30 min.

137.5 Transfer specimens with tongs to an analytical balance and weigh to the nearest 0.1 mg.

137.6 Place specimens in the siphon extraction cup below the overflow height of the siphon.

137.7 Suspend the extraction cup 1 ± 0.25 in. (25 ± 6 mm) below the condenser and seal the autoclave.

137.8 Purge autoclave for 30 s with refrigerant under a pressure of 1 psi (6.9 kPa), or evacuate autoclave for a minimum of 5 min with the vacuum pump.

137.9 Charge the pressure vessel with 1.54 ± 0.055 lbs (700 ± 25 g) of refrigerant. It may be necessary to place the pressure vessel in an ice bath to admit the required amount of refrigerant.

137.10 Refer to Note 14. Place the loaded and sealed pressure vessel on or in the heat source and connect the water supply, the drain line, and the overpressure shut-off switch to the pressure vessel.

137.11 Adjust the heat and water flow to maintain an adjusted reflux rate of 15 to 25 cycles per h for 6 ± 0.1 h. A sudden decrease in pressure is noted at the end of each cycle.

NOTE 14—In order to avoid any cycling irregularities, the autoclave pressure should be kept below the critical pressure of the refrigerant (Table 9). For example, the critical gage pressure of monochlorodifluoromethane is 710 psi (4.90 MPa). Avoid a variance in temperature of the cold water supply to prevent a change in the rate of cycling.

137.12 During the extraction time, place a clean aluminum weighing dish in an oven at $150 \pm 3^\circ\text{C}$ ($302 \pm 5^\circ\text{F}$) for 15 ± 1 min. Cool for a minimum of 30 min in a desiccator and weigh. Store this aluminum weighing dish in the desiccator until needed.

137.13 After completion of the extraction time, disconnect the heat source, water lines, and overpressure control. Remove the pressure vessel from the heat source and liquefy all the refrigerant by placing the autoclave in a cold environment until the pressure gage reads 0 psi, and then open the autoclave while in a clamped position.

137.14 Rinse the coils and siphon cup twice, each rinse being approximately 100 mL, with petroleum ether or other suitable wash solvent into the autoclave.

137.15 Evaporate the refrigerant slowly to within approximately 0.25 in. (6 mm) from the bottom of the vessel. Wash the walls of the pressure vessel with two successive rinses of 100 mL each of petroleum ether or other suitable wash solvent. Evaporate the solvents in a hood or in a well ventilated area to within 0.25 in. (6 mm) from the bottom of the vessel. Then transfer the liquid sample by pouring it into the predried tared aluminum weighing dish, along with rinse, evaporate to dryness at $150 \pm 3^\circ\text{C}$ ($302 \pm 5^\circ\text{F}$) for 1 h, and then cool to room temperature in a desiccator for a minimum of 30 min.

137.16 Transfer the aluminum weighing dish using tongs to an analytical balance and weigh to the nearest 0.1 mg. Subtract the tare weight of the aluminum weighing dish to obtain the weight of the extracted material.

137.17 Completely remove the film insulation from the conductor by immersing the wire in a suitable chemical stripper. Keep the immersion time to a minimum to avoid chemical attack on the conductor. Rinse the conductor in a suitable solvent or water, or both, to remove the chemical stripper and remnants of insulation. Rinse the conductor with alcohol.

137.18 Dry the conductor in an oven at $150 \pm 3^\circ\text{C}$ ($302 \pm 5^\circ\text{F}$) for 15 ± 1 min.

137.19 Remove the conductor from the oven with clean tongs and allow to cool in a desiccator for a minimum of 30 min.

137.20 Transfer the conductor to an analytical balance and weigh to the nearest 0.1 mg. Subtract the conductor weight from the initial specimen weight to obtain the weight of film insulation.

138. Calculation

138.1 Calculate the percent extractables as follows:

$$A = B/C \times 100 \quad (9)$$

where:

A = percent extractables,

B = total residue weight (see 137.16), and

C = weight of film insulation.

139. Report

139.1 Report the following information:

139.1.1 Identification of the specimen,

139.1.2 Nominal conductor size,

139.1.3 Conductor type,

139.1.4 Insulation type,

139.1.5 Build,

139.1.6 Refrigerant type, and

139.1.7 Percent extractables.

140. Precision and Bias

140.1 This test method has been in use for many years, but no information has been presented to ASTM upon which to base a statement of precision. No activity is planned to develop such information.

140.2 This test method has no bias because the quantity of extractables of magnet wire by refrigerants are based solely in terms of this test method.

FILM ADHERENCE AND FLEXIBILITY

141. Scope

141.1 This test method provides the procedure for evaluating the adherence and flexibility of the insulating film on round, rectangular, or square film-insulated magnet wire. Since adherence and flexibility are interrelated, they are evaluated by the same test, or a combination of elongation and mandrel tests.

142. Terminology

142.1 *Definitions of Terms Specific to This Standard:*

142.1.1 *crack in film coating, n*—an opening in the coating which exposes the bare-conductor to view at the specified magnification.

142.1.2 *film adherence and flexibility (of magnet wire), n*—a measurement which indicates the degree to which film insulated magnet wire may be mechanically stressed without visible cracks in the film or loss of adhesion to the conductor.

143. Significance and Use

143.1 During the winding of film-insulated magnet wire, some elongation of the insulating film occurs. Good film adherence and flexibility are essential to maintain the integrity

of the insulation. These properties depend on the cure of the film coating and the condition of the conductor surface. Evaluation provides an indication of the quality of the cure and a measure of the suitability of the film-insulated wire for further processing.

144. Apparatus

144.1 Means for rotating mandrels at a specified speed while maintaining suitable wire tension.

144.2 *Suitable Mandrels* of the diameter specified.

144.3 *Suitable Equipment* for elongating the wire to a predetermined amount at a specified rate.

144.4 *A Microscope*, or other magnifiers providing from six to fifteen times magnification as required.

145. Procedure (Round Wire, 4 AWG and Finer)

NOTE 15—The combination of elongation and mandrel sizes used in this test method is arbitrary and is usually established by industry practice. The mandrel diameters are ordinarily specified as integral multiples of the nominal conductor diameter except when the wire is wound on itself.

145.1 *Adherence:*

145.1.1 Unless otherwise specified elongate a wire specimen having an effective length of 10 ± 0.1 in. (250 ± 2.5 mm) to a predetermined length at the rate of 10 to 12 in./min (250 to 305 mm/min).

145.1.2 When a “sudden jerk” is specified, elongate a wire specimen having an effective length of 10 ± 0.1 in. (250 ± 2.5 mm) to a predetermined length at the rate of 12 to 16 ft/s (3.7 to 4.9 m/s).

145.1.3 After elongating as required in Table 14, examine the wire for loss of adherence as indicated when the insulation visibly separates from the wire (often as a tube) or when it is possible to completely or partially achieve such separation when the wire is held between the thumb and forefinger under slight pressure and subjected to lateral motion between the two fingers. (See Section 147.)

145.2 *Flexibility:*

145.2.1 Wind the elongated specimen with sufficient tension to form it around a mandrel of specified diameter being careful to avoid twisting or further elongation. Wind at a uniform speed and do not exceed 240 rpm. Ten turns closely spaced, or a 1 in. (25.4 mm) length along the mandrel, whichever is less, constitutes a flexibility specimen.

145.2.2 After winding on the mandrel, evaluate the specimen by examining the wire for cracks in the film coating (separations which expose the conductor) using the specified magnification in Table 14.

146. Procedure (Rectangular, Square, and Round Wire Larger Than 4 AWG)

146.1 Elongate a specimen having an effective length of 10 ± 0.1 in. (250 ± 2.5 mm) according to Table 14.

146.2 Examine the specimen with normal vision for cracks in the film coating through which the conductor is visible.

147. Report

147.1 Report the following information:

147.1.1 Identification of the specimen, including nominal conductor size, conductor type, insulation type, and build,

TABLE 14 Elongation Requirements

AWG Size	Elongation Rate	Minimum Elongation, %	Mandrel Diameter	Examined With
Copper				
Rectangular, square or <4 AWG round	12 ± 1 in./min (300 ± 25 mm/min)	30	None	Normal vision
4 to 9	12 ± 1 in./min (300 ± 25 mm/min)	30	None	Normal vision
10 to 13	12 ± 1 in./min (300 ± 25 mm/min)	25	5×	Normal vision
14 to 30	Sudden Jerk	20	3×	Normal vision
31 to 44	Sudden Jerk	20 ^A	3×	6× to 10× Magnification
45 to 56	Sudden Jerk	Breaking Point	None	10× to 15× Magnification
Aluminum				
Rectangular, square or <4 AWG round	12 ± 1 in./min (300 ± 25 mm/min)	15	None	Normal vision
4 to 9	12 ± 1 in./min (300 ± 25 mm/min)	15	None	Normal vision
10 to 15	12 ± 1 in./min (300 ± 25 mm/min)	15	5×	Normal vision
16 to 20	Sudden Jerk	15 ^A	3×	Normal vision
21 to 25	Sudden Jerk	10 ^A	3×	Normal vision

^AOr to the breaking point, whichever is less.

147.1.2 Loss of adherence as indicated (See 145.1.3.),

147.1.3 Pass or fail mandrels are specified in Table 14, and

147.1.4 Description of visual observation of failure or other anomalies.

148. Precision and Bias

148.1 No information is presented about the precision or bias of this test method for observing the flexibility of magnet wire because the test results are non-quantitative.

FORMABILITY

149. Scope

149.1 Formability is determined by the following methods: Elastic Ratio (see Section 152), Low Stress Elongation (see Section 153), and Springback (see Section 154). These test methods provide an indication of formability for round, rectangular or square film-insulated (copper or aluminum) magnet wire, which is wound by the user into a large variety of electromagnetic devices. On occasion it may be desirable to test bare or stripped wires by these test methods since insulations generally tend to affect the apparent formability. (See Specifications B 3, B 43, B 324 and B 609/B 609M.)

150. Terminology

150.1 *Definitions of Terms Specific to This Standard:*

150.1.1 *formability (of magnet wire), n*—that characteristic of magnet wire which permits it to maintain the shape into which it has been formed.

150.1.2 *windability (of magnet wire), n*—that characteristic which allows film-insulated magnet wire to be manufactured into a coil with a minimum of physical and electrical damage and the maximum of formability and compaction.

150.1.3 *work hardening of magnet wire, n*—the loss of formability resulting from the bending or stretching of magnet wire.

150.1.4 Other terms used in these methods can be found in Terminology E 6.

151. Significance and Use

151.1 Maximum formability is desirable because it facilitates winding more compactly, yields coils that will retain their shape best after removal from the winding forms, permits the

most rapid possible winding with minimum force, minimum wire breakage, and reduced abrasive effects. Each of these test methods provides a more significant measure of formability than do tests for hardness, tensile strength, or total percentage of elongation.

151.2 The test methods do not necessarily cover identical zones of the total stress-strain region. The Springback method employs mild bending, hence a combination of elongation and compression. The Low Stress Elongation method employs very slight elongation and the Elastic Ratio method employs the greatest elongation. Both the Low Stress Elongation and Springback methods allow the deformed film-insulated magnet wire to return partially or entirely to the unstressed condition, while the Elastic Ratio method does not.

152. Elastic Ratio Method

152.1 *Summary of Test Method*—The conductor is slowly elongated to break and a stress-strain diagram is recorded by the elongating instrument. The ratio of load at 5 % elongation divided by load at break, expressed as a percentage value, is defined as the elastic ratio. This ratio shall be at a minimum for best winding at high speeds since the conductor must be able to elongate when being wound. Elongation of over 5 % is common during winding.

152.2 *Significance and Use*—This test method is applicable to all sizes and shapes of copper and aluminum wire. The material, film build, and cure of insulation on the conductor influence results, normally causing it to be less formable than when tested bare.

152.3 *Apparatus*—Tensile testing machines that conform to the requirements of Practices E 4 shall be used. The instrument shall be capable of recording or of indicating load and elongation simultaneously with a full scale bias of within 0.5 % in each range. The jaws shall be so designed as to preclude slippage or breaking at the jaw.

152.4 *Test Specimen Preparation:*

152.4.1 Cut the specimen and handle so no bending is done except for straightening with a minimum amount of work hardening prior to insertion in the jaws. Absolutely no elongation of the specimen is permissible prior to test. Elongate a specimen with an effective length of 10 ± 0.1 in. (250 ± 2.5 mm).

152.4.2 Determine the dimensions of the conductor after using a suitable means of removing the insulation and not deforming the conductor surface. Microscopic measurement of a properly mounted specimen may also be used. Determine dimensions of the film-insulated magnet wire.

152.5 *Procedure*—After insertion of the specimen in the jaws, eliminate noticeable curvature or slack of wires finer than 0.032 in. (0.813 mm) (AWG 20) prior to testing by applying a load not to exceed 2 % of the load required to break the specimen. Determine the initial specimen length after removing the slack in the specimen. The rate of elongation shall not exceed 10 in./min (250 mm/min). Divide the load obtained at 5 % elongation, under stress, by the load at break; this quotient, multiplied by 100, is the elastic ratio. An automatic recording instrument is recommended. The range of the instrument used in this test method shall be so chosen that load values and elongation percentages can be read on the recording with a precision of 1 %.

152.5.1 Make three tests and compute the average elastic ratio.

152.6 *Report*—Report the following information:

152.6.1 Identification of the specimen,

152.6.2 Specimen dimensions, both film-insulated magnet wire and conductor,

152.6.3 Individual elastic ratios,

152.6.4 Average elastic ratio,

152.6.5 Average load at break,

152.6.6 Average percentage elongation at break,

152.6.7 Length of specimen between jaws before test,

152.6.8 Load range scale used in test, and

152.6.9 Report specimen dimensions and average percentage elongation to three significant figures.

152.7 *Precision and Bias*:

152.7.1 This test method has been in use for many years, but no information has been presented to ASTM upon which to base a statement of precision. No activity is planned to develop such information.

152.7.2 This test method has no bias because the value for elastic ratio of magnet wire is determined solely in terms of this test method.

153. Low Stress Elongation (LSE)

153.1 *Scope*—See 149.1.

153.2 *Summary of Test Method*:

153.2.1 The specimen is elongated to a specified stress per unit cross-sectional area. The permanent unstressed elongation resulting from this stress is taken as a measure of formability of the film-insulated magnet wire. The larger the value, the greater the formability of the wire.

153.3 *Significance and Use*—The permanent deformation measured at these low unit stresses is an indication of the ability of the wire to absorb bends and longitudinal twists during winding. This test method is similar to Test Method B 279, which is used for conductors.

153.4 *Apparatus*—Tensile testing machines used for the LSE test shall conform to the requirements of Practices E 4.

153.5 *Test Specimens Preparation*:

153.5.1 Remove the test specimens from the finished reel or coil with a minimum amount of handling and distortion,

retaining as much as possible the original curvature of the package. Test specimens having the full cross-sectional area of the wire shall be used. Straighten the test specimens carefully by hand with a minimum amount of distortion and work hardening. Improperly prepared test specimens often cause unsatisfactory results. The standard gage length for the measurement of LSE of wire shall be 10 ± 0.1 in. (250 ± 2.5 mm). The total length of the specimens shall be at least equal to the gage length plus the length of wire required for the full use of the grips employed.

153.5.2 Test a minimum of three specimens.

153.6 *Procedure*:

153.6.1 Clamp one end of the wire specimen in the movable grip of the tester, and the opposite end in the stationary grip. The distance between the wire grips must be 10 ± 0.1 in. (250 ± 2.5 mm).

153.6.2 Apply an initial stress to the specimen under test to remove any slight bend in the wire, and adjust the elongation measuring device to zero. The initial stress is 7500 psi (51.7 MPa) for copper and 4000 psi (27.6 MPa) for aluminum based on the measured cross-sectional area of the conductor.

153.6.3 Increase the stress to the specified value for the type wire being tested and hold for 30 ± 1 s. Increase the stress to 15 000 psi (103.4 MPa) for copper and 8000 psi (55.2 MPa) for aluminum based on the measured cross-section of the conductor.

153.6.4 Return the stress to the initial stress value and read the permanent elongation on the measuring device.

153.6.5 Record the LSE as a percent of the original 10-in. (250-mm) nominal specimen length.

153.7 *Report*—Report the following information:

153.7.1 Identification of the specimen,

153.7.2 Nominal conductor size,

153.7.3 Conductor type,

153.7.4 Insulation type,

153.7.5 Build,

153.7.6 Specimen dimensions, both insulated and bare, determined in accordance with 152.5,

153.7.7 Required loads, employed,

153.7.8 Individual LSE values, and

153.7.9 Average LSE.

153.8 *Precision and Bias*:

153.8.1 This test method has been in use for many years, but no information has been presented to ASTM upon which to base a statement of precision. No activity is planned to develop such information.

153.8.2 This test method has no bias because the value for LSE of magnet wire is determined solely in terms of this test method.

154. Springback Test (AWG 14-30)

154.1 *Scope*—See 149.1.

154.2 *Significance and Use*—The film-insulated magnet wire is wound under mild stress on a prescribed mandrel. After removing the load, the amount of springback is measured. Three mandrel diameters are used, depending upon the wire size; therefore a continuous relationship does not exist between wire diameter and springback. For best formability, minimum springback is desired.

154.3 *Apparatus*—The apparatus¹⁹ consists of the mandrels specified in Table 15 mounted on a horizontal axis with provision for rotating uniformly at a rate of 5 to 10 rpm. The springback scales are graduated into 120 segments since the magnet wire is wrapped three times around the specified mandrels. The radians on the springback scales are drawn from the theoretical centers of the relaxed coils. Examples of suitable instruments are shown in Figs. 11-13.

154.4 *Test Specimen:*

154.4.1 Remove the wire to be tested from the reel or package in such a way that it is not subjected to additional bends or elongation. Wind on the mandrel during test in the same direction as originally coiled. The length of specimen must be greater than three times the circumference of the mandrel so that the weight attached to the free end will hang without contacting the mandrel at the end of the winding operation.

154.4.2 Determine the dimensions of the specimen in accordance with 152.4.

154.4.3 Test a minimum of three specimens.

154.5 *Procedure:*

154.5.1 Lock the mandrel in position so that the hole for fastening the wire is in a vertical position directly above the axis of rotation and at the 0° scale mark. Insert the wire in the hole of the correct mandrel and bend sharply to 90° at the hole. Attach the weight specified in Table 15 to the wire.

154.5.2 Layer-wind the wire by turning the mandrel three complete revolutions in the counterclockwise direction. Make a mark on the wire on the last turn opposite the zero mark. Remove the weight while holding the wire to prevent any unwinding, and cut the wire 0.5 in. (13 mm) beyond the mark and allow it to unwind slowly by placing a pencil or similar object to the left of the upturned 0.5 in. (13 mm) length and guiding the end so it will uncoil very slowly. The angle through which the mark on the last turn has moved on the scale is the degree of springback, measured to the nearest 1°. This represents the number of degrees of springback per turn of the wire. The softer the wire, the less the springback. If the wire uncoils rapidly, false values will be obtained and such results must be discarded.

154.6 *Report*—Report the following information:

- 154.6.1 Identification of the specimen,
- 154.6.2 Nominal conductor size,

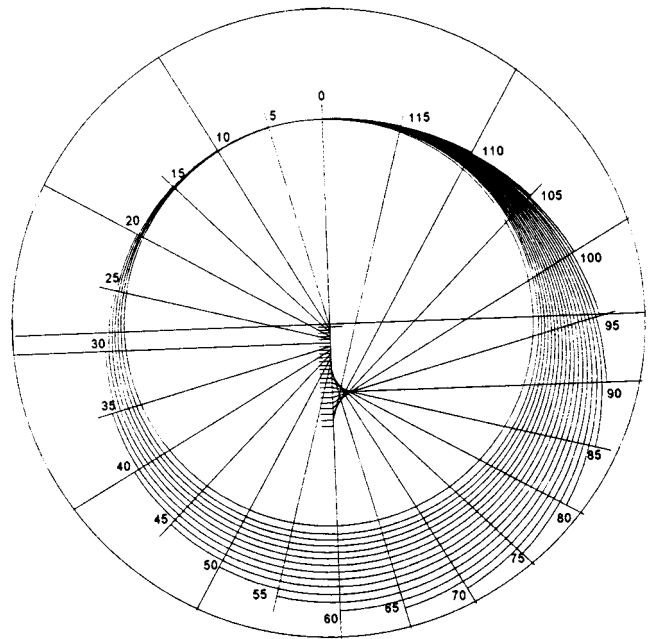

FIG. 11 Details of the Scale Graphic Line Center of Origin for Incremental Degrees of Springback

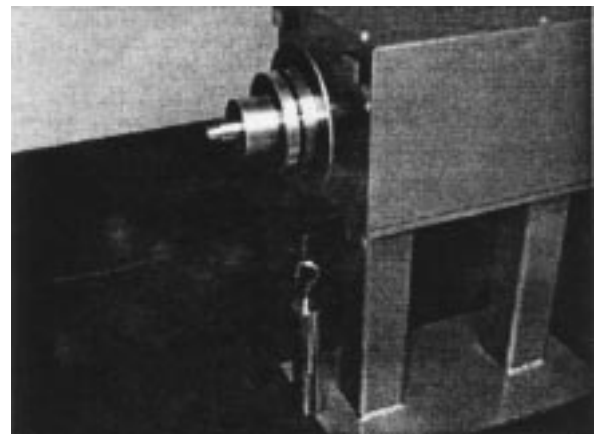

FIG. 12 Springback Tester After Winding a Coil Under Tension

- 154.6.3 Conductor type,
- 154.6.4 Insulation type,
- 154.6.5 Build,
- 154.6.6 Specimen dimensions, both insulated and bare, and
- 154.6.7 Degrees of springback, individual and average.

154.7 *Precision and Bias:*¹³

154.7.1 In comparing two averages from five specimens, the differences should not exceed the critical differences in Table 16, in 95 cases out of 100 when all of the observations are taken by the same well-trained operator using the same piece of test equipment and specimens randomly drawn from the same sample of material.

154.7.2 *Precision*—Two averages of observed values should be considered significantly different at the 95 % probability level if the difference equals or exceeds the critical differences listed in Table 16.

154.7.3 *Bias*—The true values of the properties listed in Table 16 can only be defined in terms of specific test methods.

TABLE 15 Parameters for Springback Test^A

Ranges of Bare Wire Diameters		AWG Range, s	Mandrel Diameter (± .005 in.)		Tension on Wire (± 2 %)	
in.	mm		in.	mm	oz	N
0.0641 to 0.0320	1.63 to 0.81	14–20	3.25	82.6	16	4.45
0.0285 to 0.0201	0.73 to 0.51	21–24	1.88	47.6	4	1.11
0.0179 to 0.0159	0.46 to 0.40	25–26	1.88	47.6	2	0.56
0.0142 to 0.0100	0.36 to 0.25	27–30	0.75	19.1	2	0.56

^AFor fractional sizes use the mandrel and tension for the next full AWG size of smaller diameter.

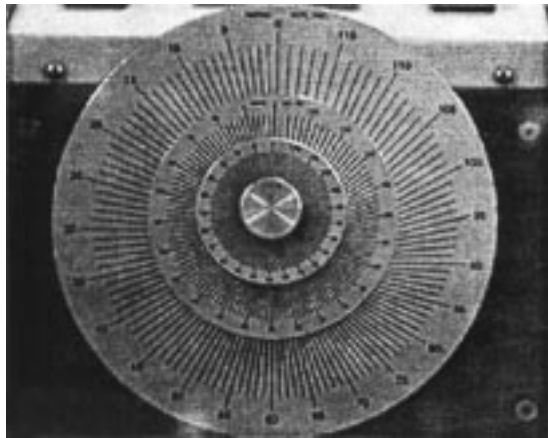

FIG. 13 Photograph of Possible Appearance of the Springback Scales

TABLE 16 Critical Differences—Degrees of Springback^A

Name of Properties	Number of Observations in each Average	Single Operator Precision	Within Laboratory Precision	Between Laboratory Precision
Springback, Aluminum Wire	3	2.3	4.1	6.4
Springback, Copper Wire	3	2.2	4.7	5.4

^AThe critical differences were calculated using $t = 1.960$, which is based on infinite degrees of freedom.

Within this limitation, the procedure for determining this property has no known bias.

155. Springback Test for Rectangular, Square and Round Wire Larger than AWG 14 Film-Insulated Magnet Wires

155.1 Select a length of wire at least 48 in. (1200 m) long and remove from the package with as little bending as possible. Carefully straighten by hand and cut into 16-in. (400-mm)

specimens. Work hardening should be minimized. Elongation by machines shall not be used for straightening.

155.2 Test Apparatus:

155.2.1 The springback is determined by means of the apparatus shown in Fig. 14 consisting essentially of two smooth jaws, one fixed (2), the other movable (1), and a sector graduated in degrees (5) with the 0 to 10° sector of the scale further graduated in 0.5° increments.

155.2.2 Place the test apparatus in a horizontal position. The graduated sector is an arc placed in a plane at 90° to the clamp faces. Its center is located at the outer edge of the fixed jaw (3). The lever arm whose fulcrum is placed at the center of the arc can move over the graduated sector in the horizontal plane. The lever arm shall have a sharp pointer or marker to clearly indicate the springback. On the lever arm which has a 12-in. (305-mm) length graduated in tenths of an inch (2.5 mm) whose origin is at the fulcrum, there is a movable slider (4).

155.3 Procedure:

155.3.1 Bend the wire specimens in the same direction that the wire was bent when packaged.

155.3.2 Measure the conductor thickness (or round wire diameter) for determining the actual position of the slider. Multiply the thickness or diameter by 40 to locate the slider to a specific dimension along the lever arm, to the nearest 0.1 inches. Tighten the wire moderately between the jaws with the direction of the former curvature up, or away from the operator, to leave a free length of specimen extending approximately 0.5 in. (12.0 mm) beyond the slider knife edge.

155.3.3 Gently bend the wire to 30°, starting at the horizontal position (the 30° scale mark, position 1), (to the 0° scale mark, position 2). Bend the wire for no less than 2 s nor more than 5 s. Hold the specimen at the 0° point (a 30° bend) for a maximum of 2 s.

155.3.4 Return the lever arm gently in the reverse direction at the same angular rate at which it was raised until the slider

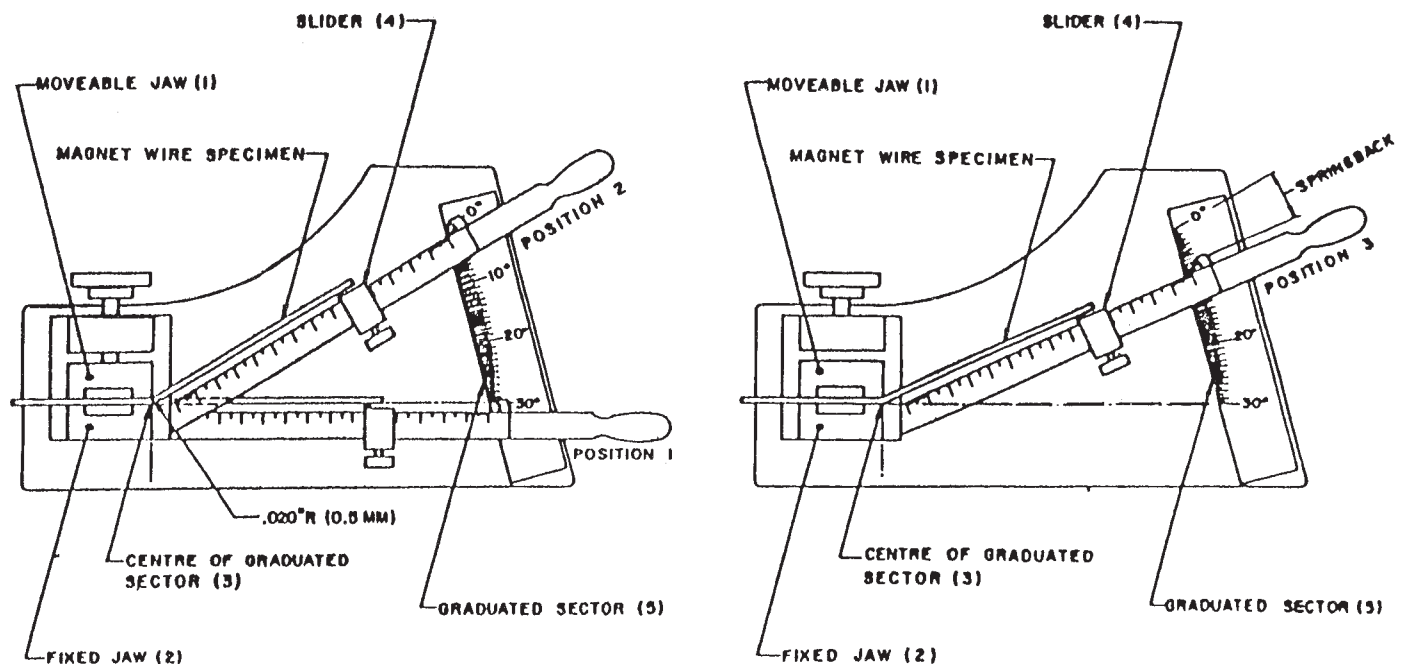

FIG. 14 Apparatus for Measurement of Springback

knife edge moves away from the wire specimen. Raise the lever arm until the slider knife edge just contacts the wire specimen without moving it. The lever arm pointer indicates the springback.

155.3.5 Test a total of three specimens.

155.4 *Value of Springback*—The value of the springback in angular degrees (°) is read directly on the scale shown by the position of the lever arm on the graduated sector in position 3.

NOTE 16—If the results of the three consecutive specimens cut from a continuous length of wire differ by more than 0.5°, retesting is recommended.

155.5 *Report*—Report the following information:

155.5.1 Identification of specimen,

155.5.2 Nominal conductor size,

155.5.3 Conductor type,

155.5.4 Insulation type,

155.5.5 Build, and

155.5.6 Value of springback, individual and average in degrees (°).

155.6 *Precision and Bias*:

155.6.1 This test method has been in use for many years, but no information has been presented to ASTM upon which to base a statement of precision. No activity is planned to develop such information.

155.6.2 This test method has no bias because the value of springback of large round, rectangular and square magnet wire is determined solely in terms of this test method.

HEAT SHOCK

156. Scope

156.1 This test method for round, rectangular, or square film-insulated magnet wires is used to evaluate the resistance to cracking of the film coating under stress when subjected to rapid temperature changes.

157. Terminology

157.1 *Definitions of Terms Specific to This Standard*:

157.1.1 *heat shock resistance (of magnet wire), n*—the ability of film insulation on magnet wire to resist cracking when exposed to rapid temperature change after being physically stressed.

158. Significance and Use

158.1 Film insulation of magnet wire is stressed during winding and forming operations. It is further stressed by temperature changes in processing of windings, and normal operation of the apparatus. This test is used to evaluate the resistance to cracking of the film insulation upon exposure to rapid temperature changes.

159. Apparatus

159.1 *Forced-Air Oven*, see Specification D 5423.

159.2 *Mandrels*, for round wire.

159.3 *Tension Tester*, or other elongating device for pre-stretching wire as required (see Test Methods E 8).

160. Test Specimen

160.1 *Round Wire 4 AWG and Finer*:

160.1.1 Wind the prestretched film-insulated magnet wire around the specified mandrels (see Table 14) with sufficient tension to ensure that the wire conforms to the mandrel. Ten closely spaced turns on each mandrel constitute a specimen.

160.1.2 Load the specimen, suspended from a suitable rack, into a forced air oven at a prescribed temperature for 30 ± 3 min. Generally, the temperature will be 20°C above the rated temperature unless otherwise specified. After conditioning, remove specimens and cool to room temperature. Examine the specimens for cracks in accordance with Table 14. Visible evidence of a crack(s) constitutes a failure.

160.2 *Round Wire, Larger Than 4 AWG, Rectangular, and Square Wire*:

160.2.1 Elongate individual specimens not less than 15 % for copper magnet wire or not less than 10 % for aluminum magnet wire at a rate of 12 ± 1 in./min (300 ± 25 mm/min).

160.2.2 Load the elongated specimens, suspended from a suitable rack, into a circulating air oven at a prescribed temperature for 30 ± 3 min. Generally, the temperature will be 20°C above the rated temperature unless otherwise specified. After conditioning, remove specimens and cool to room temperature. Examine the specimens for cracks in accordance with Table 14. Visible evidence of a crack(s) constitutes a failure.

161. Report

161.1 Report the following information:

161.1.1 Identification of specimen,

161.1.2 Nominal conductor diameter or AWG number (round),

161.1.3 Thickness and width (rectangular or square),

161.1.4 Conductor type,

161.1.5 Insulation type,

161.1.6 Build,

161.1.7 Conditioning temperature,

161.1.8 Elongation,

161.1.9 Mandrel size, and

161.1.10 Record results as pass or fail.

162. Precision and Bias

162.1 No information is presented on precision or bias of heat shock testing of magnet wire because the test results are non-quantitative.

OILINESS

163. Scope

163.1 This test method determines whether film-insulated magnet wire has the proper lubricity to permit satisfactory winding of coils.

164. Significance and Use

164.1 The test result is indicative of the amount of spooling oil present on the wire. Wire with insufficient lubricity tends to produce oversize, uneven windings. Excessively oiled wire tends to fall into the space at the coil ends rather than maintaining a compact helix. The results for the minimum lubricity test do not necessarily differentiate between oil content and other factors (that is, type of film, degree of bake,

moisture, etc.) which also affect frictional characteristics. The test method is suitable for use in manufacturing control, specification acceptance, and service evaluation.

165. Apparatus

165.1 *Minimum Lubricity:*

165.1.1 *Friction Tester*, consisting of a motor-driven 0.625 ± .005-in. (16-mm) diameter polished steel mandrel which can be rotated at 160 rpm.

165.1.2 *Dereeling Mechanism*, capable of maintaining tensions between 0 and 10 oz (0 and 300 g) on the wire as shown in Fig. 15.¹⁹

165.1.3 *Measuring Scale*, having a minimum of 1/32 in. (1 mm) graduations.

165.2 *Maximum Oil:*

165.2.1 *Dereeling Mechanism.*

165.2.2 *Spring-Loaded Pinch-Type Clamp*, the type generally used as a component of over-end dereelers equipped with 0.5-in. (13-mm) square pads made of No. 16R3 felt in accordance with Specification D 2475.

165.2.3 *Spring-Type Balance*, suitable for measuring zero to approximately 3 lb (1.4 kg) in 0.25 lb (100 g) increments.

165.2.4 *Unsize Cotton Sheeting*, meeting Type I requirements of Federal Specification CCC M 911.

165.2.5 *Waxed Paper*, or equivalent.

NOTE 17—The dereeling mechanism must be so constructed that no wiping action takes place before the wire passes through the cotton sheeting wiping pad.

166. Test Specimen

166.1 Test specimens shall consist of unopened full unit containers.

166.2 Test specimens shall be taken directly from containers (spools, pails), so as to prevent contamination or evaporation loss of volatile constituents in the oil.

167. Procedure

167.1 *Minimum Lubricity*—After removing all trace of oil or other lubricant from the rotating mandrel, secure the wire end to the mandrel at a point approximately 1 in. (25 mm) to the left of the vertical wire position as indicated in Fig. 15. With a fixed supply position and rotating mandrel, proceed to wind the wire onto the mandrel, maintaining uniform tension as shown in Table 17. Continue to wind the wire onto the mandrel until it climbs up over the preceding turn and falls back to the vertical. Measure the length of the close-spaced single-layer helix to the nearest 1/32 in. (1 mm).

167.2 *Maximum Oil*—After determining that the tension required to open the pinch clamp is between 1.5 and 2 lb (0.7 and 0.9 kg), fold a 4- by 8-in. (100- by 200-mm) piece of cotton sheeting into a pad around the wire so that it lies between two four-layer pads of cloth. Position firmly in a clamp with a waxed paper barrier between the sheeting and the felt pads. Pass the wire through the firmly held pad at a speed not exceeding 200 ft/min (61 m/min). Unfold the pad and observe immediately, using reflected or transmitted light to determine the number of layers of oil penetration. A definite oil smear will result from the wicking action of the oil in the cloth. Discoloration due to removal of insulating film shall be disregarded. The amount of wire tested shall be based on a constant amount of surface area of 0.5 ± 0.01 m² unless otherwise agreed upon between user and supplier.

168. Report

168.1 Report the following information:

168.1.1 Identification of the specimens,

168.1.2 Number of specimens tested,

168.1.3 Minimum lubricity, value of individual tests in 1/32 in. (1 mm), and

168.1.4 Maximum oil, weights of wire tested and number of layers oil penetration.

169. Precision and Bias

169.1 This test method has been in use for many years, but no information has been presented to ASTM upon which to

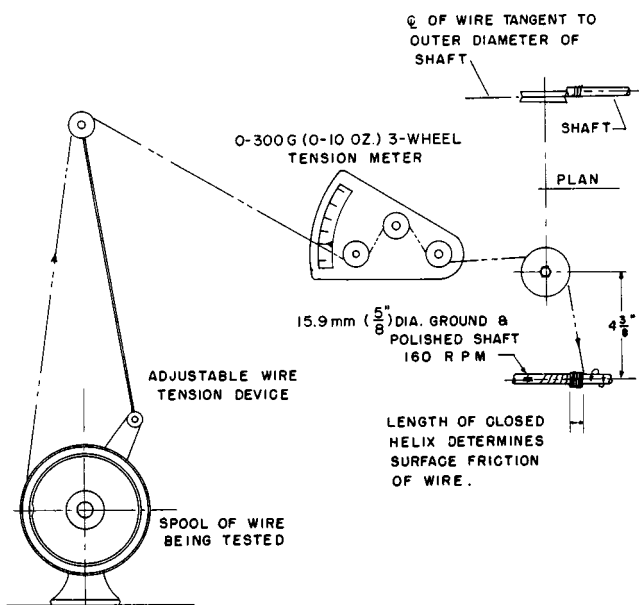

FIG. 15 Film-Coated Wire Friction Test Set

TABLE 17 Oiliness Test, Required Tension for Winding Wire Onto Mandrel

Wire Size, AWG	Tension	
	oz.	G
24	8 1/2	240
25	8 1/2	240
26	8 1/2	240
27	6 1/2	180
28	5	140
29	4 1/2	125
30	4	110
31	2 1/2	70
32	2	55
33	2	55
34	2	55
35	1	30
36	1	30
37	1	30
38	1	30
39	1	30
40	1	30
41	1	30

base a statement of precision. No activity has been planned to develop such a statement.

169.2 This test method has no bias because the value for the oiliness of magnet wire is determined solely in terms of this test method.

UNIDIRECTIONAL SCRAPE RESISTANCE

170. Scope

170.1 This test method determines the scrape resistance of film-insulated magnet wire by the unidirectional procedure. The test is suitable for film-insulated magnet wire with nominal diameters of 0.1019 to 0.0100 in. (2.59 to 0.25 mm).

171. Terminology

171.1 *Definitions of Terms Specific to This Standard:*

171.1.1 *scrape resistance, unidirectional (of magnet wire), n*—the load expressed in grams required to remove the film insulation under specified conditions.

172. Significance and Use

172.1 The unidirectional scrape test gives an indication of the overall resistance of film-insulated magnet wire to physical damage. It also provides a qualitative indication of the concentricity of the film insulation.

173. Apparatus

173.1 *Scraping Device*¹⁹ using 0.009-in. (0.23-mm) diameter music wire meeting the requirements of Specification A 228/A 228M. The steel wire shall be held rigidly in the scraping device between two jaws without any sagging or curvature, at right angles to the test specimen. The wire to be tested shall be supported by a suitable anvil. The scraping action is in one direction at a constant speed of 16 ± 1.6 in./min (400 ± 40 mm/min). The equipment is capable of scraping the wire specimen approximately 4 in. (100 mm). The load at the end of the stroke is two times the initial load. The device shall be equipped with an electrical circuit that limits the current to 20 mA at approximately 7.5 ± 1.5 V dc between the film-insulated magnet wire and the steel wire scraper. The circuit shall be so designed that failure of the film insulation is detected and the device stopped when the film insulation is removed and the conductor exposed for a distance of approximately 0.125 in. (3 mm).

174. Test Specimen Preparation

174.1 Use two or more 15-in. (380-mm) long specimens. Straighten by elongating slightly, not over 1 %, to remove slight kinks. Wire with sharp bends, nicks, or any other obvious defects should not be used for this test.

175. Procedure

175.1 Wipe the specimen with a clean, dry, bleached, and unsized cheesecloth. Position the specimen over the supporting anvil. Secure the specimen by means of the clamping jaws. Connect the specimen to the detection circuit. Clean the steel wire with a suitable solvent to remove insulation particles and lubricants before each test (no abrasive medium shall be used).

175.2 Lower the weighted scraping device gently onto the surface of the specimen. The recommended initial weight is 90 % of the minimum specified values for the given size and build. Start the scraping action, subjecting the specimen to the increasing load.

175.3 After the test is terminated, multiply the initial weight by the value indicated from the graduated scale on the beam. This product is the “grams to failure” value for this test. If failure occurs in the first 1.5 in. (38 mm) of the specimen, adjust the weight to less than 90 % of the minimum specified value. If the specimen does not fail, increase the weight in steps of 20 % until failure is obtained. When the weight to cause failure has been determined, make three tests on each of two specimens by rotating each specimen on its axis 120° and 240°, respectively from the initial test. Average the six failure values to obtain the unidirectional scrape resistance of the wire sample.

NOTE 18—Exercise caution to avoid false values caused by insulation damaged by a prior test. For finer wire sizes, two readings 180° apart instead of the required three may be necessary.

176. Report

176.1 Report the following information:

176.1.1 Type and size of wire,

176.1.2 Build, and

176.1.3 Minimum and average unidirectional scrape resistance.

177. Precision and Bias

177.1 This test method has been in use for many years, but no information has been presented to ASTM upon which to base a statement of precision. No activity has been planned to develop such a statement.

177.2 This test method has no bias because the value for unidirectional scrape of magnet wire is determined solely in terms of this test method.

SOLDERABILITY

178. Scope

178.1 This test method determines the solderability of round film-insulated magnet wire with nominal diameters of 0.641 to 0.00049 in. (1.628 to 0.0125 mm) (AWG 14 through 56).

179. Terminology

179.1 *Definitions of Terms Specific to This Standard:*

179.1.1 *solderability (of magnet wire), n*—a measure of film-insulated magnet wire that relates to the ease and rapidity with which reliable soldered connections can be made without prior removal of the insulating film.

180. Significance and Use

180.1 The time and temperature required to make soldered connections without prior removal of the insulating film is a measure of solderability. The solderability of film-insulated magnet wire is necessary for production of reliable soldered connections. Solderability is influenced by film composition, degree of cure, thickness of insulation, size of wire, and composition of solder and flux.

181. Apparatus

181.1 *Thermally Insulated Solder Pot*¹⁸ with controls that will maintain the temperature of the solder within $\pm 3^{\circ}\text{C}$ ($\pm 5^{\circ}\text{F}$) of the required temperature. The immersing device shall be capable of immersing the specimen to an approximate depth of 1.25 in. (32 mm) on the vertical center line of the pot and hold it there for a specified time. The soldering equipment shall have a controlled immersion time ranging from less than 1 s to 15 s. The solder pot shall be able to operate within a temperature range of 315 to 650°C (600 to 1200°F).

181.2 *Soldering Flux*, composed of 90 parts denatured ethyl alcohol and 10 parts WW rosin.

181.3 *Test Specimen Holder* (see Fig. 16).

182. Procedure

182.1 For nominal wire sizes 0.0641 to 0.0050 in. (1.628 to 0.127 mm), (AWG 14 to 36), cut a single strand, straight length of wire to a 6-in. (150-mm) test specimen.

182.2 For nominal wire sizes 0.0045 to 0.00049 in. (0.114 to 0.0125 mm), (AWG 37 to 56), support the specimen of wire by means of a specimen holder (see Fig. 16).

182.3 Fill the pot with solder consisting of 60 % tin and 40 % lead. Set the controls to the required temperature. (**Warning**—Adequate ventilation is necessary when testing film-insulated magnet wire above the melt point of the insulation. This is even more critical when film insulated magnet wire is heated during processing, for example, soldering, hot staking.)

182.4 When the solder is melted, adjust the thermocouple so that the lower end is 1 in. (25 mm) below the solder surface and approximately 0.25 in. (6.0 mm) from the center line of the specimen.

182.5 Periodically check the position of the thermocouple with respect to the surface of the solder.

182.6 Set the timer to the required immersion time.

182.7 When the temperature of the solder has stabilized, scrape the dross from the top of the solder. If specified, wet the

specimen in the flux and then place it in the movable immersion fixture of the solderability tester.

182.8 Immerse specimens in the solder to a depth of approximately 1.25 in. (32 mm).

183. Evaluation

183.1 Allow the specimen to cool. Using a magnification of 6 to 10 \times for AWG 14 to 36 wire and 15 \times for AWG 37 to 56 wire and an illumination of 100 to 300 foot-candles (1080 to 3230 lm/m²) examine the lower 0.5 in. (13 mm) of the specimen. This lower 0.5 in. (13 mm) of the specimen shall show a continuous film of solder completely wetting the wire.

184. Report

184.1 Report the following information:

- 184.1.1 Nominal wire size,
- 184.1.2 Conductor material,
- 184.1.3 Type and build of insulation,
- 184.1.4 Solder composition,
- 184.1.5 Composition of flux (when used),
- 184.1.6 Temperature of solder,
- 184.1.7 Time of immersion in solder, and
- 184.1.8 Results and any visual observations or anomalies.

185. Precision and Bias

185.1 This test method has been in use for many years, but no information has been presented to ASTM upon which to base a statement of precision. No activity has been planned to develop such a statement.

185.2 This test method has no bias because the value for the solderability of magnet wire is determined solely in terms of this test method.

RESISTANCE TO INSULATING LIQUIDS AND HYDROLYTIC STABILITY OF FILM-INSULATED MAGNET WIRE

186. Scope

186.1 These test methods determine the resistance to insulating liquid and the hydrolytic stability of round, rectangular and square film-insulated magnet wire.

187. Significance and Use

187.1 History has proven conclusively that water, a breakdown product of cellulose, is the primary agent that causes deterioration of the magnet wire film-insulation in liquid filled electrical equipment. Sufficient time and temperature are required to break down the cellulose.

187.2 Moisture, time, and temperature directly affect magnet wire compatibility in an enclosed system. A short time hydrolytic stability screening test and a long-term compatibility test are necessary to evaluate the interaction or compatibility of the components.

187.3 Variations in the components used in this test also can affect the results. The characteristics of the transformer oil (with or without oxidation inhibitors such as Butylated Hydroxy Toluene (BHT)) and concentration of additives have a major impact. These transformer oil additives and their amounts need to be specified as well as the maximum amount

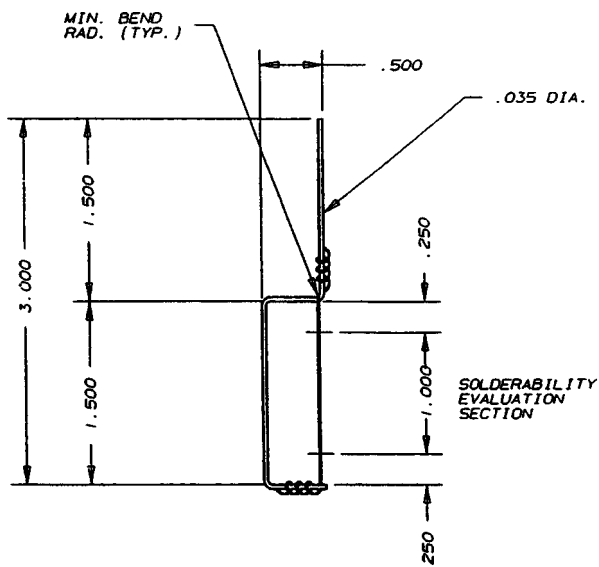

FIG. 16 Solderability Test Specimen Holder for AWG 37 through 56

moisture content of 5 ppm. The kraft paper used most is a diamond pattern epoxy (cyclo-aliphatic) coated Kraft paper between 3 and 15 mils thick. The thicker papers are more difficult to dry to less than 0.5 wt % moisture content. There are also thermally upgraded papers to consider. Variations in steel may also have effects. For these reasons, specifics of the components used in this compatibility test must be detailed in the reporting of results.

188. Apparatus

188.1 *Hydrolytic Stability in Insulating Liquid:*

188.1.1 *Forced-Air Oven* see Specification D 5423.

188.1.2 *Pressure Vessel*, stainless steel or glass lined vessels. Design the vessel to withstand a minimum pressure of 870 psi (6.0 MPa) and equipped with a rupture disk set at 800 psi (5.5 MPa) maximum. The inside dimensions are such that the specimens are completely immersed in the insulating liquid.

189. Reagents and Materials

189.1 *Round, Rectangular or Square Film-Insulated Magnet-Wire Test Specimens.*

189.2 *Transformer Oil or Insulating Liquid as agreed upon between the user and supplier.*

189.3 *Kraft Paper*, as agreed upon between the user and the supplier.

189.4 *Steel*, as agreed upon between user and supplier.

189.5 *Distilled Water.*

190. Components

190.1 Collect the materials to be used in the pressure vessel according to Table 18, unless otherwise agreed upon between purchaser and supplier.

190.2 The length of wire to provide the required volume of enamel can be calculated as follows:

$$V_f = 0.26 \% V \quad (10)$$

where:

V_f = volume of film-coating,

V = volume of pressure tube, mL \times 0.06102 in.³/mL, and

0.26 % = 0.0026 = established test constant from Table 18.

$$V_f = .0026 * V = \pi L (d_c^2 - d_b^2)/4 \quad (11)$$

and

$$L = 4 (0.0026) (V) (0.06102) / [\pi * (d_c^2 - d_b^2)] \quad (12)$$

and

$$L = (0.0002020) (V) / (d_c^2 - d_b^2) \quad (13)$$

TABLE 18 Pressure Vessel Components

Component	Pressure Vessel Volume, %
Transformer Oil	65 %
Kraft Paper	4 %
Magnet Wire Insulation	0.26 %
Steel	0.5 %
Distilled Water	0.06 %

where:

L = length of wire, in.,

d_c = diameter of coated wire, in., and

d_b = diameter of bare wire, in.

Example—Establishing 400 mL as pressure tube volume; with coated wire, $d_c = 0.0434$ in.; bare wire, $d_b = 0.0402$ in.:

$$L = 0.0002020 (400) / (0.0434^2 - 0.0402^2) \quad (14)$$

$$L = 302.0 \text{ in. of film-insulated magnet wire} \quad (15)$$

191. Transformer Oil Conditioning

191.1 For mineral oil type transformer oils, dry a quantity in excess of the 65 % of the total volume of the pressure vessel by heating to 50 to 55°C in an open container for a minimum of 16 h and then deaerate under a vacuum system at $\leq 15 \mu\text{m}$ (490 $\mu\text{in.}$) of mercury for 10 ± 1 min. Cool to room temperature in a desiccator to prevent any additional moisture absorption.

191.2 Process other dielectric liquids according to supplier recommendations to ensure the low moisture content limit.

191.3 Test the transformer liquid for ppm water or dielectric breakdown. The transformer liquid should be below 5 ppm of water tested according to Test Methods D 1533 or have a 30 kV minimum dielectric breakdown when tested according to Test Method D 877.

192. Round Wire Smaller Than 9 AWG, Test Specimens

192.1 Prepare fifteen dielectric specimens, in accordance with Table 9 and 72.1.

NOTE 19—The length of wire to form five of the dielectric twists will not be exposed to the oil and therefore should not be considered part of the (L) length of magnet wire calculated in 190.2).

192.2 Elongate five flexibility specimens by sudden jerk to 20 % and wrap on a 3 \times diameter mandrel in accordance with Table 14 and Section 145. Visually inspect using 6 \times -10 \times magnification. Remake any specimens found to have flaws.

192.3 Elongate four straight lengths by sudden jerk to 20 %. Visually inspect using 6 \times to 10 \times magnification. Remake any specimens found to have flaws.

192.4 Wind the additional wire length needed to satisfy insulation volume according to Section 190 into a shape that will fit into the pressure vessel.

193. Round Wire Larger than 10 AWG, Rectangular and Square Wire Test Specimens

193.1 Prepare eight dielectric specimens in accordance with 72.2.

193.2 Prepare five edge-bend specimens in accordance with Section 79. Visually inspect using 6 \times to 10 \times magnification. Remake any specimens found to have flaws.

194. Procedure

194.1 (1 Week Test)

194.1.1 Place the open pressure vessel containing the steel, paper, wire specimens, and remaining wire length needed to satisfy the requirements of (L) in Section 190.2, in an oven at $105 \pm 5^\circ\text{C}$ for 18 ± 0.5 h. Afterwards, apply the vacuum system at $\leq 15 \mu\text{m}$ (490 $\mu\text{in.}$) of mercury, for 10 ± 1 min.

194.1.2 Break the vacuum and remove five of the dielectric specimens while still hot. Place these dielectric specimens in a

desiccator. Cool to room temperature. Test these dried dielectric specimens for breakdown voltage according to Section 74.

194.1.3 Immediately add the dry deaerated insulating liquid (transformer oil) to the vessel. Add the distilled water to the transformer oil. Purge the vessel with enough dry nitrogen to exchange the volume of airspace above the liquid three to five times. Seal the vessel.

194.1.4 Heat the vessel to $150 \pm 5^\circ\text{C}$ for 168 ± 1 h.

Warning—Follow safety measures that are normally incorporated into aging procedures operating under both heat and pressure.

194.1.5 Cool the vessel to room temperature. Carefully open the vessel.

194.1.6 Remove five of the dielectric twist specimens, wipe off excess oil and test the dielectric breakdown voltage according to Section 74.

194.1.7 Remove the remaining five dielectric twist specimens and dry them at $125 \pm 3^\circ\text{C}$ for 30 ± 1 min. Cool the twists to room temperature and test the dielectric breakdown voltage according to Section 74.

194.1.8 Remove the wrapped flexibility specimens from the pressure vessel, wipe clean of excess oil, and visually inspect using $6\times$ - $10\times$ magnification.

194.1.9 Remove the 20 % snapped straight length samples from the pressure vessel and wrap around $1\times$, $3\times$, $5\times$ and $10\times$ mandrels. Examine the wound specimens under $6\times$ - $10\times$ magnification and record any visual observations.

194.1.10 Retest the dielectric breakdown voltage of the oil after the test according to Test Method D 877.

194.1.11 Examine all of the components in the system for any visible changes.

194.2 Procedure (28 Day Test)

194.2.1 Follow the 1 week resistance to insulating liquids and hydrolytic stability test procedure as outlined in 194.1 with the following exceptions:

194.2.2 Do not add the distilled water to the pressure vessel as described in 194.1.3.

194.2.3 Heat the vessel to $150 \pm 5^\circ\text{C}$ for 672 ± 1 h rather than as specified in 194.1.4. **Warning**—Follow safety measures that are normally incorporated into aging procedures operating under both heat and pressure.

195. Report

195.1 Report the results using the following spreadsheet format (Table 19):

TABLE 19 Sample Spreadsheet Format

Time Exposure at Elevated Temperature	Hours	
	before oil exposure	after oil exposure
Magnet Wire Identification		
Magnet Wire Properties	before oil exposure	after oil exposure
Preformed Mandrel Wraps 20 % Snap 3x	Section 192.2	Section 194.1.8
Dielectric Breakdown (n = 5)	Section 194.1.2	Section 194.1.6
Dielectric Breakdown after post test dry out (n = 5)	Section 194.1.7	
Post test Mandrel Wraps 1x, 3x, 5x, 10x	Section 194.1.9	
Visual observations of the magnet wire after test	Section 194.1.11	
Dielectric Liquid		
	after dry out	After test
Dielectric Breakdown	Section 191.3	Section 194.1.10
Moisture content (ppm) after dry out	Section 191.1.3	
Visual Observations of the oil after test	Section 194.1.11	
Kraft Paper Identification		
Visual Observations of the paper after test	Section 194.1.11	
Steel Identification		
Visual Observations of the steel after test	Section 194.1.11	

196. Precision and Bias

196.1 Precision—This test method has been in use for many years, but no information has been presented to ASTM International upon which to base a statement of precision. No activity is planned to develop such information.

196.2 Bias—This test method has no bias because the results for determining the resistance to insulating liquids and hydrolytic stability of film-insulated of magnet wire are determined solely in terms of this test method.

197. Keywords

197.1 bond strength; burnout; chemical resistance; coefficient of friction; continuity; completeness of cure; cut-through temperature; dielectric; dimensional measurement; dissipation factor; elastic ratio; electrical resistance; elongation; extractables; film adherence; film-insulated conductor; formability; heat shock; hydrolytic stability; low stress elongation; magnet wire; oiliness; overload resistance; scrape resistance; solderability; springback; thermoplastic flow; resistance to insulating liquids

APPENDIX

(Nonmandatory Information)

X1. SIPHON CUP

X1.1 A suitable cup may be made by using a 600-mL stainless steel beaker approximately 3.25 in. (83 mm) in diameter. Cut approximately 1.5 in. (38 mm) off the top of the beaker. Depress the bottom approximately 0.125 in. (3 mm) to facilitate effective drainage and drill a hole in the bottom-center position. Insert a stainless steel siphon tube in the bottom-center of the cup. Form the tubing along the bottom of the cup and up along one side to within 0.375 in. (9.5 mm) of the top. Make a uniform radius 180° bend back down along the side wall of the beaker. Bend the tubing back under the beaker so that the exit drain end is beneath the bottom center of the cup (see Fig. 11).

X1.2 The siphon should be made of 5 mm inside diameter tubing (0.25 in. (6 mm) in outside diameter) and should be bent with a small but uniform radius. The siphon tube should be soldered to the beaker with a stainless steel solder.

X1.3 A stainless steel wire of approximately 0.045 in. (1 mm) in diameter shall be inserted in two opposing holes drilled in the top section of the beaker. The wire length should be adjusted to allow the cup to hang 1 in. (25 mm) below the bottom loop of the condenser coil.

ASTM International takes no position respecting the validity of any patent rights asserted in connection with any item mentioned in this standard. Users of this standard are expressly advised that determination of the validity of any such patent rights, and the risk of infringement of such rights, are entirely their own responsibility.

This standard is subject to revision at any time by the responsible technical committee and must be reviewed every five years and if not revised, either reapproved or withdrawn. Your comments are invited either for revision of this standard or for additional standards and should be addressed to ASTM International Headquarters. Your comments will receive careful consideration at a meeting of the responsible technical committee, which you may attend. If you feel that your comments have not received a fair hearing you should make your views known to the ASTM Committee on Standards, at the address shown below.

This standard is copyrighted by ASTM International, 100 Barr Harbor Drive, PO Box C700, West Conshohocken, PA 19428-2959, United States. Individual reprints (single or multiple copies) of this standard may be obtained by contacting ASTM at the above address or at 610-832-9585 (phone), 610-832-9555 (fax), or service@astm.org (e-mail); or through the ASTM website (www.astm.org).