



Standard Test Method for Thermal Endurance of Flexible Electrical Insulating Varnishes¹

This standard is issued under the fixed designation D 1932; the number immediately following the designation indicates the year of original adoption or, in the case of revision, the year of last revision. A number in parentheses indicates the year of last reapproval. A superscript epsilon (ϵ) indicates an editorial change since the last revision or reapproval.

This standard has been approved for use by agencies of the Department of Defense.

1. Scope

1.1 This test method covers the determination of the relative thermal endurance of flexible electrical insulating varnishes by determining the time necessary at elevated temperatures to decrease the dielectric breakdown of the varnish to an arbitrarily selected value when applied to a standard glass fiber fabric.

1.2 This test method does not apply to varnishes that lose a high percentage of their dielectric breakdown voltage when flexed before elevated temperature exposure as prescribed in the screening test (Section 9). Examples of such varnishes are those used for high speed armatures and laminated structures. Also, this test method is not applicable to varnishes which distort sufficiently during thermal elevated temperature exposure so that they cannot be tested using the curved electrode assembly.

1.3 Thermal endurance is expressed in terms of a temperature index.

1.4 *This standard does not purport to address all of the safety concerns, if any, associated with its use. It is the responsibility of the user of this standard to establish appropriate safety and health practices and determine the applicability of regulatory limitations prior to use.* For specific hazard statements, see Section 7.

1.5 The values stated in SI units are the standard.

NOTE 1—There is no equivalent IEC or ISO standard.

2. Referenced Documents

2.1 ASTM Standards:²

D 149 Test Method for Dielectric Breakdown Voltage and

Dielectric Strength of Solid Electrical Insulating Materials at Commercial Power Frequencies

D 374 Test Methods for Thickness of Solid Electrical Insulation

D 580 Specification for Greige Woven Glass Tapes and Webbing

D 1346 Methods of Testing Electrical Insulating Varnishes for 180°C and Above³

D 1711 Terminology Relating to Electrical Insulation

D 2518 Specification for Woven Glass Fabrics for Electrical Insulation

D 5423 Specification for Forced-Convection Laboratory Ovens for Evaluation of Electrical Insulation

D 6054 Practice for Conditioning Electrical Insulating Materials for Testing

2.2 IEEE Publications:⁴

IEEE No. 101A Guide for the Statistical Analysis of Thermal Life Test Data (including Appendix A)

2.3 IEC Publications:

IEC 60216 Guide for the Determination of Thermal Endurance Properties of Electrical Insulating Materials (Part 1)⁵

3. Terminology

3.1 Definitions:

3.1.1 *temperature index (TI), n*—a number which permits comparison of the temperature/time characteristics of an electrical insulating material, or a simple combination of materials, based on the temperature in degrees Celsius which is obtained by extrapolating the Arrhenius plot of endpoint time versus temperature to a specified time, usually 20 000 h.

3.1.2 *thermal endurance graph, n*—an Arrhenius plot.

3.1.3 *thermal endpoint time, n*—the time necessary for a specific property of a material, or a simple combination of materials, to degrade to a defined end point when aged at a specified temperature.

¹ This test method is under the jurisdiction of ASTM Committee D09 on Electrical and Electronic Insulating Materials and is the direct responsibility of Subcommittee D09.01 on Electrical Insulating Varnishes, Powders, and Encapsulating Compounds.

Current edition approved Oct. 1, 2003. Published October 2003. Originally approved in 1967. Last previous edition approved in 2001 as D 1932 – 01.

² For referenced ASTM standards, visit the ASTM website, www.astm.org, or contact ASTM Customer Service at service@astm.org. For Annual Book of ASTM Standards volume information, refer to the standard's Document Summary page on the ASTM website.

³ Withdrawn.

⁴ Available from the Institute of Electrical and Electronics Engineers, 1828 L St., NW, Suite 1202, Washington, DC 20036–5104.

⁵ Available from American National Standards Institute, 25 West 43rd St., 4th Floor, New York, NY 10036.

3.1.4 *thermal life endpoint time, n*—a graphical representation of thermal endpoint time at a specified exposure temperature in which the value of a property of a material, or a simple combination of materials, is measured at room temperature and the values plotted as a function of time.

3.1.5 Refer to Terminology D 1711 for definitions of other terms.

4. Summary of Test Method

4.1 Specimens are prepared using glass cloth coated with the selected varnish to a specified build.

4.2 Specimens are exposed in air at a minimum of three temperatures above the expected use temperature of the material. Dielectric breakdown voltage tests in air at room temperature are periodically made to determine the exposure time at each test temperature required to reduce the breakdown voltage to a value of 12 kV/mm (300 V/mil) of original thickness. These values are used to construct a thermal endurance graph by which temperature indices may be estimated.

4.3 This test method is not applicable to materials having an initial dielectric breakdown voltage of less than 12 kV/mm (300 V/mil) of original thickness unless lower endpoint values are agreed upon or indicated in the applicable material specifications.

5. Significance and Use

5.1 A major factor affecting the long term performance of insulating materials is thermal degradation. Other factors, such as moisture and vibration, may cause failures after the material has been weakened by thermal degradation.

5.2 An electrical insulating varnish is effective in protecting electrical equipment only as long as it retains its physical and electrical integrity.

5.3 The thermal degradation of the varnish results in weight loss, porosity, crazing, and generally a reduction in flexibility. Degradation of the varnish can be detected by a decrease in

dielectric strength, which is therefore used as the failure criterion for this test method.

5.4 Electrical insulating varnishes undergo flexing in service due to vibration and thermal expansion. For this reason, this functional test includes flexing and elongation of the insulation. The electrodes used in this test method are designed to elongate the outer surface of the specimen 2 % with respect to the neutral axis of the base fiber while being tested for dielectric breakdown.

6. Apparatus

6.1 *Electrode Test Fixture*—The fixture shall be in accordance with the dimensions shown in Fig. 1 and Fig. 2. Electrodes shall be of polished brass, with the upper electrode having a mass of 1.8 ± 0.05 kg (4.0 ± 0.1 lb).

6.2 *Dielectric Breakdown Test Set*—The set shall meet the requirements of Test Method D 149.

6.3 *Ovens*—A forced draft constant-temperature oven conforming to Specification D 5423, Type II.

6.4 *Micrometer*—Dead-weight type specified in Test Methods D 374, having a presser foot 6.35 ± 0.03 mm (0.25 ± 0.001 in.) in diameter and an anvil of at least 50 mm (2 in.) diameter and shall exert a pressure of 0.17 ± 0.01 MPa (25 ± 2 psi) on the pressure foot.

6.5 *Test Specimen Frame*—A frame for each test specimen made from a straight length (approximately 1 m (39 in.)) of round Nichrome AWG No. 14 wire. Bend the wire to form a rectangle having inside dimensions of 150 by 300 mm (6 by 12 in.). Overlap the ends of the wire approximately 50 mm (2 in.) at one corner. Attach the specimen to the frame.

6.6 *Test Fixture for Exposing Specimen to Elevated Temperature*—A suitable fixture for mounting the specimen frames a minimum of 25 mm (1 in.) apart so that they are secured at top and bottom.

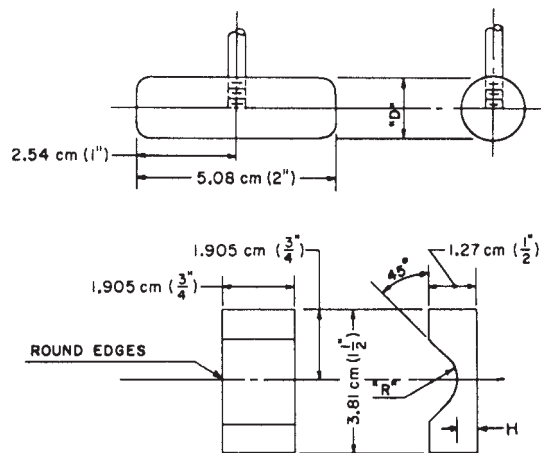

Insulation Thickness		Dimension R		Dimension H		Dimension D	
cm	in.	cm	in.	cm	in.	cm	in.
0.018	0.007	0.455	0.179	0.815	0.321	0.871	0.344

Tolerance for R and D = 0.003 cm (0.001 in.)
 Tolerance for H = 0.005 cm (0.002 in.)

FIG. 1 Single-Shot Curved Electrode Details

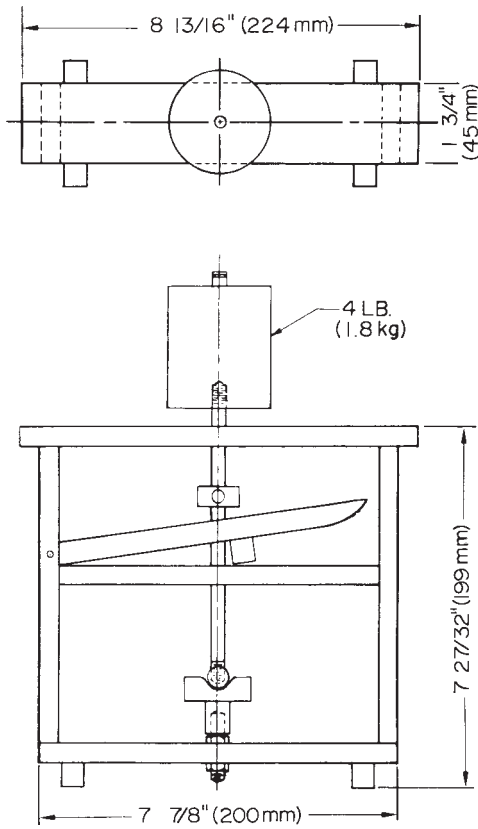

FIG. 2 Curved Electrode and Holder

6.7 *Dipping Apparatus*—An apparatus capable of removing the specimen from the varnish at the rate of approximately 100 mm (4 in.)/min.

7. Safety Precautions

7.1 It is unsafe to use varnish at temperatures above the flash point without adequate ventilation, especially if the possibility exists that flames or sparks are present. Store varnish in sealed containers.

8. Test Specimens

8.1 Prepare glass cloth panels 150 by 300 mm (6 by 12 in.) with the 300 mm (12 in.) dimension parallel to the warp threads. Use fabric style No. 116 in accordance with Specification D 2518. Heat clean the specimens as specified in Methods D 1346 to arrive at a volatile content not to exceed 0.1 % in accordance with Specification D 580.

8.2 Prepare the test specimen by dipping a glass cloth panel described in 8.1 in the varnish at the standard laboratory atmosphere described in Practice D 6054. Prior to dipping panels, adjust the viscosity of the varnish to be tested by trial so that two coats will give an over-all thickness of 0.178 ± 0.0127 mm (0.007 ± 0.0005 in.).

8.3 Immerse the panel in the varnish in the direction of the 300 mm (12 in.) length until bubbling stops, mechanically withdraw at the rate of approximately 100 mm (4 in.)/min, and then allow to drain for $\frac{1}{2}$ h at the standard laboratory atmosphere.

8.4 Bake the specimen in the same vertical position as dipped. Reverse the specimen, dip a second time, and drain as

above. Bake the specimen at such a temperature and for such a time as specified by the varnish manufacturer.

8.5 Prepare a set of twelve or more specimens for each exposure temperature.

9. Screening Test

9.1 Prepare one test specimen. Condition the specimen 48 h in the standard laboratory atmosphere. Cut five 25 by 300 mm (1 by 12 in.) test strips from the center of the specimen, discarding the 12.5 by 300 mm ($\frac{1}{2}$ by 12 in.) portion from each side. Bend each of the five test strips once, 115 mm ($4\frac{1}{2}$ in.) from one end, 180° around a mandrel 3.175 mm (0.125 in.) in diameter.

9.2 Measure the dielectric breakdown voltage on the bent area of each five test strips. In like manner, make five breakdown tests on the unbent area at a distance of 75 mm (3 in.) from the bend. Use the apparatus described in 6.2 in accordance with the procedure described in 11.2, except use 6.4 mm ($\frac{1}{4}$ in.) diameter electrodes as specified in Test Method D 149.

9.3 Average the dielectric breakdown voltage for the five bent and unbent areas respectively. The ratio of average breakdown voltage of the bent area to the unbent area shall be greater than 0.5, if this method is to be considered applicable.

10. Selection of Test Temperatures

10.1 Expose the material to at least three temperatures. Choose the lowest temperature such that it is not more than 25°C higher than the estimated temperature index. Exposure temperatures should differ by at least 10°C and preferably 20°C .

10.2 Select exposure temperatures in accordance with those shown in Table 1 as indicated by the anticipated temperature index of the material under test. It is recommended that exploratory tests be first made at the highest temperature to obtain data establishing the validity of the 100 h minimum endpoint time requirement and that this be used as a guide for the selection of the lower test temperatures.

11. Procedure

11.1 *Thickness Measurement*—Measure the average thickness of one representative specimen from each set at five points along its center before heat exposure. Determine the thickness along the center of the specimen parallel to its 300 mm (12 in.) length using the apparatus described in 6.4 and Test Methods D 374. Allow the presser foot to remain on the test specimen for 2 s before taking a reading.

11.2 *Dielectric Breakdown Voltage (Initial)*—Condition one specimen from each set of specimens for at least 48 h in the standard laboratory atmosphere for dielectric breakdown voltage by the short-time method, using a rate of rise of 500 V/s. Make six dielectric breakdown measurements, 45 mm ($1\frac{3}{4}$ in.) apart and starting 40 mm ($1\frac{1}{2}$ in.) from one end of the specimen. Insert the specimen in the curved electrode fixture (Fig. 2) so that the warp threads are bent. Lower the electrode slowly on the specimen.

11.3 *Exposure and Testing of the Specimens*—Tag five specimens with aluminum foil or otherwise permanently identify them, and place in the test fixture described in 6.5. Place

TABLE 1 Suggested Exposure Temperatures and Cycle Durations^A

 Temperatures Corresponding to the Estimated Temperature Index Range, °C,^{B,C}

Cycle Duration, days	Class 105			Class 130			Class 155			Class 180		Class 200		Class 220
	100 to 109	110 to 119	120 to 129	130 to 139	140 to 149	150 to 159	160 to 169	170 to 179	180 to 189	190 to 199	200 to 209	210 to 219	220 to 229	230 to 239
1	170	180	190	200	210	220	230	240	250	260	270	280	290	300
2	160	170	180	190	200	210	220	230	240	250	260	270	280	290
4	150	160	170	180	190	200	210	220	230	240	250	260	270	280
7	140	150	160	170	180	190	200	210	220	230	240	250	260	270
14	130	140	150	160	170	180	190	200	210	220	230	240	250	260
28	120	130	140	150	160	170	180	190	200	210	220	230	240	250
49	110	120	130	140	150	160	170	180	190	200	210	220	230	240

^A Taken from IEC Publication 60216-1.

^B Exposure temperatures above and below those given are to be selected by experimentation.

^C Range to which the temperature is assumed to correspond to an extrapolated 20 000 h time to failure.

the fixture containing the specimens in the oven which has previously been brought up to the highest selected temperature and positioned so that it is at least 100 mm (4 in.) from the walls at any point. Remove one specimen at each of three time intervals equivalent approximately to 25, 50, and 100 % of the estimated insulation endpoint time at the selected temperature. Immediately after removal, condition the specimen for 4 h in the standard laboratory atmosphere and test for dielectric breakdown voltage in the standard laboratory atmosphere as specified in 11.2.

11.3.1 At the time of 50 % of estimated endpoint time, tag five additional specimens and place them in the test fixture in the oven. Similarly, at the time of 75 % of estimated endpoint time, place the remaining specimens in the oven.

11.3.2 Plot the average dielectric breakdown voltage of each specimen as the ordinate corresponding to exposure time as the abscissa. If endpoint time has been underestimated, remove one specimen of the first group remaining in the oven at 150 % of the estimated insulation endpoint time and test it as previously described.

11.3.3 With information now available on the exposed specimens, remove each of the remaining specimens at intervals so as to establish a curve of average dielectric breakdown voltage versus exposure time. Fill in between available points or extend beyond if necessary. Continue the oven exposure until an average dielectric strength of 8 kV/mm (200 V/mil) (based on original average thickness) is reached or oven exposure has progressed to 10 000 h. Using this information, repeat the same procedure, using at least two other selected exposure temperatures.

12. Calculation

12.1 Establish for each temperature the thermal endpoint curve best fitting the plot of average dielectric breakdown voltage in kilovolts versus the exposure time in hours. Determine from this curve the number of hours corresponding to an end point of 12 kV/mm (300 V/mil) of original thickness. This is the thermal endpoint time at that temperature. End points other than 12 kV/mm (300 V/mil) may be used as specified.

12.2 Where the experimental points are scattered, making accurate fitting difficult, use the mathematical fitting method of least squares. Caution is suggested, however, since some materials exhibit maxima in the breakdown voltage curve due

to further curing during heat exposure and erroneous results may be obtained using analytical methods unless there is a knowledgeable preselection of data points to be used. Since interest lies mainly in the later part of the thermal endpoint curve which includes the end point, selection of experimental data in this vicinity may make possible the use of simple mathematical expressions available in most treatises on empirical curve fitting.

12.3 Significant curvature in the thermal endurance graph indicates the possibility of deterioration due to other than a single chemical reaction mechanism. Curvature should be confirmed by tests at one or more additional exposure temperatures.

12.4 In order to calculate the temperature index, data must be available from a minimum of three aging temperatures. The thermal life at the highest aging temperature must be at least 100 h; and the lowest aging temperature must be at least 5000 h.

12.5 Plot the thermal life at each exposure temperature on graph paper having as the ordinate a logarithmic time scale and as an abscissa a scale arranged according to the reciprocal of the absolute temperature. In the absence of significant curvature of the data, draw a straight line best fitting the plotted data, continuing this line by extrapolation through the abscissa corresponding to a time limit as specified. Alternatively, construct a line using the regression analysis technique outlined in IEEE No. 101A.

12.6 Using IEEE No. 101A, compute the 95 % lower confidence limit at the time ordinate specified expressing this limit in degrees Celsius.

12.7 Determine the temperature index as the temperature in degrees Celsius at which the extrapolated line crosses 20 000 hours.

13. Report

13.1 Report the following information:

13.1.1 Description of the varnish,

13.1.2 Oven time and temperature used to prepare the specimens,

13.1.3 Average thickness of the representative specimens from each set,

13.1.4 Average dielectric breakdown voltage for each exposure period,

13.1.5 End point in kV/mm (V/mil) for original thickness if other than that specified in 11.1,

13.1.6 A thermal endpoint curve for each temperature including the results of dielectric breakdown voltage tests for the initial set of specimens,

13.1.7 The thermal endurance graph on a logarithmic scale as a function of the reciprocal of the absolute temperature (Arrhenius plot),

13.1.8 The temperature index of the material in degrees Celsius corresponding to a endpoint time of 20 000 h or as otherwise agreed upon, and

13.1.9 The lower 95 % confidence limit in degrees Celsius corresponding to the endpoint time as specified.

14. Precision and Bias

14.1 *Precision*—This test method has been in use for many years, but no statement of precision has been made and no activity is planned to develop such a statement.

14.2 *Bias*—This test method has no bias because the value for thermal endurance of flexible insulating varnishes is defined solely in terms of this test method.

15. Keywords

15.1 dielectric strength; glass fiber fabric; thermal endurance; varnish

ASTM International takes no position respecting the validity of any patent rights asserted in connection with any item mentioned in this standard. Users of this standard are expressly advised that determination of the validity of any such patent rights, and the risk of infringement of such rights, are entirely their own responsibility.

This standard is subject to revision at any time by the responsible technical committee and must be reviewed every five years and if not revised, either reapproved or withdrawn. Your comments are invited either for revision of this standard or for additional standards and should be addressed to ASTM International Headquarters. Your comments will receive careful consideration at a meeting of the responsible technical committee, which you may attend. If you feel that your comments have not received a fair hearing you should make your views known to the ASTM Committee on Standards, at the address shown below.

This standard is copyrighted by ASTM International, 100 Barr Harbor Drive, PO Box C700, West Conshohocken, PA 19428-2959, United States. Individual reprints (single or multiple copies) of this standard may be obtained by contacting ASTM at the above address or at 610-832-9585 (phone), 610-832-9555 (fax), or service@astm.org (e-mail); or through the ASTM website (www.astm.org).