



# Standard Test Methods for Liquid-Contaminant, Inclined-Plane Tracking and Erosion of Insulating Materials<sup>1</sup>

This standard is issued under the fixed designation D 2303; the number immediately following the designation indicates the year of original adoption or, in the case of revision, the year of last revision. A number in parentheses indicates the year of last reapproval. A superscript epsilon ( $\epsilon$ ) indicates an editorial change since the last revision or reapproval.

*This standard has been approved for use by agencies of the Department of Defense.*

## 1. Scope

1.1 These test methods cover the evaluation of the relative tracking and erosion resistance of insulating solids using the liquid-contaminant, inclined-plane test.<sup>2</sup> The following test methods also can be used to evaluate the tracking resistance of materials: D 2132 (contaminants: dust and fog) and D 3638 (contaminant: conductive liquid drops).

1.2 Two tracking and one erosion test procedure are described:

1.2.1 A “variable voltage method” to evaluate resistance to tracking.

1.2.2 A “time-to-track method” to evaluate resistance to tracking.

1.2.3 A method for quantitative determination of erosion (Annex A1).

1.3 While a particular contaminant solution is specified, other concentrations of the same contaminant, or different contaminants may be used to simulate different environmental or service conditions.

1.4 The values stated in inch-pound units are to be regarded as the standard.

1.5 *This standard does not purport to address all of the safety concerns, if any, associated with its use. It is the responsibility of the user of this standard to establish appropriate safety and health practices and determine the applicability of regulatory limitations prior to use.* Specific precautionary statements are given in Section 8.

## 2. Referenced Documents

### 2.1 ASTM Standards:

D 374 Test Methods for Thickness of Solid Electrical Insulation<sup>3</sup>

D 1711 Terminology Relating to Electrical Insulation<sup>3</sup>

D 2132 Test Method for Dust- and Fog-Tracking and Erosion Resistance of Electrical Insulating Materials<sup>3</sup>

D 3638 Test Method for Comparative Tracking Index of Electrical Insulating Materials<sup>4</sup>

## 3. Terminology

### 3.1 Definitions:

3.1.1 *erosion, electrical, n*—the progressive wearing away of electrical insulation by the action of electrical discharges.

3.1.2 *erosion resistance, electrical, n*—the quantitative expression of the amount of electrical erosion under specific conditions.

3.1.3 *track, n*—a partially conducting path of localized deterioration on the surface of an insulating material.

3.1.4 *tracking, n*—the process that produces tracks as a result of the action of electric discharges on or close to the insulation surface.

3.1.5 *tracking, contamination, n*—tracking caused by scintillations that result from the increased surface conduction due to contamination.

3.1.6 *tracking resistance, n*—the quantitative expression of the voltage and the time required to develop a track under specified conditions.

### 3.2 Definitions of Terms Specific to This Standard:

3.2.1 *initial tracking voltage, n*—the applied voltage at which continuous tracking can be initiated in a specified time.

3.2.2 *time-to-track, n*—the time in which tracking proceeds a specified distance between the test electrodes at a specified voltage.

3.3 Other definitions pertinent to these test methods are given in Terminology D 1711.

## 4. Significance and Use

4.1 These test methods differentiate among solid electrical insulating materials on the basis of their resistance to the action of voltage stresses along the surface of the solid when wet with an ionizable, electrically conductive, liquid contaminant.

4.2 These test methods quantitatively evaluate, in a relative manner, the effects upon an insulating material resulting from

<sup>1</sup> These test methods are under the jurisdiction of ASTM Committee D-9 on Electrical and Electronic Insulating Materials and are the direct responsibility of Subcommittee D09.12 on Electrical and Electronic Tests.

Current edition approved Sept. 10, 1997. Published November 1997. Originally issued as D 2303 – 64 T. Last previous edition D 2303 – 96.

<sup>2</sup> K. N. Mathes, Chapter 4, “Surface Failure Measurements,” *Engineering Dielectrics, Vol IIB, Electrical Properties of Solid Insulating Materials, Measurement Techniques*, R. Bartnikas, Editor, ASTM STP 926, ASTM, Philadelphia, 1987.

<sup>3</sup> *Annual Book of ASTM Standards*, Vol 10.01.

<sup>4</sup> *Annual Book of ASTM Standards*, Vol 10.02.

the action of electrical discharges upon a material surface. The effects are similar to those that may occur in service under the influence of dirt combined with moisture condensed from the atmosphere.

4.2.1 In the field, the conditions resulting in electrical discharges occur sporadically. Degradation, often in the form of a conducting "track", develops very slowly until it ultimately bridges the space between conductors thus causing complete electrical breakdown.

4.2.2 In these test methods, the conducting liquid contaminant is continuously supplied at an optimum rate to the surface of a test specimen in such a fashion that essentially continuous electrical discharge can be maintained.

4.2.3 By producing continuous surface discharge with controlled energy it is possible, within a few hours, to cause specimen failure which is similar to failure occurring under long-time exposure to the erratic conditions of service in the field.

4.2.4 The test conditions, which are standardized and accelerated, do not reproduce all of the conditions encountered in service. Use caution when making either direct or comparative service behavior inferences derived from the results of tracking tests.

4.3 The time-to-track a 1-in. (25-mm) distance at a specified voltage between electrodes separated 2 in. (50 mm) has also been found useful in categorizing insulating materials for indoor and protected outdoor applications, such as metal-clad switchgear.

4.4 The initial tracking voltage has been found useful for evaluating insulating materials to be used at high voltages or outdoors and unprotected, as well as for establishing (see 10.1) the test voltage for the time-to-track test.

4.5 In service many types of contamination may cause tracking and erosion of different materials to different degrees. This method recognizes the importance of such variability and suggests the use of special test solutions to meet specific service needs. For example, an ionic contaminant containing, in addition, a carbonaceous component such as sugar may be used to cause tracking on very resistant materials like polymethylmethacrylate. Such contamination may be representative of some severe industrial environments. In this case, the time-to-track technique is used, since time is required to decompose the contaminant solution and build up conducting residues on the sample surface.

4.6 Very track-resistant materials, such as polymethylmethacrylate, may erode rather than track under more usual contaminant conditions in service. The use of this method for measuring erosion is consequently important. For erosion studies, only tests as a function of time at constant voltage are useful.

### 5. Apparatus

5.1 A simple schematic diagram of the apparatus is given in Fig. 1 and consists of the following. Details are given in Annex A2.

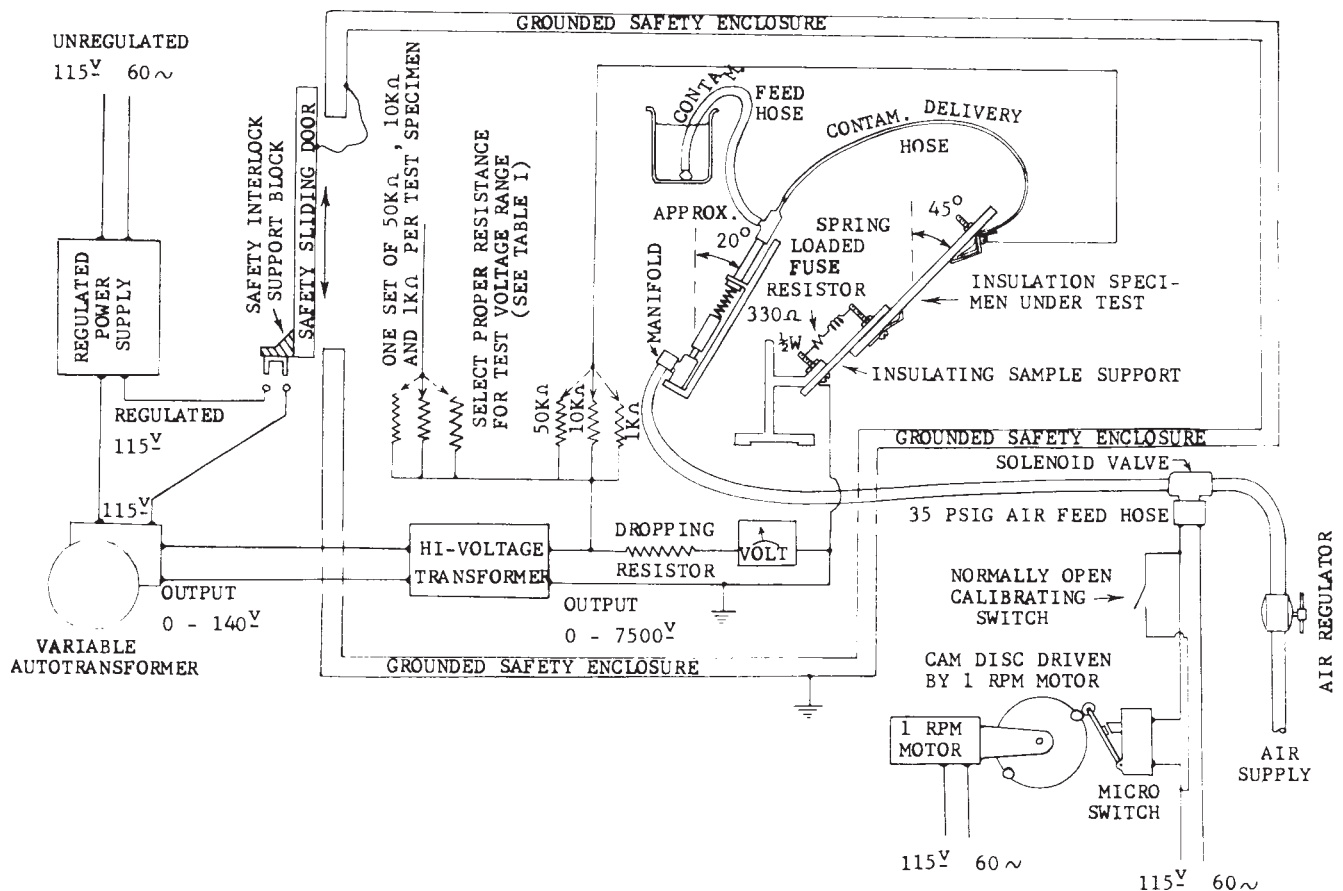

FIG. 1 Schematic Diagram of Apparatus

5.1.1 A 60-Hz power supply with an output voltage stabilized to  $\pm 1\%$  which can be varied from 1 to at least 7.5 kV with a rated current of no less than 0.1 A for every test station to be used (that is, 0.5 A for five stations).

5.1.2 A means for applying a specified contaminant solution at a controlled rate to the specimen surface. A pneumatically actuated repeating pipet has been found useful for this purpose and is described in Annex A2. Peristaltic pumps have also been used (A2).

5.1.3 Stainless steel top and bottom electrodes as shown in Fig. 2.

5.1.6 A 330- $\Omega$ , 1/2-W, carbon resistor<sup>5</sup> mounted with a simple tension spring and connected in series with the specimen and ground to act as an overload, high-voltage fuse.

5.1.7 Structural parts and a grounded safety enclosure.

6. Sampling

6.1 Refer to applicable materials specifications for sampling instructions.

7. Test Specimens

7.1 Make insulation specimens with a flat surface approxi-

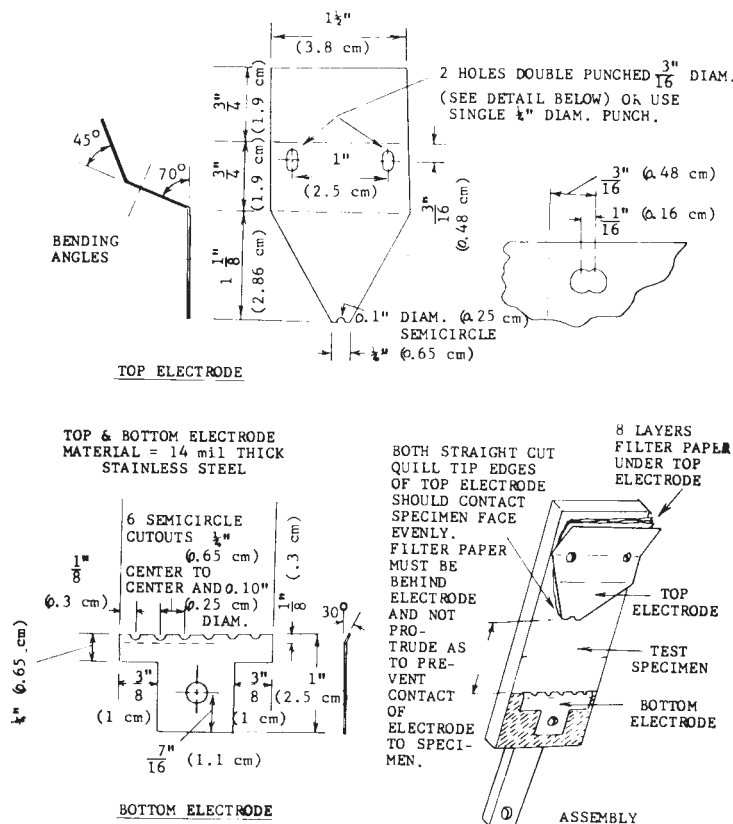

FIG. 2 Top and Bottom Electrodes

NOTE 1—Stainless-steel type 302 is recommended.

5.1.4 A pad of filter paper cut as shown in Fig. 3 to fit under the top electrode and used to smooth out the flow of the contaminant solution.

5.1.5 A set of ballast resistors (50, 10, and 1-k $\Omega$  rated at 200 W each) to be connected as specified in series with each test specimen on the high-voltage side of the power supply. Somewhat lower resistances are being considered by the International Electrotechnical Commission (IEC/TC15).

mately 2 by 5 in. (50 by 130 mm) as shown in Fig. 4. Measure the thickness in accordance with Test Methods D 374 if there is no standard for a particular material. Specimens must be thick enough that tracking does not penetrate completely through the specimen during the test. Secure thin specimens to prevent sagging. Specimens thicker than 3/4 in. (2 cm) are difficult to clamp in the apparatus.

7.2 Prepare separate specimens exposing each surface of sheet or other materials with two or more surfaces which may have different characteristics. Carefully identify the surface so

<sup>5</sup> International Resistance Co. RC 20-mil type carbon-composition resistors, available from the TRW Electronics Corp., Commerce Terminal Bldg., Philadelphia, PA, have been found satisfactory.

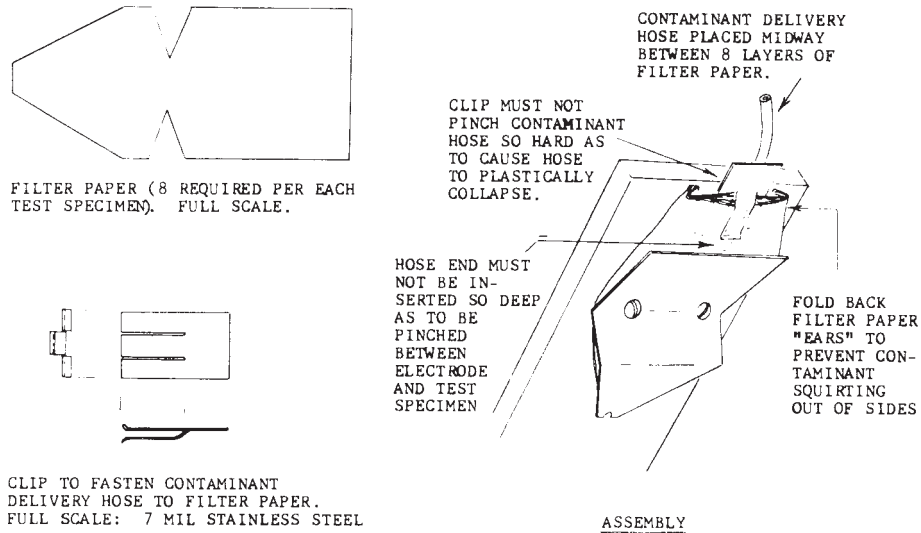

FIG. 3 Filter Paper, Showing Clip and Method of Fastening

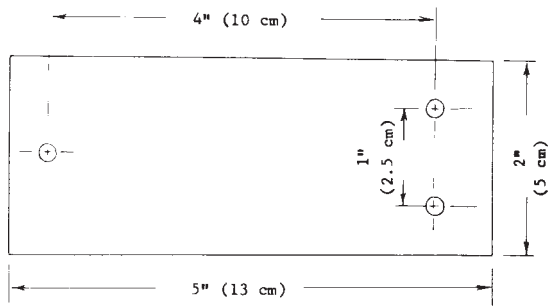

FIG. 4 Test Specimen

far as possible, that is, mold face, press face, etc. Prepare two sets of specimens of materials with noticeable directional characteristics, with the predominant directional characteristic in line with the electrodes for one set and at right angles to the other set. Identify the specimen direction as far as possible; that is, machine direction, cross-machine direction, warp or fill direction (for woven textile reinforced products). Fig. 5

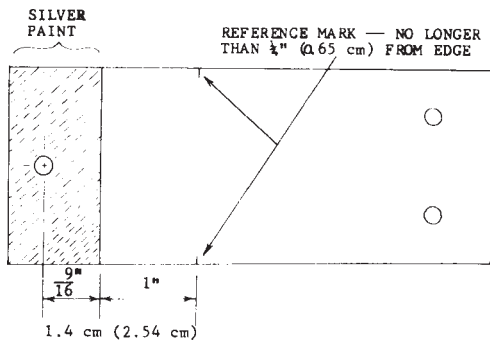

FIG. 5 Test Specimen Showing Location of Conducting Silver Paint and Tracking Reference Marks

7.3 *Preparation of Specimens*—Clean the specimen face with a suitable solvent<sup>6</sup> and rinse with distilled water. For specimens to be used in the time-to-track method, do not mechanically destroy, that is, sand, abrade, etc. the natural surface finish of the specimen unless otherwise specified. However, with the variable-voltage method, the surface of the test specimens should be lightly but completely sanded under flowing tap water with 400A-grit wet silicon carbide paper and rinsed with distilled water. Such sanding removes gloss and contaminants to provide a surface that is wet more easily and rapidly by the contaminant. Loss of gloss and slight erosion of the surface usually occurs in service, particularly outdoors. Generously cover the specimen area under the bottom electrode with conductive silver paint<sup>7</sup> and add the 1-in. (25-mm) tracking reference marks as shown in Fig. 5. For all tests, other than the time-to-track test, soak the test specimens prepared as above for 24 to 48 h in the specified contaminant solution before test.

7.4 Prepare five specimens for each determination.

## 8. Procedure

8.1 *Lethal voltages are a potential hazard during the performance of this test. It is essential that the test apparatus, and all associated equipment electrically connected to it, be properly designed and installed for safe operation. Solidly ground all electrically conductive parts which it is possible for a person to contact during the test. Provide means for use at the completion of any test to ground any parts which were at high voltage during the test or have the potential for acquiring an induced charge during the test or retaining a charge even after disconnection of the voltage source. Thoroughly instruct*

<sup>6</sup> The solvent should not soften or otherwise damage the test specimen. Isopropyl alcohol has been found suitable for many materials.

<sup>7</sup> DuPont silver paint No. 4817 has been found suitable for this purpose.

all operators as to the correct procedures for performing tests safely. When making high voltage tests, particularly in compressed gas or in oil, it is possible for the energy released at breakdown to be sufficient to result in fire, explosion, or rupture of the test chamber. Design test equipment, test chambers, and test specimens so as to minimize the possibility of such occurrences and to eliminate the possibility of personal injury. If the potential for fire exists, have fire suppression equipment available.

8.1.1 Also see Fig. 1.

**TABLE 1 Rates of Contaminant Application**

NOTE 1—The rates of contaminant application shown are suitable only for contaminants with a resistivity of approximately 370 to 400  $\Omega$ -cm at 23°C on nonporous samples. With porous samples it may be necessary to increase the contaminant flow somewhat to maintain effective, continual scintillation. Lower contaminant resistivities also will require a higher rate and higher resistivities, a lower rate of contaminant application; this must be determined experimentally. At too high a contaminant rate scintillation will be greatly reduced because the current will flow in the contaminant film without disrupting it. At too low a rate the solution boils away or at the higher voltages is electrostatically removed so that scintillation occurs only at intervals in scattered bursts.<sup>A</sup> The tendency for tracking and erosion is increased with a decrease in contaminant resistivity or with the incorporation of a carbonaceous material such as sugar, even though in the latter case the resistivity is not decreased. The chemical nature of the ionizable contaminant is usually of minor importance in respect to tracking but may be of major importance in respect to erosion.

Rate of Application of 0.1 % $\text{NH}_4\text{Cl}$ -0.02 % Wetting Agent, mL/min	Voltage Range, kV	Series Resistor, $\Omega$
0.075	1.0 <sup>B</sup> to 1.75	1 000
0.15	2.0 to 2.75	10 000
0.30	3.0 to 3.75	50 000
0.60	4.0 to 4.75	50 000
0.90	5.0 to 6.0	50 000

<sup>A</sup> Mathes, K. N., and McGowan, E. J., "Surface Electrical Failure in the Presence of Contaminants. The Inclined-Plane, Liquid-Contaminant Test," *Transactions, Part I, Communications and Electronics*, Am. Inst. Electrical Engrs., TEECA, July, 1961 (AIEE Preprint 61-21).

<sup>B</sup> Scintillation at 1 kV is very critical, and it may be desirable to remove the series resistor and to decrease further the contaminant rate, that is, so that 0.075 mL is applied only once every 2 min. With such slow rates, it is possible also to obtain scintillation at voltages even lower than 1 kV to permit test of relatively poor materials.

8.2 Mount and fuse the specimen with the flat test surface on the underside at an angle of 45° from the horizontal as shown in Fig. 1. Insert the contaminant delivery hose midway between eight thicknesses of the filter paper as shown in Fig. 3(c) and fold back the filter paper "ear" to prevent contaminant from squirting out the sides.

8.3 At the start of each test date, replace all residual liquid in the contaminant supply beaker with fresh contaminant. Cover all beakers to minimize dust and dirt as well as evaporation. Unless otherwise specified, use 0.1 % (by weight) ammonium chloride (reagent grade) and 0.02 % nonionic wetting agent<sup>8</sup> in distilled water. This contaminant solution

<sup>8</sup> Triton X-100 made by Rohm and Haas Co., Philadelphia, PA, has been found satisfactory. It should be added to a small portion of the water and thoroughly mixed before being added to the larger bulk.

must have a resistivity between 370 and 400  $\Omega$ -cm when measured at 23 ± 1°C.

8.4 Adjust the contaminant flow and calibrate as described in Annex A1 to give the flow rate for the voltage to be specified in Table 1.

8.5 After calibration, the start-up procedure differs, depending on whether the test specimen is a carry-over from a previous test, or an entirely new specimen.

8.5.1 For a specimen that has never been subjected to voltages and contaminant (that is, new specimen), start the contaminant injection into the filter paper, allowing the fresh contaminant to wet the filter paper thoroughly and replace the old liquid in the tubes and syringes and to flow as a steady stream (Note 2) (not intermittent bursts) across the test specimen face between electrodes. The contaminant must flow from the quill hole in the bottom of the top electrode and should not squirt out of the sides or top of the filter paper during the pressure stroke of the pipet. Adjust the specimens so that the contaminant runs down as nearly as possible the center line of the specimen. Avoid drafts on equipment that might cause undue cooling of the specimens or of the water vapor from evaporation of the contaminant. Close the safety gate and apply the appropriate test voltage tabulated in Table 1.

NOTE 2—This steady flow condition should be observed for 5 min at the normal test contaminant feed rate and not at a manually operated accelerated calibration rate.

8.5.2 For a specimen that is a continuation from a previous test (that is, off test overnight), wash down the test specimen face and filter paper with distilled water in order to remove any contaminant residue from the previous test. Do not change the filter paper. Start the contaminant flow, allowing the fresh contaminant to wet the filter paper thoroughly, and replace the old liquid in the tubes and syringes until a steady contaminant flow (Note 2) is established across the specimen face. Momentarily arrest the contaminant injection into the filter paper, and inject 2 mL of distilled water into the filter paper with a manual syringe. Quickly rewash the specimen face only with distilled water, close the safety gate, start up the contaminant flow, and apply the required voltage. Time is of the essence here, for any prolonged delay will result in a too vigorous and faulty start-up.

8.6 Effective scintillation, small yellow to white (perhaps with some parts blue) arcs, should appear predominantly just above the teeth of the lower electrode within at most a very few minutes after application of the voltage. These discharges should occur in essentially continuous fashion, although they may "dance" from one tooth to another before finally settling down to cause a small, bright "hot spot" which will start "chewing" on the specimen surface and which will ultimately lead to tracking failure. The condition of effective scintillation can also be observed with a cathode-ray oscilloscope. The signal may be picked off the ungrounded side of the fuse resistor. Proper scintillation is observed as a continual but nonuniform break-up of the 60-Hz current wave over the whole duration of each half cycle. Effective scintillation is critical and if not obtained, then the electrical circuit, the contaminant flow characteristics, and the contaminant conductivity must be carefully checked and adjusted if necessary.

8.7 Regardless of whether the start-up is for new or old specimens, watch the scintillations for the first 15 min, and periodically at least once every hour thereafter. Thus, the tracking time can be noted, in addition to watching for:

8.7.1 Steady scintillation between successive injections,

8.7.2 Loss of any contaminant, such as by squirting out of side of filter paper,

8.7.3 Whether the contaminant stream down the test specimen face is steady instead of in spurts,

8.7.4 Air bubble leaks into the syringes which would change the contaminant feed rate, and

8.7.5 Stuck syringe pistons.

8.8 Note the time, but do not stop the test to disconnect, any test specimen that has tracked to the 1-in. mark. Stopping the test and removing the voltage, even momentarily, will permit the contaminant to saturate excessively the partially tracked area of other unfailed specimens, with resultant vigorous scintillation after restart. Excessive current in any specimen that continues to track will be taken care of by the fuse resistor.

8.9 If the test is not completed within the working day, the test can be continued the following day if the following precautions are taken:

8.9.1 Remove voltage, and stop the contaminant feed.

8.9.2 Thoroughly wash down the filter paper with distilled water. Do not replace the filter paper.

8.9.3 Thoroughly wash down the specimen face with distilled water.

8.9.4 Throw out the contaminant left in the supply beaker and replace with distilled water so that the feed hose sinker will not become encrusted with dried contaminant residue. Do not pump this distilled water into the hose, filter paper, or syringe.

8.10 The method of voltage application and the evaluation of tracking or erosion characteristics depend upon the different test techniques used as described in Sections 9-11 and Annex A1.

## 9. Initial Tracking Voltage Test Method

9.1 For the determination of the initial tracking voltage, apply the voltage between the electrodes in 250-V steps. Hold each voltage for 1 h (unless failure is indicated) before increasing by 250 V to the next step. A starting test voltage must be determined so that tracking failure does not occur sooner than the third step (between 2 and 3 h). Adjust the rate of contaminant application so as to maintain effective scintillation at the different voltages (see Table 1). Time can be saved in the determination of the appropriate starting test voltage for a specific material if an intermediate to high voltage is first selected (that is, 3.25 kV). If the specimen fails quickly on the first voltage step, the starting voltage for the next test should be decreased, usually at least 1 kV. On the other hand, if four steps or more are needed to cause failure, then the initial voltage may be increased accordingly. Experience helps in the determination of the appropriate starting voltage.

9.2 The end point of the test is reached at the voltage step where progressive tracking starts. Careful observation is needed to note when isolated markings on the surface first join together and start progressing upward from the bottom electrode. It is important to let this track proceed at least ½ in. (13 mm) up the specimen surface before discontinuing the test to

make certain that progressive tracking is actually under way. (Some test specimens appear to start tracking and then “clean up.”) Record the voltage at which continuous tracking is established as the “initial tracking voltage.” The elapsed time in the voltage step at which progressive tracking starts should be recorded but is not considered to be as significant as the value of the voltage.

9.3 Observe and record the character of the track and the appearance of the test specimen at the end of test. Tracking may be, for example, broad, narrow, filamentary, or dendritic (tree-like), with or without deep erosion. The track may be black, brown, or sometimes even white, and may perhaps occur along fiber bundles in the material. The residue in the track may be hard, tough, brittle, powdery, fluffy, etc. The specimen itself in the presence of the contaminant and scintillation may change color, the weave in fabric reinforcement may become more pronounced, delamination may be apparent, etc.

9.4 Maintain the contaminant feed rate constant throughout the test. Calibrate the rate (see Annex A2) at the beginning and end of each test day, or more often if the rate appears to be variable. A feed rate constancy of less than  $\pm 5\%$  (preferably  $\pm 1\%$ ) is desirable for the duration of track testing of a specimen.

## 10. Time-to-Track Test Method

10.1 For the time-to-track technique, a constant, specified test voltage (Note 3) is used and the tracking time is recorded. If the test voltage is not specified, a voltage 750 V lower than the initial tracking voltage as determined in Section 9 may be used. All materials in a tracking class must, of course, be tested at the same voltage. The requirements of Table 1 must be met for the test voltage used.

NOTE 3—A test voltage of 2.5 kV has been found generally useful for many track-resistant materials of ¼-in. (6.5-mm) thickness. For poor tracking materials and thicknesses to ⅛ in. (1.5 mm), preliminary evaluations indicate promise for the use of 1.5 kV with no series resistor. For less than 2.0 kV, scintillation is difficult to maintain. The maximum useful voltage is 6 kV. Precautions should be taken for over 5-kV voltages.

10.2 Since relatively long tracking time may result (as much as 10 + h), it is important to ensure that the contaminant feed rate remains constant over the total test period. Calibrate the rate (see Annex A2) both before the start and at the end of each test or at least at the beginning and end of each day.

10.3 The time to track a distance of 1 in. (25.4 mm) above the lower electrode (to the reference mark of Fig. 2) is taken as the failure criterion and should be reported in hours and minutes. A taut horizontal string within the test enclosure can be used as a sighting reference to judge whether tracking has progressed to the reference marks. If the time to track is less than 10 min or more than about 15 h, it may be assumed that the material is out of the voltage class, and a lower or higher test voltage should be selected if evaluation is required in this case.

10.4 Failure time for the total 2-in. (50-mm) distance between electrodes (instead of the 25.4-mm test distance) is not representative of the track resistance of the material, since the last ¼ to ½ in. (65 to 125 mm) of the gap (depending on the material) is failed by burning and arcing more so than by tracking.

10.5 Observe the character of the track and report it together with the description of the test specimen as described in 9.3.

**11. Report**

11.1 Report the following information:

11.1.1 Type and designation of material tested,

11.1.2 Details of specimen fabrication including size, thickness, cleaning procedure and solvent used, surface finishing, if any, preconditioning, etc.,

11.1.3 Orientation of the specimen in respect to electrodes (that is, machine-direction, cross-machine direction, warp direction, fill direction, etc.),

11.1.4 Contaminant composition, concentration, conductivity, and temperature of liquid during conductivity measurement, and

11.1.5 Test voltage or voltages and the associated rate of contaminant application.

11.2 In addition, report the following for the specific tests:

11.2.1 *For Initial Tracking Voltage Test:*

11.2.1.1 Initial tracking voltage for each specimen as well as the number of voltage steps used including the final step at which continuous tracking occurred,

11.2.1.2 Time to progressive tracking (9.2) during the last voltage step, and

11.2.1.3 Appearance of the test specimen and the track, including a notation as to the qualitative degree of erosion.

11.2.2 *For Time-to-Track Test:*

11.2.2.1 Value of the test voltage,

11.2.2.2 Time-to-track, in hours and minutes,

11.2.2.3 Appearance of the test specimen and the track, including a notation as to the qualitative degree of accompanying erosion, and

11.2.2.4 Rate of contaminant application at the beginning as well as the end of each test date.

**12. Precision and Bias**

12.1 The coefficient of variation, for tests on the same material in a single laboratory is estimated to range from 20 to 27 %. This estimate is based upon the evaluation of 10 specimens of a glass-reinforced laminate. From a sample of the laminate, 120 specimens were prepared. Twelve laboratories tested 10 specimens taken from the 120.

12.2 A statement of bias cannot be made since a standard reference material of known tracking or erosion resistance is not currently available.

**13. Keywords**

13.1 erosion; electrical; erosion resistance; inclined-plane; liquid contaminant; surface arcing; surface tracking; time-to-track method; track; tracking; tracking resistance; tracking voltage; voltage method; wet tracking

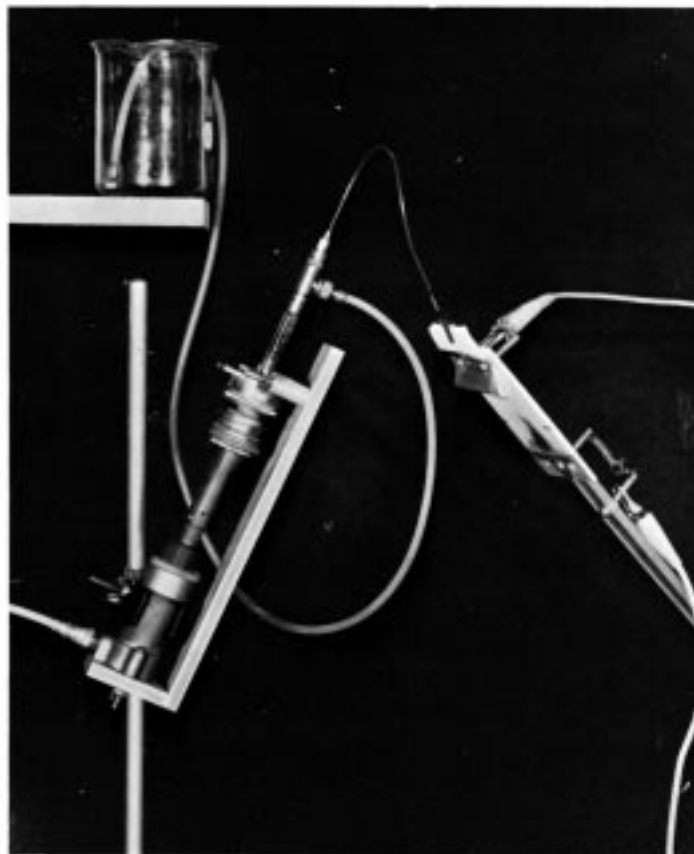

FIG. 6 Assembled Display of One Test Specimen

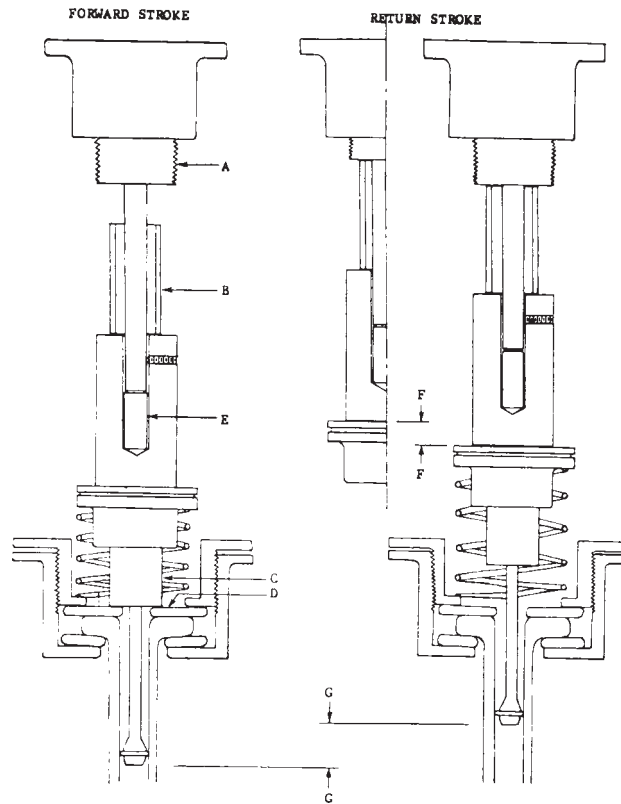

FIG. 7 Method of Operation of Pipet Assembly

## ANNEXES

### (Mandatory Information)

#### A1. EROSION TEST METHOD

A1.1 For erosion studies a constant voltage as described in Section 10 is used. This value (2 kV) is below the value to cause progressive tracking. The test specimen must be at least ¼ in. (6.5 mm) and preferably at least ½ in. (13 mm) thick. Erosion may be measured as a function of time of voltage application or after a specified time such as 24 h. Erosion occurs as a single hole or as multiple holes usually just above one or more of the teeth of the bottom electrode. The eroded hole may contain more or less decomposed residue from the specimen or may be completely free of any residue (that is, polymethylmethacrylate or polytetrafluoroethylene).

A1.2 While 0.1 % NH<sub>4</sub>Cl contaminated solution may be used, it must be recognized that the nature of the contaminant is important with specific materials (that is, sodium nitrate, sodium carbonate, and sodium hydroxide all cause much more erosion of materials like polyester resins and even polytetrafluoroethylene than ammonium chloride does). Consequently, the nature of the contamination expected in service or the particular susceptibility of the test material should be considered in the selection of the contaminant. If the resistivity of the contaminant solution is held between 370 and 400Ω·cm

the values given in Table 1 for effective scintillation usually hold. However, an increase in contaminant conductivity or the addition of a carbonaceous material like sugar will increase the degree of erosion and in some cases, the tendency to erode rather than to track. In such cases, as noted in Table 1, it is necessary to increase the rate of contaminant application so that effective scintillation occurs at the test voltage. For erosion, relatively long test times, such as 24 or 48 h, may be used. In such cases, it is particularly important that the rate of contaminant application hold constant over the total test period. The rate should be calibrated (see Annex A2) both before the start and at the end of the test.

A1.3 To measure erosion quantitatively, it is necessary to remove carefully and mechanically any decomposed residue in the hole or holes. A dial micrometer depth-gage with a 0.0625-in. (3-mm) sensing rod having a 1-in. (25-mm) long taper ending at a point radiused to 0.010 in. (0.25 mm) is used. The difference in reading between uneroded and the maximum reading in the eroded areas is taken as the maximum eroded depth. In the case of multiple holes, the maximum eroded depth in each major hole may be reported. To measure the eroded

volume, a plastic compound<sup>9</sup> that has high coherence and low adhesion to the specimen may be used. Gently press or mechanically work the plastic compound into the eroded holes. Remove excess compound level with the surface of the uneroded specimen by scraping the surface carefully with a doctor bar such as the edge of a glass microscope slide. Remove the compound remaining in the eroded hole with a suitable instrument as completely as possible and weigh on an analytical balance. Determine the density of the plastic compound separately. Calculate the volume of the plastic compound removed from the eroded holes and record as the eroded volume.

#### A1.4 Report

A1.4.1 Report the following information:

A1.4.1.1 Type and designation of material tested,

---

<sup>9</sup> Johns-Manville Duxseal has been found satisfactory. Silicon RTV rubber has also been used after being allowed to set in place.

A1.4.1.2 Details of specimen fabrication, including size, thickness, cleaning procedure and solvent used, surface finishing, if any, preconditioning etc.,

A1.4.1.3 Orientation of the specimen in respect to electrodes (that is, machine direction, cross-machine direction, warp direction, fill direction, etc.),

A1.4.1.4 Contaminant composition, concentration, conductivity and temperature of liquid during conductivity measurement.

A1.4.1.5 Test voltage or voltages and the associated rate of contaminant application,

A1.4.1.6 Time of voltage application,

A1.4.1.7 Maximum depth of erosion,

A1.4.1.8 Eroded volume,

A1.4.1.9 Nature and qualitative amount of debris in the eroded area before removal, and

A1.4.1.10 Rate of contaminant application not only at the beginning but also at the end of the test.

## A2. DETAILS OF CONTAMINANT SOURCE AND ITS CALIBRATION

### A2.1 Outline

A2.1.1 This method of test requires a source of liquid contaminant supplied very slowly at a constant rate which can be varied. An automatic pipet can be pneumatically actuated at an automatic, preset rate (that is, 1, 2, 4, 6, etc., times per minute). Alternatively, peristaltic pumps have been successfully used.<sup>10</sup>

### A2.2 Components

A2.2.1 *Automatic Pipet*, 1-mL total capacity,<sup>11</sup>

A2.2.2 *Contaminant Feed Hose*, approximately 0.150 in. (3.75-mm) in inside diameter.

A2.2.3 *Actuating Air Cylinder*—The air cylinder must have a stroke sufficient to operate the automatic pipet with a locking collar that can control the length of the stroke and consequently the amount of contaminant delivered per stroke. It is possible that an electric solenoid can be substituted for the air cylinder.

A2.2.4 *Timed Contactor for Operating Air Cylinder*—A simple, suitable mechanism utilizes removable rods mounted at intervals around the radius of a small wheel driven by a shaded pole motor at 1 rpm. The rods actuate a small switch. The number of air cylinder operations per minute is controlled by the number of rods used. See Fig. 1.

A2.2.5 *Ballast Vitreous Ceramic Resistors*, 50, 10, and 1000Ω .

A2.2.6 *Filter paper*, acid washed, low ash, fine texture.

---

<sup>10</sup> The Watson-Marlow Micrometering Pump or the Dial-A-Pump Pump, or their equivalent, have been found satisfactory for this method.

<sup>11</sup> The Veripet-Manostat Corp., silicone-rubber O-ring, 0.0935 in. (2.4 mm) in inside diameter and 0.141 in. (3.6 mm) in outside diameter, is recommended as a plunger seal. Aupette-Clay-Adams, Inc. silicone lubricant is recommended for the glass plunger. An O-ring is required for the metal plunger of Fig. 7.

A2.2.7 *Automatic Double Valve*,<sup>12</sup> attached to pipet. The variation in contaminant-flow rate is greatly reduced by cutting down a standard automatic-valve spring so that the modified length is  $\frac{5}{32}$  in. (4.0 mm). The cut end of the spring must be formed in a similar manner to the original and so that it will not hang up on the screw threads. This new spring is only necessary for the inlet valve to assist its closing. The outlet valve spring remains in place and unchanged.

A2.2.8 *Cannula* (syringe needle with rounded tip), 22-gage (0.71-mm) attached to a double valve discharge.

A2.2.9 *Contaminant Delivery Hose*, from the cannula, approximately 0.022 in. (0.56 mm) in inside diameter (for use with the 22-gage [0.71-mm] cannula tip).

### A2.3 Mechanical Details—Solenoid-Valve Air System

A2.3.1 The assembled display of one test station is shown in Fig. 6. A possible schematic of the complete test facility is shown in Fig. 1.

A2.3.2 Except for air or contaminant leaks caused by gross defects (A2.6.3), all tendencies for syringe air leaks are eliminated by mounting the air piston-glass syringe assembly shown in Fig. 3 so that the syringe points upwards at about 20° from the vertical. Any minute air bubble which might leak into the syringe would therefore immediately be pumped out with the next stroke, so that no accumulation of the air bubbles (which will eventually arrest the pumping of the contaminant) can occur. In all cases, the bottom of the contaminant beaker must be slightly higher than any other part of the contaminant delivery system so that a positive hydrostatic head for detecting faulty syringe valves can be maintained (see A2.6.4).

---

<sup>12</sup> Becton Dickinson valve, N3094 (470V), or its equivalent, has been found satisfactory for this method.

## A2.4 Method of Operation (Refer to Fig. 7)

A2.4.1 The permissible forward stroke of the syringe piston is limited by the striking of the nylon guide bushing (Part C of Fig. 7) against the nylon syringe retainer washer (Part D of Fig. 7). This stop position for the forward stroke cannot be varied.

A2.4.2 The permissible return stroke length  $G-G$  of the syringe piston is governed by the striking of the metal tubing (Part B of Fig. 7) against the machined face (Part A) of the air cylinder adjustable bushing. Small changes  $F-F$  to add or subtract from the over-all travel  $G-G$  of the syringe piston can be obtained by loosening the knurled lock ring of the air cylinder, and screwing the air cylinder bushing (Part A) in or out. Retighten the knurled lock ring after adjustment of the air cylinder bushing.

## A2.5 Calibration Method

A2.5.1 The recommended contaminant feed rate of Table 1 can be obtained by changing the position of the air cylinder adjustable bushing as described in A2.4.1. The contaminant feed rate must be checked before and after each test, and recalibrated, if necessary, immediately before resuming or starting a new test.

A2.5.2 The contaminant feed rate of Table 1 is in multiples of 0.075 mL/min. Experience has shown that the easiest way to obtain any of these feed rates is to calibrate the system so that 0.075 mL of contaminant is ejected per stroke (that is, between 13 and 14 strokes to fill a 1-mL volumetric calibration vial); and the ejection rate per minute controlled by as many micro-switch actuating pins as necessary inserted in the cam of the 1 rpm motor of Fig. 1 in order to actuate the air solenoid valve.

## A2.6 Maintenance and Diagnosis

A2.6.1 Most changes in calibrated contaminant feed rate can be traced to either leakage past the syringe piston O-ring or to faulty pipet valves.

A2.6.2 Prolonged O-ring life of the syringe piston can be obtained by injecting, with a hypodermic syringe, a bit of distilled water as lubricant behind the O-ring past the return spring of the automatic pipet. This should be done before start-up in order to avoid rubbing the O-ring across the dried bore of the syringe.

A2.6.3 The air or contaminant leaks past the syringe piston are most often a result of one or more of the following reasons:

A2.6.3.1 *Damaged O-Ring*— Replace the O-ring. Spare O-rings should be kept in stock.

A2.6.3.2 *Improper fit of the piston within the syringe*—The glass syringe inside diameter tolerance (no two have the same inside diameter) is greater than the machining tolerance of the piston. Spare syringes should be purchased and the pistons selectively fitted to specific syringes.

A2.6.3.3 Be sure that the contaminant feed hose (between the contaminant beaker and the air syringe valve) is of adequate bore, since any restriction here would tend to cause air leak past the syringe piston O-ring during the suction stroke of the syringe piston.

A2.6.4 The bottom of the contaminant beaker should be slightly higher than the uppermost part of the glass syringe or small diameter contaminant delivery hose (see Fig. 6) in order to maintain a slight differential hydrostatic head. By leaving the contaminant delivery hose disconnected from the test specimen and with the 1-rpm motor turned off, any faulty syringe valve can be detected by the contaminant droplet which accumulates and drops off the tip of the contaminant delivery hose in a few minutes. Spare valves, spring, and valve gaskets should be stocked.

*ASTM International takes no position respecting the validity of any patent rights asserted in connection with any item mentioned in this standard. Users of this standard are expressly advised that determination of the validity of any such patent rights, and the risk of infringement of such rights, are entirely their own responsibility.*

*This standard is subject to revision at any time by the responsible technical committee and must be reviewed every five years and if not revised, either reapproved or withdrawn. Your comments are invited either for revision of this standard or for additional standards and should be addressed to ASTM International Headquarters. Your comments will receive careful consideration at a meeting of the responsible technical committee, which you may attend. If you feel that your comments have not received a fair hearing you should make your views known to the ASTM Committee on Standards, at the address shown below.*

*This standard is copyrighted by ASTM International, 100 Barr Harbor Drive, PO Box C700, West Conshohocken, PA 19428-2959, United States. Individual reprints (single or multiple copies) of this standard may be obtained by contacting ASTM at the above address or at 610-832-9585 (phone), 610-832-9555 (fax), or service@astm.org (e-mail); or through the ASTM website (www.astm.org).*