



Standard Test Methods for Complex Permittivity (Dielectric Constant) of Solid Electrical Insulating Materials at Microwave Frequencies and Temperatures to 1650°C¹

This standard is issued under the fixed designation D 2520; the number immediately following the designation indicates the year of original adoption or, in the case of revision, the year of last revision. A number in parentheses indicates the year of last reapproval. A superscript epsilon (ε) indicates an editorial change since the last revision or reapproval.

This standard has been approved for use by agencies of the Department of Defense.

1. Scope

1.1 These test methods cover the determination of relative (Note 1) complex permittivity (dielectric constant and dissipation factor) of nonmagnetic solid dielectric materials.

NOTE 1—The word “relative” is often omitted.

1.1.1 *Test Method A* is for specimens precisely formed to the inside dimension of a waveguide.

1.1.2 *Test Method B* is for specimens of specified geometry that occupy a very small portion of the space inside a resonant cavity.

1.1.3 *Test Method C* uses a resonant cavity with fewer restrictions on specimen size, geometry, and placement than Test Methods A and B.

1.2 Although these methods are used over the microwave frequency spectrum from around 0.5 to 50.0 GHz, each octave increase usually requires a different generator and a smaller test waveguide or resonant cavity.

1.3 Tests at elevated temperatures are made using special high-temperature waveguide and resonant cavities.

1.4 *This standard does not purport to address all of the safety concerns, if any, associated with its use. It is the responsibility of the user of this standard to establish appropriate safety and health practices and determine the applicability of regulatory limitations prior to use.*

2. Referenced Documents

2.1 ASTM Standards:

D 150 Test Methods for AC Loss Characteristics and Permittivity (Dielectric Constant) of Solid Electrical Insulating Materials²

D 618 Practice for Conditioning Plastics and Electrical Insulating Materials for Testing²

D 1711 Terminology Relating to Electrical Insulation²

F 131 Test Method for Complex Dielectric Constant of

Nonmetallic Magnetic Materials at Microwave Frequencies³

3. Terminology

3.1 Definitions:

3.1.1 *neper, n*—a division of the logarithmic scale wherein the number of nepers is equal to the natural logarithm of the scalar ratio of either two voltages or two currents.

NOTE 2—The neper is a dimensionless unit. 1 neper equals 0.8686 bel. With I_x and I_y denoting the scalar values of two currents and n being the number of nepers denoted by their scalar ratio, then:

$$n = \ln_e(I_x/I_y)$$

where:

\ln_e = logarithm to base e.

3.1.2 For other definitions used in these test methods, refer to Terminology D 1711.

4. Significance and Use

4.1 Design calculations for such components as transmission lines, antennas, radomes, resonators, phase shifters, etc., require knowledge of values of complex permittivity at operating frequencies. The related microwave measurements substitute distributed field techniques for low-frequency lumped-circuit impedance techniques.

4.2 Further information on the significance of permittivity may be found in Test Methods D 150.

4.3 These test methods are useful for specification acceptance, service evaluation, manufacturing control, and research and development of ceramics, glasses, and organic dielectric materials.

TEST METHOD A—SHORTED TRANSMISSION LINE METHOD

5. Scope

5.1 This test method covers the determination of microwave dielectric properties of nonmagnetic isotropic solid dielectric materials in a shorted transmission line method. This test

¹ These test methods are under the jurisdiction of ASTM Committee D-9 on Electrical and Electronic Insulating Materials and are the direct responsibility of Subcommittee D09.12 on Electrical Tests.

Current edition approved July 15, 1995. Published March 1996. Originally published as D 2520 – 66 T. Last previous edition D 2520 – 86 (1990) ^{ε1}.

² *Annual Book of ASTM Standards*, Vol 10.01.

³ *Annual Book of ASTM Standards*, Vol 03.04.

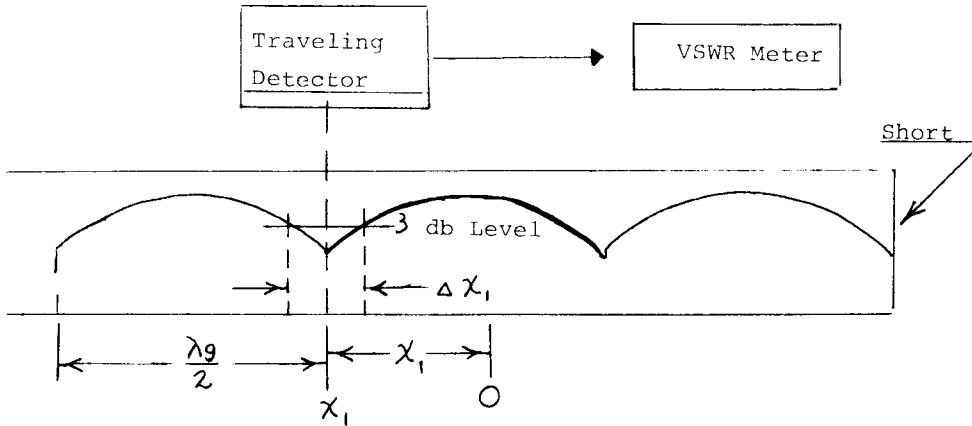

FIG. 1 Standing Wave Established Within Empty Shorted Waveguide

method is useful over a wide range of values of permittivity and loss (1).⁴ It may be used at any frequency where suitable transmission lines and measuring equipment are available. Transmission lines capable of withstanding temperatures up to 1650°C in an oxidizing atmosphere can be used to hold the specimen.

6. Summary of Test Method

6.1 In an isotropic dielectric medium, one of Maxwell's curl equations may be written

$$\text{curl } H = j\omega\kappa^*\epsilon_0 E, \quad (1)$$

assuming $\exp(j\omega t)$ time dependence,

where:

- κ^* = relative complex permittivity,
- ϵ_0 = (absolute) permittivity of free space, and
- $\omega = 2\pi f$, f being the frequency.

The notation used will be as follows:

$$\kappa^* = \kappa' - j\kappa'' = \kappa'(1 - j \tan \delta) \quad (2)$$

where:

- $\tan \delta = \kappa''/\kappa'$,
- κ' = real part, and
- κ'' = imaginary part.

The value of κ^* may be obtained from observations that evaluate the attenuation and wavelength of electromagnetic wave propagation in the medium.

6.2 The permittivity of the medium in a transmission line affects the wave propagation in that line. Thus, the dielectric properties of a specimen may be obtained by using a suitable line as a dielectric specimen holder. The electromagnetic field traveling in one direction in a uniform line varies with time, t , and with distance along the line, χ , as $\exp(j\omega t \pm \gamma\chi)$ where γ is the propagation constant. Assuming that the metal walls of the line have infinite conductivity the propagation constant γ of any uniform line in a certain mode is

$$\gamma = 2\pi(\lambda_c^{-2} - \kappa^*\lambda^{-2})^{1/2} \quad (3)$$

where:

- λ_c = cut-off wavelength for the cross section and the mode in question,
- $\lambda (= c/f)$ = wavelength of the radiation in free space, and
- κ^* = relative complex permittivity of the nonmagnetic medium.

Since κ^* is complex, γ is complex, that is,

$$\gamma = \alpha + j\beta \quad (4)$$

the field dependence on distance is therefore of the form $e^{-\alpha\chi} e^{-j\beta\chi}$. The wave attenuation is α in nepers per unit length; β is the phase constant, $\beta = 2\pi/\lambda_g$ where λ_g is the guide wavelength in the line. The method of observing α and β by impedance measurements and of representing the behavior of a line containing a dielectric by means of the formalism of transmission line impedance will be outlined briefly (1).

6.3 *Impedance Representation of the Ideal Problem*—The impedance representation of the ideal problem is illustrated by Fig. 1 for a uniform line terminated by a short. In Fig. 2 a dielectric specimen of length d_s is supposed to fill completely the cross section of the line and be in intimate contact with the flat terminating short. The impedance of a dielectric filled line terminated by a short (1), observed at a distance d_s from the short (at what is defined as the input face of the specimen) is

$$Z_{in} = (j\omega\mu_0/\gamma_2 \tanh(\gamma_2 d_s)) \quad (5)$$

where μ_0 is the permeability of free space and of the material and γ_2 is given by Eq 2, using the dimensions of the line around the specimen.

6.4 Impedance Measurement:

6.4.1 The object of the measurement is to obtain the impedance at the input face of the specimen so that the unknown γ_2 in Eq 4 may be evaluated, which in turn allows K^* to be evaluated in Eq 2. The impedance in question may be measured by a traveling probe in a slotted section of the line. As illustrated schematically in Fig. 1 and Fig. 2, the position of an electric node, that is, an interference minimum of the standing wave, is observed, and also the "width," $\Delta\chi$, of this node is observed. $\Delta\chi$ is the distance between two probe positions on either side of the node position where the power meter indicates twice the power existing at the node minimum. The voltage standing wave ratio denoted by r ($r = \text{VSWR}$) is

⁴ The boldface numbers in parentheses refer to the list of references appended to these test methods.

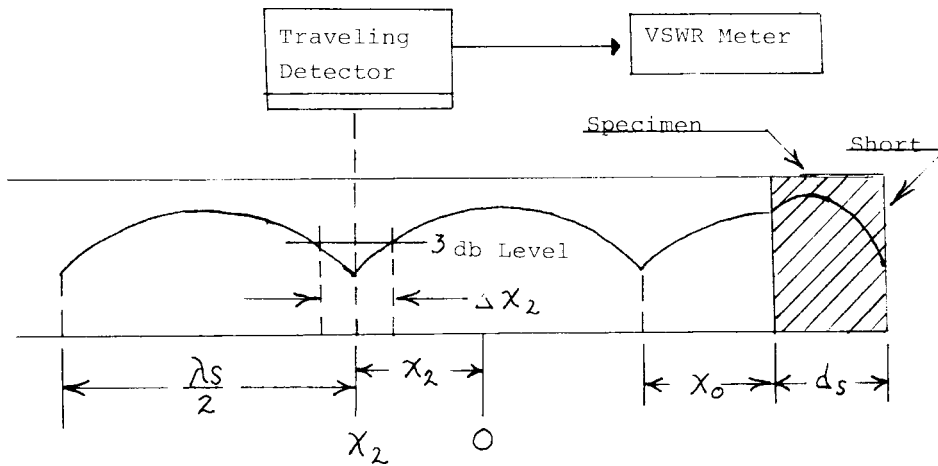

FIG. 2 Standing Wave Established Within Shorted Waveguide After Insertion of Specimen

obtained from $\Delta\chi$ by the equation (see λ_{gs} , Section 11)

$$r = \lambda / \pi \Delta\chi \quad (6)$$

NOTE 3—Refer to Appendix X2 and Appendix X3 for additional comments on errors and refinements in the method to improve accuracy. Also refer to Refs (1-4) for information on air gap corrections and use of standard materials to reduce errors and improve accuracy.

When r is small, a correction is necessary (5). The load impedance at a phase distance u away from an observed electric node having $VSWR = r$ is

$$Z_{meas} = Z_{01}(1 - jr \tan u)/(r - j \tan u) \quad (7)$$

where $Z_{01} = j\omega\mu_0/\gamma_1 = f\mu_0\lambda_g$ assuming the line is uniform and lossless.

6.4.2 It remains to determine r and u correctly, taking into account losses of the line and nonuniformity due to temperature differences, then to equate Z_{meas} and Z_{in} from Eq 6 and Eq 4, and finally to lay out a convenient calculation scheme for κ^* . The measuring procedure for obtaining r and u is discussed in Section 10.

7. Significance and Use

7.1 This test method is useful for quality control and acceptance tests of dielectric materials intended for application

at room and substantially higher temperatures. Dielectric measurement capabilities over wide ranges of temperature and over wide, continuous ranges of frequency provide significant usefulness of this method for research and development work.

8. Apparatus

8.1 See Fig. 3 for a block diagram of equipment components. Some characteristics of the component in each block are as follows:

8.1.1 *Generator*—Stable in power and frequency with low harmonic output.

8.1.2 *Square-Wave Modulator*—1.0 kHz output or frequency required for VSWR meter.

8.1.3 *Frequency Meter*—Heterodyne or cavity absorption; uncertainty 1 part in 10^4 .

8.1.4 *Isolator*—30-dB isolation, and having an output VSWR of less than 1.15.

8.1.5 *Slotted Section*—A slotted waveguide section and carriage capable of measuring gross distances to 0.025 mm (0.001 in.) and small distance to 0.0025 mm (10^{-4} in.) (for node width). A micrometer head is required; it should move parallel to the axis of the line.

8.1.6 *Probe*—Adjustable for depth. The detector must be

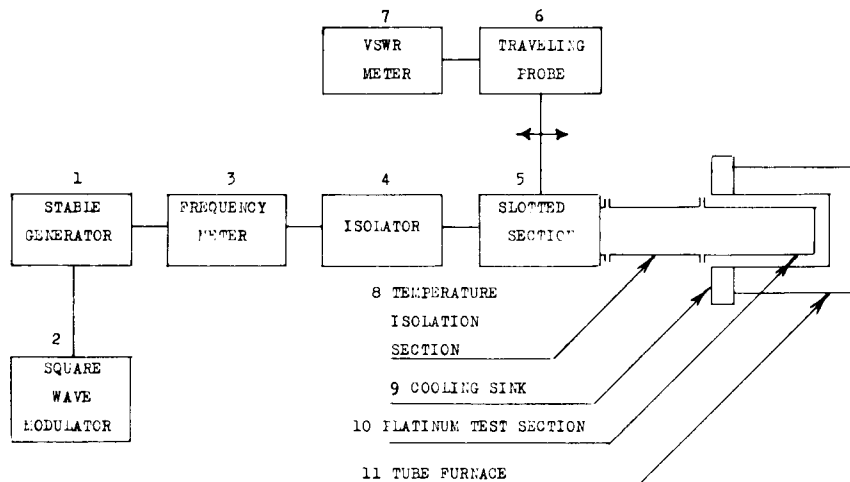

FIG. 3 Block Diagram of Apparatus Used to Perform the Measurement of Dielectric Properties by the Short Circuit Line Method

square law (6) if one uses the voltage-decibel scale of the standing wave ratio (SWR) meter. The detector must be operated in the square law region. Crystal detectors may be square law if they are not overdriven. The law of a crystal may be checked by adding a good rotating-vane microwave attenuator.

8.1.7 *VSWR Meter*—Readable in decibels.

8.1.8 *Temperature Isolation Section*— Includes a bend.

8.1.9 *Cooling Sink*—Sufficient conduction to water or air stream to maintain suitable temperature and waveguide dimensions.

8.1.10 *Waveguide Specimen Holder*—Platinum-20 % rhodium for 1650°C; platinum for temperature 1300°C; copper or silver for lower temperatures within their abilities to withstand thermal damage and corrosion. Length shall be sufficient to have a main transition region of temperature of the order of λ_g in extent and still keep sample temperature uniform to 5°C.

8.1.11 *Tube Furnace*—Platinum-wound tube furnace to accept test section, and maintain a 50-mm (2-in.) length at a constant temperature $\pm 5^\circ\text{C}$ up to 1650°C.

8.2 The so-called slope of the attenuation characteristic of the slotted line should be normal, that is, the VSWR should change by the expected amount in going from one node to another while looking into a shorted termination. Items 8.1.5, 8.1.8, and 8.1.10 shall have initial dimensions plus differential expansions at the temperature of a junction so that the change in dimensions is less than 0.25 mm (0.01 in.). The dielectric holder shall slope downward at 45 to 90° to maintain specimen against termination. Termination shall be flat to 0.010 mm (0.0004 in.) and perpendicular to axis of waveguide within $\pm 0.05^\circ$. The cross section of the holder shall meet EIA⁵ specifications; at 9 GHz this requires $\pm 0.075\text{-mm}$ (0.003-in.) tolerance on transverse dimensions.

9. Sampling

9.1 Determine the sampling by the applicable material specification.

10. Test Specimen

10.1 The transverse dimensions of the specimen shall be 0.05 ± 0.025 mm (0.002 \pm 0.001 in.) less than those of the transmission line. The front and back faces shall be parallel within 0.01 mm (0.0004 in.) and perpendicular to the axis of the transmission line within $\pm 0.05^\circ$. The corners of the specimen may be rounded slightly so the end surface seats flat against the termination with no air film between the surfaces. The length, d_s , shall be suitable for the measurement; a length of 1 mm (0.4 in.) may be used in 1 by 23-mm (0.4 by 0.9-in.) rectangular waveguide. With high loss materials the length may be limited by the electrical criterion given for $n \tan \delta$ in 12.2.2.

11. Procedure

11.1 Impedance measurements are required in the empty line (Fig. 1), and with the specimen in place (Fig. 2). The

frequency of the source and the temperature distribution of the line are to be the same for both observations. With no specimen (Fig. 1) read the position χ_1 of a voltage minimum (a node), on a scale of arbitrary origin; also measure the separation between positions either side of χ_1 where the power is +3.01 dB from the minimum. This is the width $\Delta\chi_1$ of the node. Likewise measure this analogous χ_2 and $\Delta\chi_2$ with the specimen against the termination (Fig. 2). As an additional check measurement, in one case measure the distance between two adjacent nodes. This distance is $\lambda_{gs}/2$, where λ_{gs} is the guide wavelength in the slotted section.

12. Calculation

12.1 *Measurements Transformed to Input Face of Specimen*—When measurements are made at elevated temperatures, the guide width and the guide wavelength, λ_g , vary because of the temperature gradient between the heated section and the cool (room temperature) slotted section. Fortunately the argument of the tangent in Eq 6 may be found, assuming the change in λ_g is not abrupt. The correct argument is

$$u = 2\pi[N/2 - d/\lambda_{gh} \pm (\chi_2 - \chi_1/\lambda_{gs})] \quad (8)$$

where λ_{gh} is calculated for the empty heated dielectric holder section from the dimensions duly adjusted for thermal expansion. In Eq 7 the plus sign is used if the scale for χ increases away from the short, the minus sign if the opposite. N is the smallest integer 0, 1, etc., that makes u positive. To calculate λ_{gh} use the general equation

$$\lambda_{gh}^{-2} = \lambda^{-2} - \lambda_c^{-2} \quad (9)$$

where:

$\lambda = c/f =$ free space wavelength, and

$\lambda_c =$ cutoff wavelength calculated from the dimensions.

For the TE_{10} mode rectangular guide discussed below, $\lambda_c = 2 a^*$ where a^* is the wide dimension. It remains to find the $\Delta\chi$ (width of the node) that would have been measured at the face of the specimen. The node width $\Delta\chi_1$ without the specimen is assumed to arise from the attenuation factor of the empty line, and can be treated as if it increased smoothly with distance from the short. The width contribution accumulated due to attenuation in going from the sample face to the place χ_2 where it is observed is $\Delta\chi_1(L_2 - d_s)/L_1$ where L_1 is the total length of path, $i = 1$ or 2, to the shorting termination and d_s is the length of the specimen. The node width $\Delta\chi$, transformed to the sample face is therefore obtained approximately as

$$\Delta\chi = \Delta\chi_2 - \Delta\chi_1(L^2 - d_s)/L_1 \quad (10)$$

A more exact treatment would require knowing the attenuation as a function of distance throughout. In a high temperature holder, with $L \gg d$, the approximation may be used

$$\Delta\chi = \Delta\chi_2 - \Delta\chi_1 \quad (11)$$

12.2 Equations to Be Solved:

12.2.1 Setting the impedances from Eq 4 and Eq 6 equal gives

$$\frac{\mu_0}{\gamma_2} \tanh \gamma_2 d_s = \frac{\mu_0 \lambda_{gh} (1 - jr \tan u)}{j 2\pi (r - j \tan u)} \quad (12)$$

Dividing by d_s Eq 11 is of the form $Z^{-1} \tanh Z$ equal to a known complex number, where $Z = \gamma_2 d_s$. Solutions can be

⁵ EIA Electronic Industries Association, 2001 Eye Street N.W., Washington, DC 20006.

obtained (1) and k^* calculated.

12.2.2 If $\tan \delta$ is less than 0.1 and $n \tan \delta$ is less than 0.4, where n is the number of half wave segments contained in the specimen, it is a reasonable approximation to separate real and imaginary parts in Eq 11 and obtain (7)

$$(\beta_2 d_s)^{-1} \tan \beta_2 d_s = -(\lambda_{gh}/2\pi d_s) \tan u \quad (13)$$

From Eq 2, assuming $\tan \delta$ is small,

$$\beta_2 = 2\pi(\kappa' \lambda^{-2} - \lambda_c^{-2})^{1/2} \quad (14)$$

which gives κ' after $\beta_2 d_s$ has been found in Eq 12

$$\kappa' = [(\beta_2/2\pi)^2 + \lambda_c^{-2}] \lambda^{-2} \quad (15)$$

Of course, λ_c is based on the size of the heated waveguide holder. The other part of Eq 11 gives

$$\tan \delta = \frac{\Delta \chi}{d_s} FG \quad (16)$$

where:

$$F = 1 - \kappa^2/\kappa' \lambda_c^2 \quad (17)$$

and

$$G = \frac{(1 + \tan^2 u)}{(1 + \tan^2 \beta_2 d) - \tan \beta_2 d / \beta_2 d} \quad (18)$$

The paper on separating (7) Eq 12-17 from Eq 11 may be consulted. The loss tangent in Eq 15 contains a contribution from the metal walls around the specimen; corrections are available (2, 7).

12.2.3 Finally, a correction in κ' (at least, and ideally in $\tan \delta$ also) is required due to the air gap around the specimen. Theoretical treatment (3, 8, 9) indicates that in rectangular TE_{10} guide

$$\kappa' = \kappa'_{Eq 13} \frac{b}{b_w - (b_w - b) \kappa'_{Eq 13}} \quad (19)$$

where b and b_w are the shorter cross-sectional dimensions of the specimen and guide, respectively, taking account of thermal expansion. Some experiments (10) disagree with Eq 18. The calculation scheme in Appendix X1 uses experimental corrections.

13. Report

13.1 Report the following information:

13.1.1 The unique identity of the material tested, that is, name, grade, color, manufacturer, or other pertinent data,

13.1.2 Test temperature,

13.1.3 Dimensions of specimen and waveguide holder cross section.

13.1.4 Thermal expansion coefficient of specimen and waveguide at each temperature,

13.1.5 Frequency, f ,

13.1.6 $\chi_2 - \chi_1$, and

13.1.7 Calculated value of κ' and $\tan \delta$.

14. Precision and Bias

14.1 The main sources of error in κ' are from air gaps either between the specimen and the short or in the direction of the electric field. Variations in κ' with the specimen length d_s and due to turning it over may indicate a termination air gap. The gap involved in Eq X3.20 should be carefully evaluated. A

weighted average, weighted by the sine squared across the guide, may be used. Errors in loss arise mainly from imperfection of the probe coupling and from inability to determine the losses q , $\Delta \chi_s$, and $\Delta \chi_r$. It may be helpful to verify the measurement system by measuring the loss of a standard reference material having low loss, especially when κ' is of the order of 9 to 10 (see Note 2 in 6.4.1).

TEST METHOD B—RESONANT CAVITY PERTURBATION METHOD

15. Scope

15.1 This test method covers the measurement of microwave complex permittivity of dielectric specimens in the form of rods, bars, strips, sheets, and spheres. The measurement frequency depends on the available resonant modes in a resonant cavity, which limits freedom of selection to a few values of frequency for a given cavity. Resonant cavities exhibit very high Q values (2000 to 5000 or more) and are therefore inherently sensitive for low loss measurements. The perturbation method requires that the specimen be relatively small compared to the volume of the cavity and that the specimen must be positioned symmetrically in a region of maximum electric field. Although resonant cavities are sensitive to low loss materials, the small specimen size limits the precision attainable. Nevertheless, the method has several additional advantages besides reasonably good precision:

15.1.1 Although dimensions are important and must be measured accurately, the specimen does not have to have a close tolerance fit within the specimen holder as in Test Method A.

15.1.2 The calculations for the perturbation method are relatively simple, and do not require digital computers or tables of complex functions.

15.2 The specimen shapes mentioned above have been used for ceramics and ferrites as well as homogeneous organic materials. The thin strip or sheet is adaptable to laminates.

16. Terminology

16.1 *Definitions of Terms Specific to This Standard:*

16.1.1 *electrical skin depth*—skin depth, or effective depth of field penetration, relates to high frequencies where electric currents are confined to a thin layer at the surface of conductors due to basic electromagnetic phenomena. The skin depth for copper and silver is approximately 0.002 mm at 1 GHz and decreases by a factor of 10 at 100 GHz.

16.1.2 *high Q cavity*— Q defines the bandwidth (or sharpness) of the resonance curve of field intensity plotted against frequency. Q is the reciprocal of the electrical loss with a high Q indicating low electrical losses of the cavity and dielectrics and is obtained by optimum choice of cavity dimensions, use of high conductivity metals (such as silver and copper) with highly polished surfaces (that is, surface roughness much smaller than electrical skin depth at the test frequency). High Q is enhanced by choice of large cavity volume to surface area. Surface irregularities or variations in flatness, radius of curvature or parallelism of walls, leads to spurious resonance modes which introduce electrical losses and lower the cavity Q . For rectangular cavities used in this method, the Q should be greater than 2000 and may be 5000 or more.

16.1.3 *microwave*—refers to short electromagnetic wavelengths of 30 cm or less where the corresponding frequency is 1 GHz or higher.

16.1.4 *resonant cavity*—an enclosure with conducting walls which will support electromagnetic resonance of various specific modes dependent on the cavity geometry and dimensions, and on the integral number of half waves and their directions of propagation as terminated by the cavity walls. In practice, allowance must be made for input and output coupling holes, probes, or loops. Openings or means of disassembling must be provided for introducing dielectric specimens.

17. Summary of Test Method

17.1 The introduction of a dielectric specimen into a resonant cavity lowers the resonant frequency and lowers the *Q* of the cavity. The permittivity and dissipation factor of the specimen can be calculated from measurements of resonant frequency and *Q* of the cavity with and without the specimen, and from cavity and specimen dimensions. When the specimen is small compared to wavelength, perturbation theory allows simplification of the calculations.

18. Significance and Use

18.1 This test method is useful for specification acceptance, service evaluation, manufacturing control, and research and

development of ceramics, glasses, and organic dielectric materials. It has also been widely used for magnetic ferrites as Test Method F 131.

19. Interferences

19.1 Test Method A is sensitive to magnetic permeability as well as dielectric permittivity. The test method requires that the relative complex permeability be of unit magnitude. Test Method B is insensitive to permeability since the specimen is small and is introduced in a region where the electric field is maximum and the magnetic field is zero. Although most dielectric materials have relative permeability of unity, there are materials like ferrites where both relative permittivity and permeability are greater than unity.

20. Apparatus

20.1 Fig. 4 is a sketch of a typical rectangular test cavity, which is in reality, a short section of rectangular waveguide. Metallic plates bolted or soldered to the end flanges convert the transmission line into a resonant box. An iris hole in each end plate feeds energy into and out of the cavity. The cavity electrical losses should be low, which requires the “*Q*” to be greater than 2000 (see 15.1). A clearance hole centered in opposite walls is provided so that cylindrical rod or spherical specimens can be introduced into a region of maximum electric

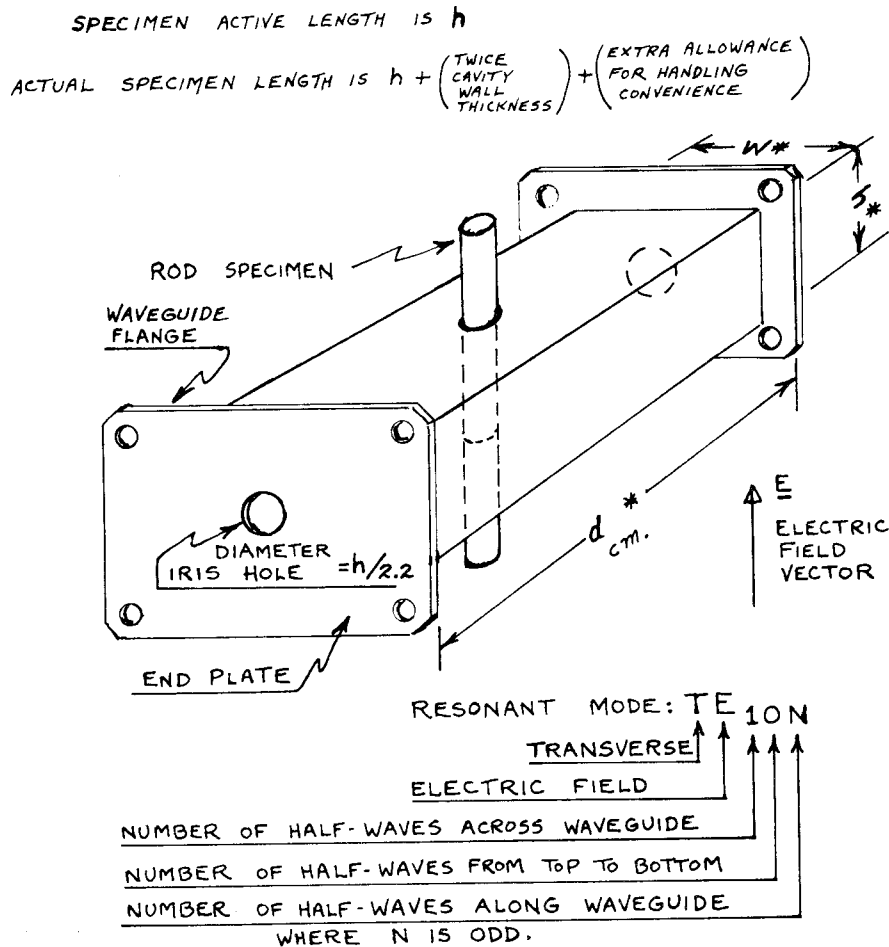

Resonant Frequency: $f_0 = 15 [(1/W)^2 + (N/d)^2]^{1/2}$ gigahertz.
 * h , w , and d are cavity inside dimensions in centimetres.

FIG. 4 Rectangular Microwave Cavity for Permittivity Measurements by the Perturbation Method

field. Strip or sheet specimens may be introduced by removing one of the end walls. A list of apparatus follows:

- 20.2 *Microwave Frequency Meter*, 6-digit precision.
- 20.3 *VSWR Meters*, or equivalent power indicators, 0.1 dB or less sensitivity.
- 20.4 *Crystal Diodes and Holders*, or bolometers.
- 20.5 *Directional Couplers*, or waveguide to coax adaptors.⁶
- 20.6 *Microwave Signal Generator*, adjustable frequency.⁶
- 20.7 *Square-Wave Modulator* (if VSWR meters used).
- 20.8 *Variable Attenuator*, precision-calibrated, 0.1 dB or less uncertainty, range 10 dB or more.⁶
- 20.9 *Variable Attenuator*.⁶
- 20.10 *Isolators*.
- 20.11 *Set Waveguide Hardware*, coaxial cables, connectors, etc.
- 20.12 Conventional VSWR meters contain high gain amplifiers tuned to 1000 Hz. This requires 1000 Hz modulation. Digital frequency meters generally do not work on square wave modulated signals. A 100-MHz digital frequency counter plus a transfer oscillator are often used by mixing a harmonic of the oscillator with the microwave signal to get a “beat frequency” null on an oscilloscope. The counter reads fundamental oscillator frequency, which when multiplied by the number of the harmonic, is equal to the microwave frequency. This method works on either modulated or unmodulated signals.

20.13 A variation of the above system uses an unmodulated signal generator connected to a digital frequency meter, followed by a crystal diode modulator or equivalent. This allows the use of sensitive VSWR meters. If modulation is omitted entirely, microwave power meters can be used, but due to lower sensitivity, a microwave amplifier may be necessary to raise the power input above noise level.

20.14 Another approach substitutes a microwave received heterodyne system instead of square wave modulation and VSWR meters. This requires an additional tuned microwave oscillator, which beats against the signal generator to produce a difference frequency of around 30 MHz, which is then amplified by a tuned I.F. amplifier and detector to get a suitable indication on a d-c milliammeter.

20.15 Fig. 5 is a block diagram of a typical microwave system for the resonant cavity perturbation method.

21. Sampling

21.1 Determine the sampling by the applicable material specification.

22. Test Specimen

22.1 *Dimensions and Tolerances:*

22.1.1 *Rod Specimens*—The diameter of rod specimens at X-band frequencies (8 to 12 GHz) should be $1.04 \pm 0.00, -0.05$ mm ($0.041 + 0.000, -0.002$ in.). The active length is the inside height of the waveguide cavity, 10.16 mm (0.4 in.). However, if the specimen is introduced through holes in the wall, the specimen length should be longer than 12.5 mm (0.5 in.) so that the ends protrude from the holes for convenience in handling. If the specimen is made 25 mm (1 in.) long,

several measurements may be made along the length to check dielectric uniformity. The 1.04-mm (0.041-in.) diameter is rather small and may be difficult to fabricate. Some laboratories have used specimen diameters as large as 2.03 mm (0.080 in.) with a resultant negative error of approximately 2 % on materials with permittivity around 8 to 10. By the use of standard specimens, it is possible to introduce corrections which will eliminate this error. Rod specimens at S-band frequencies (2.6 to 3.9 GHz) should be $3.20 + 0.00, -0.05$ mm ($0.126 + 0.000, -0.002$ in.) in diameter.

22.1.2 *Spherical Specimens*—The diameter of spherical specimens should also be small (approximately 10 % or less) compared to wavelength.

22.1.3 *Strip and Sheet Specimens*—The thickness of the strip and sheet specimens should also be small (10 % or less) compared to wavelength.

22.2 Rod specimen diameter should be measured by micrometer to within ± 0.0025 mm (0.0001 in.) at three locations along the active length and at three radial locations around the rod. These measurements are then averaged. Specimens of other shapes should also be measured at several locations to obtain an average value of critical dimensions.

22.3 Specimens should be clean and conditioned as required (see Practice D 618) since contaminants, moisture and humidity, may cause measurement errors in permittivity and dissipation factor.

23. Calibration and Standardization

23.1 Principal requirements for calibration include micrometers and calipers, precision attenuator, and frequency meter. However, for overall calibration of the method, it is desirable to obtain standard specimens of known permittivity. Such standard specimens should be periodically measured as a check on accuracy.

24. Procedure

24.1 Vary the frequency near the calculated resonant frequency of the empty cavity until resonance is indicated by a very sharp and large increase in the output power meter deflection. Introduce an attenuation for $\alpha = 3$ dB with the precision attenuator. Adjust frequency carefully until power meter indication is maximum. Note the power meter reading and measure the resonant frequency f_c . Remove the 3 dB of attenuator and adjust frequency above and below resonance to observe the two values of frequency at which the power meter repeats the value previously observed at resonance. Denote these two frequencies as f_{2c} and f_{1c} . They are the 3 dB or half power points. In very low loss measurements, it is sometimes desirable to set the attenuator points at some higher value, such as $\alpha = 10$ dB or more. Position the specimen in the cavity and repeat the above measurements of resonant frequency f_s and side frequencies f_{2s} and f_{1s} at the α dB points. Care is necessary in adjusting the frequency of the generator so as to arrive at the identical resonant mode used in the empty cavity. This is determined by always maintaining the generator frequency above the calculated $N-1$ mode of the cavity.

24.2 Record $f_c, f_{2c}, f_{1c}, f_s, f_{2s}, f_{1s}$, and α . Also record

⁶ These items cover one band of frequencies only, such as X band (8 to 11 GHz).

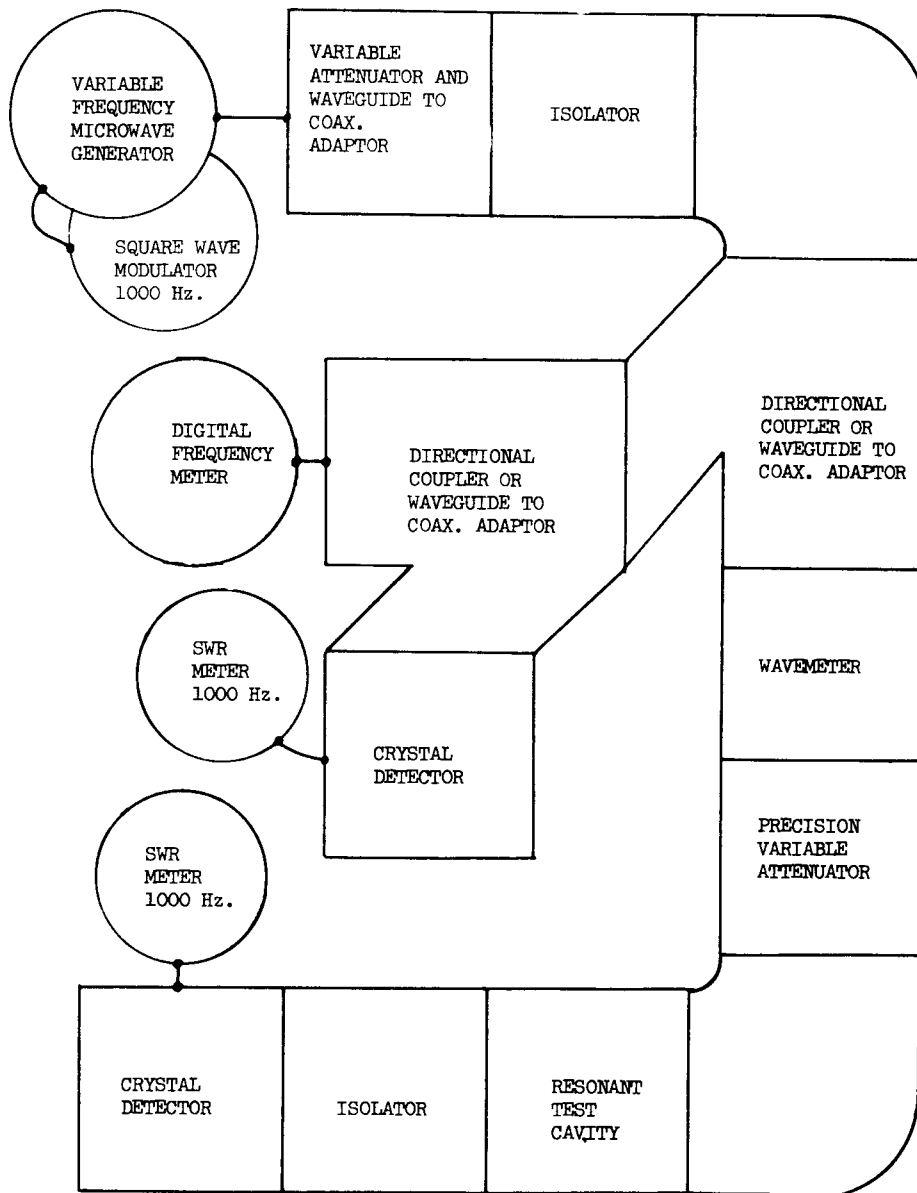

FIG. 5 Block Diagram of Typical Microwave System for Measurement of Permittivity by the Perturbation Method

specimen identity, specimen dimensions, specimen conditioning, cavity dimensions, room temperature near cavity, and relative humidity.

25. Calculation

25.1 Table 1 is a tabulation of equations for calculating relative permittivity (dielectric constant), loss index, and dissipation factor (loss tangent). These algebraic expressions were arranged in this condensed form for convenience in comparing the effect of various specimen geometries. Although Method B covers perturbation using small specimens, Table 1 also includes the expression for a specimen which completely fills the cavity, where K' is inversely proportional to frequency squared. The proportionality of the empty cavity loss to the square root of frequency is also demonstrated. The calculations for a full cavity and for small perturbation specimens are relatively simple. Calculations for large specimens, where the cavity is only partly filled, are considerably more complicated.

25.2 Table 2 is an additional tabulation of expressions required to calculate Q (quality factor) of a cavity from the frequency bandwidth of the α dB points on the resonance curve.



26. Report

- 26.1 Report the following information:
- 26.1.1 Specimen identity,
 - 26.1.2 Specimen dimensions,
 - 26.1.3 Preconditioning,
 - 26.1.4 Temperature of the specimen during the measurement,
 - 26.1.5 Relative humidity during the measurement,
 - 26.1.6 Frequency f_s of the measurement, and
 - 26.1.7 Values of K' and D .

27. Precision and Bias

27.1 *Primary and Secondary Parameters*— Permittivity

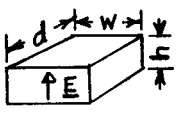
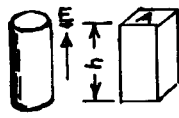
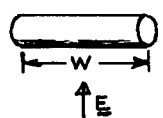
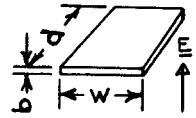
TABLE 1 Microwave Cavity Perturbation Calculations

Specimen	Volume <i>V</i>	Optimum Dimension	Relative Permittivity <i>K'</i>	Loss Index <i>K''</i>	Dissipation Factor <i>D = K''/K'</i>
FULL CAVITY^A 	<i>wdh</i>		$\left(\frac{f_c}{f_s}\right)^2$	<i>K'D</i>	$\frac{1}{Q_s} - \left(\frac{f_c}{f_s}\right)^{1/2}$
ROD, BAR^B 	$\pi r^2 h$ or <i>Ah</i>	<i>A</i> ≪ <i>wd</i>	<i>P</i>	<i>L</i>	<i>L/P</i>
ROD^B 	$\pi r^2 w$	<i>r</i> ≪ <i>h</i>	$\frac{P}{2 - P}$	$\frac{2L}{(2 - P)^2}$	$\frac{2L}{P(2 - P)}$
SHEET 	<i>wdb</i>	<i>b</i> ≪ <i>h</i>	$\frac{1}{5 - 4P}$	$\frac{4L}{(5 - 4P)^2}$	$\frac{4L}{5 - 4P}$
SPHERE 	$4\pi r^3/3$	<i>r</i> ≪ <i>w</i> <i>r</i> ≪ <i>d</i> <i>r</i> ≪ <i>h</i>	$\frac{1 + 2P}{4 - P}$	$\frac{9L}{(4 - P)^2}$	$\frac{9L}{(1 + 2P)(4 - P)}$

$$P = \frac{V_c(f_c - f_s)}{2V_s f_s} + 1$$

$$L = \frac{V_c}{4V_s} \left(\frac{1}{Q_s} - \frac{1}{Q_c} \right)$$

f_c = Resonant frequency of empty cavity

f_s = Resonant frequency with specimen

Q_c = Quality factor of empty cavity

Q_s = Quality factor with specimen

^A Perturbation method not used on full cavity; included for comparison only.

^B Specimen length shown is "active" length. Actual length longer, extends through holes in cavity walls.

TABLE 2 "Q" Measurement of Resonant Cavity

Calculation Equation

$$1/Q = (f_{2\alpha} - f_{1\alpha})/Bf_0$$

α Attenuation cavity output power level with respect to the power level at resonance due to detuning frequency (in units of decibels).

f_{2α} Frequency setting above resonant frequency which results in a decrease of *α* dB down from power level at resonance (in units of gigahertz).

f_{1α} Frequency setting below resonant frequency which results in a decrease of *α* dB down from power level at resonance (in units of gigahertz).

f₀ Resonant frequency of cavity (in units of gigahertz).

B $(10^{\alpha/10} - 1)^{1/2}$

Example: When *α* = 3 dB, *B* = 1.00

α = 10 dB, *B* = 3.00

Q_c Quality factor of empty cavity at specific resonant mode.

Q_s Quality factor of the same cavity at the same resonant mode after inserting specimen.

and dissipation factor are calculated from equations which require measurements of three primary parameters. These are: electrical frequency, cavity dimensions, and specimen dimensions. It is obvious that the precision of the calculated value depends on the measurement precision of each parameter and on the nature of the equations used for calculation. In addition to the primary parameters themselves, there are secondary

parameters which must be measured or compared in order to obtain the primary data. Cavity input and output power are important secondary parameters which enter into a consideration of overall precision.

27.1.1 *Electrical Frequency*—Digital frequency meters will measure microwave frequency with an uncertainty of only one part in ten million. The frequency error contributed by a

phase-locked frequency meter is negligible. However, if a heterodyne technique with manually adjusted transfer oscillator is used, some operator skill and judgement are required to null the oscilloscope pattern properly each time. Also, since manual nulling requires more time than an automatic phase-locked meter, frequency drift of the generator source is more critical and may cause errors. Such errors may be minimized by repetition of readings until the desired precision is demonstrated. The precision of frequency measurements is usually not limited by the precision of the frequency meter, but by precision in setting the secondary parameter: power level.

27.1.2 Power Level—Microwave power meters or VSWR meters (indicators) are required to measure cavity input and output power. The input power is maintained constant at some arbitrary level which must be high enough so that the output power is above the electrical background noise level. The output meter indicates maximum reading when the frequency is tuned to resonance. It also indicates when output power is at the desired 3 or 10-dB level down from the resonance peak value. In the case of resonance detection, the principal requirement of the meter is sensitivity of the order of 0.1 dB or better. In the case of the 3 or 10-dB power level indication, an additional requirement is precision capable of repeating a given reading within 0.1 dB or better. If power level is measured with a calibrated attenuator, there are no further requirements on the power meter. If instead, the power meter is used to indicate various power levels directly, then it must be calibrated for 0.1 dB uncertainty or less. If a crystal detector is used with a VSWR meter, the power level must fall within the square law range of the crystal.

27.1.3 Linear Measurements—Specimen dimensions and cavity inside dimensions must be measured to better precision than that required for the calculated values of permittivity and dissipation factor. If specimen diameter is measured with an uncertainty of 0.25 %, the uncertainty of specimen volume will be 0.5 %. Cavity volume remains relatively constant and needs to be measured only once.

27.1.4 Temperature—The permittivity and dissipation factor of many materials are a function of temperature. Also, electrical conductivity (and power loss) of the metallic cavity walls is a function of temperature. Therefore, temperature should be maintained constant and should be recorded as part of the test data.

27.2 Contributing Characteristics—In addition to the primary and secondary parameters, there are other important characteristics of the method and test equipment which influence precision but are more difficult to evaluate quantitatively, such as effect of cavity holes and imperfections, effect of specimen size, shape, and homogeneity.

27.2.1 Specimen Size—Perturbation theory requires that the introduction of the specimen into the cavity shall cause only a small change in the resonant frequency. This means that specimen size, or permittivity, should be small. See 22.1.

27.2.2 Iris Holes—Iris hole size should be minimum for high cavity Q and low loading effects. On the other hand, the iris hole size should be maximum to improve the signal-to-noise ratio of the output power signal. In practice, a compromise is necessary. A suitable hole size is shown on Fig. 4 (11).

27.2.3 Specimen Hole—Specimens may be introduced into cavities by provision of removable end plates. However, in the case of rod and spherical specimens, it is more convenient to introduce the specimen through holes drilled in the cavity walls. These holes, and the fringing fields at the clearance space between specimen and hole edges, introduce small errors in permittivity and loss. If clearance is held to a few thousandths of an inch, the estimated error is less than ½ % in permittivity and around 0.0002 in dissipation factor. Hole errors and corrections have been treated by Bussey and Estlin (12).

27.2.4 Specimen Homogeneity—The ideal specimen should be homogeneous and its shape uniform. For example, a rod should have no taper. In practice, a certain amount of imperfection is usually permissible. Taper and out-of-roundness of 0.005 cm (0.002 in.) is accounted for by averaging several diameter measurements. Too much irregularity will cause errors. If the specimen has directional properties due to crystal structure, fillers, or laminations, it is necessary to use a specimen with orientation of the electric field as prescribed by the application. For example, many circuit boards or striplines operate with the electric field perpendicular to the sheet. This calls for the thin strip or thin sheet measurement as shown on Table 1 where it will be noted that the electric field is also perpendicular to the plane of the sheet.

27.3 Over-all Precision—Over-all precision data are not available on all of the specimen shapes shown in Fig. 1. However, for the rod specimen, with axial field, an uncertainty of 1 to 2 % in permittivity and 5 % or 0.0002 in dissipation factor is possible.

27.4 Standard Specimens—Because of the difficulty of evaluating the combined effect of the Contributing Characteristics (27.2), it is convenient to use standard specimens fabricated from materials of known dielectric properties. Standard specimens are useful in establishing confidence in bias, precision, and for trouble-shooting and corrective action.

TEST METHOD C—RESONANT CAVITY METHOD FOR SPECIMEN OF REPRODUCIBLE GEOMETRIC SHAPE

28. Scope

28.1 This test method requires the specimen to be positioned inside a resonant cavity. However, the restrictions on small volume of specimen demanded by Test Method B are removed (13). Also, the specimen does not have to be precisely formed to the inside dimensions of a waveguide as in Test Method A. The test specimen may possess any geometric shape that can be reproduced in a material of known permittivity. It may also occupy a large proportion of the cavity volume at any location in the cavity. Symmetry of placement with respect to either microwave fields or the cavity geometry is not essential but may be preferable.

28.2 This test method covers a wide range of permittivity and dissipation factor values. This versatility is made possible because of the freedom to choose advantageous size, shape, and location of the specimen.

28.3 Because the cavity dimensions do not contribute to the calculation of results, considerable freedom is allowed on

tolerance of dimensions and geometry of the resonant cavity.

29. Terminology

29.1 *Definitions*—For definitions used in this test method refer to Section 16.

30. Summary of Test Method

30.1 The test method requires an experimental calibration for resonant cavity frequency versus permittivity of several standard specimens. These standard specimens must be identical in size and shape to the unknown piece, and their use for calibration readings requires each specimen, in turn, to occupy the exact same location in the cavity. A curve may be prepared that functionally relates the measured resonant frequency to the permittivity of each calibration specimen.

30.2 The unknown specimen is positioned at the same location that was used for the standard specimens and the cavity resonant frequency and Q are measured. The permittivity is determined through direct reference to the previously determined frequency calibration. An evaluation of $\tan \delta$ for the unknown is made through a simple calculation that includes values of measured cavity Q and the slope of the permittivity calibration curve at the resonant frequency of the unknown.

30.2.1 Cavity dimensions are not included in any calculations and, accordingly, a resonator made to precision tolerances is not required. The cavity resonant and Q properties must be stable and consistently repeatable after introduction or removal of a specimen.

31. Significance and Use

31.1 This test method is useful to suppliers or consumers in the factory or in the laboratory. It can be used for sheet material, strips, bars, rods, tubes, cubes, disks, spheres, etc., as long as standard specimens of known permittivities and of identical size and shape are available. This method can be used to check dielectric uniformity within a lot of molded parts.

31.2 The same specimen used in audio or radio frequency measurements may be measured at microwave frequencies by this method. For example, the often-used disk specimen dimensioned 50.8 by 3.18 mm (2 by $\frac{1}{8}$ in.) may be tested at microwave frequencies up to X-band values without losing continuity of use of a chosen dielectric specimen. This capability can be useful in the factory or laboratory to evaluate new materials or for research and development. The use of the same specimen for several frequencies can also save the expenses of fabricating costly specimens from glass or ceramic materials.

31.3 Dielectric isotropy of materials can be measured by selecting a specimen shape, such as a cube, which can easily be aligned with respect to the direction of the electric field.

32. Interferences

32.1 Test Method C is responsive to magnetic permeability as well as dielectric permittivity. This method requires the relative complex permeability to be $1.0 + j0.0$.

33. Apparatus

33.1 See Section 20.

34. Sampling

34.1 Determine the sampling by the applicable material specification.

35. Test Specimen

35.1 *Shape of Specimen:*

35.1.1 There are no restrictions except that specimen shapes be such as to permit the fabrication of exact replicas from standard reference materials.

35.1.2 For materials that are expected to have high losses, the specimen should be relatively small and conversely for materials with low losses.

35.2 *Dimensions and Tolerances*—Dimensional accuracy requirements depend on the shape and size of the specimen and they ultimately affect the accuracy of all measurements. These requirements apply not only to the unknown specimen but equally to the calibration pieces used for obtaining resonance data. Dimensional accuracies should conform to good machining practices. Typical tolerances for a 25.4-mm (1-in.) cube should be of the order ± 0.0075 mm (0.0003 in.) between opposite faces. For a circular rod or cylinder of nominal 25.4 mm (1-in.) diameter, the tolerance may be closer (for example, ± 0.0025 mm (0.0001 in.)).

36. Calibration

36.1 See Section 23.

37. Procedure

37.1 Provide a set of standard reference specimens of accurately known, but differing, permittivity values that replicate accurately the unknown specimen size and shape. These reference pieces should possess low-loss characteristics and cover a range of permittivity values that will bracket the anticipated range of values to be encountered by the unknown specimens. Low-loss materials with permittivity values up to 100 may be purchased from various suppliers. For some circumstances, the consumer can provide his own standards by making preliminary measurements using Test Methods A or B on dielectric materials possessing the desired range of permittivities.

37.2 Choose a location in the cavity where measurements are to be made and through the successive use of each of the calibration specimens obtain the resonant frequency of the cavity for each calibration piece of known permittivity value.

37.2.1 Materials that are expected to have high losses should be located in the cavity at regions where the electric fields are relatively weak. The converse preference pertains to materials that have low loss properties.

37.3 The functional relationship between measured resonant frequencies and permittivities of the various calibration specimens may be graphically recorded or analytically represented through a mathematical expression. The choice is optional; however, prepare either so that resonant frequencies are related accurately to the permittivity of a test specimen. A typical calibration curve for a cubic specimen is illustrated in Fig. 6. This graphical example illustrates the resonance curve that results from the variation of permittivity of a 25.4-mm (1-in.) cubic specimen located in 101.6-mm (4-in.) cubical cavity and with its sides parallel to all cavity walls. Additionally, the cube rests on the bottom cavity wall surface at a region of strongest electric fields generated by a TE_{101} mode of excitation. The abscissa of the graph is chosen for the frequency coordinate since this quantity becomes the independent variable for the

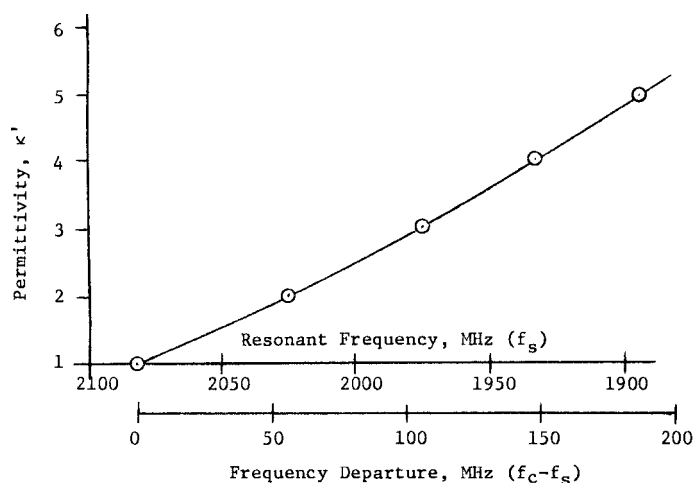

FIG. 6 Resonant Frequency for 4-in. Cubical Cavity Containing a 1-in. Cubic Specimen

evaluation of unknown specimens. Abscissa values may be plotted for either actual recorded values of resonant frequencies or for frequency departures from the empty cavity value of resonant frequency. An equivalent analytical expression representing this calibration curve may be obtained through standard curve fitting techniques using polynomial algebraic expressions, transcendental functions, etc. Typically such an expression takes the form:

$$\kappa' - 1 = AX + BX^2 + CX^3 + DX^4 \quad (20)$$

where:

$$X = \left[\left(\frac{f_c}{f_s} \right)^2 - 1 \right]$$

The coefficients *A*, *B*, *C*, *D* numerically define the functional nature of a particular specimen-cavity relationship, and

- κ' = permittivity of specimen,
- f_c = resonant frequency of empty cavity, and
- f_s = resonant frequency of cavity with a specimen.

For the calibration curve illustrated in Fig. 6, the calibration coefficients have the values:

<i>A</i> =	17.8237	<i>C</i> =	00.0000
<i>B</i> =	00.0000	<i>D</i> =	130.1460

37.4 Introduce the unknown specimen into the cavity at the exact location previously occupied by the calibration specimen. Vary the applied frequency and record $f_c, f_{1c}, f_{2c}, f_s, f_{1s},$ and f_{2s} as directed in Section 24.

38. Calculation

38.1 From the graph of permittivity versus resonant frequency (or from its equivalent mathematical equation) obtain the value of the permittivity from the observed value of f_s .

38.2 Calculate or graphically determine the value of the derivative $df_s/d\kappa'$ at that value of κ' found in 38.1. The slope may be evaluated using either resonant frequency or departure from resonant frequency as the abscissa.

38.3 Calculate $1/Q_c$ and $1/Q_s$ through standard procedures based on cavity measurements with and without the

unknown specimen. (See Method B procedure and Table 2.)

38.4 The value of the specimen loss tangent is:

$$\tan \delta = \frac{\kappa''}{\kappa'} = \frac{(-1)}{2(df_s/d\kappa')} \cdot \frac{f_s}{\kappa'} \left(\frac{1}{Q_s} - \frac{1}{Q_c} \right) \quad (21)$$

This calculated value is rendered positive through the inherent negative value of the derivative function.

39. Report

39.1 See Section 26.

40. Precision and Bias

40.1 Although precision of results attainable by this test is quite good, specific precision numbers cannot be quoted because of the arbitrary circumstances under which tests may be arranged. Precision figures may, however, be assigned a given test arrangement after the geometry of the specimen and its location in a chosen cavity is decided upon. For example, precision associated with the cubic specimen test noted under 37.3 typically yield permittivity evaluations within 0.5 % and loss tangent calculations within 4 to 5 %, or less, dependent to a large degree on the precision of measurable differences between Q_s and Q_c . Precision values of these orders of magnitude, or smaller, are typically available for all test configurations in which sufficient electric field energy is stored in the specimen. The overall cavity Q must also be sufficiently high to yield clearly defined resonances from which three decibel frequencies are measured. A specimen size and its location in a resonant cavity should be optimized to enhance measurable differences between Q_s and Q_c . In most cases, such optimization procedures are quickly performed on a trial and error basis before the required calibration replicas are made and used.

40.2 The following must be considered in order to realize maximum usefulness from this test method with particular attention to materials of high permittivity or high loss.

- 40.2.1 Practical choice of specimen shape,
- 40.2.2 Preservation of accurate, identical dimensions for all standard specimens,
- 40.2.3 Accurate assignment of permittivity values for the standard specimens,
- 40.2.4 Good resonant cavity experimental techniques pertaining particularly to:
 - 40.2.4.1 Choice of optimum location of test specimens,
 - 40.2.4.2 Identical placement of unknown and standard specimens,
 - 40.2.4.3 Consistency of closure to preserve inherent electrical properties of test cavity (dimensions and contact resistance), and
 - 40.2.5 Choice of value of α (Table 2).

41. Keywords

41.1 complex permittivity; dielectric constant; dissipation factor; microwave; permittivity; perturbation; resonant cavity; shorted transmission line

APPENDIXES

(Nonmandatory Information)

X1. SUGGESTED CALCULATION SCHEME

X1.1 Calculations are discussed in Refs (1, 4, and 7). The scheme given below may be used. In this scheme, a number in brackets will identify an item of the sequence given in Table X1.1. The input data, Items [00] to [12], are as follows:

- X1.1.1 [00] λ_{gs} as measured,
- X1.1.2 [0] T —Temperature in °C,
- X1.1.3 [1] δ_w —Coefficient of linear thermal expansion of holder,
- X1.1.4 [2] δ_s —Average coefficient of linear thermal expansion of specimen to test temperature T ,
- X1.1.5 [3] δ'_s —Total fractional expansion to T , may be used to find [2] as $\delta'_s/\Delta T$,
- X1.1.6 [4] f —Frequency,
- X1.1.7 [5] a_w —Larger width of waveguide,
- X1.1.8 [6] b_w —Smaller width of waveguide, both at room temperature (23°C),
- X1.1.9 [7] b_s —Dimension of specimen that fits b_w (Fig. X1.1),
- X1.1.10 [8] d_s —Longitudinal extent of specimen (Fig. X1.1), and
- X1.1.11 [9, 10, 11, 12]— $x_1, x_2, \Delta x_1$, and Δx_2 as measured in 11.1, see Fig. 1 and Fig. 2.

X1.2 Items [13] and [16] convert any dimension a_0, b_0 , or d_0 (at 23°C) to a^*, b^* , or d^* , its proper value at temperature T ,

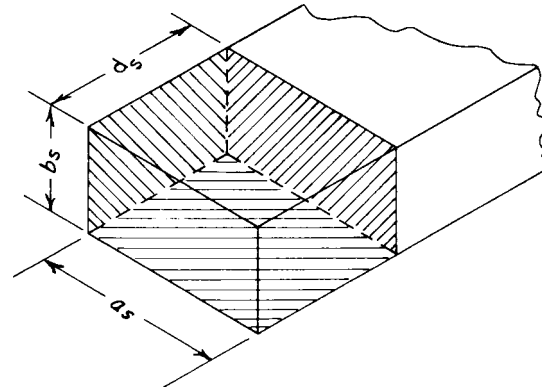

FIG. X1.1 Specimen Configuration (Shown Within Waveguide)

where $a^* = a_0(1 + \delta(t - 23))$ etc.

X1.3 All dimensions may be either in centimetres or in inches. Item [18] then requires c , the velocity of light in air, in the same units; use 2.997×10^{10} cm/s or 1.180×10^{10} in./s at sea level. Actually c is a function of the air temperature, but this is neglected.

X1.4 The N in Item [31] is chosen as discussed below Eq 8. The solution of $\tan x/x$ in Item [35] gives multiple values;

TABLE X1.1 Shorted Wave Guide Dielectric Computations
 $c = 2.997 \times 10^{10}$ cm/s or 1.180×10^{10} in./s in step [18] (see X1.3)

Quantity to Be Determined	Code Number	Coded Derivation [Operation]	Value	Quantity to Be Determined	Code Number	Coded Derivation [Operation]	Value	Quantity to Be Determined	Code Number	Coded Derivation [Operation]	Value	
λ_{gs} $T, ^\circ\text{C}$	[00]	input	$1 - P$	$\gamma\kappa'$	[21]	1 - [20]	$1 \leq \kappa_1 < 2.6$	κ_1	[42]	[41] [39]	κ_1	
	[0]	input	$\sqrt{1 - P}$		[22]	[21] ^{1/2}			[43]	[39] + [42]		
δ_w δ_s	[1]	input	$\lambda_{gh} = \lambda / \sqrt{1 - P}$	ξ	[23]	[8] ÷ [22]	$2.6 \leq \kappa_2 < 5.2$	κ_2	[44]	4.16 [28]	κ_2	
	[2]	input	d^*_s/λ_{gh}		[24]	[16] ÷ [23]			[45]	[39] + [44]		
δ'_s f a_w b_w b_s d_s x_1 x_2 Δx_1 Δx_2 a^*_w b^*_w b^*_s d^*_s $\lambda_c = 2a^*_w$ λ λ/λ_c $P = (\lambda/\lambda_c)^2$	[3]	input	$2\pi d^*_s/\lambda_{gh}$	κ_3	[25]	2π[24]	$\kappa_3 \geq 5.2$	κ_3	[46]	[39] + [41]	κ_3	
	[4]	input	$\lambda_{gh}/2\pi d^*_s$		[26]	[25] ⁻¹			[47]	[12] - [11]		
	[5]	input	b^*_s/b^*_w		[27]	[15] ÷ [14]			[48]	[47] ÷ [16]		
	[6]	input	$1 - b^*_s/b^*_w$		[28]	1 - [27]			[49]	[20] ÷ [43]		
	[7]	input	$x_2 - x_1$		[29]	[10] - [9]				[45]		
	[8]	input	$(x_2 - x_1)/\lambda_{gs}$		[30]	[29] ÷ [00]				[46]		
	[9]	input	$0 < [31] \leq 1/2$		[31]	$N/2 - [24] \pm [30]$			F	[50]		1 - [49]
	[10]	input	u		[32]	2π [31]				[51]		[33] ²
	[11]	input	$\tan u$		[33]	tangent look up				[52]		[35] [51]
	[12]	input	$\tan x/x$		[34]	-[33] [26]				[53]		[35] + [52]
[13]	A	x	[35]	table look up	[54]	-[34] [35]						
[14]	A	q_2	[36]	[26] [35]	[55]	[54] ²						
[15]	A	q_2^2	[37]	[36] ²	[56]	[35] [55]						
[16]	A	$q_2^2 - 1$	[38]	[37] - 1	[57]	[35] + [56]						
[17]	2 [13]	κ'	[39]	[21] [38] + 1	[58]	[57] - [54]						
[18]	c/f	$\kappa' - 1$	[40]	[39] - 1	[59]	[53] ÷ [58]						
[19]	[18] ÷ [17]	γ	[41]	[28] [40]	[60]	[50] [59]						
[20]	[19] ²				[61]	[48] [60]						

$^A a^* = a_0(1 + \delta(T - 23))$
 $^B b^* = b_0(1 + \delta(T - 23))$
 $^C d^* = d_0(1 + \delta(T - 23))$

choose the root that gives the expected value of κ' . If this is not known, an independent measurement at another frequency, or with d_s different, is required. Tables of $\tan x/x$ versus x are available (1).

X1.5 The corrections for the fit of the specimen, Items [42]

X2. SOURCES OF ERRORS

X2.1 The stability of the generator must be good enough so that the node position and width are repeatable in time. Frequency should be stable to 1 part in 10^5 . The probe depth should be adjusted for moderate insertion. Too much insertion pulls the standing wave pattern; too little aggravates the effect of variations in probe depth as the carriage moves, thus contributing to a false "slope" of the line.

X2.2 Generally, the standing wave pattern in the line moves when the specimen is put in. This may change the small losses and reflections occurring at joints and bends in the transition

to [46], use empirical results (10). To get κ' relative to vacuum multiply by 1.00061 (sea level conditions). The loss tangent calculation here is simplified (see 12.2.2 and section 12.2.4 for references on further corrections).

between the slotted section and the load. These effects are not evaluated here. Their presence may be detected by disagreement on specimens of different lengths. However, another source of error is higher mode resonances of the specimen. These resonances are affected by specimen length. To verify whether angle tolerances and the flatness of the specimen and the termination are adequate, measurements of κ' should be repeated with the specimen rotated 180° about an axis parallel to the axis of the transmission line. The two values of κ' should agree to within 0.5 %.

X3. TENTATIVE REFINEMENTS IN THE METHOD FOR INCREASED ACCURACY

X3.1 Refinements

X3.1.1 Sections 1-5, 7, 10 and 11, Refs (1 and 4), and Appendix X1 and Appendix X2 are used in their present form with no revisions. Refinements in Test Methods D 2520 have been incorporated into Sections 10 and 12 that appear in their revised form as the following part of Appendix X3.

X3.2 Test Specimen

X3.2.1 The transverse dimensions of the specimen shall leave sufficiently small air gaps so that the relative correction, $-1 + \kappa'/\kappa'$ in Eq X3.20, is less than 3 %. For alumina in rectangular guide a relative air gap less than 0.3 % is required, and in coaxial line the air gap around the center conductor should be 0.3 % or less. The front and back faces shall be parallel within 0.01 mm (0.0004 in.) and perpendicular to the axis of the transmission line within $\pm 0.05^\circ$. The corners of the specimen may be rounded slightly so the end surface seats flat against the termination with no air film between the surfaces. The length, d_s , shall be suitable for the measurement; a length of 10 mm (0.4 in.) may be used in 10 by 23 mm (0.4 by 0.9 in.) rectangular waveguide. With high-loss materials the length may be limited by the electrical criterion given for $n \tan \delta$ in 12.2.2.

X3.3 Calculation

X3.3.1 *Measurements Transformed to Input Face of Specimen*—When measurements are made at elevated temperatures, the guide width and the guide wavelength, λ_g , vary because of the temperature gradient between the heated section and the cool (room temperature) slotted section. Fortunately the argument of the tangent in Eq 6 may be found, assuming the change in λ_g is not abrupt. The correct argument is

$$u = 2\pi[N/2 - d/\lambda_{gh} \pm (x_2 - x_1)/\lambda_{gs}] \quad (X3.1)$$

where λ_{gh} is calculated for the empty heated dielectric holder section from the dimensions duly adjusted for thermal expansion. In Eq 7 (X3.1) the plus sign is used if the scale for x increases away from the short, the minus sign if the opposite. N is the smallest integer 0, 1, etc., that makes u positive. To calculate λ_{gh} use the general equation:

$$\lambda_{gh}^{-2} = \lambda^{-2} = \lambda_c^{-2} \quad (X3.2)$$

where:

$\lambda = c/f$ = free space wavelength, and

λ_c = cutoff wavelength calculated from the dimensions.

For the TE_{10} mode rectangular guide discussed below, $\lambda_c = 2 a^*$ where a^* is the wide dimension.

The node widths Δx_1 and δx_2 , 1 = empty, 2 = with sample, contain contributions from the metallic losses of the line. The empty width Δx_1 is investigated by measuring the width at two or more successive nodes, or by means of a quarter wave deep (nearly lossless) shorted termination, and divided up into end loss and loss per half wave length distance along the line, that is,

$$\Delta x_1 = \Delta x_t + N_c \Delta x_s \quad (X3.3)$$

where:

Δx_t = width of node contributed by termination,

Δx_s = width contributed per half wavelength, $\Delta_{gs}/2$, on the line, and

N_c = number of half wavelength from the termination to the place where Δx_1 is observed, = $2(x_0 + x_1)/\lambda_{gs}$.

If Δx_s is obtained while using an assumed lossless quarter wave short as a termination, then $\Delta x_s = \Delta x_t/N_c$. Define m as the fractional number of half wavelengths from the sample face to the place where Δx_2 is measured.

$$m = 2(x_0 + x_2 - d)/\lambda_{gs} \quad (\text{X3.4})$$

The width transferred to the input face of the sample is:

$$\Delta x = \Delta x_2 + m \Delta x_5 \quad (\text{X3.5})$$

If Δx_5 varies with distance due to temperature or metallic changes then it should be treated as a variable, $\Delta x_5(x)$.

If the sample holder is a shorted section of line that is an odd number of quarter wavelengths deep, and the thickness of the sample is chosen so that the mode x_2 is at $x_1 + d$, then minimal currents cross the connector plane. In this case, based on metallic areas and no joint behind the sample, it may be assumed that

$$\Delta x_t = \Delta x_5 ab/[2(a + b)d] \quad (\text{X3.6})$$

where a and b are the transverse waveguide dimensions.

X3.3.2 Equations to Be Solved:

X3.3.2.1 The standing wave ratio r at the face of the sample is obtained from Δx using $\theta = 2\pi\Delta x/\Delta_{gs}$ (6) in the equation

$$r = (1 + 2/(1 - \cos\theta))^{1/2} \approx \lambda_{gs}/\pi\Delta x \quad (\text{X3.7})$$

The approximate form of Eq X3.7 is Eq 5, which is sufficient for low losses. With r and u known the measured impedance, Eq 6, is known and equals the impedance at the sample face, Eq 4. These are equated:

$$(\mu_0/\gamma_2) \tanh \gamma_2 d_s = [\mu_0 \lambda_{gh}(1 - jr \tan u)]/[j2\pi(r - j \tan u)] \quad (\text{X3.8})$$

Dividing by d_s Eq 11 (X3.8) is the form $Z^{-1} \tanh Z$ equal to a known complex number, where $Z = \gamma_2 d_s$. Solutions can be obtained (1) and k^* calculated.

X3.3.2.2 If $\tan \delta$ is less than 0.1 and $n \tan \delta$ is less than 0.4, where n is the number of half wave segments contained in the specimen, it is a reasonable approximation to separate real and imaginary parts in Eq 11 (X3.8) and obtain (7)

$$(\beta_2 d_s)^{-1} \tan \beta_2 d_s = -(\lambda_{gh}/2\pi d_s) \tan u \quad (\text{X3.9})$$

From Eq 2, assuming $\tan \delta$ is small,

$$\beta_2 = 2\pi(\kappa' \lambda^{-2} = \lambda_c^{-2})^{1/2} \quad (\text{X3.10})$$

which gives κ' after $\beta_2 d_s$ has been found in Eq 12

$$\kappa' = [(\beta_2/2\pi)^2 + \lambda_c^{-2}]/\lambda^{-2} \quad (\text{X3.11})$$

Of course, λ_c is based on the size of the heated wave guide holder. The other part of Eq 11 (X3.8) gives

$$\tan \delta_{\text{wall} + \text{sample}} = FG\Delta x/d_s \quad (\text{X3.12})$$

where:

$$F = 1 - \lambda^2/\kappa' \lambda_c^2 \quad (\text{X3.13})$$

and

$$G = (1 + \tan^2 u)/[(1 + \tan^2 \beta_2 d) - \tan \beta_2 d/\beta_2 d] \quad (\text{X3.14})$$

The paper on separating (7) Eq X3.9 to Eq X3.14 from Eq

X3.8 may be consulted. The loss tangent in Eq X3.12 contains a contribution from the metal walls around the specimen; corrections are available (2, 7, 8). The losses contributed by the terminating short and the walls around the sample must be subtracted from Eq X3.12. Wavenumbers are convenient in writing the remaining equations. Define

$$k = 2\pi/\lambda; k_c = 2\pi/\lambda_c; k_{gh} = 2\pi/\lambda_{gh} \quad (\text{for the empty line}). \quad (\text{X3.15})$$

The possible extra loss of the termination contract may be accounted for by a ratio of skin depth deduced from Δx_t and Δx_5 .

$$R = \delta_t/\delta_5 = \Delta x_t \lambda_{gh}(bk_c^2 + ak^2/2)/\Delta x_5 abk_{gh}^2 \quad (\text{X3.16})$$

The equivalent loss tangent of the metal around the sample region in the absence of the sample is

$$\tan \delta_{\text{wall,e}} = (\Delta x_t/d_s + 2\Delta x_5/\lambda_{gh})k_{gh}^2/k^2 \quad (\text{X3.17})$$

The change in the metallic losses in the presence of the sample is expressed by means of:

$$\frac{\tan \delta_{\text{wall,s}}}{\tan \delta_{\text{wall,e}}} = \frac{k^2 - k_c^2}{\kappa' k^2 - k_c^2} \quad (\text{X3.18})$$

$$\left(\frac{\kappa' k^2 + 2bk_c^2/a + 2Rb(\kappa' k^2 - k_c^2)/d_s}{k^2 + 2bk_c^2/a + 2Rb(k^2 - k_c^2)/d_s} \right)$$

where a and b are the wide and narrow guide dimensions respectively. Finally the loss tangent of the specimen alone is given by

$$\tan \delta = \tan \delta_{\text{wall} + \text{sample}} - \tan \delta_{\text{wall,s}} \quad (\text{X3.19})$$

using Eq X3.12 and Eq X3.18.

X3.3.2.3 Finally, a correction in κ' (at least, and ideally in $\tan \delta$ also) is required due to the air gap around the specimen. Theoretical treatment (3, 8, 9) indicates that in rectangular TE_{10} guide

$$\kappa' = \kappa'_{\text{Eq X3.11}} [b/(b_w - (b_w - b)\kappa'_{\text{Eq X3.11}})] \quad (\text{X3.20})$$

where b and b_w are the shorter cross-sectional dimensions of the specimen and guide, respectively, taking account of thermal expansion. Some experiments (10) disagree with Eq X3.16. The calculation scheme in Appendix X1 uses experimental corrections. In a coaxial line the equations through Eq X3.14 and Eq X3.17 are correct if the limit is taken as λ_c tends to infinity. Equations Eq X3.16 and Eq X3.18 are specific to the TE_{10} mode rectangular waveguide. Analogous equations are available (2, 8) for coaxial line. In coaxial line the equation similar to Eq X3.20, for very small air gaps is

$$\kappa'_{\text{corr}} = \kappa'(\kappa' - 1)(\delta a/a + \Delta b/b)/\ln(b/a) \quad (\text{X3.21})$$

where a and b are now the inner and outer radii of the conductors respectively.

REFERENCES

- (1) Westphal, W. B., Chapter II in A. R. von Hippel, *Dielectric Materials and Applications*, The M.I.T. Press, John Wiley and Sons, New York, NY, 1954; or see Roberts, S., and von Hippel, A. R., *Journal of Applied Physics*, JACHR, Vol 17, 1946, p. 610.
- (2) Westphal, W. B., Chapter II in von Hippel, A. R., *Dielectric Materials and Applications*, The M.I.T. Press, John Wiley and Sons, New York, NY, 1954, Appendix II.
- (3) Bussey, H. E., and Gray, J. E., "Measurement and Standardization of Dielectric Samples," *IRE Transactions on Instrumentation*, Vol I-11, No. 3 and 4, December 1962.
- (4) Altschuler, H., Section 9.05, in Sucher, M., and Fox, J., *Handbook of Microwave Measurements*, 3rd Ed., John Wiley & Sons, New York, NY, Vol II.
- (5) Ginzton, E. L., *Microwave Measurements*, McGraw-Hill Book Co., New York, NY, 1959, Table 5.3; or von Hippel, A. R., *Dielectric Materials and Applications*, The M.I.T. Press, John Wiley and Sons, New York, NY, 1954, Chapter II, Appendix III.
- (6) Ginzton, E. L., *Microwave Measurements*, McGraw-Hill Book Co., New York, NY, 1959, Table 5.2.
- (7) Dakin, T., and Works, C., "Microwave Dielectric Measurements," *Journal of Applied Physics*, Vol 18, 1947, p. 789.
- (8) Westphal, W. B., "Techniques of Measuring Permittivity and Permeability of Liquids and Solids ... 3 c/sec to 50 kMc/s," M.I.T. Laboratory for Insulation Research, Cambridge, MA, *Report No. 36*, July 1950, Chapter VIII-H.
- (9) Gevers, M., "Measurement of Dielectric and Magnetic Properties of Solids at Microwave Frequencies," *Proceedings*, Symposium on Precision Electrical Measurement, Paper No. 3, Her Majesty's Stationery Office, York House, Kingsway, London, England, 1955, pp. 1–16.
- (10) Bowie, D. M., and Huminik, J., Jr., OSU-WADC Radome Symposium, Columbus, OH, June 1958.
- (11) Bady, I., and Collins, T., "Dielectric Constant and Loss Tangent of Microwave Ferrites at Elevated Temperatures," *IEEE Transactions on Microwave Theory and Techniques*, Vol MTT-11, No. 4, July 1963, pp. 222–226.
- (12) Bussey, H. E., and Estlin, A. J., "Errors in Dielectric Measurements Due to a Sample Insertion Hole in a Cavity," *IRE Transactions on Microwave Theory and Techniques*, Vol MTT-8, 1960, pp. 650–653.
- (13) Rueggeberg, W., "Determination of Complex Permittivity of Arbitrarily Dimensioned Dielectric Modules at Microwave Frequencies," *IEEE Transactions on Microwave Theory and Techniques*, Vol MTT-9, No. 6, June 1971, pp 517–521.

The American Society for Testing and Materials takes no position respecting the validity of any patent rights asserted in connection with any item mentioned in this standard. Users of this standard are expressly advised that determination of the validity of any such patent rights, and the risk of infringement of such rights, are entirely their own responsibility.

This standard is subject to revision at any time by the responsible technical committee and must be reviewed every five years and if not revised, either reapproved or withdrawn. Your comments are invited either for revision of this standard or for additional standards and should be addressed to ASTM Headquarters. Your comments will receive careful consideration at a meeting of the responsible technical committee, which you may attend. If you feel that your comments have not received a fair hearing you should make your views known to the ASTM Committee on Standards, at the address shown below.

This standard is copyrighted by ASTM, 100 Barr Harbor Drive, PO Box C700, West Conshohocken, PA 19428-2959, United States. Individual reprints (single or multiple copies) of this standard may be obtained by contacting ASTM at the above address or at 610-832-9585 (phone), 610-832-9555 (fax), or service@astm.org (e-mail); or through the ASTM website (www.astm.org).