



## Standard Test Methods for Hookup Wire Insulation<sup>1</sup>

This standard is issued under the fixed designation D 3032; the number immediately following the designation indicates the year of original adoption or, in the case of revision, the year of last revision. A number in parentheses indicates the year of last reapproval. A superscript epsilon ( $\epsilon$ ) indicates an editorial change since the last revision or reapproval.

*This standard has been approved for use by agencies of the Department of Defense.*

### 1. Scope

1.1 These test methods cover procedures for testing hookup wire.

1.2 For the purposes of these test methods, hookup wire insulation includes all components of the insulation system used on single insulated conductors or an assembly of single insulated conductors such as a cable bundle and harness or flat ribbon cable. The insulating materials include not only the primary insulation over the conductor, but also insulating jackets over shielded constructions.

1.3 The test procedures and their locations are as follows:

|  | Section |
|--|---------|
| Axial Stability (Longitudinal Change) After Thermal Exposure | 21      |
| Bondability of Insulation to Potting Compounds               | 19      |
| Capacitance  | 9 to 12 |
| Cold Bend Test   | 26      |
| Concentricity  | 16      |
| Crush Resistance   | 20      |
| Dielectric Breakdown Voltage                                 | 5       |
| Dimensions   | 15      |
| Dry-Arc Tracking   | 29      |
| Dynamic Cut-Through  | 22      |
| Fluid Immersion  | 23      |
| High Temperature Shock                                       | 24      |
| Insulation-Continuity Proof Tests                            | 13      |
| Insulation Resistance  | 6       |
| Partial Discharge (Corona) Inception and Extinction Voltage  | 25      |
| Relative Thermal Life and Temperature Index                  | 14      |
| Strip Force  | 27      |
| Surface Resistance   | 7       |
| Tensile Properties   | 17      |
| Vertical Flame Test  | 18      |
| Voltage Rating of Hook-Up Wire                               | A2      |
| Voltage Withstand Test                                       | 8       |
| Wet Arc-Tracking   | 28      |

1.4 The values stated in SI are the standard. The values given in parentheses are for information only.

1.5 *This standard does not purport to address all of the safety concerns, if any, associated with its use. It is the responsibility of the user of this standard to establish appropriate safety and health practices and determine the applica-*

*bility of regulatory limitations prior to use. For specific precaution statements, see Note 10, 12.4.1.8, 18.1.3 and Note 18 and Note 20.*

### 2. Referenced Documents

#### 2.1 ASTM Standards:

- D 149 Test Method for Dielectric Breakdown Voltage and Dielectric Strength of Solid Electrical Insulating Materials at Commercial Power Frequencies<sup>2</sup>
- D 150 Test Methods for AC Loss Characteristics and Permittivity (Dielectric Constant) of Solid Electrical Insulation<sup>2</sup>
- D 257 Test Methods for DC Resistance or Conductance of Insulating Materials<sup>2</sup>
- D 374 Test Methods for Thickness of Solid Electrical Insulation<sup>2</sup>
- D 412 Test Methods for Vulcanized Rubber and Thermoplastic Rubbers and Thermoplastic Elastomers—Tension<sup>3</sup>
- D 471 Test Method for Rubber Property—Effect of Liquids<sup>3</sup>
- D 543 Practices for Evaluating the Resistance of Plastics to Chemical Reagents<sup>4</sup>
- D 618 Practice for Conditioning Plastics for Testing<sup>4</sup>
- D 638 Test Method for Tensile Properties of Plastics<sup>4</sup>
- D 1711 Terminology Relating to Electrical Insulation<sup>2</sup>
- D 1868 Test Method for Detection and Measurement of Partial Discharge (Corona) Pulses in Evaluation of Insulation Systems<sup>2</sup>
- D 2303 Test Methods for Liquid-Contaminant, Inclined-Plane Tracking and Erosion of Insulating Materials<sup>2</sup>
- D 2307 Test Method for Relative Thermal Endurance of Film-Insulated Round Magnet Wire<sup>2</sup>
- D 2436 Specification for Forced-Convection Laboratory Ovens for Electrical Insulation<sup>2</sup>
- D 2865 Practice for Calibration of Standards and Equipment for Electrical Insulating Materials Testing<sup>5</sup>
- D 3183 Practice for Rubber—Preparation of Pieces for Test

<sup>1</sup> These test methods are under the jurisdiction of ASTM Committee D-9 on Electrical and Electronic Insulating Materials and are the direct responsibility of Subcommittee D09.18 on Solid Insulations, Non-Metallic Shieldings and Coverings for Electrical and Telecommunication Wires and Cables.

Current edition approved Oct. 10, 1998. Published January 1999. Originally published as D 3032 – 72. Last previous edition D 3032 – 97.

<sup>2</sup> Annual Book of ASTM Standards, Vol 10.01.

<sup>3</sup> Annual Book of ASTM Standards, Vol 09.01.

<sup>4</sup> Annual Book of ASTM Standards, Vol 08.01.

<sup>5</sup> Annual Book of ASTM Standards, Vol 10.02.

Purposes from Products<sup>3</sup>

D 3636 Practice for Sampling and Judging Quality of Solid Electrical Insulating Materials<sup>5</sup>

D 3638 Test Method for Comparative Tracking Index of Electrical Insulating Materials<sup>5</sup>

E 29 Practice for Using Significant Digits in Test Data to Determine Conformance with Specifications<sup>6</sup>

E 104 Practice for Maintaining Constant Relative Humidity by Means of Aqueous Solutions<sup>7</sup>

E 691 Practice for Conducting an Interlaboratory Study to Determine the Precision of a Test Method<sup>6</sup>

2.2 *IEEE Standards*:<sup>8</sup>

Standard 98 Guide for the Preparation of Test Procedures for the Thermal Evaluation of Electrical Insulating Materials

Standard 101 Statistical Analysis of Thermal Life Test Data

2.3 *Federal Standard*:

Federal Specification for Tape, Gummed; Paper, Reinforced and Plain, for Sealing and Securing (PPP-T-45C)<sup>9</sup>

### 3. Terminology

3.1 *Definitions*:

3.1.1 *arc propagation*—the movement of an electric arc from its point of inception to another location.

3.1.2 *braid, n*—(1) woven, metallic wire used as a shield for insulated conductors and cables. (2) a woven fibrous protective outer covering over an insulated conductor or cable.

3.1.3 *capacitance*—see Terminology D 1711.

3.1.4 *capacitance unbalance (of a pair in a shielded cable), n*—the ratio, expressed as a percentage, of the difference in capacitance between each of two insulated conductors and the shield, to the capacitance between that conductor pair.

3.1.4.1 *Discussion*—Capacitance unbalance is also called coefficient of asymmetry or capacitance asymmetry, and is expressed in percent unbalance.

3.1.5 *concentricity, n*—the ratio, expressed in percent, of the minimum wall thickness to the maximum wall thickness.

3.1.6 *concentric-lay conductor, n*—a conductor composed of a central core surrounded by one or more layers of helically laid strands.

3.1.6.1 *Discussion*—In the most common type of concentric-lay conductor, all strands are of the same size and the central core is a single strand.

3.1.7 *dielectric breakdown voltage*—see Terminology D 1711.

3.1.8 *dissipation factor*—see Terminology D 1711.

3.1.9 *flat cable, n*—any cable with two smooth or corrugated, but essentially flat, surfaces.

3.1.10 *flat conductor, n*—a conductor with a width-to-thickness ratio arbitrarily chosen as 5 to 1 or greater.

3.1.11 *flat conductor cable, n*—a cable of flat conductors.

3.1.12 *harness, n*—one or more bundles of hookup wire tied, clamped, or otherwise fitted together for final installation; used for interconnecting electrical circuits.

3.1.13 *hookup bundle, n*—a group of insulated conductors or hookup cables grouped into an assembly prior to installation, usually with multiple breakouts.

3.1.14 *hookup cable, n*—two or more insulated conductors in a common covering, or two or more insulated conductors twisted or molded together without a common covering, or one or more insulated conductors with a conductive shield with or without an outer covering.

3.1.15 *hookup wire, n*—an insulated conductor that is used to make point-to-point connections in an electrical or electronic system.

3.1.16 *insulated conductor, n*—a conductor, covered by a layer or layers of insulating material, whose prime function is to carry electric current.

3.1.17 *insulation resistance*—see Terminology D 1711.

3.1.18 *jacket, n*—an integral covering (sometimes fabric reinforced), which is applied over the insulation, core, shield, or armor of a cable and whose prime function is to provide mechanical or environmental protection for the component(s) that it covers.

3.1.19 *primary insulation, n*—the first layer of two or more layers of insulating materials over a conductor.

3.1.19.1 *Discussion*—The prime function of primary insulation is to act as an electrical barrier.

3.1.20 *primary jacket, n*—a layer of insulating material applied over the primary insulation for the purpose of providing mechanical protection for the primary insulation.

3.1.21 *rope-lay conductor, n*—a conductor composed of a central core surrounded by one or more layers of helically laid groups of strands.

3.1.21.1 *Discussion*—This kind of conductor differs from a concentric-lay conductor in that the main wires are themselves stranded. In the most common type of rope-lay conductor, all strands are the same size and the central core is a concentric-lay conductor.

3.1.22 *round conductor flat cable, n*—a flat cable made with parallel, round conductors in the same plane.

3.1.23 *shield*—a conducting layer placed around an insulated conductor or cable to limit the penetration of electric or electromagnetic fields.

3.1.23.1 *Discussion*—A shield can be braided or served wires, foil wrap, foil-backed tape, a metallic tube or conductive polymeric compositions.

3.1.24 *solid conductor, n*—a conductor consisting of one strand.

3.1.25 *surface resistance*—see Terminology D 1711.

3.1.25.1 *Discussion*—For a fixed electrode separation, the measured surface resistance of a given hookup wire decreases as the diameter increases.

3.1.26 *temperature index, n*—a number which permits comparison of the temperature/time characteristics of an electrical insulating material, or a simple combination of materials, based on the temperature in degrees Celsius which is obtained by extrapolating the Arrhenius plot of life versus temperature to a specified time, usually 20 000 h.

<sup>6</sup> Annual Book of ASTM Standards, Vol 14.02.

<sup>7</sup> Annual Book of ASTM Standards, Vol 11.03.

<sup>8</sup> Available from the Institute of Electrical and Electronics Engineers, Inc., 345 E. 47th St., New York, NY 10017.

<sup>9</sup> Available from Standardization Documents Order Desk, Bldg. 4 Section D, 700 Robbins Ave., Philadelphia, PA 19111-5094, Attn: NPODS.

3.1.26.1 *Discussion*—For hookup wire, the symbol TI is used for temperature index and the preferred use of the TI symbol implies a time of 20 000 h obtained by analysis of aging data in which extrapolation is limited to no more than 25°C below the lowest aging temperature (See also Section 14).

3.1.27 *thermal endurance, n*—an expression for the stability of an electrical insulating material, or a simple combination of materials, when maintained at elevated temperatures for extended periods of time.

3.1.27.1 *Discussion*—The stability of hookup wire insulation is estimated from changes in the results of voltage withstand tests on hookup wire specimens that have been heat aged, cooled to room temperature, flexed over a mandrel, immersed in salt water, and subjected to a specific applied voltage.

### 3.2 *Definitions of Terms Specific to This Standard:*

3.2.1 *cold bend test*—a test in which a specimen is slowly wrapped around a mandrel of a specified diameter after conditioning at a specified low temperature to determine that the primary insulation, primary jacket, overall jacket and any other layer of the wire or cable specimen maintains sufficient flexibility to withstand such bending at that low temperature without evidence of cracking.

3.2.2 *relative thermal endurance*—the comparison of the thermal endurance (as described by their Arrhenius plots) of two or more insulated wires designed for the same specific use; this usually implies the same size of conductor, but the insulation is of the thickness required for the particular use of each insulation.

3.2.3 *strip force*—force required to remove a specified length of insulation from an insulated wire specimen as determined by a specified test procedure.

3.2.4 *voltage withstand (proof-voltage) test*—the application of a specified voltage for a specified time to a specified configuration of the insulation. Results are expressed as “pass” or “fail.”

## 4. Sampling

4.1 Refer to the material specification for sampling plan covering specific types of hookup wire insulations.

4.2 Use Practice D 3636 as a guide if the material specification does not include a sampling plan.

## 5. Dielectric Breakdown Voltage

### 5.1 *Significance and Use:*

5.1.1 A detailed statement of significance is given in Appendix X1 of Test Method D 149.

### 5.2 *Apparatus:*

5.2.1 Use the electrical apparatus described in Test Method D 149 for this test.

### 5.3 *Test Specimens:*

5.3.1 The test specimen shall consist of insulated wire 610 mm (24 in.) in length, or of the length required for the environmental exposure. Remove the insulation for a distance of 25 mm (1 in.) at each end and twist the ends together.

### 5.4 *Procedure:*

5.4.1 Immerse the test specimen to within 152 mm (6 in.) of the twisted ends in the water bath containing 5 % sodium chloride (NaCl) and 0.05 to 0.10 % wetting agent.<sup>10</sup>

5.4.2 Use the water solution as the ground electrode, and apply the voltage to the twisted end of the conductor.

5.4.3 Raise the voltage from zero at a rate of 500 V/s until the specimen fails. If a flashover between the water solution and the twisted ends of the wire occurs, discard the specimen without retesting. Select longer specimens so that the distance between the water solution and the ends of the wire is sufficient to prevent flashover.

### 5.5 *Report:*

5.5.1 Report the following information:

5.5.1.1 Description of the specimen,

5.5.1.2 Voltage at which breakdown occurred,

5.5.1.3 Description of any previous environmental exposure given to the specimen before testing, and

5.5.1.4 Conditions under which the test was run.

## 6. Insulation Resistance

### 6.1 *Significance and Use:*

6.1.1 In high impedance circuits, insulation resistance is functionally important. In some cases, changes in insulation resistance may indicate deterioration of other properties. Insulation resistance is also useful for quality control.

NOTE 1—The term “insulation resistance” is a standard term used in the hookup wire industry to designate the resistance of a specified length of insulated wire, normally expressed as ohm-1000 ft. This is not a true insulation resistance since a resistance for a known length can be calculated and, also, the tests are conducted in a manner to eliminate surface conduction. The value obtained in this type of measurement is actually a volume resistance, but will be referred to here as insulation resistance to avoid confusion in the hookup wire industry.

### 6.2 *Apparatus:*

6.2.1 *Battery Jar*, or other insulated vessel, large enough to immerse the specimen, filled with water containing 0.05 to 0.10 % wetting agent.<sup>10</sup> The water bath shall serve as one electrode.

6.2.2 Use apparatus described in Test Methods D 257 for the resistance measurement.

### 6.3 *Test Specimens:*

6.3.1 The test specimen shall consist of a 8.3-m (or 26-ft) length of the insulated wire. Remove the insulation for a distance of 25 mm (1 in.) at each end and twist the ends together.

### 6.4 *Procedure:*

6.4.1 Immerse the specimen to within 152 mm (6 in.) of the twisted ends in the water bath, which is maintained at 23 ± 5°C (73 ± 9°F). Make an initial resistance measurement between the conductor and the water bath for the purpose of detecting nontypical values. Discard any specimen with a gross defect (that is, having an insulation resistance less than 1 × 10<sup>6</sup> Ω between the conductor and the water bath) and replace it with another specimen.

<sup>10</sup> Triton X-100 manufactured by Rohm & Haas Co., Philadelphia, PA 19106, has been found satisfactory for this test method.

6.4.2 After 4 h, remeasure the resistance between the conductor and the water bath. Make the measurement at 500 ( $\pm 10\%$ ) d-c V, after an electrification time of 1 min, unless otherwise specified.

6.5 Calculation:

6.5.1 Calculate the insulation resistance as ohm-1000 ft as follows:

$$\text{Insulation resistance, } \Omega\text{-1000 ft} = (R \times L)/1000 \quad (1)$$

where:

$R$  = measured resistance,  $\Omega$ , and

$L$  = immersed length, 25 ft.

6.5.2 Calculate the insulation resistance as  $\Omega$ -1000 m as follows:

$$\text{Insulation resistance, } \Omega\text{-1000 m} = (R \times L')/1000 \quad (2)$$

where:

$L'$  = immersed length, 8 m.

NOTE 2—Do not express insulation resistance as ohm-metre since this unit describes resistivity. It must be used as ohm for some unit of length.

6.6 Report:

6.6.1 Report the following information:

6.6.1.1 Description of the specimen,

6.6.1.2 Immersed length of the specimen,

6.6.1.3 Applied voltage,

6.6.1.4 Time of electrification,

6.6.1.5 Immersion time,

6.6.1.6 Measured resistance,

6.6.1.7 The insulation resistance of the specimen calculated in  $\Omega$ -1000 ft (or in  $\Omega$ -1000 m), and

6.6.1.8 Number of specimens discarded.

7. Surface Resistance

7.1 Significance and Use:

7.1.1 At high humidities, surface conduction may be responsible for the largest part of the leakage current in service (for example, at the terminations of bundled hookup wires).

7.1.2 Additional statements on the significance of surface resistance can be found in Test Methods D 257.

7.2 Apparatus:

7.2.1 Test Chamber—A suitable test chamber can be made from a vessel fitted with a cover through which leads have been sealed. The leads can be made from polytetrafluoroethylene (PTFE)-insulated wire, sealed with paraffin wax or silicone grease as they pass through the cover. PTFE-insulated feed-through bushings can also be used in place of the wires (Fig. 1).

7.2.2 As an alternative method, a paraffin wax collar can be fitted to the top of a glass vessel and tin-coated size 1.02 mm (AWG No. 18) solid copper wires can be sealed through the paraffin wax. A glass cover can then be used to seal the top of the test chamber (Fig. 2).

7.2.3 Use the test instruments described in Test Methods D 257 for the resistance measurement.

7.2.4 The electrical resistance of the chamber, measured between the lead wires under the conditions given in 7.3 with no specimens in place, shall be greater than  $10^{12}\Omega$ .

7.3 Test Specimens:

7.3.1 Measure five specimens.

7.3.2 The specimens shall consist of 152-mm (6-in.) lengths of finished wire, cleaned in accordance with the procedure

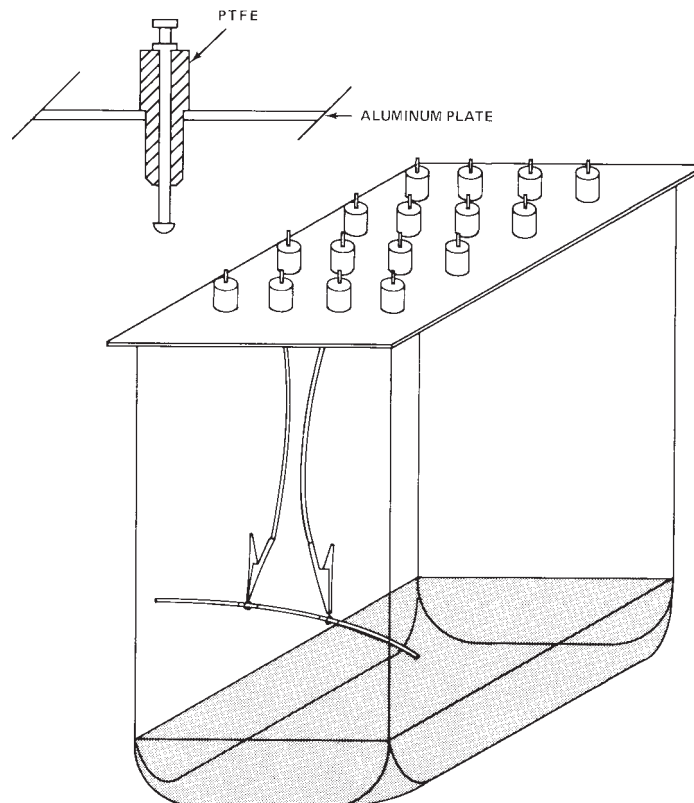

FIG. 1 Typical Surface Resistance Test Chamber Using Feed-Through Bushings

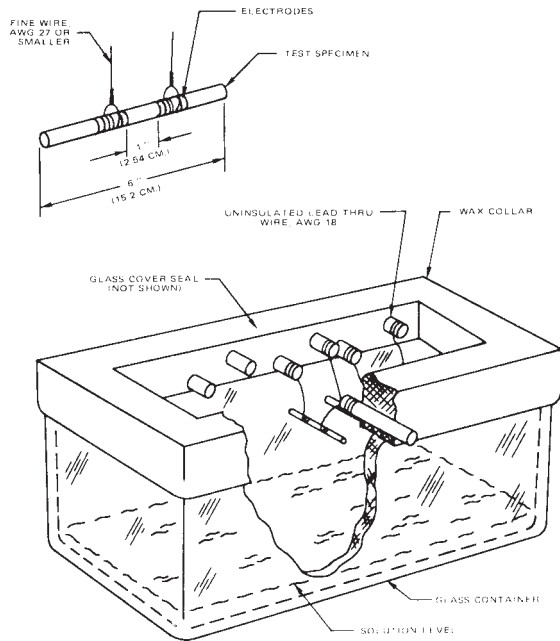

FIG. 2 Typical Surface Resistance Test Chamber Using Paraffin Wax Collar

recommended by the manufacturer. Handle the specimens subsequently with maximum care, preferably with clean lint-free gloves to avoid even the slightest contamination, including direct contact with the fingers. Provide each cleaned specimen near its center with two electrodes spaced  $25.4 \pm 0.1$  mm ( $1.0 \pm 0.005$  in.) apart between their nearest edges. Each electrode shall be approximately 13 mm ( $\frac{1}{2}$  in.) wide, and shall consist of conductive silver paint<sup>11</sup> painted around the circumference of the specimen. Make electrical connection to the dry electrodes by wrapping several turns of fine tin-coated copper wire (0.361-mm (AWG No. 27) or finer) around the electrode, leaving a free end of the fine wire of sufficient length for connecting to the electrical lead wires inside the test chamber.

7.4 Conditioning:

7.4.1 Measure the surface resistance after an exposure time of 96 h before removing the specimens from the test chamber.

7.4.2 Maintain the conditions in the test chamber within  $\pm 2^\circ\text{C}$  of a temperature selected in the range from 18 to  $27^\circ\text{C}$ , and within  $\pm 2\%$  relative humidity of a relative humidity selected in the range from 90 to 96 % relative humidity.

7.4.3 The relative humidity can be maintained over an aqueous glycerin solution described in Practice E 104.

NOTE 3—The allowable temperature variation for a given solution must be kept within the necessary range to maintain the relative humidity in the chamber to the required limits.

7.5 Procedure:

7.5.1 After the conditioning period stated in 7.3, measure the resistance between the electrodes after an electrification time of 1 min at 500 ( $\pm 10\%$ ) dc V.

NOTE 4—In some test methods the measured resistance is multiplied by the outside diameter of the insulation. The values so calculated should not

be confused with the measured values nor with the true surface resistivity of the specimen.

7.6 Report:

7.6.1 Report the following information:

- 7.6.1.1 Description of the specimen,
- 7.6.1.2 Diameter of the specimen,
- 7.6.1.3 Test conditions (temperature and relative humidity),
- 7.6.1.4 Applied voltage, and
- 7.6.1.5 Measured surface resistance.

8. Voltage Withstand Test

8.1 Significance and Use:

8.1.1 This test method is useful as a screening test for eliminating specimens unsuitable for further testing. It can also be used to determine whether exposure to environmental test conditions has reduced the breakdown strength below some prescribed level.

8.2 Apparatus:

8.2.1 Use the electrical apparatus described in Test Methods D 149 for this test.

8.2.2 Water Bath, containing 5 % sodium chloride (NaCl) and 0.5 to 0.10 % wetting agent.<sup>10</sup>

8.2.3 The sensitivity of the test equipment shall be such that a fault is indicated when one half of the specified test voltage is applied to the conductor of a length of 0.644-mm (AWG No. 22) stranded insulated wire whose other end, with the insulation cut flush with the conductor, is inserted 6.4 mm ( $\frac{1}{4}$  in.) into the test solution as far from the ground electrode as the specimen to be tested. More NaCl may be added to the solution to meet these conditions. Fault-indicating equipment is described in Test Method D 149.

8.3 Test Specimens:

8.3.1 The test specimen shall consist of insulated wire 610 mm (24 in.) in length, or of the length required for environmental exposure. Remove the insulation for a distance of 25 mm (1 in.) at each end and twist the ends together.

8.3.2 Replace any specimen having an initial gross flaw (that is, having an insulation-resistance less than  $1 \times 10^6 \Omega$  between the conductor and the solution) before exposure to environmental conditioning.

8.4 Procedure:

8.4.1 Immerse the test specimen to within 51 mm (2 in.) of the twisted ends in the water solution described in 8.2.2.

8.4.2 Measure the resistance between the conductor and the water solution at 500 ( $\pm 10\%$ ) dc V to detect gross flaws (8.3.2). Use the apparatus described in Test Methods D 257 for the resistance measurement.

NOTE 5—This screening test is performed before environmental exposure and is not repeated after the exposure.

8.4.3 After a 4-h soak, apply the voltage between the twisted ends of the conductor and the grounded water, increasing from zero to the specified value at a rate of 500 V/s. Hold the voltage on the specimen for 1 min, or for the time required in the applicable specification.

8.5 Report:

8.5.1 Report the following information:

- 8.5.1.1 Description of the specimen,
- 8.5.1.2 Electrification time and voltage,

<sup>11</sup> DuPont 4817, or equivalent, has been found satisfactory for this test method.

8.5.1.3 Description of the environmental exposure given the specimen before test,

8.5.1.4 Whether or not the specimen withstood the required voltage for the specified time,

8.5.1.5 Time for failure in case failure occurs, and

8.5.1.6 Number of specimens discarded.

## 9. Capacitance of Shielded, Single-Conductor Hookup Cable

### 9.1 Significance and Use:

9.1.1 Capacitance per unit length is useful for quality control and is sometimes required for electronic circuit design purposes.

9.1.2 Additional statements on the significance of capacitance can be found in Test Methods D 150.

### 9.2 Apparatus:

9.2.1 Use the apparatus described in Test Methods D 150 for this test method.

### 9.3 Test Specimens:

9.3.1 The specimen shall consist of a piece of shielded hookup cable approximately 3 m (10 ft) in length.

9.3.2 Remove the jacket, if any, for a distance of 25 mm (1 in.) from one end of the specimen and unbraid the shield for this distance. Remove the insulation from the conductor for a distance of 13 mm (½ in.). Twist the unbraid shield conductors together for connection to the measuring instrument and to prevent slippage of the shield on the insulation. A piece of tape over the shield can also be used to prevent slippage.

9.3.3 Terminate the opposite end of the specimen by cutting all parts of the specimen flush and perpendicular to the axis. Take care to maintain concentricity of the specimen where it is cut. Tape may be used around the shield of an unjacketed specimen to prevent slippage as long as the tape does not come in contact with the insulation or the conductor.

9.3.4 As an alternative method, both ends of the specimen can be prepared in accordance with 9.3.2. When this is done, twist the conductors from both ends of the specimen together for connection to the measuring instrument. The shields can also be twisted together.

9.3.5 Use the distance in which the shield is in contact with the insulation as the effective length of the specimen.

### 9.4 Procedure:

9.4.1 Connect the specimen to the measuring instrument and measure the capacitance. Subtract the capacitance of the terminals from the measured capacitance value (Note 6).

NOTE 6—Detailed instructions for making the measurements needed to obtain the capacitance and for making any necessary corrections due to the measuring circuit are given in the instruction books supplied with commercial equipment.

### 9.5 Report:

9.5.1 Report the following information:

9.5.1.1 Description of the specimen,

9.5.1.2 Effective length of the specimen,

9.5.1.3 Frequency at which the measurement was made,

9.5.1.4 Temperature and relative humidity at which the measurement was made,

9.5.1.5 Measured capacitance, and

9.5.1.6 Capacitance of the specimen calculated in capacitance per foot (picofarad per foot) or capacitance per metre (picofarad per metre).

## 10. Capacitance and Capacitance Unbalance of Shielded Two-Conductor Hookup Cable

### 10.1 Significance and Use:

10.1.1 Capacitance per unit length and capacitance unbalance are useful for quality control, and sometimes required for electronic circuit design purposes.

### 10.2 Apparatus:

10.2.1 Use the electrical apparatus described in Test Methods D 150 for this test method.

### 10.3 Test Specimens:

10.3.1 Prepare the specimen in accordance with 9.3, except that the insulation at one end shall be removed from both conductors for a distance of 13 mm (½ in.).

### 10.4 Procedure:

10.4.1 Designate one conductor as No. 1, the other conductor as No. 2, and the shield as No. 3.

10.4.2 The shield will be connected to one terminal of the measuring instrument for all three measurements needed to determine the capacitance of this type of specimen.

10.4.3 Measure the capacitance between conductor No. 2 at one terminal of the measuring instrument and No. 1 and No. 3 at the other terminal (Note 6). This capacitance value is  $C_a$ .

10.4.4 Measure the capacitance between conductor No. 1 at one terminal and No. 2 and No. 3 at the other terminal. This capacitance value is  $C_b$ .

10.4.5 Measure the capacitance between conductors No. 1 and No. 2 at one terminal and No. 3 at the other terminal. This value of capacitance is  $C_c$ .

10.4.6 Measure the length of lay of the twisted pair after the shield has been removed. The lay of the helically wound insulated conductors is the axial length of one turn of the helix.

### 10.5 Calculation:

10.5.1 Calculate the capacitance between the two conductors,  $C$ , as follows:

$$C = [(2(C_a + C_b) - C_c)/4] - [(C_a - C_b)^2/4 C_c] \quad (3)$$

NOTE 7—The second term of this equation is frequently neglected when the difference between  $C_a$  and  $C_b$  is small.

10.5.2 Calculate the percent capacitance unbalance as follows:

$$\text{Capacitance unbalance, \%} = [(C_a - C_b)/C] \times 100 \quad (4)$$

### 10.6 Report:

10.6.1 Report the following information:

10.6.1.1 Description of the specimen,

10.6.1.2 Effective length of the specimen,

10.6.1.3 Frequency at which the measurements were made,

10.6.1.4 Temperature and relative humidity at which the measurements were made,

10.6.1.5 Capacitance measured in 10.4.3,  $C_a$ ,

10.6.1.6 Capacitance measured in 10.4.4,  $C_b$ ,

10.6.1.7 Capacitance measured in 10.4.5,  $C_c$ ,

10.6.1.8 Capacitance calculated in 10.5.1,

10.6.1.9 Capacitance between the two conductors, picofarad per foot (capacitance per foot) or picofarad per metre (capacitance per metre).

10.6.1.10 Length of lay of the twisted pair after the shield has been removed in metres or inches, and

NOTE 8—Lay is sometimes expressed in twists per metre or twists per foot.

10.6.1.11 Capacitance unbalance calculated in 10.5.2.

**11. Capacitance of Unshielded Twisted Pair Hookup Wire**

11.1 *Significance and Use:*

11.1.1 Capacitance per unit length is useful for quality control and is sometimes required for electronic circuit design purposes.

11.2 *Apparatus:*

11.2.1 Use the electrical apparatus described in Test Methods D 150 for this test method.

11.3 *Test Specimens:*

11.3.1 The specimen shall consist of a piece of twisted pair hookup wire approximately 3 m (10 ft) in length.

11.3.2 Remove the jacket, if any, for a distance of 25 mm (1 in.), or tape the wires together 1 in. back from one end of the twisted pair. Remove 13 mm (½ in.) of the insulation from both conductors.

11.3.3 If the sample is not jacketed, tape the other end of the specimen to prevent the wires from untwisting during measurement.

11.3.4 The length that the two wires are in contact will be used as the effective specimen length (Fig. 3).

11.4 *Procedure:*

11.4.1 Suspend the uncoiled specimen at least 0.9 m (3 ft) away from possible ground planes, such as work benches, table tops, floors, etc. Any insulating material can be used to hang the specimen in the appropriate position.

11.4.2 Connect the specimen to the measuring instrument and measure the capacitance. Subtract the capacitance of the terminals from the measured capacitance value (Note 5).

11.4.3 Measure the length of lay of the twisted pair. The lay of the helically wound insulated conductor is the axial length of one turn of the helix.

NOTE 9—The capacitance of twisted pair hookup wire is dependent on the length of lay. Higher capacitance values will be obtained on specimens of the same material with shorter lengths of lay.

11.5 *Report:*

11.5.1 Report the following information:

11.5.1.1 Description of the specimen,

- 11.5.1.2 Effective length of the specimen,
- 11.5.1.3 Frequency at which the measurements were made,
- 11.5.1.4 Temperature and relative humidity at which the measurements were made,
- 11.5.1.5 Measured capacitance,
- 11.5.1.6 Capacitance of the specimen calculated, picofarads per foot (capacitance per foot) or picofarads per metre (capacitance per metre), and
- 11.5.1.7 Length of lay of the twisted pair in inches or metres (Note 9).

**12. Capacitance and Dissipation Factor of Hookup Wire Insulation by the Mercury U-Tube Method**

12.1 *Significance and Use:*

12.1.1 Capacitance per unit length and dissipation factor are useful for quality control and are sometimes required for electronic circuit design purposes. The capacitance is also needed to calculate the permittivity (dielectric constant) of an insulating material.

12.1.2 Additional statements on the significance of capacitance and dissipation factor can be found in Test Methods D 150.

12.2 *Apparatus:*

12.2.1 *Mercury U-Tube*—A suitable mercury U-tube electrode, as shown in Fig. 4.

NOTE 10—**Warning:** Mercury metal vapor poisoning has long been recognized as a hazard in industry. The maximum exposure limits are set by the American Conference of Governmental Industrial Hygienist.<sup>12</sup> The concentration of mercury vapor over spills from broken thermometers, barometers, or other instruments using mercury can easily exceed these exposure limits. Mercury, being a liquid and quite heavy, will disintegrate into small droplets and seep into cracks and crevices in the floor. The use of a commercially available emergency spill kit is recommended whenever a spill occurs. The increased area of exposure adds significantly to the mercury vapor concentration in the air. Mercury vapor concentration is easily monitored using commercially available sniffers. Spot checks should be made periodically around operations where mercury is exposed to the atmosphere. Thorough checks should be made after spills.

12.2.2 Use apparatus described in Test Methods D 150.

12.3 *Reagents:*

12.3.1 *Hydrochloric Acid (5+5).*

12.3.2 *Sodium Carbonate Solution.*

12.4 *Preparation of Apparatus:*

12.4.1 *Cleaning the U-Tube*—To assure low resistance contact between the steel U-tube and the mercury, clean the U-tube using the procedure given in 12.4.1.1-12.4.1.6, as follows:

- 12.4.1.1 Degrease the U-tube with toluene.
- 12.4.1.2 Wash with cleanser and brush.
- 12.4.1.3 Rinse with water.
- 12.4.1.4 Etch for 15 min with HCl (5+5).
- 12.4.1.5 Neutralize with Na<sub>2</sub>CO<sub>3</sub> solution.
- 12.4.1.6 Rinse with hot distilled water.
- 12.4.1.7 Fill with mercury as soon as possible after 12.3.1.6.
- 12.4.1.8 There is a health hazard present due to the toxicity of mercury vapor (see Note 10). Take suitable precautions during use. Cap the ends of the U-tube when they are not in

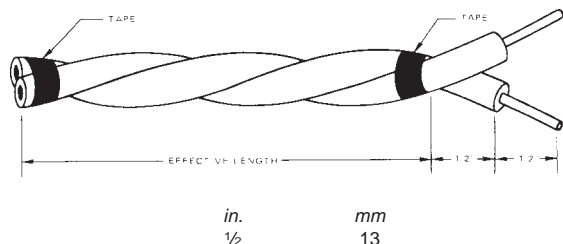
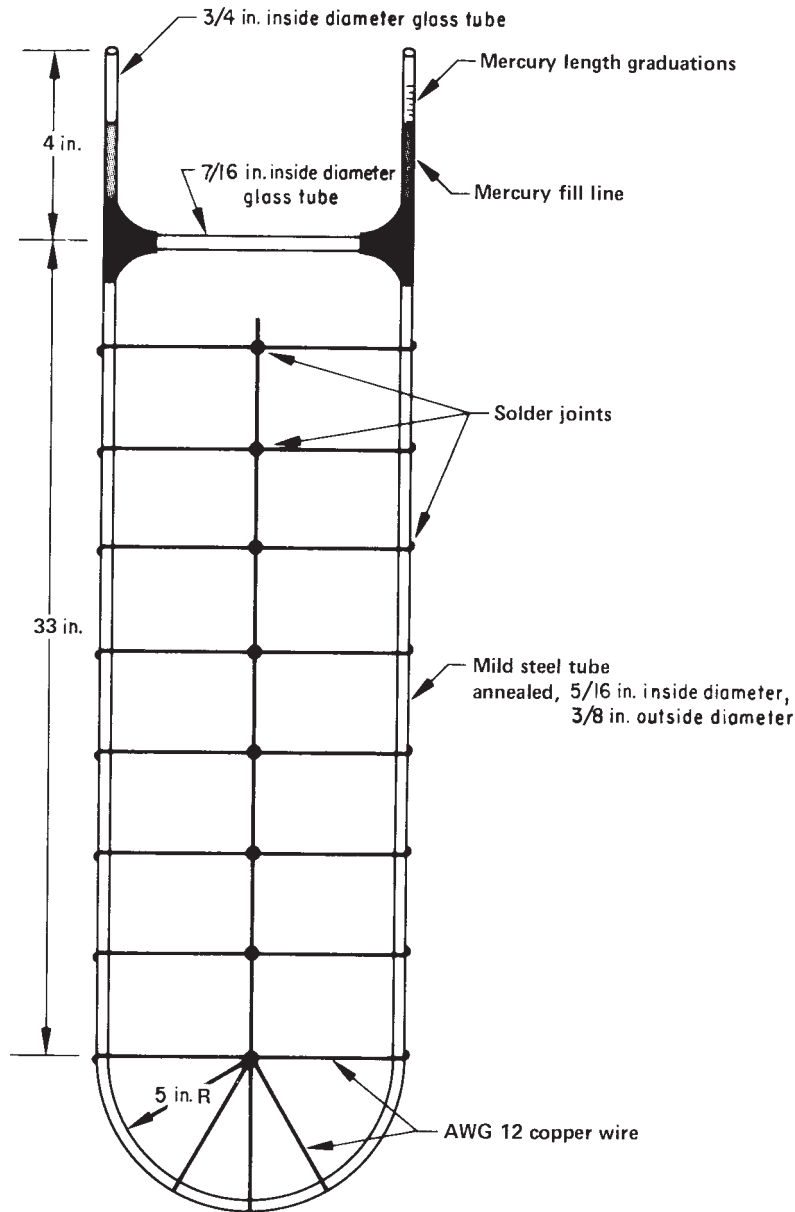

FIG. 3 Effective Specimen Length

<sup>12</sup> American Conference of Governmental Industrial Hygienists, Building D-7, 6500 Glenway Ave., Cincinnati, OH 45211.



Metric Equivalents

|     |      |      |       |       |     |     |     |
|-----|------|------|-------|-------|-----|-----|-----|
| in. | 5/16 | 3/8  | 7/16  | 3/4   | 4   | 5   | 33  |
| mm  | 7.94 | 9.53 | 11.11 | 19.05 | 102 | 127 | 838 |

FIG. 4 Mercury U-Tube Electrode System

use. Take care to remove and appropriately dispose of mercury that may adhere to the wire as it is removed from test.

12.5 Calibration of U-Tube:

12.5.1 Determine the length of the mercury in the U-tube by passing a small diameter wire or thin plastic line, that has been suitably marked off for length, through the U-tube.

12.5.2 Mark off one of the glass tubes on the top of the U-tube in 6-mm (1/4-in.) intervals from the mercury fill line so that the length of specimens of different diameters can be measured.

12.6 Test Specimens:

12.6.1 The specimen shall consist of a piece of hookup wire of sufficient length to pass through the mercury U-tube and permit joining the ends together.

12.7 Procedure:

12.7.1 Cap off one end of the specimen to prevent mercury from entering the conductor when it is inserted in the U-tube.

12.7.2 Insert the specimen in the U-tube.

NOTE 11—A thin plastic line has been found useful for pulling the specimen through the mercury U-tube. The line is reinserted as the specimen is removed.

12.7.3 Remove the insulation for a distance of 25 mm (1 in.) from each end of the specimen and twist the free ends of the conductor together.

12.7.4 Connect the measuring instrument between the twisted ends of the specimen and the copper wire frame soldered to the U-tube.

12.7.5 Measure the capacitance and dissipation factor of the specimen (see Note 5).

12.7.6 Record the effective length (the length of the specimen in contact with the mercury) of the specimen obtained from the marks on the U-tube (see section 12.4.2).

**12.8 Report:**

12.8.1 Report the following information:

12.8.1.1 Description of the specimen,

12.8.1.2 Effective length of the specimen,

12.8.1.3 Frequency at which the measurement was made,

12.8.1.4 Temperature and relative humidity at which the measurement was made,

12.8.1.5 Measured capacitance,

12.8.1.6 Capacitance of the specimen calculated in picofarad per metre or picofarad per foot,

12.8.1.7 Dissipation factor of the specimen, and

12.8.1.8 Date, laboratory, and person making the measurement.

**13. Insulation-Continuity Proof Tests**

**13.1 Scope:**

13.1.1 Insulation-continuity of hookup wire may be tested by one of the following methods:

|                 |                                   |
|-----------------|-----------------------------------|
| Method A (13.3) | Repeated-Impulse Method           |
| Method B (13.8) | 3000-Hz Sinusoidal-Voltage Method |

13.1.2 These test methods are intended to apply primarily to the final inspection of wire for the purpose of finding and eliminating defects prior to shipment or before use.

13.1.3 These test methods are also applicable to in-process testing to eliminate defects at an early stage of manufacture (that is, for wire for use in multiple-conductor cables or jacketed constructions).

**13.2 Significance and Use:**

13.2.1 In the manufacture of hookup wire, it is desirable to have long continuous lengths. Therefore, bare wire, splices, and other defects usually are not removed until the final stages of production. The insulation-continuity proof test serves as a 100 % screening test to locate and permit the removal of all such defects either as an in-process procedure or during the final spooling operation, whichever is applicable.

13.2.2 This test method may be used as a manufacturing control test and as an acceptance test immediately prior to final packaging by the producer, or as an incoming inspection by the user. In the case of its use as an acceptance test by a user, agreement should be reached between the producer and the user as to which proof test method is mutually acceptable, and that method should be specified in the applicable product or purchase specification.

13.2.3 Possible damage in handling, degradation caused by repeated testing (each voltage test may lower the ability of the wire to withstand subsequent voltage tests), and variations in test parameters all may separately or in combination produce

differences that make the comparison of results between the producer and the user difficult.

13.2.4 The insulation-continuity proof test is superior to a water-immersion test in that defects can be found and the bad sections removed during the spooling operation without damaging good insulation. Because the water bath is eliminated, the possibility of contamination of the insulated conductor is avoided.

**13.3 Apparatus,<sup>13</sup> Method A—Repeated-Impulse Method:**

13.3.1 *Electrode*—The electrode consists of a bead chain construction that will give intimate metallic contact with the wire insulation surface. The chain must be suspended in a U- or V-shaped trough having a width approximately 40 mm or 1 ½ in. greater than the diameter of the largest size of wire that is tested. The chain must have a length appreciably greater than the depth of the enclosure so that the beads will droop below the wire under test. The electrode assembly consists of an array of approximately 1.6 mm or ¼ in. diameter stainless steel bead chains suspended approximately 2.0 mm or 0.08 in. apart perpendicular to the direction of wire movement (wire line) and spaced approximately 2.5 mm or 0.10 in. apart along the wire line. The electrode length must be chosen so that at the speed being used, the wire shall be subjected to no less than 3 nor more than 100 pulses at any given point. Only one electrode will be connected to the power supply transformer. The electrode must be kept free of water and foreign matter; it must be provided with an earth grounded metal screen or equivalent guards to provide protection for the operating personnel. Broken chains must be promptly replaced as required.

13.3.2 *Power Supply*—Any impulse generator meeting the requirements of Section 13 may be used.

13.3.2.1 *Test Impulse*—The waveform of the voltage applied to the electrode head shall consist of a negative pulse, the peak magnitude of which shall be specified for the wire under test, followed by a damped oscillation. The peak impulse voltage shall be stipulated in the applicable material specification. The rise time of the negative impulse wave from zero magnitude to 90 % of the specified peak voltage shall be not more than 75 μs. The peak value of the first positive overshoot and of the subsequent damped oscillations shall be smaller than the initial negative pulse. The time during which the absolute magnitude of each voltage pulse and accompanying damped oscillation (positive and negative) remains at a value of 80 % or greater of the specified peak voltage shall be 20 to 100 μs. The pulse repetition rate shall be 200 to 250 pulses/s. Except for the final peak voltage adjustment (13.6) conformity with these impulse test parameters shall be determined with no capacitive load impressed on the electrode.

13.3.2.2 *Capacitive Tolerance*—The tolerance of the equipment to change in capacitive load shall be such that the peak output voltage shall be reduced by not more than 12 % in the event of an increase of the capacitive load, between electrode

---

<sup>13</sup> The Clinton Instrument Co. manufactures the Model TT-25 Impulse Test Calibration Set for performing the single-shot test as well as for checking compliance with the requirements for capacitance tolerance and failure sensitivity.

and ground, from an initial load of 4.9 to 9.8 pF/cm (12.5 to 25 pF/in.) of electrode length.

13.3.2.3 *Instrument Voltmeter*—A peak-reading voltmeter shall be provided, indicating continuously the potential of the electrode. The voltmeter shall have a minimum accuracy of  $\pm 3\%$  at the specified impulse potential, after calibration as specified in 13.4.

13.3.2.4 *Failure Detection Circuit*—There shall be a failure detection circuit to give a visual or audible indication, or both, of insulation failure. In addition, the electrode head may be de-energized and the drive mechanism stopped. The detection circuit shall be sufficiently sensitive to indicate a fault at 75 % of the specified test voltage when the electrode is arced to ground through a 20-k $\Omega$  resistor and shall be capable of detecting a fault that lasts for the duration of only one impulse.

13.4 *Calibration*—Calibrate the instrument voltmeter periodically (see Practice D 2865) by comparison with an external standard voltmeter having an accuracy of  $\pm 2\%$  of the reading and capable of detecting the peak potential at the electrode head, with or without auxiliary circuitry. In performing the calibration, connect the standard voltmeter to the electrode head directly or through a calibrated attenuator circuit. Adjust the impulse generator until the reading on the standard voltmeter is the specified potential, at which point the reading on the instrument voltmeter shall be observed and recorded. Repeat this calibration for each peak potential at which it is intended to operate the equipment. An alternative procedure is by means of a calibrated oscilloscope connected to the electrode through a suitable attenuator. The peak magnitude of the negative impulse can then be read directly from the waveform display. Conformance to the other waveform parameters specified in 13.3.2.1 shall be verified from the oscilloscope.

13.5 *Test Specimens*—The test specimens consist of continuous lengths of hookup wire.

13.6 *Procedure*—Thread the wire through the electrode and ground the conductor at one, or preferably both, ends. Energize the electrode to the specified peak potential and, after final adjustment of the voltage with the wire in the electrode head, pass the wire from the pay-off spool through the electrode onto the take-up spool. The speed of passage of the wire through the electrode shall be such that, after start-up, the wire is subjected to not less than 3 nor more than 100 pulses at any given point. Cut out, or mark for later removal, all sections of wire that cause the detector to trip, along with at least 50 mm (2 in.) of wire on each side of the failure. Locate the point of failure by passing the wire back through the head. If the detector does not trip again it can be assumed that the indication was false. Make every effort to test the entire length, including ends of the wire when stringing up new lengths, in accordance with this procedure. Remove all ends or other portions of the wire not so tested. When testing wire in process, or when specified in contract or order, dielectric failures, untested portions of wire, or portions that have been exposed to fewer or more than the specified number of pulses may be marked by stripping the insulation or by any other suitable method of marking as specified in the contract in lieu of being cut out of the wire.

13.7 *Report*—If required in sales to customers the producer shall certify that 100 % of wire supplied has been tested in accordance with Section 13 of these test methods.

13.8 *Apparatus, Method B 3000-Hz Sinusoidal-Voltage Method*:

13.8.1 *Electrode*—The electrode consists of a bead chain construction that will give intimate metallic contact with the wire insulation surface. The chain must be suspended in a U- or V-shaped trough having a width approximately 40 mm or 1½ in. greater than the diameter of the largest wire that is tested. The chain must have a length appreciably greater than the depth of the enclosure so that the beads will droop below the wire under test. The electrode assembly consists of an array of approximately 1.6-mm or ¼ in. diameter stainless steel bead chains suspended approximately 2.0 mm or 0.08 in. apart perpendicular to the direction of wire movement (wire line) and spaced approximately 2.5 mm or 0.10 in. apart along the wire line. The electrode length must be chosen so that at the speed being used, the wire will be subjected to no less than a total of 18 positive and negative crests of the supply voltage (the equivalent of 9 cycles) nor more than 2000 positive or negative wave crests (1000 complete cycles) at any given cross section. Only one electrode will be connected to the power supply transformer. The electrode must be kept free of water and foreign matter; it must be provided with an earth grounded metal screen or an equivalent guard to provide protection for the operating personnel. Broken chains must be promptly replaced.

13.8.2 *Power Supply*—Any 3000-Hz sinusoidal generator meeting the requirements of 13.8.2.1 through 13.8.2.5 may be used.

13.8.2.1 *Waveform*—The waveform of the voltage applied to the electrode head shall consist of a 3000  $\pm$  500-Hz sine wave, the amplitude of which shall be as specified for the wire under test and shall not change more than  $\pm 2\%$  as the line voltage varies  $\pm 15$  V from the nominal. Unless otherwise specified, the alternating voltage (root mean square) shall be the voltage called for in the applicable material specification. The ratio of the peak value to the root mean square value of the voltage shall be no less than 1.35 nor more than 1.48 under any load condition.

13.8.2.2 *Regulation*—The current which the equipment can deliver to a purely capacitive load shall be no less than 40 mA. The current that can be delivered to a purely resistive load shall be no less than 12 mA. When the load consists of a capacitance passing a current of 10 mA in parallel with a resistance passing a current of 1 mA the voltage at the test load shall not change more than 5 % between no-load and full-load conditions.

13.8.2.3 *Instrument Voltmeter*—An average indicating voltmeter capable of operating accurately at a frequency of up to 4000 Hz and calibrated to read root mean square values shall be provided. It shall continuously indicate the potential on the electrode. This a-c (root mean square) voltmeter, shall have an accuracy tolerance of not more than  $\pm 3\%$  at the specified potentials, after calibration as specified in 13.9.2 and shall be energized by a metering winding unity, coupled to the high-voltage secondary winding.

13.8.2.4 *Failure Detection Circuit*—There shall be a failure detection circuit to give a visual or audible indication, or both, of insulation failure. In addition, the electrode head may be de-energized and the drive mechanism stopped. The system shall be sufficiently sensitive so that a fault is indicated at 2 kV when the electrode is arced to the ground through a needle spark gap in series with the detection circuit for a duration of 0.001 s or less.

NOTE 12—A test set for checking sensitivity may be constructed using a turntable, with a grounded metal plate at its periphery, rotated to move the plate past a 0.13 mm (0.005 in.) phosphor bronze wire, positioned normal to the plate's surface, in 0.001 s. The wire shall be spaced 0.15 mm (0.006 in.) from the plate, and connected electrically to the output voltage of the apparatus for the duration of a single pass.

13.8.2.5 *Response After Failure Detection*— The stability and recovery of the generator and associated detection circuitry shall be such that the waveform and regulation meet the requirements for the power supply and will maintain the set test potential 40 ms after failure detection.

#### 13.9 *Calibration of Equipment:*

13.9.1 Calibrate the instrument's voltmeter periodically (see Practice D 2865) by comparison with an external electrostatic voltmeter, with or without auxiliary circuitry, having a  $\pm 1$  % full-scale accuracy. The measurements shall be made in the upper two-thirds of the standard voltmeter scale. In performing the calibration, connect the standard voltmeter to the electrode head directly. Adjust the voltage generator until the reading on the standard voltmeter is the specified potential, at which point the reading on the instrument's voltmeter shall be observed and recorded. Repeat this calibration for each potential at which the equipment is intended to operate.

13.9.2 Calibration will include a determination of the waveform with the wire to be tested in the electrode. The waveform must comply with 13.8.2.1.

#### 13.10 *Test Specimens:*

13.10.1 The test specimens will consist of continuous lengths of hookup wire.

#### 13.11 *Procedure:*

13.11.1 Thread the wire through the electrode and ground the conductor at one, or preferably, both ends. Energize the electrode to the specified potential and, after final adjustment of the voltage with the wire in the electrode head, pass the wire from the pay-off spool through the electrode onto the take-up spool at a speed not exceeding that used in 13.8.1 to determine the electrode length. Cut out, or mark for later removal, all sections of wire that cause the detector to trip, along with at least 2 in. of wire on each side of the failure. The point of failure can be located by passing the wire back through the head. If the detector does not trip again, it can be assumed that the indication was false. Every effort shall be made to test the entire length, including ends, of the wire when stringing up new lengths, in accordance with this procedure. Remove all ends or other portions of the wire not tested. For final testing of wire, or when specified in product or purchase specification, dielectric failures, untested portions of wire, or portions that have been exposed to fewer or more than the specified number of pulses may be marked by stripping the insulation or by any

other suitable method of marking as specified in the product or purchasing specification in lieu of being cut out of the length.

#### 13.12 *Report:*

13.12.1 When specified, the report shall consist of a certification that 100 % of the wire supplied has been tested in accordance with one of the methods specified in this section, at the voltage called for in the applicable product or purchasing specification. The particular method employed shall be reported.

#### 13.13 *Precision and Bias:*

13.13.1 No statement is made about either the precision or the bias of these test methods for measuring insulation-continuity since the result merely states whether there is conformance to the pass/fail criteria specified in the procedure.

## 14. **Relative Thermal Life and Temperature Index**

#### 14.1 *Scope:*

14.1.1 This test method provides a standard test and procedure for determining life versus temperature curves and temperature indices for flexible electrical insulating materials and insulating systems used as primary insulation and primary jackets on hookup wire whose conductor type is that used in practice.

#### 14.2 *Summary of Test Method:*

14.2.1 Three or four sets of specimens of a given sample of insulated wire are exposed for selected periods of time at several fixed temperatures. After each exposure period the specimen is wrapped on a mandrel to simulate a flexing stress and then immersed in a water bath where it is given a voltage withstand test. A given specimen is subjected to a continued series of exposures at its designated test temperature until failure occurs.

14.2.2 The life data at different temperatures are analyzed on the basis of the Arrhenius equation which relates exposure time to failure to the reciprocal of the absolute temperature of exposure. The method is based on the IEEE Standard No. 98. The preparation and processing of data are to be in general accordance with IEEE Standard 101.

#### 14.3 *Significance and Use:*

14.3.1 The chemical changes that degrade the physical and electrical properties of insulation on wire are accelerated when the insulated wire is exposed to elevated operating temperatures. This test method can be used to determine the relative effects of different temperatures on the life of a given insulating system or to compare different insulating systems at a given temperature. The times to failure in this test cannot be quantitatively related to the life of insulating materials in actual service, but do provide an indication of such life under the specific parameters of the test. The results of these shorter time tests at higher temperatures can be extrapolated to longer times at lower temperatures providing that the extrapolation is limited and is based on adequate data with sufficient linearity.

14.3.1.1 Embrittlement of the insulation and the loss of its electrical strength are the usual causes of failure due to thermal aging on insulated wire in practical applications; hence the failure points for these accelerated conditions are determined by standard tests of embrittlement and electrical strength.

14.3.1.2 In comparing different systems, it is important that the dimensions and constructions of each be those to be used in the intended application.

14.3.1.3 It is important to know that changing the condition of test will change the results. Decreasing the mandrel size, increasing weight during mandrel bend, bending at too high a rate, or increasing proof voltage will decrease life. Too few temperature exposure cycles will result in erroneously long life values.

14.4 Apparatus:

14.4.1 For Relative Thermal Life, a Circulating Air Oven, meeting the general requirements of Specification D 2436 and capable of operating at the required temperature.

14.4.1.1 For absolute thermal evaluation and temperature index, the oven must meet fully Specification D 2436.

14.4.1.2 The oven shall have a vertical internal dimension of at least 500 mm (20 in.).

14.4.2 Rack, for holding specimens in the oven shall be provided. A simple one can consist of 6-mm (1/4-in.) steel rods located horizontally approximately 25 mm (1 in.) below the top of the chamber. These can be mounted as a part of the chamber or as a removable rack carrying the specimens.

14.4.3 Weight with Hooks, shall be provided for holding wire specimens straight in the oven during aging. An appropriate weight size is about one-half of the mandrel test weight shown in the table in 14.4.4. It is suggested that this weight have also a hook on the bottom so that the additional weight required for the mandrel wrap can be added without removing the stabilizing weight.

14.4.4 A mandrel shall be provided, supported horizontally, and fitted at one end with a crank for mandrel test wrapping of the specimens. Support the rod at least 6 m (2 ft) above a horizontal work surface. The mandrel shall be provided with some convenient means for attaching one end of the wire for wrapping. A suggested method of attachment is the crank arm shown in Fig. 5. The diameter of the round mandrel shall be as specified in the following table. Weights with hooks for attaching to the lower end of the specimens during the mandrel wrap shall be as follows:

| Wire Size, AWG | Mandrel Diameter, |       | Weight, kg (lb.) |       |
|----------------|-------------------|-------|------------------|-------|
|                | mm                | (in.) |                  |       |
| 20             | 13                | (0.5) | 0.7              | (1.5) |
| 14             | 25                | (1.0) | 2.7              | (6.0) |

It is strongly recommended that evaluations be limited to these two conductor sizes. If, however, it is necessary to use other sizes, appropriate mandrel sizes and weights are given in Appendix X1.

14.4.5 Apparatus meeting the requirements of Test Method D 149 shall be provided for performing the voltage withstand test as described in 14.7.4.4.

14.5 Sampling:

14.5.1 Samples shall consist of lengths of wire, preferably with an AWG stranded conductor, having constructions that are considered to be typical and representative of the materials to be tested. Where applicable specifications exist, it should be determined that samples meet these requirements.

14.5.2 Each specimen preferably shall be an insulated wire with an AWG No. 20 stranded conductor; if not, all specimens of a given construction shall have the same conductor size (see

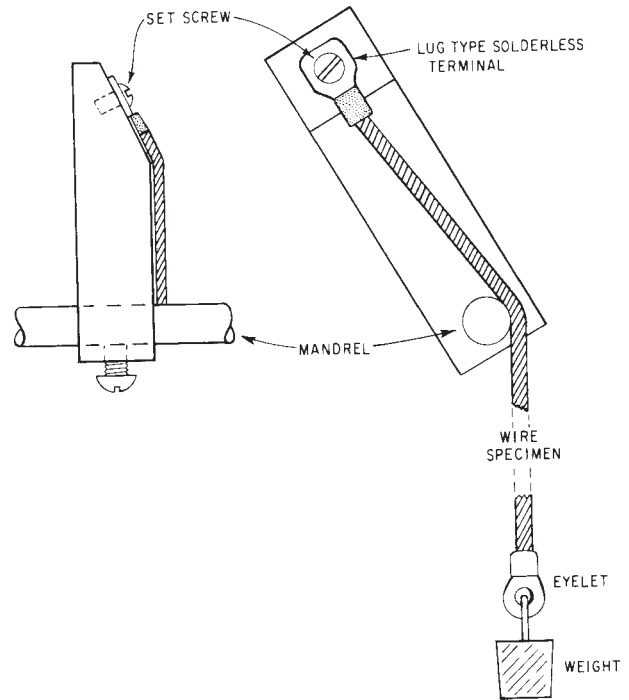

FIG. 5 Method of Attachment of Wire Test Specimen to Mandrel

14.3.1.2). The concentricity should be at least 85 % since, on a mandrel test, strains and the resulting stresses can be excessive and cause premature cracking for an eccentric construction where the thicker section is remote from the mandrel.

14.6 Test Specimens:

14.6.1 The conductor shall be of the construction and materials expected to be used in practice.

14.6.2 Each specimen shall be a 300 to 400-mm (12 to 16-in.) length of wire whose insulation is free of visible imperfections. It is convenient to strip approximately 6 mm (1/4 in.) of insulation at each end and apply a lug from which the weights can be suspended. The lug shall be of a type that not only contacts the conductor but also clamps the insulation to prevent pull-back with temperature exposure. Ten specimens constitute a set for life testing at each temperature. Prepare at least four sets of specimens. Sufficient wire should be on hand for the preparation of eight sets of specimens in case the life at some exposure temperature does not fall within the originally estimated limits.

14.6.3 It is recommended that a control insulated wire construction whose performance is known from laboratory and/or field experience, or both, should be run at the same time. This requires a duplicate number of specimens as described in 14.6.2. Two or more constructions whose performances are not known can be compared and equivalent numbers of specimens will be required for each.

14.7 Procedure:

14.7.1 Qualification of Laboratory Oven:

14.7.1.1 For determination of the temperature index, adjust the oven for 150 ± 10 % air changes per hour. Check out oven performance as described and specified in Specification D 2436.

14.7.1.2 For relative thermal capability, determine the adequacy of the ovens experimentally. Load the ovens with

dummy test specimens that represent the normally expected loading. Attach thermocouples to a minimum of six of the dummy specimens to provide a representative sampling of the work chamber. Preferably temperatures are displayed on a multipoint recorder. Oven adequacy is determined by the temperatures obtained when the oven has stabilized. The average specimen temperature must be within  $\pm 2^\circ\text{C}$  and the maximum instantaneous deviation within  $5^\circ\text{C}$  of the desired operating temperature, regardless of the specimen location. Ovens that do not comply with the requirement may be used provided that one records the actual temperature representative of the specimen exposures. Temperatures shall be recorded, either continuously or at frequent intervals for each sensor location (adjacent to actual specimens). Where temperatures are varying, a time weighted average shall be used with care; if the temperature range averaged is as great as  $10^\circ\text{C}$ , the results are questionable.

**14.7.2 Selection of Temperature for Test**— Select the lowest aging test temperature by adding  $20^\circ\text{C}$  to the temperature index expected at the selected end of life (10 000, 20 000, or 40 000 h). An additional two and preferably three should be selected in  $10$  to  $20^\circ\text{C}$  successive steps. If the log average life at the highest test temperature is found to be less than 100 h, too high a test temperature has been selected and these data should be discarded. Tests should be repeated at a lower temperature. Extrapolation to a temperature index should not exceed  $25^\circ\text{C}$  below the lowest aging test temperature. If extrapolation beyond  $25^\circ\text{C}$  is required, an additional series of tests shall be made at a still lower temperature. If in addition, the average life found at the lowest test temperature is less than 5000 h, tests will be made at lower temperatures until at least 5000 h average life data are achieved.

**14.7.2.1** The average life of the specimens may be affected by the number of cycles. So, to maintain a consistency in the procedure that will assure a reliable degree of reproducibility, make an effort to reach an average of not less than eight and not more than fifteen cycles. A first estimate of cycle time is given in Table 1 of Test Method D 2307. This table provides a selection of the days per cycle and the recommended aging temperatures for wires having thermal index temperatures ranging from 105 to 240. This range could be extended easily if necessary. During the course of the test, increase or decrease the length of the remaining cycles if necessary. A method for making cycle length adjustments is presented in 6.2 of Test Method D 2307.

**14.7.2.2** Make a quick estimation of the highest test temperature by running cycles of approximately one day in length at  $80$  to  $100^\circ\text{C}$  above the nominal rating temperature of the wire or at a point just below the melting point of the primary insulation if it is within this range.

**14.7.2.3** Begin the test sequence with the highest temperatures since exposure times will be relatively short. On the basis of these results, review the proposed lower exposure temperatures and revise if necessary.

**14.7.3** Vertically hang specimens from the mounting rack in the oven using the weights called for in 14.4.4 to keep them straight.

**14.7.4 Inspection Testing:**

**14.7.4.1** Remove the group of specimens from the oven. Allow them to cool to room temperature. Remove the specimens from the rod.

**14.7.4.2** Attach one end of the specimen to the mandrel. Hang the prescribed added weight to its lower end. Rotate the mandrel so that the specimen is wrapped on it, first in one direction and then in the opposite direction. Do this twice. During the wrapping, allow the wire to twist freely and seek its own position on the mandrel with the only limitation that the wire must stay in contact with the mandrel and not wind upon itself. The speed of winding shall be uniform at a rate of one turn in 3 to 5 s. It is preferable to have the winding motorized, but it may be done by hand. Then remove the weights and detach the specimens from the mandrel.

**14.7.4.3** Connect the two ends of a specimen together and immerse the specimen in a room temperature water bath with the ends above the surface, 25 mm (1 in.) of the insulation or jacket being exposed. Soak for 1 h. The bath should contain 1 % of sodium chloride (NaCl).

**14.7.4.4** Apply a 60 Hz 1.5 kV rms withstand test using a rate of rise of 0.5 kV/s. Hold the 1.5 kV for 1 min. If the specimen fails the voltage-withstand test, discontinue the thermal aging on that specimen and record the *total aging* time at that temperature. Failure is defined as drawing in excess of 10 mA per specimen as metered in the high voltage circuit.

**14.7.4.5** Wash the specimens that pass the voltage withstand test in tap water to remove the salt, dry, and replace in the oven as in 14.7.3.

**14.7.4.6** Repeat this procedure until all ten specimens in the group have failed. As an alternate time-saving procedure, the median method for truncating the data may be used. This normally saves one-half to two-thirds of the test time. Here the testing of the group is stopped after the sixth specimen has failed; the testing of the additional unfailed four is discontinued.<sup>14</sup> With the truncated procedure, exposure times are adjusted so that the sixth failure occurs in the fourth to eighth cycle (that is, adjust cycle the same as if all ten specimens were to be tested to failure).

**14.8 Calculation of Results:**

**14.8.1** Calculate the exposure time to failure for each specimen by taking the total test temperature exposure time minus one-half of the exposure time of the last cycle. As an example, suppose a given specimen failed the withstand test following the ninth 100 h exposure. Thus the actual insulation failure occurred at some time between 800 and 900 h. The value to use for calculation is 850 h. The time to be entered on the Arrhenius plot for a given test temperature is the average life of the 10 specimens of the group life tested at that temperature.

$$\text{Average life} = \log^{-1} \left( \frac{\log t_1 + \log t_2 + \log t_3 \dots + \log t_{10}}{10} \right) \quad (5)$$

<sup>14</sup> The testing time can be shortened by statistical methods dealing with truncated data. This is covered in the NRL Report No. 7468 "Statistical Analysis of Truncated-Data Methods to Shorten Thermal-Aging Tests of Electrical Insulation"; L. M. Johnson, F. J. Campbell, and E. L. Brancato, Sept. 19, 1972, Naval Research Laboratory, Washington, DC 20375. Available from the National Technical Information Service, Springfield, VA 22151, as Document No. AD749-925.

where  $t_1, t_2, \dots, t_{10}$  are the successive times to failure of the 10 specimens of that group.

14.8.2 Where truncated data are used:

$$\text{Average life} = \log^{-1} \left( \frac{\log t_5 + \log t_6}{2} \right) \quad (6)$$

Where  $t_5$  and  $t_6$  are the times for the fifth and sixth failures in the succession of failures from the shortest to longer and longer time. The times for specimens one through four do not enter into the calculations.

14.8.3 A complete regression analysis of the life-temperature data can be made by following the statistical procedure in IEEE No. 101A. For an abbreviated method of calculating the regression life line (without confidence limits), the procedure outlined in the appendix of Test Method D 2307 may be used. This is particularly convenient when using the

median method for truncating the data where the average of the log lives ( $L$ ) is determined from only the fifth and sixth failures as described in 14.8.2.

14.9 Interpretation of Results:

14.9.1 The data for thermal life of one insulating system are best presented as an Arrhenius plot where the logarithmic average life (as defined in 14.8.1) is plotted against the reciprocal of the absolute exposure temperature. This usually approximates a straight line but not necessarily so (see Fig. 6).

14.9.2 To compare two insulating systems, a comparison of the Arrhenius plots of the two provides the most useful information.

14.9.3 *Temperature Index, Absolute*—The temperature index is deduced from the Arrhenius plot, at the desired time, preferably 20 000 h and is expressed as follows:

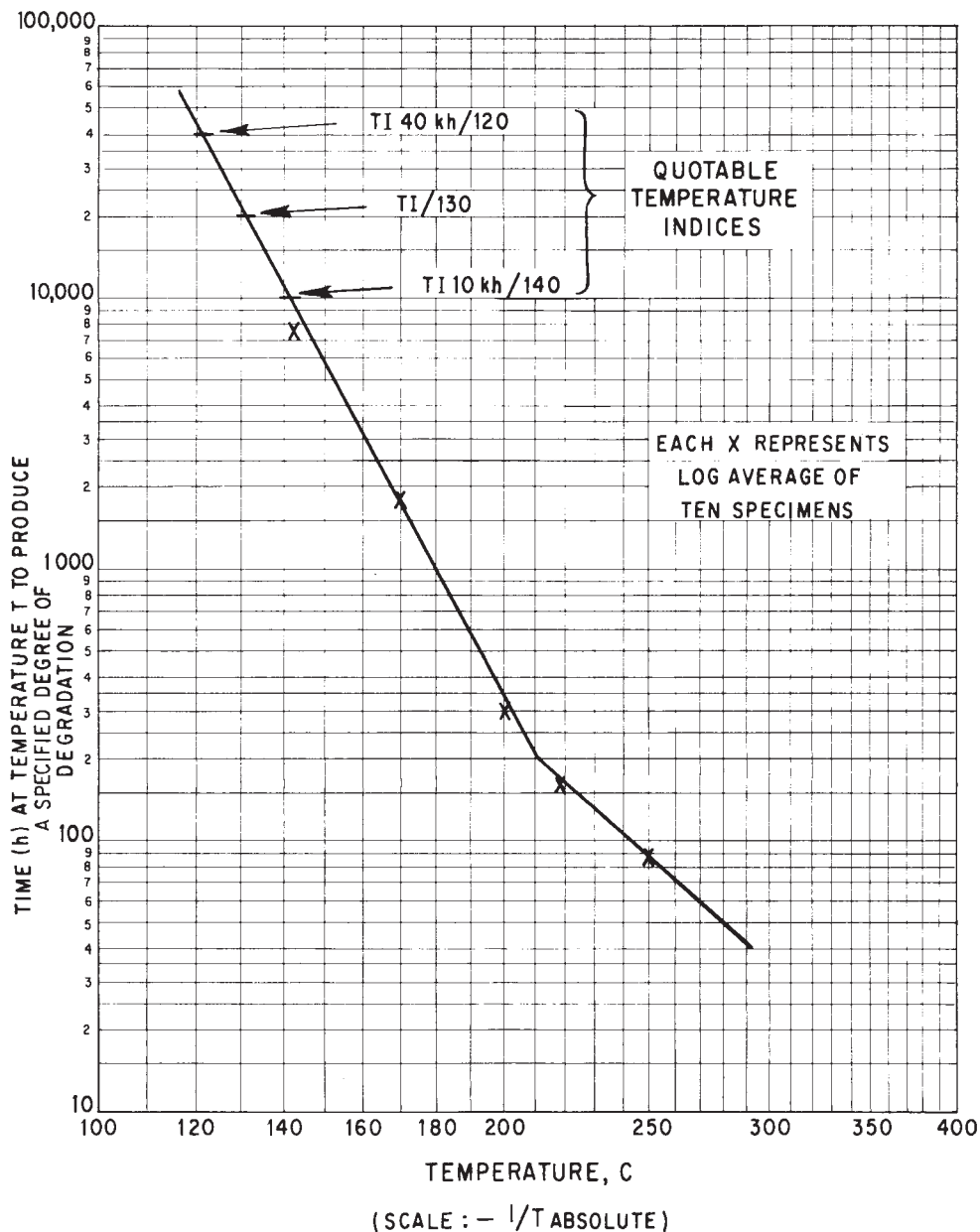

FIG. 6 Model Arrhenius Plot

TI/164 (7)

(meaning that as an example, the 20 000 h life point on the Arrhenius plot came at 164°C). If any other time than 20 000 h is used for the index, the number of thousands of hours so used shall prefix the index. This will be expressed, for example:

TI 5 kh/183 (8)

14.9.4 *Temperature Index, Relative*—When a comparison is made with a standard material (that is, the standard material is run in the same oven at the same time as the test material) plot on the thermal endurance graph both materials on the same sheet, to find the point on the graph for the known material which corresponds to its recognized temperature index and then to use this same time for obtaining the temperature index of the second material. When the temperature index is determined in this way, it is called relative temperature index and is expressed, for example:

RTI/141 (9)

14.9.5 Where the Arrhenius plot is not a straight line but can be fitted by two straight lines of different slopes meeting at a transition temperature, there should be at least three observation points on the line segment at the lower temperature end. If not, an additional life test should be run in this lower temperature region.

14.9.6 If a linear plot with at least 3 points over a range of at least 50°C cannot be obtained, no attempt shall be made to extrapolate the data and only the curve through the actual data points should be reported.

14.10 *Report:*

14.10.1 Report the following information:

14.10.1.1 Complete description of each insulation system with the identity and dimensions of each layer and the dimensions, stranding, and materials and plating of the conductor, and the concentricity of the insulation and coverings,

14.10.1.2 Tabulation of the average and standard deviation for the log-average life at each exposure temperature. It should be stated here whether all specimens were tested to failure or truncated data were used,

14.10.1.3 Graphical presentation of the logarithm of the average life versus the reciprocal of the absolute temperature of exposure for each construction tested,

14.10.1.4 Statement *shall be made* detailing the capability of the oven with a judgement made as to whether the results can be considered as absolute or whether they should be limited to the relative thermal capability of the two or more constructions evaluated, and

14.10.2 Temperature index (or indices) determined (When the oven permits only the relative thermal capability, report the relative temperature index (RTI)).

14.11 *Precision and Bias:*

14.11.1 Because experience has shown that different laboratory ovens rarely give duplicate results on thermal aging tests, it is strongly recommended that this method be limited to evaluation of the relative performance of two or more insulation systems tested at the same time. The procedure can be used in a given laboratory to evaluate a series of materials and arrange them in order of their relative thermal endurance with

a reasonable certainty that another laboratory could arrive at the same relative performance. Numerical limits of precision cannot be set at this time. If an absolute answer is desired, the oven must be made to meet the requirements of Specification D 2436 and the results may still be of very limited accuracy.

**15. Dimensions**

15.1 *Significance and Use:*

15.1.1 The dimensions of an insulated wire or cable are functionally important because the safe operation of the circuit depends on an adequate amount of insulation. Design engineers make use of the dimensions to ensure that adequate space is allowed for the wires and cables in the packaging of the circuit. The accuracy of many test results depends on accurate determination of specimen dimensions. Dimensions form a part of many hookup wire specifications.

15.2 *Apparatus:*

15.2.1 *Micrometer Method*—Micrometers or gages as described in Test Methods D 374 shall be used. A ball foot attached to the micrometer shall be used for concave surface measurements.

15.2.2 *Optical Method*—A microscope or optical comparator equipped with devices capable of making measurements reproducible to at least 0.015 mm or 0.0005 in. shall be used.

15.2.3 Consider the optical method as the referee method in cases of dispute.

15.3 *Test Specimens:*

15.3.1 The specimen shall consist of a length of hookup wire or cable as defined in Section 1 of this method, approximately 660 mm (26 in.) long.

15.4 *Procedure:*

15.4.1 *Insulated Wire, Micrometer Method:*

15.4.1.1 Measure the outside diameter (OD) of the specimen in at least three locations approximately equidistant along the length of the specimen. Each measurement shall consist of two micrometer readings taken at 90° from each other.

15.4.1.2 Remove the insulation without damaging or distorting the conductor. Determine the OD of the conductor in the same manner as used for the OD of the insulation. Use this measurement as the inside diameter (ID) of the insulation.

15.4.1.3 Calculate the wall thickness of the insulation as follows:

$$\text{Wall thickness} = (\text{OD} - \text{ID})/2 \quad (10)$$

where:

OD = average diameter over the insulation, and

ID = average diameter over the conductor.

15.4.2 *Insulated Wire, Optical Method:*

15.4.2.1 Cut a full cross section of the specimen perpendicular to the axis of the wire. It is sometimes necessary to remove the conductor from the specimen before a satisfactory cut can be made.

15.4.2.2 Position the cross section in the optical device and rotate it until the thinnest wall can be measured. Record this thickness as the minimum wall thickness.

15.4.2.3 Move the specimen or the device until the thickest wall can be measured. Record this thickness as the maximal wall thickness.

15.4.2.4 If the specimen has more than one layer of insulation, measure and record the minimum and maximum wall thickness of each layer in accordance with 15.4.2.2 and 15.4.2.3.

15.4.2.5 Measure the OD and the ID of the specimen in three locations approximately 250 mm (10 in.) apart.

15.4.2.6 Calculate the wall thickness from the averages of the above measurements of OD and ID in accordance with 15.4.1.3.

15.4.3 *Cable Jacket, Micrometer Method:*

15.4.3.1 Remove a 400-mm (16-in.) length of jacket by slitting it longitudinally and peeling it from the cable.

15.4.3.2 Measure the jacket thickness, using a ball foot attachment on the concave side of the jacket, in at least three locations. Each measurement shall consist of four readings taken at 90° to each other around the circumference of the cable jacket and approximately equidistant along the length of the specimen.

15.4.3.3 The average of these values shall be the jacket thickness.

15.4.4 *Cable Jacket, Optical Method:*

15.4.4.1 Cut three full cross sections of the jacket perpendicular to the axis of the cable.

15.4.4.2 Position each cross section of the jacket in the optical device and measure the thinnest wall. Make three additional measurements at 90° intervals around the circumference of each specimen. Record these values and report the lowest of the twelve as the minimum wall thickness and likewise the maximum value.

15.4.4.3 Calculate the arithmetic mean of the twelve values and report this value as the average jacket thickness.

15.4.5 *Cable Dimensions, Micrometer Method:*

15.4.5.1 Using a micrometer, measure the OD of the cable at three locations along the length of the cable at the positions shown in Figs. 7-11.

NOTE 13—Due to the large variety of cable configurations, it is impossible to describe each one in this method. Use this section as a guide to the location of measurements on cables not covered.

15.4.5.2 Remove the jacket and make measurements as in 15.4.3 or 15.4.4.

15.4.5.3 On shielded constructions, measure the diameter over the shield at the locations shown in Figs. 7-11.

15.4.5.4 Measure the single components in the cable using the procedures in 15.4.1 or 15.4.2.

15.4.6 *Cable Dimensions, Optical Method:*

15.4.6.1 Cut a full cross section of the cable specimen perpendicular to the axis of wire.

15.4.6.2 Position the cross section of the specimen in the optical device and rotate until the dimensions can be obtained

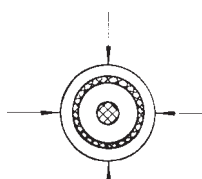

FIG. 7 Single Conductor, Shielded, and Jacketed

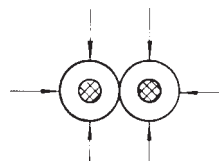

FIG. 8 Unshielded, Twisted Pair

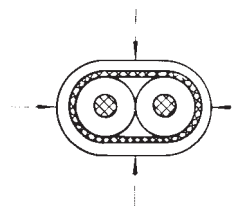

FIG. 9 Shielded and Jacketed Twisted Pair

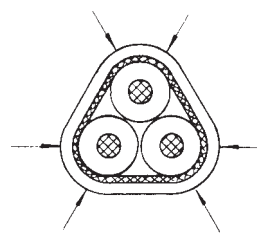

FIG. 10 Shielded and Jacketed Twisted Trio

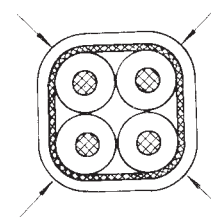

FIG. 11 Shielded and Jacketed Twisted Quad

at the locations shown in Figs. 7-11. Repeat these measurements at three locations along the length of the cable.

15.4.6.3 Measure the single components in the cable using the procedures in 15.4.2.

NOTE 14—For some cables it might be necessary to embed the specimen in a resin and polish the cross section by metallographic methods before accurate dimensions can be obtained. Embedding the specimen becomes mandatory if the optical method is being used as a referee procedure.

15.5 *Report:*

15.5.1 Report the following information:

15.5.1.1 A complete description of the sample including manufacturer's name and part number and any specification number applicable to the material,

15.5.1.2 Type of specimen measured,

15.5.1.3 Method used for making the measurements,

15.5.1.4 A complete listing of the dimensions obtained on the specimen including average, maximum, and minimum values, and

15.5.1.5 The number of places of figures that are to be considered significant in specified limiting values shall be determined by the rounding method in Practice E 29.

15.6 *Precision and Bias:*

15.6.1 These statements are not applicable to these general methods that cover a wide range of insulated hookup-wire types. Optical methods are considered to be more accurate than micrometer methods. Instructions included with most optical equipment can be used for determining the precision and bias of the instrument. Use Test Methods D 374 as a guide to the precision and bias of micrometer methods.

**16. Concentricity**

16.1 *Significance and Use*—The concentricity of hookup wire insulation may be an important factor in the proper operation of a circuit. It is also a measure of workmanship. Many hookup wire specifications include dimensional requirements for conductor and finished wire diameter, but do not specify minimum wall thickness. In such cases, a concentricity requirement will ensure a minimum wall thickness. If conductor diameter, finished wire diameter, and minimum wall thickness are specified, a concentricity requirement may not be necessary.

16.2 *Apparatus*—Use the apparatus as described in 15.2.2 for these tests.

16.3 *Test Specimens*—The same specimens used for dimensions can be used for these tests.

16.4 *Procedure:*

16.4.1 Using the optical methods described in Section 14, locate and measure the wall thickness of the thinnest wall of a cross section of the insulation (Fig. 12 and Fig. 13). The wall thickness shall be the radial distance between the outer rim of the insulation and the outermost strand of the conductor.

16.4.2 Move the specimen or the device until the thickest wall can be measured. Record this thickness.

16.4.3 When the insulation is composed of more than one layer, determine the wall thickness of each layer as well as the entire insulation and calculate the concentricity of each.

16.4.4 The ratio, expressed in percent, of the minimum wall thickness to the maximum wall thickness is the concentricity.

16.5 *Jacket Concentricity*—Determine the concentricity of a cable jacket by the method as described in 16.4.1.

16.6 *Report:*

16.6.1 Report the following information:

16.6.1.1 A complete description of the sample including manufacturer’s name and part number, and any specification number applicable to the material,

16.6.1.2 Type of conductor, and

16.6.1.3 Percent concentricity of the insulation or jacket including the percent concentricity of each layer or multiple layer insulations.

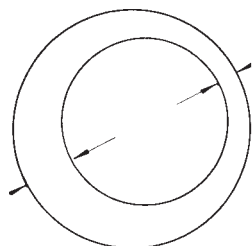

**FIG. 12 Thinnest and Thickest Wall of a Cross Section When the Insulation is Not Below the Conductor Surface**

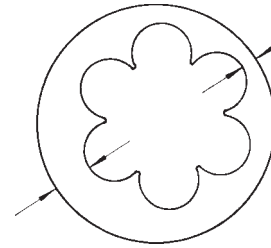

**FIG. 13 Thinnest and Thickest Wall of a Cross Section When the Insulation is Below the Conductor Surface**

16.7 *Precision and Bias*—For the precision and bias of this test method refer to 15.6.

**17. Tensile Properties**

17.1 *Significance and Use:*

17.1.1 This method is designed to produce tensile property data for the control and specification of electrical insulation. These data may also be useful for material specification and qualitative characterization purposes and for research and development of electrical insulation materials. Tensile properties are useful in determining the suitability of the insulation to withstand mechanical stresses to which it may be subjected in use. In addition, the comparison of tensile strength and ultimate elongation before and after exposure to various conditions of accelerated aging or other environmental exposure can be useful in assessing the extent of degradation which may have occurred during the exposure.

17.1.2 Tensile properties may vary with specimen preparation, speed of testing, and environment of testing. Consequently, when precise comparative results are desired, these factors must be carefully controlled.

17.2 *Apparatus*—Use the tension testing apparatus described in Test Method D 638 for this test method.

17.3 *Test Specimens*—Test specimens may be either in the form of tubes or die cut dumbbells. For insulated wire constructions whose conductor is smaller than 12 mm<sup>2</sup>(AWG No. 6) or cable jackets of equivalent diameter and having a wall thickness of 2.3 mm (0.090 in.) or less, the test specimen shall consist of a length of the entire section of the insulation with the conductor removed. For constructions of 12 mm<sup>2</sup>(AWG No. 6) or larger, the insulation or jacket is to be slit lengthwise, laid flat, and die cut using Die C or Die D as described in Fig. 2 of Test Methods D 412. The use of Die C is preferred whenever the sample geometry permits. Die D may be used when the sample is too small or too stiff to make cutting Die C specimens practical. When either the inner or outer surface of the sample is not suitable for test specimens due to imperfections or if the wall thickness is greater than 2.3 mm (0.090 in.), the material shall be buffed in accordance with Practice D 3183 prior to die cutting.

17.3.1 Determine the cross-sectional area of the specimen in accordance with Section 15.

17.3.2 Bench marks for the purpose of measuring elongation shall be placed on each specimen. The marks shall be equidistant from the center of the specimen and perpendicular to its long axis. The marks shall be 25 ± 0.25 mm or 1 ± 0.01 in. apart.

17.4 *Conditioning*—Unless otherwise specified, specimens shall be at a temperature of  $23 \pm 2^\circ\text{C}$  ( $73 \pm 4^\circ\text{F}$ ) at the time of test and shall have been maintained at that temperature for a minimum of 3 h prior to testing. Unless the material being tested is known to be insensitive to moisture, condition a minimum of 24 h at  $23 \pm 2^\circ\text{C}$  and  $50 \pm 5\%$  relative humidity prior to testing.

17.5 *Procedure*—Place the specimen in the jaws of the test machine, taking care to align the specimen along the axis of the applied force. The initial jaw separation shall be  $50 \pm 5$  mm or  $2 \pm 0.2$  in., except when specimens were cut with Die C of Test Methods D 412 when it shall be  $65 \pm 5$  mm or  $2.6 \pm 0.2$  in. The rate of jaw separation shall be as specified in the applicable product specification.

17.5.1 Start the test machine and note the applied force at the specified elongation when the determination of tensile stress is desired. Measure the elongation at rupture to the nearest 10 % and record the applied force to cause rupture of the specimen. Test five specimens.

17.6 *Calculation*:

17.6.1 Tensile stress = observed force at specified elongation/cross-sectional area

17.6.2 Tensile strength = observed force at rupture/cross-sectional area

17.6.3 Ultimate elongation, % =  $[(\text{length between bench marks at rupture in mm} - 25)/25] \times 100$

17.7 *Report*—Report the following information:

17.7.1 Complete identification of the material tested,

17.7.2 Form of test specimen and any special preparation, if used,

17.7.3 Description of special conditioning, if used,

17.7.4 Rate of jaw separation,

17.7.5 Temperature of test if other than  $23 \pm 2^\circ\text{C}$ ,

17.7.6 All observations upon which calculations are based, and

17.7.7 Results as calculated including the arithmetic mean of the five results.

17.8 *Precision*—The precision statement of Test Methods D 412 will also apply to the results obtained with this procedure.

## 18. Flame Tests

18.1 *Scope*:

18.1.1 Two methods are given for flame tests on hookup wire designed for use in transportation vehicle equipment or other end use applications as may be appropriately covered in specification documents.

18.1.2 These test methods are small-scale laboratory procedures for establishing a flammability for hookup wire specimens having conductor sizes equal to or larger than AWG No. 22 and outside diameter below 10 mm.

18.1.3 **CAUTION**—Do not use the results of either of these two test procedures to designate any hookup wire as “flame-resistant,” “fire-proof,” “flame-retardant,” “fire-retardant,” or “fire-resistant.”

18.1.4 This standard should be used to measure and describe the response of materials, products, or assemblies to heat and flame under controlled conditions and should not be used to describe or appraise the fire-hazard or fire-risk of materials,

products, or assemblies under actual fire conditions. However, results of this test may be used as elements of a fire-hazard assessment or a fire-risk assessment which takes into account all of the factors which are pertinent to an assessment of the fire hazard or fire risk of a particular end use.

18.2 *Summary of Test Methods*:

18.2.1 Two methods are described. Method A uses a vertical specimen and a 130 mm flame height; Method B uses a specimen inclined at  $60^\circ$  to the horizontal and a 75 mm flame height. A burner flame, having defined parameters, is applied for a defined period of time. A burn length is measured. Any continuation of flaming after removal of the burner flame is measured by time and the distance of flame travel. Throughout the test, any particles that drip and flame are timed for flame duration. Method A exposes specimens to a more severe flame application to hookup wire specimens than the flame applied by Method B.

18.3 *Significance and Use*:

18.3.1 Test results obtained using either Method A or Method B can be of considerable value in controlling hookup wire manufacturing processes, or as a measure of change or deterioration in burning characteristics after thermal or other environmental exposure. Correlation with flammability under actual use conditions is not implied.

18.3.2 Burn length, rate of burning, and other burning phenomena will vary with material composition, conductor size, and insulation wall thickness. Limit the comparison of test data between insulations only to specimens of the same wall thickness on the same size conductor unless comparison is made on wires intended for the same or similar end use application.

18.3.3 Valid flame test results require that certain variables be arbitrarily fixed, such as specimen size, energy source, time of application of flame, and end points. Among the hundreds of various constructions for hookup wire there are insulation materials which may show variable sensitivity to one or more of the conditions of these methods thus producing variable results. Burning characterization by other standard test methods is desirable in such cases.

18.3.4 These test methods can be used as: a material process control procedure; part of a specification, or an evaluation procedure in comparing or ranking various insulation or jacketing systems.

18.3.5 Criteria established in any specification referencing either of these two test methods should not be construed to represent either an acceptable or an unacceptable level of performance, other than for performance in the specific application described in that particular specification.

18.4 *Interferences*:

18.4.1 The test results (using either Method A or B) can be influenced significantly by air current drafts present in close proximity to the specimen during testing. Results can also be affected by the intensity of incident light within the enclosure which can impair the viewing of any flame.

### Test Method A (vertical 5 inch flame test)

NOTE 15—In Section 18, tolerances for critical dimensions are given. All other dimensions therein are approximate or nominal.

18.5 Apparatus for Method A:

18.5.1 Use an enclosure (fabricated from metal or other inert material which can withstand high temperatures and flaming specimens) having: approximate dimensions of 0.6 m height, 0.3 m width, and 0.3 m depth; open at the top to allow for the safe removal of the products of combustion; and a closable front access door, hinged or sliding, having a glass window for observing the flame application. The inside back and side walls may be painted black to facilitate flame viewing. The chamber requires three draft openings, each approximately 125 mm<sup>2</sup> in area, located in a row, parallel with the lower edge of each of the two side panels, and located 25 mm above the bottom surface of the chamber so as to minimize obstructions to air flow.

18.5.2 Use a Tirrill type burner having a nominal 10 mm internal diameter barrel which has a length of approximately 100 mm above the primary air inlets, and equipped with an adjustment mechanism to produce a 130 mm height flame with a 40 mm height inner cone. For fuel use natural gas at pressure of 1 to 1.5 kPa.

18.5.3 Use a timer graduated to read time intervals as small as 0.1 s.

18.5.4 Use a scale graduated to read to the nearest 1 mm (0.1 in.).

18.5.5 Provide a wedge (see Fig. 14) to tilt the burner 20° from the vertical while keeping the longitudinal axis of the specimen in a vertical plane. Secure the burner to the wedge and place the assembly in an adjustable support jig, so that the jig can be adjusted toward one side or the other of the enclosure to place the longitudinal axis of the barrel in the vertical plane that contains the longitudinal axis of the specimen. The plane is to be parallel to the sides of the enclosure. The jig can also be adjusted toward the rear or front of the enclosure (see Fig. 15), to position the point A, which is the intersection of the longitudinal axis of the barrel, with the plane of the tip of the barrel 45 to 47 mm (1.75 to 1.88 in.) from the point B at which the extended longitudinal axis of the barrel meets the outer surface of the specimen. Point B is the point at which the extension of the tip of the blue inner cone is to touch the center of the front of the specimen. Adjust the assembly so that the specimen is adjusted vertically to prevent point B from being any closer than 75 mm (3 in.) to the lower clamp or other support for the specimen. Point B is also called the test mark.

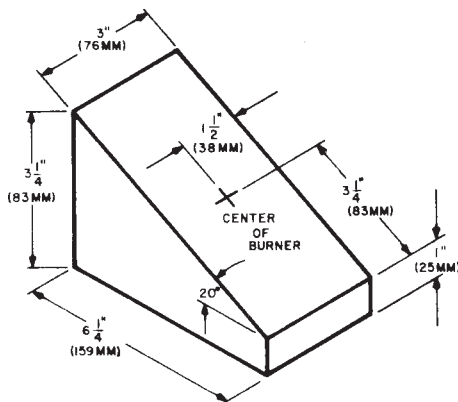

FIG. 14 Wedge Block

18.5.6 For securing specimens in a taut vertical position approximately centered in the test chamber, use screw or tension clamps at the upper and lower specimen ends. The lower clamps shall be compact and designed to afford minimal interference with flaming or dripping particles flowing or falling downward along the vertical wire specimen during the flame test. The lower clamp must neither bar nor deflect downward flowing or dripping material from contact with the cotton layer placed on the chamber floor.

18.5.7 Use a surgical grade cotton on the chamber floor to catch particles that drip from the wire specimen during burning. Store this cotton in a controlled environment of 23 ± 2°C and 50 ± 5 % relative humidity for at least 24 h prior to use.

18.6 Sampling, Test Specimens, and Tests Units:

18.6.1 Take samples of hookup wire or cable in a random manner. Unless otherwise specified, obtain lengths of wire sufficient to make at least five test specimens for each hookup wire type, size, or construction.

18.7 Conditioning:

18.7.1 Condition all test specimens in air at 23 ± 2°C and 50 ± 5 % relative humidity for at least 24 h prior to testing.

18.8 Procedure for Method A: **CAUTION**—The products of combustion produced by this test method may be toxic. Perform all tests within a laboratory fume hood equipped with approved means for exhausting gaseous products safely and in accordance with environmental regulations.

18.8.1 From the sample of 18.6, cut specimens of hookup wire which are approximately 0.6 m in length.

18.8.2 To each specimen, attach an indicator flag, consisting of a strip of gummed kraft paper 0.13 mm (0.005 in.) nominal thickness and 13 mm (0.5 in.) width. The paper is known in the trade as 60-lb. stock and is an adhesive coated paper substantially the same as that described as Type III, Grade B in Federal Specification PPP-T-45C.

18.8.3 Secure the specimen in a taut, vertical position approximately centered in the test chamber, using screw or tension clamps in accordance with 18.5.6.

18.8.4 Make tests in a room generally free of drafts of air. Use a ventilated hood if it can be demonstrated that air currents do not affect the test flame. Clamp a test specimen so that it is vertical and taut. Apply a paper indicator to the specimen so that its lower edge is 250 ± 5 mm (10 ± 0.2 in.) above the point at which the extended axis of the burner stem, with the burner properly located, intersects the specimen surface (see Fig. 15). Wrap the indicator once around the specimen with the gummed side toward the conductor and the ends pasted evenly together and projecting 20 ± 2 mm (0.75 ± 0.08 in.) from the wire on the opposite side of the specimen from where the test flame is applied. Moisten the gummed surface of the paper tab only to the extent that will permit proper adhesion.

18.8.5 Position a flat horizontal layer of untreated surgical grade cotton 5 to 25 mm (0.25 to 1 in.) thick at the bottom of the chamber under the test specimen. The upper surface of the cotton shall not be more than 240 mm (9.5 in.) below the point of impingement of the test flame. Make the area of the cotton large enough to encompass any flaming, dripping particles but not so large as to obstruct free air flow through the chamber.

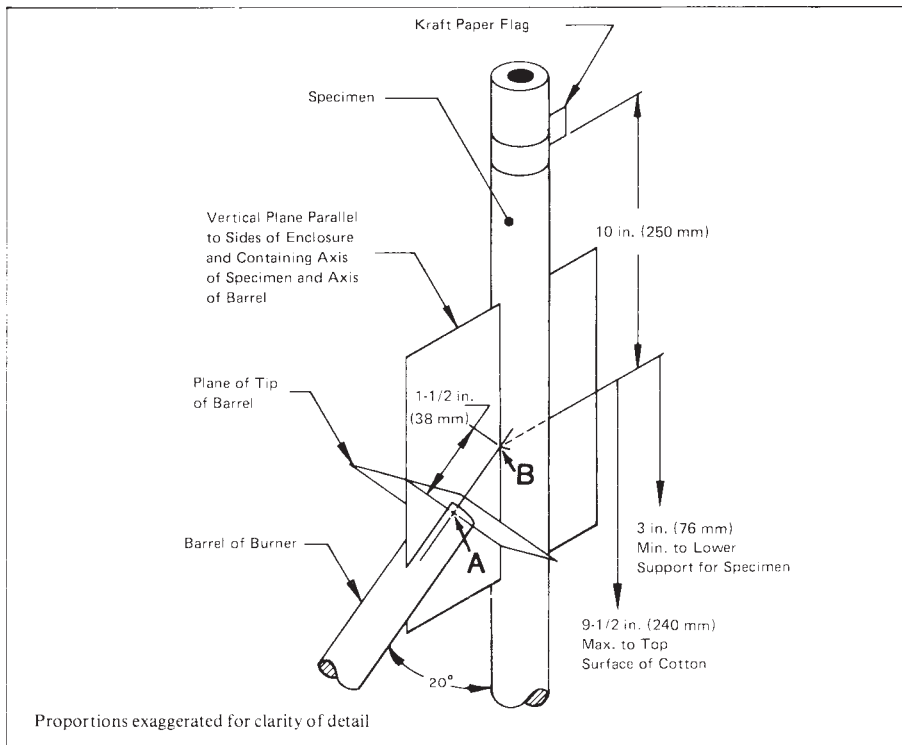

Essential Dimensions For Vertical Wire Flame Test.

FIG. 15 Diagram of Burner Position

Place a layer of cotton 5 to 25 mm (0.25 to 1 in.) thick on the wedge and around the base of the burner.

18.8.6 If the burner has a gas pilot light, open the valve supplying gas to the pilot and light the burner. If the burner does not have a gas pilot, position that burner at least 150 mm (6 in.) from the specimen and then light the burner. With the burner in a vertical position, adjust the height of the flame, by means of the main supply valve, to approximately 130 mm (5 in.) with an inner cone 40 mm (1.5 in.) in height. Conduct this operation and the remainder of the test in a place having adequate ventilation for removal of smoke and fumes, but avoiding drafts that affect the flame.

18.8.7 If the burner has a gas pilot light, open the valve supplying gas to the burner to apply the flame to the specimen automatically. If the burner does not have a gas pilot light, move the burner into position to apply the gas flame to the specimen.

18.8.8 After 15 s of flame application to the specimen, remove the flame source from the specimen and start the timer. Either turn the burner off or rotate the wedge/burner assembly so that the flame is not being applied to the specimen.

18.8.8.1 Stop the timer when the specimen stops burning. Record this burn time.

18.8.8.2 If the specimen has stopped burning, wait 15 s, then reapply the flame.

18.8.8.3 If the specimen continues to burn after 15 s, wait until burning stops of its own accord before reapplying the flame. Record the burn time.

18.8.8.4 Repeat this cycle four times for a total of five applications of 15 second flame.

18.8.9 After the fifth application of flame on each specimen, and after the burning has stopped, cool the specimen and measure the burn length to the nearest 1 mm (0.1 in.).

18.8.9.1 The burn length is a distance along the specimen length between the original location of the test mark (Point B on Fig. 15) and a location above Point B farthest from that test mark which shows evidence of damage due to flaming. The burn length may include that portion of the specimen below Point B which has burned as a result of flame application.

18.8.9.2 Include in the distance any specimen area which is charred, embrittled, or shows evidence of partial combustion.

18.8.9.3 Exclude from the distance any specimen area which is sooted, warped, stained, or discolored.

18.8.9.4 Exclude from the distance any specimen area where insulation or jacket material has shrunk or melted away as a result of exposure to heat.

18.8.9.5 Record the burn length for each specimen.

18.8.10 Test at least five specimens.

18.8.10.1 Using the burn length for each of at least five specimens, calculate an arithmetic average. Round that average upward to the next whole number of millimetres (or 0.1 inches) and record that number, and its units, as the flame test value for the material.

18.9 Report:

18.9.1 Report the following information for each wire type, size, or construction:

18.9.1.1 A complete description of the sample wire or cable including conductor gage size, number of strands, gage size of strands and strand material, plating, generic name of material (or materials for multilayer constructions), manufacturer's

name and part number, specification number, and insulation thickness (each layer for multilayer constructions),

18.9.1.2 The flame test value in accordance with 18.8.10.1,

18.9.1.3 Burn time in seconds after each application of test flame,

18.9.1.4 The number of specimens tested,

18.9.1.5 Whether or not the cotton was ignited after each application of flame,

18.9.1.6 The condition of the paper flag as a percent burned after each application of flame,

18.9.1.7 Name and location of laboratory doing test.

18.10 Precision and Bias:

18.10.1 Five sets of specimens were prepared for this study. Testing was performed in four laboratories. Summary data are given in Appendix X3. Note that the data in Appendix X3 do not include a burn length value in accordance with 18.8.10.1.

18.10.2 Pass or fail criteria are not a part of this test method. It would be appropriate to include criteria in specifications using this method. Using criteria typically applied to this method, agreement was found in 19 out of 20 cases.

18.10.3 No statement is made about either the precision or the bias of the vertical flame test method, since the result merely states whether there is conformance to the criteria for success specified in the procedure.

Test Method B (inclined 3 inch flame test)

18.11 Apparatus for Method B:

18.11.1 Use the enclosure described in 18.5.1.

18.11.2 Use a Tirrill type burner, having a nominal 10-mm internal diameter barrel which has a length of approximately 100 mm above the primary air inlets, and equipped with an adjustment mechanism to produce a 75-mm height flame with a 25-mm height inner cone. Use methane gas of 99 % minimum purity as fuel. Use of a Bunsen type burner is also permitted.

18.11.3 A fixture for mounting the burner is recommended for easily moving the burner into and out of the test position as prescribed in the procedure section.

18.11.4 Use a timer graduated to read time intervals as small as 0.1 s.

18.11.5 Use a scale graduated to read to the nearest 1 mm (0.1 in.).

18.11.6 Use a clamp, a 50 to 75-mm diameter sheave, and a weight for securing the specimen in a taut, inclined position appropriately located in the test chamber. Secure the clamp in the lower left portion of the enclosure at least 150 mm from the front of the enclosure. Secure the sheave in the upper right portion of the enclosure, at least 150 mm from the front, and aligned with the center of the clamp so that a wire specimen can be positioned over the sheave and clamped so that the specimen is at approximately 60° to the horizontal. Position the sheave and the clamp so that a span of at least 0.6 m is maintained between the clamp and the periphery of the sheave. See Fig. 16 and Fig. 17 for relative positioning.

18.12 Sampling, Test Specimens, and Test Units:

18.12.1 Take samples of hookup wire or cable in a random manner. Unless otherwise specified, obtain lengths of wire sufficient to make at least five test specimens for each hookup wire type, size, or construction.

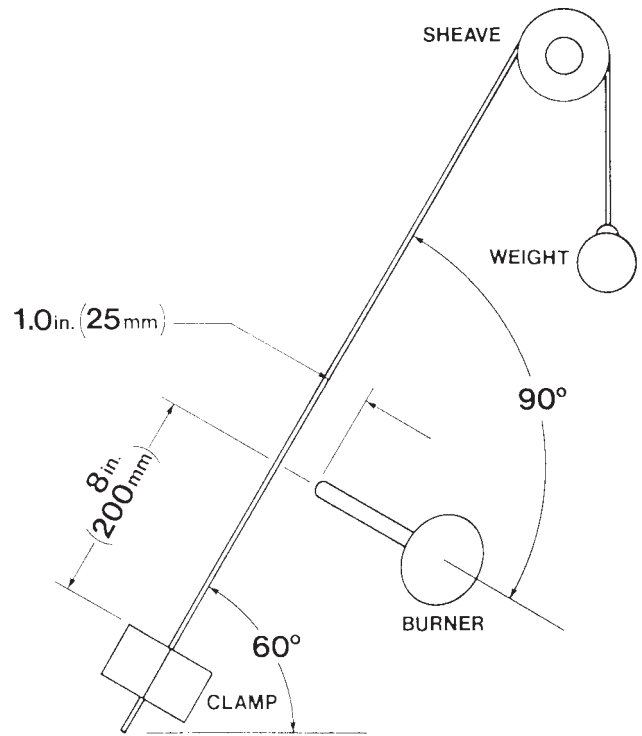

FIG. 16 Relative Position of the Burner and Specimen as Viewed From the Front of the Enclosure

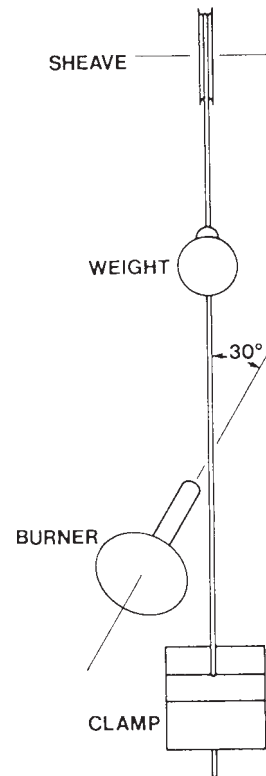

FIG. 17 Relative Positions of Burner and Specimen as Viewed as From the Right Side of the Enclosure

18.13 Conditioning:

18.13.1 Condition all test specimens in air at  $21 \pm 3^\circ\text{C}$  and  $50 \pm 5\%$  relative humidity for at least 24 h prior to testing.

18.14 *Procedure for Method B: CAUTION*—The products of combustion produced by this test method may be toxic. Perform all tests within a laboratory fume hood equipped with approved means for exhausting gaseous products safely and in accordance with environmental regulations.

18.14.1 From the conditioned sample of 18.13, cut wire or cable specimens approximately 0.8 m in length.

18.14.2 Position the enclosure in the fume hood so that the interior of the enclosure remains essentially draft free.

18.14.3 Secure one end of a specimen in the clamp. Attach a weight to the other end of the wire specimen to keep the inclined specimen taut. The weight need be only heavy enough to maintain tautness. Light weights are used for small diameter and flexible wire or cable specimens; heavier weights are required for stiffer or larger diameter specimens.

18.14.3.1 Place the specimen over the sheave. Be sure the specimen is taut and that the specimen is approximately 60 degrees to the horizontal. Place a test mark on the specimen at an approximate distance of 200 mm from the clamp edge. The test mark is the point at which the burner flame is aimed (see Fig. 16).

18.14.4 Consult the applicable specification for the specified time of burner flame application.

18.14.5 With the burner in a vertical position and at least 150 mm away from the test position, adjust the burner flame to 75 mm height with an inner cone height of 25 mm.

18.14.6 Position the barrel of the burner 90° to the specimen length direction when viewed from the front of the enclosure, and at 30° to the vertical plane in which the specimen is located. Positioning the burner is best accomplished by use of a positioning device which can be easily rotated to meet the requirements of 18.11.3, Fig. 16, and Fig. 17.

18.14.7 Start a timer when the inner cone tip of the burner flame contacts the test mark. Maintain the burner flame at the test mark for the specified time of application mandated by the specification. If a specified time is lacking, use a flame application time of 15 s.

18.14.8 At the end of the flame application time, move the burner flame so that it is at least 150 mm from the original location of the test mark and from any other portion of the specimen.

18.14.9 Record the time when any visible flaming of the specimen ceases.

18.14.10 If any flaming, dripping particles fall to the floor of the enclosure and continue to burn after the flaming of the specimen ceases, record such burning time.

18.14.11 Stop the timer when all burning and flaming ceases. Record this total time to the nearest 0.2 s.

18.14.12 The time of afterburn is the time observed from 18.14.10 minus the specified time of burner flame application. Record the afterburn time.

18.14.13 Allow the specimen to cool, then measure the burn length to the nearest 1.0 mm (0.1 in.).

18.14.14 The burn length is the distance along the specimen between the original location of the test mark and a location farthest from that test mark which shows evidence of damage due to flaming. Include in the distance any specimen area which is charred, embrittled, or shows evidence of partial combustion. Exclude from the distance any specimen area which is sooted, warped, stained, or discolored. Exclude from the distance any specimen area where insulation or jacket material has shrunk or melted away as a result of exposure to heat.

18.14.15 Using the burn length for each of at least five specimens, calculate an arithmetic average. Round that average upward to the next whole number of millimetres (or 0.1 inches) and record that number, and its units, as the flame test value for the material.

**18.15 Report:**

18.15.1 Report the following information for each wire type, size, or construction:

18.15.1.1 A complete description of the sample wire or cable including conductor gage size, number of strands, gage size of strands and strand material, plating, generic name of material (or materials for multilayer constructions), manufacturer’s name and part number, specification number, and insulation thickness (each layer for multilayer constructions),

18.15.1.2 The flame test value in accordance with 18.14.15,

18.15.1.3 Flame application time used, in seconds,

18.15.1.4 The number of specimens tested,

18.15.1.5 The longest burn length distance measured, with units,

18.15.1.6 The longest time of afterburn, if any,

18.15.1.7 The longest burn time of flaming, dripping particles, if any,

18.15.1.8 Name and location of laboratory doing test.

**18.16 Precision and Bias:**

18.16.1 *Precision*—The values in Table 1 and Table 2 were calculated from the results obtained when seven wire samples were tested by six laboratories in a round-robin study.<sup>15</sup>

18.16.2 The precision data in those tables are expressed as a percentage of either the average burn length or the average

<sup>15</sup> Supporting data are available from ASTM Headquarters. Request RR: F 07–1001.

**TABLE 1 Precision Statements-Afterburn Time**

| Sample Tested        |                                       | Overall Average Values, s | Repeatability Coefficient of Variation, % | Reproducibility Coefficient of Variation, % |
|----------------------|---------------------------------------|---------------------------|---|---|
| Conductor Size (AWG) | Insulation Type                       |                           |   |   |
| 20                   | ETFE (ethylene & tetrafluoroethylene) | 0.0                       | ...                                       | ...   |
| 12                   | ETFE                                  | 0.9                       | 33  | 91  |
| 20                   | Polyolefin/ETFE                       | 28.7                      | 97  | 108   |
| 20                   | Flame Retarded Polyolefin             | 30.8                      | 100                                       | 122   |
| 20                   | PVC/Polyamide                         | 3.2                       | 97  | 150   |
| 10                   | Polyolefin                            | >120 <sup>A</sup>         | ...                                       | ...   |
| 12                   | PVC/Polyamide                         | 33.3                      | 121                                       | 121   |

<sup>A</sup>All specimens were completely consumed.

**TABLE 2 Precision Statements—Burn Length**

| Sample Tested        |                                       | Overall Average Values,<br>in. | Repeatability Coefficient<br>of Variation, % | Reproducibility Coefficient<br>of Variation, % |
|----------------------|---------------------------------------|--------------------------------|--|--|
| Conductor Size (AWG) | Insulation Type                       |                                |  |  |
| 20                   | ETFE (ethylene & tetrafluoroethylene) | 1.34                           | 8  | 23   |
| 12                   | ETFE                                  | 1.02                           | 8  | 23   |
| 20                   | Polyolefin/ETFE                       | 2.37                           | 39   | 54   |
| 20                   | Flame Retarded Polyolefin             | 3.21                           | 60   | 76   |
| 20                   | PVC/Polyamide                         | 1.76                           | 14   | 29   |
| 10                   | Polyolefin                            | A                              | ...  | ...  |
| 12                   | PVC/Polyamide                         | 3.43                           | 74   | 77   |

<sup>A</sup>All specimens were completely consumed.

afterburn time based on three specimens per sample. Notice that the information in Table 1 and Table 2 does not include a flame test value in accordance with 18.14.15.

18.16.3 The coefficients of variation are the ratios of the standard deviations “within laboratory” (repeatability) or “between laboratories” (reproducibility) expressed as a percentage of the overall average values.

18.16.4 *Bias*—No useful analysis of bias is possible for this test method because there is no standard reference material with which results can be compared.

### 19. Bondability of Insulation to Potting Compounds

19.1 *Significance and Use*—A measure of the bonding between potting compounds and hookup wire insulation is useful in assessing the effectiveness of the system in contributing to the support and protection of electrical terminations.

#### 19.2 Apparatus:

19.2.1 Use the apparatus described in Test Method D 638.

19.2.2 Molds for containing the wire specimen and potting compound shall have a cup-like configuration with an internal diameter of at least 12 mm (0.5 in.) and an internal depth of at least 25 mm (1.0 in.). Provide a hole in the bottom center of the mold slightly larger than the outside diameter of the insulated wire so that the specimen protrudes through the mold bottom during potting.

NOTE 16—Disposable plastic beakers or vials have been found suitable for this purpose.

19.2.3 Use equipment recommended by the wire or potting compound manufacturer for preparing the surface of the wire insulation and for mixing, preparing, and applying the potting compound.

#### 19.3 Test Specimens:

19.3.1 Specimens shall consist of straight lengths of insulated hookup wire approximately 300 mm (12 in.) long having no knots, kinks, twists, or other irregularities.

19.3.2 Test at least five specimens.

#### 19.4 Procedure:

19.4.1 Measure the outside diameter of the specimen to the nearest 0.025 mm (0.001 in.) using the methods described in the section on Dimensions.

19.4.2 Clean at least 37 mm (1.5 in.) of the prepared end in accordance with the instructions of the wire or potting compound manufacturer. If primer is used, follow the recommendations for its use. Do not touch the prepared end of the specimen or allow it to become contaminated.

19.4.3 Insert the prepared end of the specimen through the hole in the bottom of the mold. A clamping device is recom-

mended to hold the specimen in a vertical position. Putty or clay can be used to seal the hole in the mold.

19.4.4 Prepare the potting compound in accordance with the manufacturer’s instructions.

19.4.5 Introduce the prepared potting compound into the mold so that the insulated wire is embedded for a length of approximately 25 mm (1 in.). Avoid the introduction of air bubbles into the potting compound.

19.4.6 Follow the manufacturer’s instructions for curing the potting compound.

19.4.7 Measure the depth of the potting compound in contact with the insulation to the nearest 1.5 mm (0.060 in.).

19.4.8 Remove putty or clay from the bottom of the mold.

19.4.9 Hold the molded section of the specimen by passing the unpotted end of the wire through a plate having a hole in it approximately twice the diameter of the insulated wire. Hold the plate in one jaw and securely fasten the unpotted end of the specimen to the other jaw of the testing machine. Using the apparatus of 19.2.1, measure to the nearest 0.5 N (0.1 lbf) the maximum force required to pull each wire specimen from the potting compound using a crosshead speed of 25 mm/min (1.0 in./min.). The force shall be applied in line with the specimen perpendicular to the surface of the potting compound.

19.4.10 Visually examine the specimen and determine the failure mode of the bond, that is, adhesive failure between the insulation and the potting compound, cohesive failure of the potting compound, tensile failure of the insulation allowing the conductor to pull out or separation of dual-layered insulation systems. Estimate the percentage ( $\pm 10\%$ ) of each mode of failure if more than one is found.

19.5 *Calculation*—Calculate the pull-out strength in megapascals (or pounds-force per square inch) of insulation surface as follows:

$$\text{Pull-out strength} = \frac{\text{force, max}}{\text{depth} \times \text{OD} \times \pi} \quad (11)$$

where:

- force, max = maximum force required to pull the specimen from the potting compound, N (or lbf),
- depth = length of insulated wire in the potting compound, mm (or in.), and
- OD = outside diameter of the insulated wire, mm (or in.).

#### 19.6 Report:

19.6.1 Report the following information:

19.6.1.1 Detailed description of the insulated wire including the outside diameter,

19.6.1.2 Description of the potting compound and primer if applicable,

19.6.1.3 Description of the surface preparation of the insulated wire, preparation of the potting compound and curing conditions of the potted specimens,

19.6.1.4 Length of the insulated wire in the potting compound,

19.6.1.5 Mode of failure and percentage of each if more than one mode is found,

19.6.1.6 Maximum pull-out force of each specimen, and

19.6.1.7 Calculated pull-out strength of each specimen.

19.7 *Precision and Bias:*

19.7.1 Data from an interlaboratory study of the method are available as RR:D09-1009.<sup>15</sup>

19.7.1.1 Eight sets of specimens were prepared for this study. Testing was performed by six laboratories. Summary pull-out strength data, including standard deviation and coefficient of variation, from all laboratories on all materials are given in Appendix X2. Pull-out strength data on specimens made from the same materials by two laboratories and tested by all laboratories are also given in Appendix X2.

19.7.1.2 The maximum coefficient of variation found in the pull-out strength test was 29.7 % when data from all laboratories on all materials were analyzed.

19.7.1.3 Samples made from the same insulated wire and potting compound in two laboratories gave a maximum coefficient of variation of 30.7 % when tested by all laboratories.

19.7.2 No justifiable statement on the accuracy of this method can be made since the true value of the property cannot be established by an accepted referee method.

## 20. Crush Resistance

20.1 *Significance and Use:*

20.1.1 The crush resistance test method measures the ability of a wire insulation to withstand a load applied through a flat or round surface. It simulates the damage that may occur when an insulated wire is crushed between two opposing surfaces that are free of sharp edges. The test may be performed at elevated temperatures if the evaluation of that environmental condition is desired. Comparison of results on different insulation systems is most useful.

20.1.2 Wire construction variables may have a pronounced effect on crush resistance. These include gage size of conductor, wall thickness and concentricity of insulation, multilayer insulation systems and conductor construction. A stranded conductor has the ability to flatten under load more easily than solid conductor thereby distributing the load more favorably. In addition, the number of strands and type of stranding can be a variable in crush resistance, therefore comparative testing on different insulation systems should be done on specimens whose conductor size and stranding are identical.

20.1.3 When this method is used for specification purposes, the specific loading surface and the test temperature must be stated in the specification.

20.2 *Apparatus:*

20.2.1 *Test Machine*—Use a universal tensile test machine as described in Test Method D 638. The machine shall be suitably equipped to operate in a compression mode. In addition it shall be provided with a 12V ac or dc detection

circuit which will sense the contact of the loading surface with the metallic conductor and stop the cross-head travel. The testing machine shall be equipped with a recorder which will permit determination of the maximum force encountered during the test. When required, the machine shall be equipped with an environmental chamber capable of maintaining temperature within  $\pm 2^{\circ}\text{C}$  ( $\pm 4^{\circ}\text{F}$ ).

20.2.2 *Loading Surfaces*—The crush force shall be applied through either a flat steel plate  $50 \pm 1$  mm ( $1.97 \pm 0.04$  in.) square or a cylindrical hardened steel mandrel as described below. The plate or mandrel shall be attached to the cross-head of the testing machine such that the plate surface or the long axis of the mandrel is parallel to the support anvil.

| Wire Conductor Size, AWG | Mandrel Diameter ( $\pm 5\%$ )   |
|--------------------------|--|
| larger than 12           | equal to specimen OD   |
| 12 to 16                 | 2 mm (0.08 in.)  |
| 18                       | 1 mm (0.04 in.)  |
| 20 and smaller           | 0.635 mm (0.025 in.), except where insulation exceeds 0.635 wall thickness. In this case use diameter equal to wall thickness. |

20.2.3 *Support Anvil*—The specimen support shall be a flat metal surface larger than 50 mm square which will hold the specimen in opposition to the loading surface. All corners of the support shall be broken to minimize edge effects.

20.3 *Test Specimen*—The test specimen shall be a single 600-mm (24-in.) length of insulated wire. Remove sufficient insulation from one end of the specimen for connection to the detection circuit. Measure wall thickness and determine concentricity in accordance with Sections 15 and 16 of these methods.

20.4 *Conditioning:*

20.4.1 Unless otherwise specified, the test specimens and the test apparatus, particularly the support anvil and the loading surface, shall be at a temperature of  $23 \pm 2^{\circ}\text{C}$  ( $73 \pm 4^{\circ}\text{F}$ ) at the time of test and shall have been maintained at that temperature for a minimum of 3 h prior to testing.

20.4.2 When performing tests at elevated temperature, the specimen and the test apparatus shall be stabilized at the desired temperature  $\pm 2^{\circ}\text{C}$  ( $\pm 4^{\circ}\text{F}$ ) prior to each individual test. This may require up to 1 h depending on chamber and specimen size.

20.5 *Procedure:*

20.5.1 Place the specimen on the support anvil oriented perpendicular to the mandrel axis when a mandrel is used. Connect the detection circuit. Force the loading surface against the insulation at a constant rate of 5 mm (0.2 in.) per minute until contact with the conductor occurs.

20.5.2 Perform eight tests on each specimen with the specimen being moved forward 25 mm (1 in.) minimum when a mandrel is used and 63 mm (2.5 in.) minimum when a flat plate is used, and rotated  $90^{\circ}$  always in the same direction before subsequent tests. The crush resistance shall be the arithmetic mean of the eight test result values. Record the maximum force indicated during each test.

20.6 *Report:*

20.6.1 Report the following information:

20.6.2 Complete description of the wire construction tested including dimensions and concentricity,

20.6.3 Temperature of test if other than  $23 \pm 2^{\circ}\text{C}$ ,

20.6.4 Description of loading surface including shape and dimensions, and

20.6.5 Individual values and arithmetic mean of the eight test results.

20.7 *Precision and Bias:*

20.7.1 Five types of insulated hookup wire were tested in three laboratories and the results of the tests are given in the Research Report.<sup>16</sup> Because the precision is dependent on the sample tested—its quality, concentricity and type of conductor stranding—it is not possible to make a definitive precision statement. The coefficient of variation between the three laboratories that reported was high. The concentricity of the insulated wires tested was also quite poor, but not unrealistic of that expected in commerce. The user is especially cautioned that due to the necessarily small contact area to the tested wires in this procedure, what seems to be insignificant deviations from dimensions, force application, speed and parallelism or right-angleness of equipment can substantively affect the precision of this method. A 2x to 3x spread of data is not uncommon. See the Research Report for examples of data obtained from typical wire constructions.

20.7.2 A statement of bias is not possible due to the lack of a standard reference material.

## 21. Axial Stability (Longitudinal Change) After Thermal Exposure

21.1 *Scope:*

21.1.1 This test method covers the evaluation of short term severe thermal stress on round wire insulation and cable jackets with respect to their dimensional stability. This method applies to electrical insulation of different wall thicknesses applied to wire of various gages, and includes insulations and jackets having multiple layers as primary insulation and insulating jackets. It also applies to single and multicomponent cable jackets.

21.2 *Significance and Use*—Under certain conditions, such as conductor current overload, wire insulations can become abnormally hot for short periods of time while in a physically stressed state, and then rapidly cool when the current is reduced. Also, events exist where wires can be operated at normal service temperatures then quickly be subjected to low temperatures. The shrink back or expansion test serves as a means to determine the stability of an electrical insulation prior to being specified or put into service under such conditions. It is also a means for determining residual stresses that could occur in the manufacture of insulated wire. The test temperature may affect results, for example, stress built-in during manufacturing may or may not be relaxed depending on the test temperature.

21.3 *Apparatus:*

21.3.1 *Oven Test Chamber*, as described in Specification D 2436.

21.3.2 *Wire Handling Screen*, large enough to support the entire length of wire specimen. The mesh should be large enough to permit good air circulation and consist of a noncorrosive metal.

21.3.3 *Cold Chamber*, designed to maintain the desired temperature to  $\pm 2^\circ\text{C}$ , as described in Practice D 618.

21.3.4 *Measuring Equipment*, such as a machinist rule capable of measuring 0.4 or 0.25 mm (0.16 or 0.10 in.) or a microscope capable of measuring to 0.25 mm (0.10 in.). Consider the microscope method as the referee method in cases of dispute.

21.4 *Test Specimens:*

21.4.1 Prepare a specimen of wire or cable, 0.36 m (14 in.) long by cutting each end such that conductor and insulation are square with the longitudinal axis. Remove approximately 25 mm (1 in.) of insulation from each end of the wire. Use care that the conductor metal is not burred so as to hinder any longitudinal movement of the insulation. The insulation is defined as all layers of nonconducting material covering the electrical conductor including: primary insulation, all tapes, braids, and the jacket. Place the straight specimen on a wire screen for handling throughout the test.

21.4.2 Measure the distance from the end of the insulation to the end of the conductor to the nearest 0.250 mm (0.010 in.).

21.5 *Procedure*—Place the specimen in a preheated air circulating oven at the temperature specified, for the period of time required for the specimen to reach thermal equilibrium. The time mainly depends on the desired temperature and the mass of the wire tested. In the event no temperature is so specified, bring the oven up to the rated temperature of the insulated wire. Remove the specimen from the oven and, within two minutes, place it in a chamber which has been precooled to the lowest rated temperature, unless otherwise specified. Expose the specimen to this temperature for the period of time required for it to reach this temperature, after which remove and allow the specimen to return to room temperature,  $20^\circ\text{C}$  to  $25^\circ\text{C}$  ( $68^\circ\text{F}$  to  $77^\circ\text{F}$ ). At the conclusion of this cycle, measure to the nearest 0.250 mm (0.010 in.) the distance from the end of each layer of insulation to the end of the conductor at both ends as either shrinkback or expansion. Repeat this thermal exposure cycle and the measurements for an additional three times for each specimen, for a total of four times.

21.6 *Report:*

21.6.1 Report the following information:

21.6.2 Number of specimens tested,

21.6.3 Description of the wire specimen, including number of insulating layers, types of materials (both insulation and conductor), conductor gage and stranding, and wall thickness,

21.6.4 Length of specimen,

21.6.5 Distance from end of each layer to the end of the conductor at each end of the wire after conclusion of each thermal shock cycle,

21.6.6 Flaring of any layer,

21.6.7 Oven temperature used,

21.6.8 Cold temperature used, and

21.6.9 Period of exposure at high and low temperatures.

21.7 *Precision and Bias*—No data are available to predict the precision expected in laboratory tests. They are under development at this time.

## 22. Dynamic Cut-Through

22.1 *Significance and Use:*

<sup>16</sup> Supporting data are available from ASTM Headquarters. Request RR: D 09-1021.

22.1.1 The dynamic cut-through test measures the resistance of a wire insulation to the penetration of a cutting surface and simulates the type of damage that may occur when a wire is forced by mechanical loading against a sharp edge. The test may be performed at elevated temperatures to evaluate this effect on the insulation performance. Comparison of results on different insulation systems is useful but test conditions may not necessarily relate to actual installations and therefore should only be used in a general way for design purposes. This method is limited to specimens with insulation wall thicknesses not exceeding 0.38 mm (0.015 in.).

22.1.2 Wire construction variables may have a pronounced effect on cut-through resistance. These include gage size of conductor, wall thickness and concentricity of insulation, multilayer insulation systems and conductor construction. A stranded conductor has the ability to flatten under load more easily than solid conductor thereby distributing the load more favorably. In addition, the number of strands and type of stranding can be a variable in cut-through resistance, therefore comparative testing on different insulation systems should be done on specimens whose conductor size and stranding are identical.

22.1.3 When this test method is used for specification purposes, the specific cutting edge and the test temperature must be stated in the specification.

22.2 Apparatus:

22.2.1 *Test Machine*—Use a universal tensile test machine as described in Test Method D 638 for this test. The machine shall be suitably equipped to operate in a compression mode. In addition, it shall be provided with a 12V a-c or d-c detection circuit which will sense the contact of the cutting edge with the metallic conductor and stop the cross-head travel. The testing machine shall be equipped with a recorder which will permit determination of the maximum force encountered during the test. When required, the machine shall be equipped with an environmental chamber capable of maintaining temperatures within  $\pm 2^{\circ}\text{C}$  ( $\pm 4^{\circ}\text{F}$ ).

22.2.2 *Cutting Edges*—The standard cutting edge shall be formed by a standard 0.508-mm (0.0200-in.) diameter sewing needle or steel music wire backed up by a 90° support with a half cylindrical groove machined to conform to the needle. A means such as clamps at each end must be provided to hold the needle securely against the support fixture. This cutting edge assembly is illustrated in Fig. 18 and shall conform to the dimensions as noted.

22.2.2.1 An optional cutting edge may be made from tungsten carbide, or equivalent, and shall conform to the dimensions shown in Fig. 19.

NOTE 17—For wall thicknesses greater than 0.38 mm (0.015 in.) use crush resistance test.

22.2.2.2 For convenience the edge may be permanently fastened to a metal shank by any suitable means, such as conductive epoxy adhesive.

NOTE 18—Experience has shown that dynamic cut-through tests performed by different laboratories on wire specimens taken from the production lot have yielded inconsistent results unless great care was taken to accurately duplicate the shape of the cutting edges. With flat edges, the width of the cutting edge can be measured with a properly

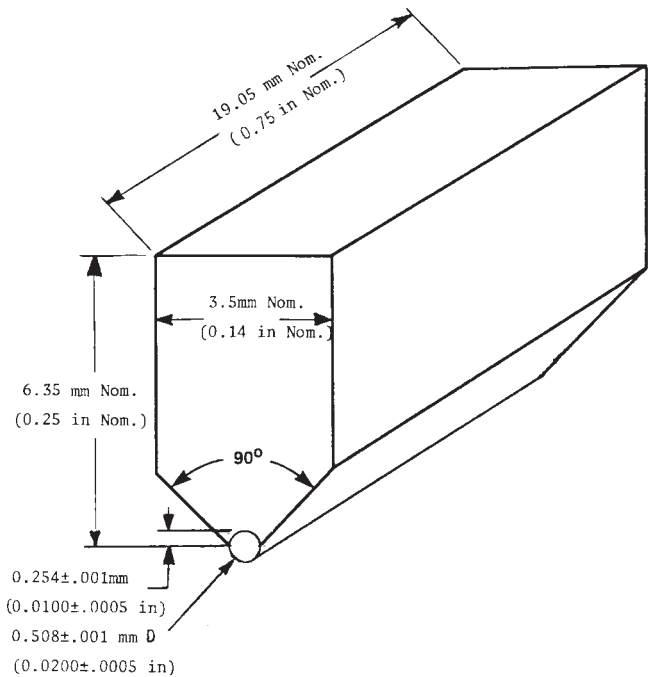

FIG. 18 Standard Cutting Edge

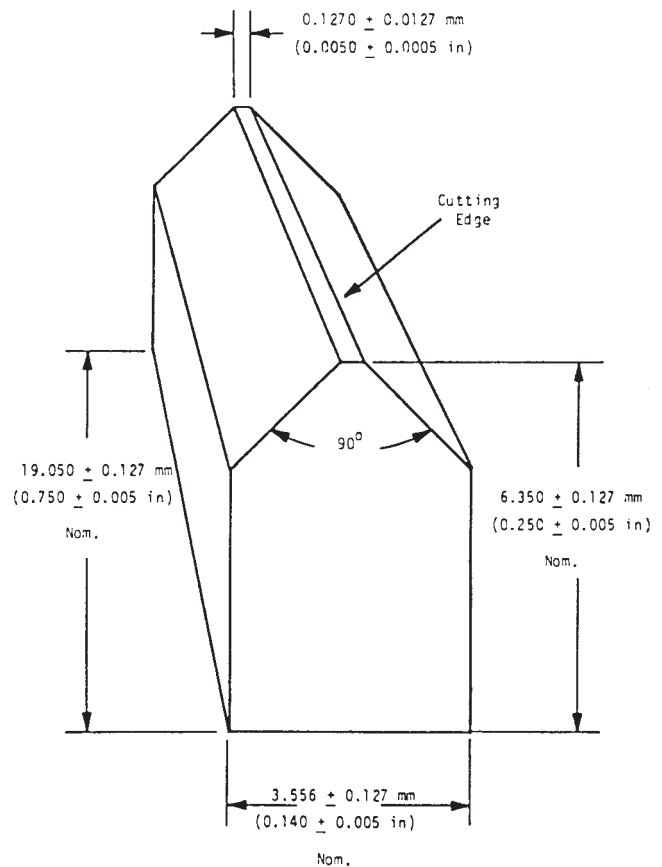

FIG. 19 Optional Cutting Edge

calibrated microscope and several measurements can be made along the length of the cutting edge to ensure uniformity. Shadow-graph techniques, however, are unacceptable because they yield information regarding the profile of the cutting tool at the end faces only.

22.2.3 *Support Anvil*—The specimen support shall be a flat metal surface which will hold the specimen in opposition to the cutting edge.

22.3 *Test Specimen*—The test specimen shall be a single 450 mm (18 in.) length of insulated wire. Remove sufficient insulation from one end of the specimen for connection to the detection circuit. Measure wall thickness and determine concentricity in accordance with Sections 15 and 16 of these test methods.

22.4 *Conditioning:*

22.4.1 Unless otherwise specified, the test specimens and the test apparatus, particularly the support anvil and the cutting fixture, shall be at a temperature of  $23 \pm 2^\circ\text{C}$  ( $73 \pm 4^\circ\text{F}$ ) at the time of test and shall have been maintained at that temperature for a minimum of 3 h prior to testing.

22.4.2 When performing tests at elevated temperature, the specimen and the test apparatus shall be stabilized at the desired temperature  $\pm 2^\circ\text{C}$  ( $\pm 4^\circ\text{F}$ ) prior to each individual test. This may require up to 1 h depending on chamber and specimen size.

22.5 *Procedure:*

22.5.1 Place the specimen on the support anvil and orient the cutting edge perpendicularly to the axis of the specimen. Connect the detection circuit. Force the cutting edge through the insulation at a constant rate of 5 mm (0.2 in.) per minute until contact with the conductor occurs.

22.5.2 Perform eight tests on each specimen, with the specimen being moved forward 25 mm (1 in.) minimum, and rotated  $90^\circ$  always in the same direction before subsequent tests. Record the maximum force indicated during each test. The cut-through resistance shall be the arithmetic mean of the eight test result values.

22.6 *Report:*

22.6.1 Report the following information:

22.6.2 Complete description of the wire construction tested, including dimensions and concentricity,

22.6.3 Temperature of test if other than  $23 \pm 2^\circ\text{C}$ ,

22.6.4 Description of cutting edge including shape and dimensions, and

22.6.5 Individual values and mean of the eight test results.

22.7 *Precision and Bias:*

22.7.1 A precision statement is under development.

22.7.2 A statement of bias is not possible due to the lack of a standard reference material.

## 23. Fluid Immersion

23.1 *Significance and Use:*

23.1.1 The resistance of hookup wire insulation to attack by various fluids is dependent upon the composition of the insulation material and may be influenced by the conditions encountered during wire manufacture. This test method serves to determine the affect of fluid immersion on hookup wire by measuring changes, if any, in the diameter of the wire and the physical integrity of the insulation after immersion in selected fluids for specified times and temperatures followed by mandrel wrap testing. Insulation materials which are softened by exposure to certain fluids may lack the physical strength to conform to the mandrel wrap test requirements. Insulation materials which contain extractible plasticizers may become

too stiff and brittle to survive the mandrel-wrap test requirements. Exposure to higher temperature increases the severity of the affects of immersion.

23.1.2 When this test method is cited in specification, the mandrel diameters, weights, fluids to be used, and the time and temperature of immersion must be specified.

23.2 *Apparatus:*

23.2.1 *Covered Glass or Metal Containers*— These containers must not be affected by the fluid at the stated test conditions. The containers shall be sized so that the volume of fluid will be at least 20 times the volume of the immersed specimens and the containers shall be sufficiently large to hold the specimens in their test geometry.

23.2.2 *Air Oven, Water Bath, Oil Bath*, or other heating equipment to maintain the test fluid at the specified temperature with  $\pm 2^\circ\text{C}$  ( $\pm 3.6^\circ\text{F}$ ).

23.2.3 *Rigid Metal Wrap Test Mandrels*, of various sizes as specified.

23.3 *Test Specimens*—Cut three specimens of hookup wire, each approximately 600 mm (24 in.) long, for each fluid for which an immersion test is to be performed. Specimens greater than 2.5 mm (0.1 in.) in outside diameter must be cut longer in order to obtain the immersion configuration described in 23.5.3. Use the following calculation to estimate the appropriate minimum cut length:

$$\text{Length} = 120 (\text{outside diameter}) + 300 \text{ mm (12 in.)} \quad (12)$$

23.4 *Conditioning*—Condition the test specimens for 24 h at  $23 \pm 3^\circ\text{C}$  ( $73.4 \pm 5.4^\circ\text{F}$ ) and at  $50 \pm 5\%$  relative humidity prior to the immersion test.

23.5 *Procedure:*

23.5.1 Screen all specimens for electrical flaws in accordance with 8.3.2 and replace any faulty specimens before proceeding.

23.5.2 Measure and record the outside diameter at three points along the specimen: (a) at approximately the center of the specimen length, and

(b) at points approximately 100 mm (4 in.) on each side of the center. These measurements shall be made in accordance with Section 15.

23.5.3 Prepare each specimen for immersion by forming a loop in its center consisting of one and one-half turns of wire. The loop diameter shall be a minimum of 20 times and a maximum of 30 times the specimen outside diameter. Secure each free end loosely at the point of tangency to the complete loop by a suitable means, such as lacing cord or tie-wraps made of a material which will not be adversely affected by the fluid involved. Join the two free ends together by twisting the conductors or by a suitable fastener, such as tape.

23.5.4 Immerse three specimens in each fluid specified by the applicable hookup wire specification to within 150 mm (6 in.) of the specimen ends making certain that the central loop is completely immersed. Maintain the test fluid for the time and the temperature specified in the applicable specification.

NOTE 19—See Appendix X4 for a list of commonly used fluids for immersion testing.

23.5.5 At the end of the immersion period remove the specimens from the fluid, remove the restraining ties, and allow

the specimens to stand in air for one hour at  $23 \pm 3^\circ\text{C}$  ( $73.4 \pm 5.4^\circ\text{F}$ ). Wipe off any excess fluid that may remain on the specimen after the 1 h stabilizing period. Remeasure and record the diameter of each specimen at the same locations as in 23.5.2.

23.5.6 If specimens are longer than 600 mm (24 in.), cut the central 600 mm section from the specimen by removing and discarding an equal length from each end; remove approximately 25 mm (1 in.) of the insulation from each end of each specimen.

23.5.7 Attach one end of the specimen to the wrap test mandrel of the specified diameter. Attach the specified weight to the opposite end. See Appendix X5 for suggested mandrels and weights when not described in the wire specification. Rotate the mandrel until the full specimen length is wrapped around the mandrel while under the tension provided by the weight. Each turn of the specimen shall be in contact with each adjacent turn. Reverse the rotation of the mandrel to unwrap and wrap in the reverse direction so that the insulation surface which was on the outside in the first wrap is now in contact with the mandrel. Repeat this process to obtain a total of two wraps and two reverse wraps on the same specimen. At the end of the wrapping operation and while still on the mandrel, visually examine the insulation surface for evidence of cracks or other deterioration.

23.5.8 Carefully remove the specimen from the mandrel and subject it to the voltage withstand test in accordance with Section 8 using the proof voltage specified in the wire specification.

23.6 Report:

23.6.1 Report the following for each fluid immersion performed:

23.6.1.1 Complete description of the wire construction tested, including dimensions and conductor gage,

23.6.1.2 Time and temperature of immersion and description of fluid used,

23.6.1.3 Change in diameter following immersion expressed as a percentage of the original. Individual and mean values shall be reported,

23.6.1.4 Results of visual examination following wrap test, and

23.6.1.5 Results of voltage withstand following wrap test and the proof voltage used.

23.7 Precision and Bias:

23.7.1 The precision and bias statement for the dimensions method contained in Section 15 is applicable to the diameter measurements before and after fluid immersion.

23.7.2 No statement is made about either the precision or the bias for the wrap test following fluid immersion since the result merely states whether there is conformance to the criteria for success specified in the procedure.

24. High Temperature Shock

24.1 Scope—This test method covers the evaluation of short term severe thermal stress on wire insulations and jackets with respect to their resistance to cracking. This method applies to electrical insulation applied on wire in various gages and wall thicknesses, and includes those of multiple layering as primary insulation and insulating jackets.

24.2 Significance and Use—Under certain conditions, such as conductor current overload, wire insulations can become abnormally hot for short periods of time while in a physically stressed state and then rapidly cool when the current is reduced. This test serves as a means to determine the suitability of an electrical insulation prior to being specified or put into service under such conditions.

24.3 Apparatus:

24.3.1 Oven Test Chamber, as described in Specification D 2436.

24.3.2 Mandrel, of sufficient length to accept six (6) wraps of wire. Appropriate mandrel sizes are given in Table 3.

24.4 Test Specimens—Prepare a specimen of wire of sufficient length to be tightly wound for six (6) complete turns around the mandrel. Remove enough insulation from each end for electrical connections to be used in subsequent voltage withstand test. Make successive turns, such that they are in contact with one another, with both ends of the specimen securely held in place. A high temperature glass reinforced tape is a convenient means of attachment.

24.5 Procedure:

24.5.1 Place the specimen in a preheated air circulating oven at the temperature specified and for the period of time required for the specimen to reach thermal equilibrium. Time mainly depends on the desired temperature and the mass of wire tested.

24.5.2 Remove the specimen from the oven and allow a minimum of 30 min for the specimen to return to room temperature ( $20$  to  $25^\circ\text{C}$  ( $68$  to  $77^\circ\text{F}$ )). At the conclusion of this thermal cycle, examine the specimen for cracks. Internal cracks in the specimen can be indicated by circumferential depressions in the outer surface. Slide the coiled specimen from the mandrel and apply a voltage withstand test as described in Section 8 for the period of time in the applicable specification.

24.6 Report:

24.6.1 Report the following information:

24.6.1.1 Number of specimens tested,

24.6.1.2 Description of the wire specimen, including number of insulating layers, types of materials, conductor gage and stranding, and wall thickness,

24.6.1.3 Length of specimen,

24.6.1.4 Mandrel size,

24.6.1.5 Oven temperature used,

24.6.1.6 Whether or not the specimen withstood the required voltage for the specified time, and

24.6.1.7 Time of failure in case failure occurs.

TABLE 3 Mandrel Sizes for High Temperature Shock Test of Single Conductor Insulated Wire

| Conductor Size AWG or MCM <sup>A</sup> (mm <sup>2</sup> ) | Number of Adjacent Turns | Mandrel Size (Diameter) Multiply Outside Diameter of Insulated Wire by: |
|---|--------------------------|---|
| 8 (8.37) and Under  | 6                        | 1   |
| 6 (13.3) to 2 (33.6)                                      | 6                        | 2   |
| 1 (42.4)  | 1                        | 2   |
| 0 (53.5) to 4/0 (107)                                     | 1/2 (180° U-Bend)        | 2   |
| 250 (127) and larger                                      | 1/2 (180° U-Bend)        | 5   |

<sup>A</sup>MCM = thousand circular mils.

24.7 *Precision and Bias*—No statement is made about either the precision or the bias of the high temperature shock test method since the result merely states whether there is conformance to the criteria for success specified in the procedure.

**25. Partial Discharge (Corona) Inception and Extinction Voltage**

25.1 *Significance and Use:*

25.1.1 A detailed statement of the significance of the partial discharge inception voltage (PDIV) and extinction voltage (PDEV) is given in Method D 1868.

25.1.2 For a discussion of voltage ratings of Hook-up Wire see Annex Annex A2.

25.2 *Apparatus:*

25.2.1 Use the apparatus described in Method D 1868 for these measurements. It is useful to locate the apparatus in an area that can be darkened to visually locate external partial discharges.

25.3 *Specimen Preparation:*

25.3.1 Select a specimen of appropriate length so that its capacitance is matched to the needs of the detecting equipment to permit observation of discharges of 5 pC or less. Use Method D 1868 for guidance to determine this length.

25.3.2 *Specimens Without Shields:*

25.3.2.1 A suitable specimen of an insulated wire can be prepared by wrapping 10 turns of the wire around a mandrel approximately 10 times the outside diameter of the wire and holding the wire to the mandrel with tape. Each end of the wire should be extended beyond the mandrel so that the ends of the conductor can be joined and connected to the high voltage lead of the test set.

25.3.2.2 An alternative specimen can be prepared by taping the wire to a flat metal plate and bending both ends of the wire away from the plate for connection together and to the high voltage lead of the test set.

25.3.2.3 Twisted pair constructions can be measured between the two conductors with the specimen suspended in the air away from the ground. The ends of the wires shall be separated so that discharges do not occur at the connections or at the ends.

25.3.3 *Specimens With Shields:*

25.3.3.1 Prepare the specimens as shown in Fig. 20. Similar

preparation should be made on triaxial and shielded, multi-conductor cables.

25.4 *Procedure:*

NOTE 20—**Warning:** Lethal voltages may be present during this test. It is essential that the test apparatus and all associated equipment that may be electrically connected to it be properly designed and installed for safe operation. Solidly ground all metal parts that any person might come into contact with during the test. Thoroughly instruct all operators in the proper way to conduct the test safely. When making tests at high voltage with electrodes, particularly in compressed gas or in oil, the energy released at breakdown may be sufficient to result in fire, explosion, or rupture of the test chamber. The design of the test equipment, test chambers, and test specimens shall be such as to minimize the possibility of such occurrences, and to eliminate the possibility of personal injury.

25.4.1 *Specimens Without Shields:*

25.4.1.1 Connect the conductor or conductors in the specimen to the voltage source and the mandrel or plate to the ground side of the test equipment. The connection to the voltage source shall be far enough away from any ground potential to prevent discharges at the connection.

25.4.2 *Specimens With Shields:*

25.4.2.1 Connect shielded cables to the voltage source so that the voltage is applied between the conductor and the shield. Triaxial cables are connected between the conductor and the first shield for one measurement and between shields for the second measurement. Two-conductor cables are connected between the two conductors for one measurement and between each conductor and the shield for additional measurements. In all cases, the voltage shall be connected to the conductors except when measurements are being made between shields.

25.4.2.2 Immerse the specimen ends in electrical insulating oil until all of the connections are at least 6.4 mm (0.25 in.) below the surface of the oil. Measurements should not be started with air bubbles still visible in the oil.

25.4.3 Perform the measurements with a voltage source operating between 48 and 62 Hz.

25.4.4 Apply the voltage at a maximum rate of 50 V/s to specimens having a specified PDEV of 3 kV or less and 100 V/s for specimens having a specified PDEV above 3 kV.

25.4.5 Raise the voltage until partial discharges above the 5 pC level are detected and record this voltage as PDIV. Lower the voltage at the same rate until the discharges have stopped and record this voltage as the PDEV.

25.4.6 When specified, measurements can be made at a different discharge level, in a vacuum chamber at a simulated altitude or at temperatures other than ambient.

25.5 *Report:*

25.5.1 Report the following information:

25.5.1.1 Detailed description of the specimen, including the dimensions,

25.5.1.2 Type of ground electrode used for non-shielded constructions,

25.5.1.3 PDIV and PDEV for each measurement, and

25.5.1.4 Conditions of test, if other than ambient.

25.6 *Precision and Bias:*

25.6.1 The precision and bias of this method are in accordance with Method D 1868.

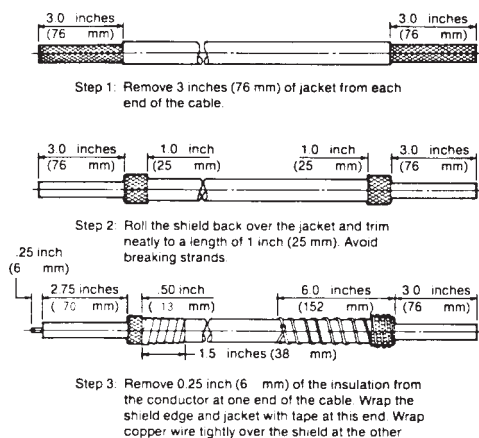

FIG. 20 Method of Preparing Cable for Partial Discharge

## 26. Cold Bend Test

### 26.1 Scope:

26.1.1 This test method provides a procedure for determining the low-temperature mechanical properties for flexible electrical insulating materials, and insulating systems used as primary insulation, primary jacket, and cable jackets on hookup wire.

26.1.2 Users of this test method must specify the mandrel diameter, test weight, and test temperature at which the test is to be conducted.

26.2 *Significance and Use*—The Cold Bend test is useful in comparing the capability of different types of wire and cable to be bent at low temperature, and as a quality control test to ensure that every production lot of wire exhibits a prescribed degree of low-temperature flexibility.

### 26.3 Apparatus:

26.3.1 The apparatus for this test method consists of a cold chamber, series of metal mandrels of the required overall diameters, and weights of sufficient magnitude to hold the wire or cable straight during exposure to the test temperature and during the winding operation. The cold chamber must be capable of maintaining the specified temperature with a tolerance of  $\pm 2^{\circ}\text{C}$  ( $\pm 4^{\circ}\text{F}$ ).

26.3.2 The cold chamber shall be arranged so that the specimens, mandrels and weights are in the cold chamber during the conditioning period and the tests can be performed without removing the specimens from the low temperature and without opening the door of the cold chamber.

26.3.3 Apparatus meeting the requirements of Test Method D 149 shall be used to perform the voltage-withstand test described in 26.5.

26.4 *Test Specimens*—The test specimens must be of sufficient length to allow the bending described in the test procedure plus an 80 mm (3 in.) or longer straight section at each end of the wound length. The specimen to be tested must consist of a complete wire or cable including outer coverings or jackets, if used. Unless otherwise specified, three specimens will be tested.

### 26.5 Procedure:

26.5.1 Hang the specimen from the mandrel after wrapping it around the mandrel for one full turn and securing it to the mandrel with a non-damaging mechanical device. Attach the specified weight to the lower end of the specimen. The weight should be sufficient to maintain the specimen in close contact with the mandrel during the winding operation.

26.5.2 Condition the specimens of finished wire or cable for a minimum of 4 h at the specified temperature.

26.5.3 Wind the specimen onto the mandrel at a uniform rate, not exceeding 4s/turn for the number of turns shown in Table 4, so that each turn is in contact with the mandrel and the adjacent turns of the specimen under test.

26.5.4 Remove the mandrel and the coiled specimen from the chamber and allow them to come to room temperature. Remove the coiled specimen from the mandrel without straightening. Strip the insulation from each end of each conductor for approximately 1 in. Connect the ends of each conductor together and immerse the coiled section of the specimen in a water bath containing 1% sodium chloride by

**TABLE 4 No. of Turns Around the Mandrel for Various Size Specifications Required for the Cold Bend Test**

| Conductor Size AWG (mm <sup>2</sup> )  | No. of Turns |
|--|--------------|
| 8 (8.4) and smaller                    | 6            |
| 6, 4 (13.3, 21.2)                      | 5            |
| 2 (33.6)                               | 4            |
| 1, 1/0 (43.2, 53.5)                    | 3            |
| 2/0, 3/0 (67.4, 85.0)                  | 2            |
| 4/0 (107) and larger                   | 1/2 (U-Bend) |
| <i>Cable Diameter:</i>                 |              |
| 0.250 inches (6.4 mm) and smaller      | 4            |
| 0.250 to 0.500 inches (6.4 to 12.7 mm) | 2            |
| Larger than 0.500 inches (12.7 mm)     | 1/2 (U-Bend) |

weight for a period of 1 h. The ends of the specimen should be above the liquid surface by at least 1 in. This procedure applies to primary insulation and shielded and unshielded cables.

26.5.5 Apply a 60 Hz, 1.5-kV rms withstand voltage, at a rate of rise of 0.5 kV/s between each of the insulated conductors and the water bath. Hold the 1.5-kV test voltage for 1 min. Failure is defined as drawing a current in excess of 10 mA/specimen as metered in the high-voltage circuit. For shielded constructions, the test voltage shall be applied between the shield and the water bath for one test and between each conductor and all other conductors tied to the shield for the remainder of the tests. For unshielded cables, apply the voltage between each conductor and all other conductors connected to the water bath.

### 26.6 Report:

26.6.1 Report the following information:

26.6.1.1 A complete description of the specimen including conductor size, insulation type and thickness, tapes and shields, and jacket type and thickness,

26.6.1.2 Temperature at which the test was performed and the duration of exposure,

26.6.1.3 Mandrel diameter and weight used for the winding operation,

26.6.1.4 The results of the visual examination, and

26.6.1.5 The results of the voltage withstand test.

26.7 *Precision and Bias*—No statement is made about either the precision or the bias of this test method for measuring low-temperature flexibility since the result merely states whether there is conformance to the pass/fail criteria specified in the procedure.

## 27. Strip Force Test

### 27.1 Scope:

27.1.1 This test method provides a standard procedure for determining the adhesion bond between the wire conductor and insulation to help predict the processability of an insulated wire on automatic and manual cut and strip machines.

27.1.2 The values derived from this test method must be specified by the user. The values will depend on the type of insulation, test equipment, the insulation material, size, and strip length of the test specimen.

27.2 *Significance and Use*—The Strip Force is useful in quality control procedures to ensure that every production lot of wire can comply with a prescribed minimum and maximum amount of force for insulation removal.

27.3 *Apparatus*—Use a tension testing apparatus as described in Test Method D 638 suitably equipped to operate in a tensile mode in conjunction with a fixture attached to one jaw of the tensile testing machine. The fixture is a metal plate approximately 0.2 in. (5 mm) thick with a hole 5 to 10 % larger than the conductor diameter of the test specimen and positioned normal to the applied force on the test specimen by the tensile testing machine to provide sufficient clearance of the conductor but retain the insulation without binding. The rate of travel of the testing mechanism shall be 2 in./min (50 mm/min)

27.4 *Test Specimens*—The test specimens shall be approximately 12 in. (300 mm) long. Select specimens from wire lots that have had a minimum of handling to prevent misleading test results. Unless otherwise specified, test a minimum of three specimens.

27.5 *Procedure:*

27.5.1 Allow the specimen to completely stabilize at room temperature.

27.5.2 Prepare the specimen for testing by carefully removing the insulation from both ends with the exception of a 1.0 in. (25.4 mm) section of undisturbed insulation located at a distance of 2.0 in. (50 mm) minimum from one end of the test specimen. Remove the insulation so that the exposed insulation ends are square with respect to the conductor.

27.5.3 Insert the long end of exposed conductor through the fixture hole and clamp this end to the traveling section of the tensile tester. Do without applying any force to the insulation test specimen and leave approximately 0.5 in. (13 mm) of slack between the fixture hole contact point and the insulation piece.

27.5.4 Using the tensile tester, pull the conductor approximately 1.0 in. (25 mm) through the insulation at a rate of 2.0 in./min (50 mm/min) and record the maximum force indicated. Do not displace the insulation over the end of the conductor.

27.5.5 Wrapped wire insulations are susceptible to a difference in strip force dependent on which end of the sample is presented for test. For these types, perform the test in both directions with the report indicating the test results for each.

27.6 *Report:*

27.6.1 Report the following information:

27.6.1.1 A complete description of the sample including conductor size and stranding, insulation type and thickness, and any specification number applicable to the sample,

27.6.1.2 The actual measured diameter of the conductor and the size of the hole in the fixture, and

27.6.1.3 The results of the test in pounds-force (Newtons) for the maximum values received for each specimen and the mean value.

27.7 *Precision and Bias:*<sup>17</sup>

27.7.1 Table 5 is based on an interlaboratory study conducted in 1988 using Practice E 691 as a guide. This study was conducted with 20 samples, and tests were performed in five laboratories. One type of insulation system was used with variations in wall thickness, gage size of conductors, conductor stranding and extrusion techniques. The samples were all manufactured at one factory, but all specimens were prepared

**TABLE 5 Strip Force—Precision Statistics (Values in the units of lbs.—force)**

| Sample | $\bar{X}^A$ | $s_x^B$ | $S_r^C$ | $S_R^D$ | $r^E$ | $R^F$ |
|--------|-------------|---------|---------|---------|-------|-------|
| 1      | 3.9000      | 2.6963  | 0.9791  | 2.8123  | 2.74  | 7.87  |
| 2      | 7.4200      | 1.3215  | 1.5233  | 2.2304  | 4.27  | 6.25  |
| 3      | 5.0000      | 2.4213  | 0.4984  | 2.4553  | 1.40  | 6.87  |
| 4      | 6.7067      | 2.2315  | 0.6789  | 2.2993  | 1.90  | 6.44  |
| 5      | 4.5661      | 1.4168  | 0.3718  | 1.4489  | 1.04  | 4.06  |
| 6      | 3.7267      | 0.9041  | 0.5952  | 1.0265  | 1.67  | 2.87  |
| 7      | 4.6000      | 1.2245  | 0.7749  | 1.3783  | 2.17  | 3.86  |
| 8      | 5.4400      | 1.6363  | 1.1761  | 1.8973  | 3.29  | 5.31  |
| 9      | 2.4733      | 0.4271  | 0.1726  | 0.4498  | 0.48  | 1.26  |
| 10     | 5.1800      | 1.4290  | 0.5073  | 1.4878  | 1.42  | 4.17  |
| 11     | 2.0400      | 0.6287  | 0.1193  | 0.6362  | 0.33  | 1.78  |
| 12     | 3.6333      | 1.9057  | 0.6096  | 1.9696  | 1.71  | 5.51  |
| 13     | 5.1333      | 2.2661  | 0.3380  | 2.2828  | 0.95  | 6.39  |
| 14     | 4.6467      | 0.5796  | 0.3658  | 0.6520  | 1.02  | 1.83  |
| 15     | 1.3170      | 0.5251  | 0.2773  | 1.4489  | 0.78  | 4.06  |
| 16     | 2.1733      | 0.8190  | 0.2072  | 0.8363  | 0.58  | 2.34  |
| 17     | 2.9333      | 0.6223  | 0.3972  | 0.7017  | 1.11  | 1.96  |
| 18     | 2.9400      | 0.6030  | 0.2022  | 0.6252  | 0.57  | 1.75  |
| 19     | 3.2533      | 0.7128  | 0.5112  | 0.8260  | 1.43  | 2.31  |
| 20     | 1.9267      | 0.8792  | 0.2181  | 0.8971  | 0.61  | 2.51  |

<sup>A</sup>  $\bar{X}$  is the average for the sample.

<sup>B</sup>  $s_x$  is the standard deviation on the average.

<sup>C</sup>  $S_r$  is the within-laboratory standard deviation of the average.

<sup>D</sup>  $S_R$  is the between-laboratories standard deviation of the average.

<sup>E</sup>  $r$  is the within-laboratory repeatability limit = 2.8  $S_r$ .

<sup>F</sup>  $R$  is the between-laboratory reproducibility limit = 2.8  $S_R$ .

in the laboratories doing the tests. Sixty determinations were made in each laboratory with three determinations made on each sample.

27.7.2 Do not apply the precision statistics from Table 5 rigorously to the acceptance or rejection of material. These data are specific to this interlaboratory study and may not be representative of material or construction variations of all hookup wire. Users of this test method should apply Practice E 691 to develop data specific to their laboratory, material or construction.

27.7.3 This test method has no bias because the strip-force value is defined in terms of this method.

**28. Wet Arc-Tracking**

28.1 *Scope:*

28.1.1 The Wet Arc-Tracking Test for wire insulation provides a comparative assessment of degradation from tracking in the presence of wet, ionizable contaminants on the insulation surface. This test method is for use in obtaining comparative data and the degree of correlation with actual end use experience has not been established.

28.2 *Significance and Use:*

28.2.1 The 7-wire bundle test specimen represents in a simple fashion the way in which wire may be used in service. The test specimen geometry and the test procedure design give reproducible results in a reasonable time of test. Actual service involves many other considerations (see Appendix X6).

28.2.2 The test conditions are representative of those that may be encountered in service. (A practical test cannot include the wide variety of conditions involved in actual service.) (See Appendix X6.)

28.2.3 In service, insulated wire can be exposed to moisture for periods, which may be short (often just minutes), at repeated, widely-spaced intervals of time. In consequence, the

<sup>17</sup> A research report containing all of the information generated in this round-robin is available from ASTM Headquarters. Request RR:D09-1032.

damaging scintillation during such exposure also occurs repeatedly over just short periods. Thus tracking may progress quite slowly so that considerable time, even months or years, may elapse before the final failure occurs. In this test, continuous scintillation is maintained so that the rate of tracking is accelerated. Thus, the results of the test are obtained in a short time.

28.2.4 The degradation observed in this test from a single arc, arcing which progresses from wire to wire in the bundle or open circuits (from conductor corrosion) is characteristic of failures which may occur in service. The additional action, which may take place when power is reapplied in those cases where the breakers open in the initial test, is especially important.

28.2.5 The time to termination of the test is not important. Arc propagation away from the initiating damage to the test bundle is of the most concern. Of especial concern is reestablishment of arc propagation when the system is reenergized.

28.3 Apparatus:

28.3.1 *Schematic*—a sketch of the apparatus is given in Fig. 19, and consists of the following:

28.3.2 *Protective Screen and Test Location*—a transparent screen to protect laboratory personnel from molten metal, UV radiation and other debris that may be ejected from the test specimen. Conduct the test in a ventilated, but relatively draft-free location, to remove any potentially toxic fumes, if present.

28.3.3 *Power Supply*—three phase, Y connected, 120/208 V, 50 or 60 Hz commercial line power or a 400 Hz rotary converter of 5 kVA or larger capacity. Use a one-ohm, 200 watt, wire wound resistor in series with each phase between the supply and test equipment. (Details are given in Annex A1.)

28.3.4 *Dropping Apparatus*—A variable speed, peristaltic pump or suitable other apparatus to deliver the electrolyte solution at a rate of  $100 \pm 10$  mg/min to the test specimen through a squarely cut off 18 gage hypodermic needle. (Note 19.) An alternative means of delivery is acceptable, if the rate and drop size are the same as for the needle.

NOTE 21—For example, an 18 gage hypodermic needle (US) will give approximately 12 drops/min with the electrolyte solution suggested in 28.4.

28.3.5 *Timer*—A timer capable of resolving time from 0.0017 to 100 h (6 s to 100 h).<sup>18</sup>

28.3.6 *Mechanical Supports*—A means of supporting the specimen in free air at approximately 10° from the horizontal. The support also holds the hypodermic needle (or acceptable alternative) of the dropping apparatus 10 ± 2 mm above the specimen. Position a dish or basin to catch any excess electrolyte that drips from the specimen during the test.

28.4 *Electrolyte*—Unless otherwise specified, dissolve 2 ± 0.01 g of reagent grade ammonium chloride (NH<sub>4</sub>Cl) and 100 ± 0.1 mg of Isooctylphenolpolyethoxyethanal, the polethoxy

chain to contain approximately 10 ethoxy units,<sup>19</sup> a non-ionic wetting agent in enough distilled water to make 100 ± 1 g of electrolyte solution. When specified, other electrolytes may be used. Equivalent test results may not be obtained. Fig. 21

28.5 *Test Specimen*—The test specimen consists of an assembly of seven 200 to 400 mm long AWG 20 hookup wires cut from a continuous piece. Two wires have circumferential cuts made approximately midway in their length exposing 0.5 to 1.0 mm of the conductor (see Fig. 22).

28.5.1 Remove a short length of insulation from each end of the seven wires to allow connection to the power supply and to open circuit detection equipment.

28.5.2 Clean each wire with a clean cloth moistened with isopropyl alcohol to remove surface contamination. Handle the wires as little as possible after cleaning.

28.5.3 Assemble the seven lengths of hookup wire in a six-around-one configuration without twisting. Position the wires with the exposed conductors adjacent, on the outside, and with the exposed conductors separated longitudinally by  $10 \pm 0.5$  mm (see Fig. 22).

28.5.4 Secure the seven wires tightly together in the test area with two ties, as shown in Fig. 22. Position the two ties 3 to 5 mm above and below the exposed conductors. Use fluorocarbon-coated glass lacing cord or equivalent non-combustible and non-melting material (Mil-T-43435B, Type IV, Size 3, Finish D is suitable). Hold the balance of the specimen together with lacing cord or cable ties at 15 to 20 mm intervals. Insure that the individual wires are parallel and in contact with each other in the test area between the exposed conductors.

28.6 Procedure:

28.6.1 Using the mechanical supports, mount the specimen in a draft-free location so that the wires with the exposed conductors are uppermost. Condition the test specimens for at least 48 h and conduct the test at Standard Laboratory Temperature (see Methods D 618).

28.6.2 Connect the leads from the shutdown circuitry to the upper end of the specimen as shown in Fig. 23. Connect

<sup>19</sup> Isooctylphenolpolyethoxyethanal with the polethoxy chain containing approximately 10 ethoxy units is available as Triton X-100 from the Rohm and Haas Company, Philadelphia, PA.

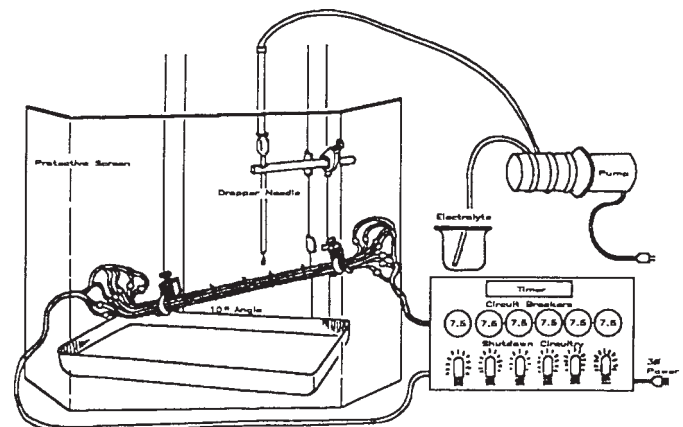

FIG. 21 Wet Arcing and Tracking Apparatus

<sup>18</sup> Kessler-Ellis Products, Atlantic Highlands, NJ, Model MTHM.16.21 or A. W. Haydon, Waterbury, CT, Model D12550-P3 is suitable.

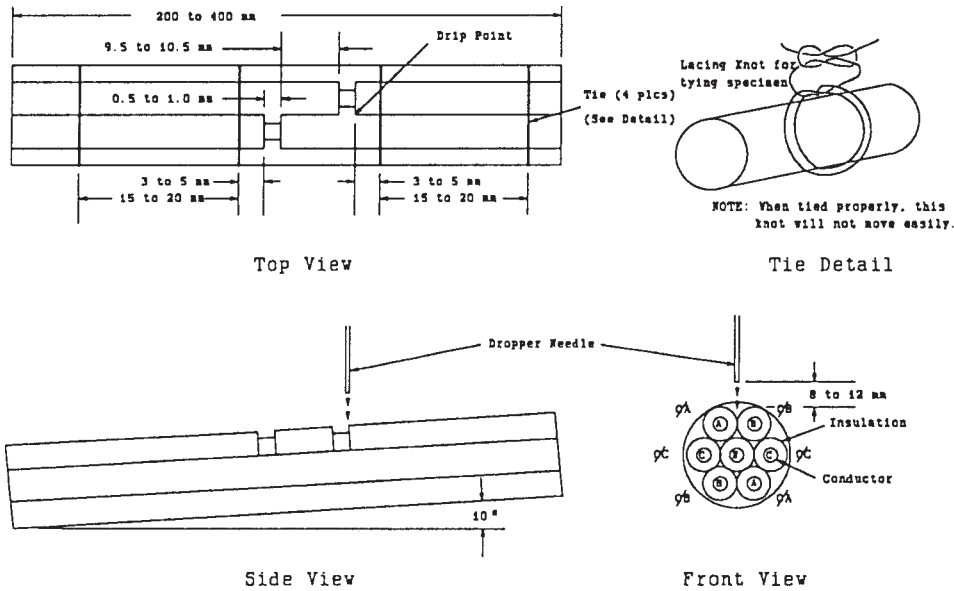

FIG. 22 Assembly of the Wire Bundle

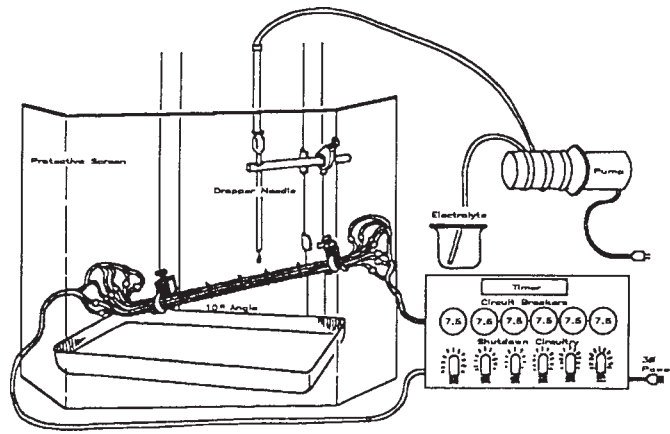

FIG. 23 Shutdown Equipment Schematic

adjacent wires in the specimen to alternate phases. Connect the central wire of the specimen to the neutral of the power supply.

28.6.3 Connect the leads from the open circuit detection circuitry to the lower end of the specimen. Bend these wires upward enough to act as a drip-loop for any excess electrolyte.

28.6.4 Adjust the flow of the electrolyte to provide  $100 \pm 10$  mg/min flow rate. (If later in the test it appears that activity is being “drowned” by too much electrolyte, decrease the flow as needed to insure that the activity continues.)

28.6.5 Position the hypodermic needle to drop the electrolyte into the groove between the wires at the uppermost exposed conductor. Position the tip of the hypodermic needle so that the vertical distance is  $10 \pm 2$  mm above the specimen (see Fig. 22).

NOTE 22—**Caution:** Position the protective screen to shield the operator from any ejected molten metal and UV radiation.

28.6.6 Activate the “start” switch, to apply power and start the timer. This action electrically energizes the specimen and simultaneously starts the flow of electrolyte.

28.6.7 Activity will start in a few minutes with steaming and subsequently scintillation that is observable in a darkened room

or with an oscilloscope. If scintillation is not observed after 10 min, turn the power off and forcibly wet the area between the exposed conductors with the end of a short length of the sample wire dipped in the electrolyte. Reset the clock and restart the test.

28.6.8 Run the test until an automatic shutdown occurs. If automatic shutdown does not occur within a normal workday, the test may be interrupted and restarted the next day.

28.6.9 In more than three, but less than 10 min after an automatic shutdown, close any opened circuit breakers. Reapply power with the automatic shutdown circuitry deactivated and no further flow of electrolyte. Leave the power on long enough so that any arc propagation develops fully. Do not reset any circuit breakers again.

28.6.10 Complete five tests by repeating steps 28.6.1-28.6.10.

28.6.11 Following each test series, check all circuit breakers for correct operation at 200 % rated current (see A1.4).

28.7 Report:

28.7.1 Report the following for each test:

28.7.1.1 A description of the wire tested—The size and type of conductor, the nature and thickness of the insulation, the description under an applicable MIL, UL or other specification, and optionally the trade name,

28.7.1.2 The power, voltage and frequency rating of the three phase power supply,

28.7.1.3 The series resistance in each phase,

28.7.1.4 The composition of the electrolyte,

28.7.1.5 The flow rate of the electrolyte,

28.7.1.6 Was forced wetting necessary,

28.7.1.7 The time in minutes to the first shutdown,

28.7.1.8 The number of open (circuit) breakers,

28.7.1.9 The number of open-circuited wires,

28.7.1.10 The number of short-circuited wires and the resistance between those not short-circuited,

28.7.1.11 Additional arc propagation on reclosing the open circuit breakers and repowering (see section 28.5.10 ),

28.7.1.12 The number of circuit breakers which open again after reclosing and repowering (see 28.6.10),

28.7.1.13 Any other observation or comment deemed important, and

28.7.1.14 A summary of the test results in suitable form (see Fig. 24 for a suggested test report form).

28.8 Precision and Bias—The precision and bias of this method are under consideration and are awaiting evaluation.

**29. Dry-Arc Tracking**

*29.1 Scope:*

29.1.1 The Dry-Arc Tracking Test for wire insulation provides a comparative assessment of insulation degradation and arc propagation between wires in a bundle when arcing is caused by damage from a reciprocating aluminum blade (arcing edge).

*29.2 Significance and Use:*

29.2.1 The 7-wire bundle test specimen represents, in a simple fashion, the way in which wire may be used in service. The arcing between two predamaged wires of the test bundle,

caused by the action of a grounded reciprocating aluminum blade in contact with them, is intended to represent the degradation from arcing and from possible arc propagation resulting from damage by abrasion or chafing in service.

29.2.2 The assessment of arc propagation, and damage to wires in the bundle which are not involved in the initial arc, are important. Additional action is especially important. Additional action, which may occur when power is reapplied to the specimen, in those cases where the breakers open in the initial test, is especially important.

29.2.3 This test uses a three phase, 120/208 V, 400 Hz source of power, or as is appropriate to the application. Other commonly used voltages or frequencies, such as 28 V d-c may give different results. However, no evidence exists to suggest that any degradation at 28 V dc would escape detection at 120 V, 400 Hz.

29.2.4 This test method is for use in obtaining comparative data. The degree of correlation with actual end use experience is not established.

*29.3 Apparatus:*

29.3.1 Schematic—A sketch of the apparatus is given in Fig. 23.

29.3.2 Protective Screen and Test Location—Use a transparent screen to protect laboratory personnel from UV radiation, molten metal and other debris that may be ejected from the test specimen. Conduct the test in a ventilated, but relatively draft free, location to remove any potentially toxic fumes.

29.3.3 Power Supply—Use a three phase, Y connected, 120/208 V, 400 Hz rotary converter of 5 kVA or larger capacity, as appropriate. An alternate power supply appropriate to the application is allowed (see 3.2.3). Use a one-ohm, 200 watt, wire wound resistor in series with each phase between the supply and the test equipment. (Details are given in Annex A1.) In addition, provide a means to manually override the automatic shut down circuit. Fig. 23 of Section 28 shows a diagram of suitable shutdown equipment.

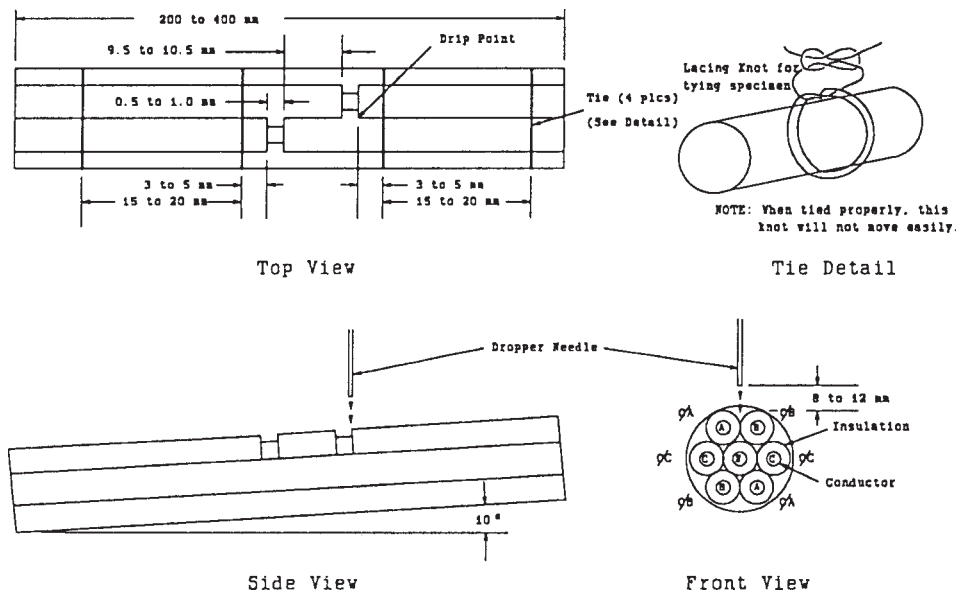

FIG. 24 Summary of Test Results

29.3.4 *Reciprocating Apparatus*—Use a test fixture which holds the aluminum blade at a 90° angle to the test specimen (Fig. 25). Clamp the test specimen with approximate 50 mm spacing so as to hold the individual wires in close proximity. The reciprocating mechanism provides an oscillating motion with a 5 to 15 mm stroke at a frequency of 10 to 30 Hz such that the product of the frequency (Hz) and stroke (mm) is between 150 and 450.

29.3.4.1 Make the aluminum blade (Fig. 26) using the fixture shown in Fig. 27.

29.3.4.2 Adjust the downward force for the aluminum blade to 0.5 to 0.6 N (50 to 60 g weight).

29.3.4.3 Position a mechanical stop mechanism as far from the vibration driver as possible to limit the fall of the oscillating aluminum blade. Preferably locate the specimen bundle between the driver and the stop.

29.3.4.4 Provide a means to separate the aluminum blade from the test specimen in 3 to 10 s after the specimen open circuits or electrical shut down occurs.

29.3.4.5 Provide an electrical connection from the aluminum blade to the neutral of the power supply.

29.4 *Test Specimen:*

29.4.1 Cut a wire sample of length sufficient to meet the requirements of Section 8.

29.4.2 Test this sample according to Section 8 at the specified proof voltage for the wire. If a proof voltage is not specified, use 1000 V ac.

29.4.3 Construct the test specimen as described in 28.5 and 28.5.1 to 28.5.4, Wet Arc-Tracking Test, except that the exposed portion of the conductors are positioned adjacent to each other instead of separated as described in 28.5.3.

29.5 *Procedure:*

29.5.1 Connect the seven wires of the test bundle as shown in Fig. 23 (Wet Arc-Tracking Test) to the power supply described in 29.3.3.

29.5.2 Place the specimen in the test fixture so the predamaged wires are uppermost. Locate the specimen so that in the lowered position the aluminum blade contacts both exposed conductors.

29.5.3 Limit the blade's fall to an additional half-wire diameter from its point of contact with the conductors (see Fig. 25). Adjust the stop's initial gap to a distance equal to half of

Direction of sander motion to minimize 'feather edge' on active portion of Aluminum Blade.

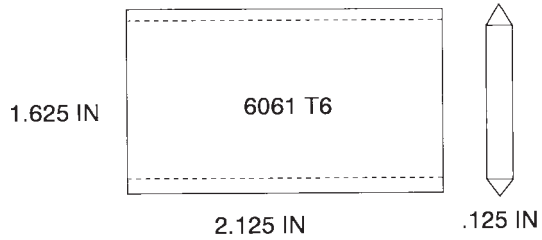

Grind on 60 Grit Alumina Disc Sander  
FIG. 26 Aluminum Blade

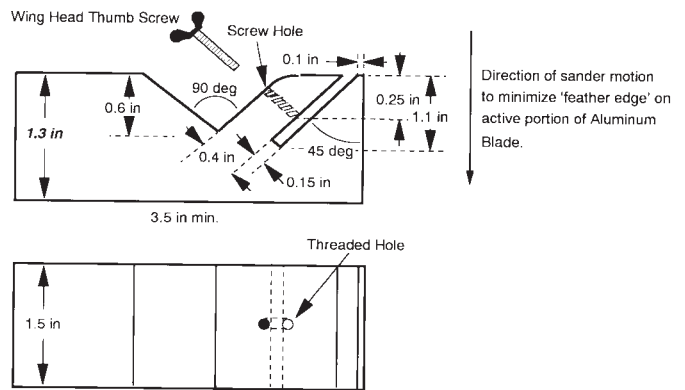

FIG. 27 Aluminum Blade Shaping Fixture

the wire's OD multiplied by the ratio of the 'stop to pivot' distance and the 'specimen to pivot' distance.

29.5.4 Adjust the frequency and stroke of the reciprocating apparatus in accordance with 29.3.4, unless otherwise indicated in an individual wire specification.

29.5.5 Position the transparent screen to protect laboratory personnel from UV radiation, molten metal and other debris that may be ejected from the test specimen.

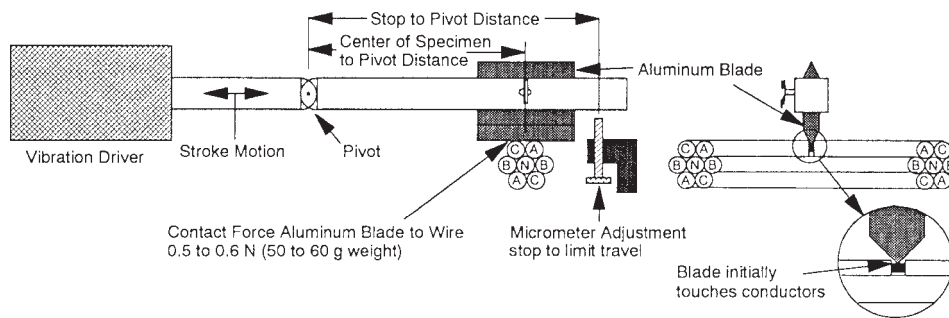

FIG. 25 Apparatus

29.5.6 Start the reciprocating drive. Ensure that the aluminum blade oscillates across the exposed conductors (the cuts in the wire). Apply electrical power 1 s after starting the reciprocating action.

29.5.7 Using suitable eye protection or a video monitor system, observe the degree and nature of any action, such as arcing or arc propagation, before and when electrical shutdown occurs.

29.5.8 Remove the aluminum blade from the test bundle within 3 to 10 s of electrical shutdown. Deactivate the automatic shut down circuit. Reset the thermal circuit breakers after removing power and then reapply power just once. Using the same precautions of 29.5.7, observe and record any continuing arcing and arc propagation, if present.

29.5.9 At the end of each test, separate the wires of the bundle. Examine each wire for visible damage. Suggested criteria are shown in Fig. 28. Conduct a voltage withstand test in accordance with Section 8, at the specified proof voltage for the wire, on each apparently undamaged wire. If a voltage is not specified, use 1000 V ac.

29.5.10 Test a total of nine specimens. Use a new wire bundle and aluminum blade for each test.

29.5.11 Prior to each test series check all circuit breakers for correct operation at 200 % rated current (see A1.4 to Section 28—Wet Arc-Tracking Test).

29.6 Report:

29.6.1 Report the following for each test:

29.6.1.1 A description of the wire tested—The size and type of conductor, the nature and thickness of the insulation, the description under an applicable MIL, UL or other specification, and optionally the trade name,

29.6.1.2 The power, voltage and frequency ratings of the three phase power supply,

29.6.1.3 The series resistance in each phase,

29.6.1.4 The applied force, stroke and frequency of the reciprocating apparatus,

29.6.1.5 Details of activity observed during the initial test, such as the degree of arcing, arc propagation and operation of circuit breakers,

29.6.1.6 The time, s, to shut down (circuit breakers opening), after application of power,

29.6.1.7 The number of open circuit breakers,

29.6.1.8 Additional activity, such as arcing and arc propagation, that results when breakers opened during initial testing are closed and the test setup is repowered,

29.6.1.9 Type of visual damage to the insulation of each wire removed from the bundle including the length of insulation damage (see Fig. 28 for suggested criteria),

29.6.1.10 Results of the voltage withstand test for each of the originally uncut wires removed from the test bundle,

29.6.1.11 Any other observation or comment deemed important, and

29.6.1.12 A summary of test results in suitable form (see Fig. 29).

29.7 Precision and Bias:

29.7.1 The precision of this test method is under consideration and awaits evaluation.

29.7.2 A statement of bias is not possible due to a lack of a standard reference material.

30. Keywords

30.1 ambient temperature; arcing; arc-propagation; arc-tracking; atmospheric pressure; breakdown voltage; cable; circuit breakers; current limiting; cuts; degradation; dropping apparatus; dry-arcing; electrical insulation; electrolyte; extinction voltage; flame propagation; flame spread; flame test; flammability; hookup wire; insulation thickness; moisture; open-circuit detection; partial discharge; power supply; safe voltage; scintillation; service condition; short-circuit detection; shutdown equipment; track resistant; tracking; transportation vehicles; voltage rating; wet; wire abrasion; wire chafing; wire insulation

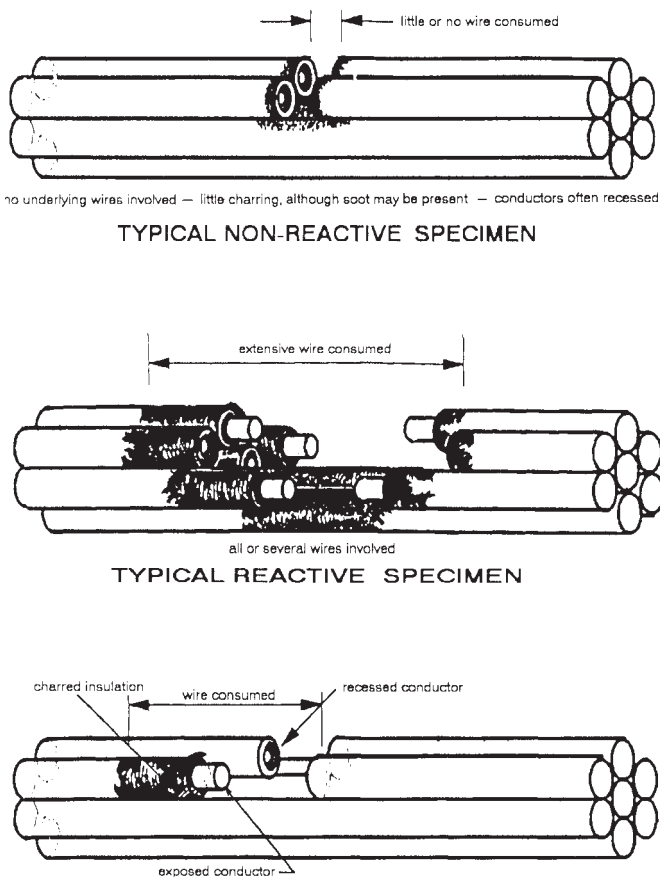

FIG. 28 Specimen Measurements

Laboratory \_\_\_\_\_ Date \_\_\_\_\_

|  |   |   |   |   |   |   |   |   |   |
|--|---|---|---|---|---|---|---|---|---|
| Wire Description:  |   |   |   |   |   |   |   |   |   |
| Applied Force _____ Stroke _____ Frequency _____                   |   |   |   |   |   |   |   |   |   |
| Series Resistance _____ Power Supply _____ kVA, Frequency _____ Hz |   |   |   |   |   |   |   |   |   |
| Test Number  | 1 | 2 | 3 | 4 | 5 | 6 | 7 | 8 | 9 |
| Mode of Initial Termination <sup>1</sup>                           |   |   |   |   |   |   |   |   |   |
| CB <sup>2</sup> Tripped  |   |   |   |   |   |   |   |   |   |
| Conductors Interrupted   |   |   |   |   |   |   |   |   |   |
| Length of Damage (max)   |   |   |   |   |   |   |   |   |   |
| CB's Reset   |   |   |   |   |   |   |   |   |   |
| CB's retripped   |   |   |   |   |   |   |   |   |   |
| Additional Action  |   |   |   |   |   |   |   |   |   |
| Conductors interrupted   |   |   |   |   |   |   |   |   |   |
| Length of Damage (max)   |   |   |   |   |   |   |   |   |   |
| Final # of Wires Damaged <sup>2</sup>                              |   |   |   |   |   |   |   |   |   |
| Additional Comments:   |   |   |   |   |   |   |   |   |   |

Total No. of damaged wires: \_\_\_\_\_ of \_\_\_\_\_

<sup>1</sup>M=Mild Arcing, A=Massive Arcing, N=No Action, SP=Short Spilt, L=Large Arcing, SC=Short Circuit  
<sup>2</sup>Based on the specified proof voltage, or 1000 Volts ac, if not specified, excluding originally cut wires

**FIG. 29 Example of a Data Sheet**

## ANNEXES

### (Mandatory Information)

#### A1. POWER SUPPLY

A1.1 *Power Source*—Use a 3-phase, Y connected, 120/208 volt, 50 or 60 Hz commercial line power or a 400 Hz rotary converter of 5 kVA or larger capacity as the power supply. A standard 20 A branch distribution circuit provides this capability when fed from a normal panelboard. Suitable commercial rotary converters are available to supply 400 Hz.<sup>20</sup> Supply the test setup through a 200 watt, one-ohm resistor in each phase.<sup>21</sup>

A1.2 *Disconnecting Means*—Provide a means to isolate the test set-up from the power supply. (A commercial 3 phase, NEMA Size 2 magnetic motor starter relay with a 120-volt a-c coil is a suitable device.)

A1.3 *Shutdown Equipment*—Requirements for the auto-

matic control of the power supply include:

A1.3.1 Detection of an open-circuit in any wire of the test specimen,

A1.3.2 Current limiting with circuit breakers (or equivalent) of the size normally used for the wire in the test,

A1.3.3 Indication that the current limiting device (circuit breaker) has opened,

A1.3.4 Ability to start and stop a timer,

A1.3.5 Ability to keep power available for at least 10 s after an open-circuit or over-current condition is detected, and

A1.3.6 A means to apply the power initially and to reapply the power after a fault as required by this method.

A1.3.7 *Open Circuit Detection*—Connect each powered wire at the LOAD end of the specimen to one terminal of the ac side of a bridge rectifier. Connect the other ac terminal of the rectifier to the NEUTRAL connection at the power supply. Connect the coil of a 120V dc relay to the dc side of the

<sup>20</sup> Model 33-004 or 33-006, 60-400 Hz Frequency Converters, Georator Corporation, 9617 Center Street, Manassas, VA 22110 are suitable.

<sup>21</sup> Ohmite Manufacturing Company, Skokie, IL 60076 makes suitable 1 ohm, 200 watt resistors as Catalog No. C200K1R0.

rectifier. Connect a 25 to 60 watt load with an indicator lamp across each relay coil to show when that coil is powered. (See Ry2-13 in Fig. 23.)

A1.3.8 *Overcurrent Protection*—Provide a 7.5 A circuit breaker, Mil-C-5809,<sup>22</sup> for each powered wire of the test specimen. Do not install a circuit breaker in the neutral wire.

A1.3.9 *Short Circuit Detection*—Connect the ac side of a rectifier bridge across the terminals of each circuit breaker. Connect the dc side to the coil of a 120 V dc relay so that the relay will actuate, if the circuit breaker opens and a voltage appears across it.

A1.3.10 *Power Control*—Connect the NORMALLY OPEN contacts of the Open-Circuit Detection relays in series. Likewise connect the NORMALLY CLOSED contacts of the Short-Circuit Detection relays in series. Connect these two relay loops in series to a time-delay relay that controls the Disconnecting Means and timer. (See the schematic diagram in Fig. 23.)

A1.3.11 *Time-Delay Relay*—Connect a Delay-to-release Time-Delay relay<sup>23</sup> to keep the power applied to the test specimen (those individual wires served from untripped circuit breakers) for at least 10 s after the detection circuits are activated. (This delay permits any additional electrical activity to take place.)

A1.3.12 *Start-Stop Switches*—Provide a momentary switch to apply power initially and to allow the reapplication of power when required by this method. Provide a stop switch for manual control.

A1.4 *Circuit Breaker Proof of Operation*—Provide a means to test periodically the operation of the circuit breakers on overload currents. An approximate 200 % overload (15 A) is adequate and may be obtained with a 1000 watt, 8 ohm resistor. (A readily available 120 V, 1680 watt (13.3 A) room heater also makes a suitable test resistor.)

---

<sup>22</sup> MS22073-7 1/2 (Klixon 7274-11-7 1/2) are suitable.

---

<sup>23</sup> W.W. Grainger Cat No. 6X155 120 V ac 1-180 s Slow Release Relay is suitable.

## A2. VOLTAGE RATING OF HOOK-UP WIRE

A2.1 The continuous voltage rating of an insulation system is that applied voltage at which the probability of failure due to a voltage related cause during the warranted lifetime of the system and within the bounds of specified service conditions is an acceptable figure.

A2.2 The short-time breakdown voltage of the insulation is only one of the many factors limiting the suitable use voltage. The wall thickness together with the mechanical and physical properties of the insulation are equally important since they provide a safety factor against mechanical damage. However, the wide variety of service conditions for hook-up wire makes it impossible to assign a single voltage rating to any individual hook-up wire construction. Therefore, wherever the knowledge of service conditions is poor, no voltage rating should be assigned.

A2.3 If a voltage rating has been assigned to a wire or class of wires on the basis of insulation thickness or experience in a particular application, do not take that rating as a voltage rating of that wire for general use. For instance, automotive ignition wires are used at several kilovolts, but they are always mounted away from ground so that an electrical discharge does not occur between the wire and ground in application. This example indicates that the safe voltage for use of hook-up wire can be increased radically by changing the conditions of

installation so that the wire is spatially separated from ground. If this practice is used, care must be exercised, for the spacer is the most probable failure path, and its continued dryness and freedom from conductive particulate contamination are essential to the continued reliability of the installation.

A2.4 The partial discharge extinction voltage (PDEV) is that voltage determined by test (See Method D 1868), below which partial discharges are not expected to occur. It is unwise to use wires at voltages above this level as determined by the application or conditions imitating the worst possible geometric arrangements of the wire against ground. Ambient temperature and atmospheric pressure also affect the PDEV. Method D 1868 can provide useful data on the effect of these conditions. Other real-life conditions may include moisture and contaminations. Such conditions can further reduce the maximum suitable operation voltage levels.

A2.5 Most failures follow after mechanical damage (cracking after long-time aging, or sunlight/u.v. exposure or mechanical abuse). In consideration of the complexity of the situation, if a voltage rating is essential, assign it only after careful and thorough testing, including moisture effects, thermal and u.v. aging as well as a review of experience with wire of similar material and design that is operating in the same environment.

**APPENDIXES**

**(Nonmandatory Information)**

**X1. ADDITIONAL MANDREL DIAMETERS AND WEIGHTS FOR SECTION 14.4.4**

X1.1 The following values are suggested if it is necessary to perform evaluations with other than AWG No. 20 or No. 14 as recommended in the method:

| Wire Size,<br>AWG No. | Mandrel Diameter,<br>mm (in.) | Weight, kg (lb) |
|-----------------------|-------------------------------|-----------------|
| 28                    | (10) 3/8                      | 0.10 (0.22)     |
| 26                    | (10) 3/8                      | 0.16 (0.35)     |
| 24                    | (10) 3/8                      | 0.25 (0.55)     |
| 22                    | (13) 1/2                      | 0.40 (0.88)     |
| 18                    | (20) 3/4                      | 1.0 (2.2)       |

**X2. DATA FROM INTERLABORATORY STUDY ON BONDABILITY TEST METHOD**

**X2.1**

Pull-out Strength Data Summary from all  
Laboratories

| Sam-<br>ple | Mean   | Max   | Min  | Stand-<br>ard De-<br>viation | Coeffi-<br>cient of<br>Varia-<br>tion, % |
|-------------|--------|-------|------|------------------------------|--|
| 1           | 85.63  | 128.4 | 66.0 | 15.42                        | 18.0                                     |
| 2           | 83.43  | 122.2 | 55.4 | 20.14                        | 24.1                                     |
| 3           | 131.21 | 200.7 | 92.6 | 21.06                        | 16.0                                     |
| 4           | 93.91  | 143.0 | 72.0 | 19.12                        | 20.329.7                                 |
| 5           | 35.90  | 65.5  | 41.0 | 10.68                        | 26.0                                     |
| 6           | 146.09 | 229.5 | 69.5 | 37.98                        | 18.0                                     |
| 7           | 26.34  | 38.3  | 20.5 | 4.76                         | 12.9                                     |
| 8           | 148.35 | 182.2 | 87.4 | 19.15                        |  |
|             |        |       |      | Average                      | 20.6                                     |
|             |        |       |      | Maximum                      | 29.7                                     |
|             |        |       |      | Minimum                      | 12.9                                     |

**X2.2**

Pull-out Strength Data Summary from All  
Laboratories on Samples Made in Two  
Laboratories

| Samples | Mean   | Max   | Min  | Stand-<br>ard De-<br>viation | Coeffi-<br>cient of<br>Varia-<br>tion,<br>% |
|---------|--------|-------|------|------------------------------|---|
| 5 and 7 | 31.12  | 65.5  | 20.5 | 9.55                         | 30.6  |
| 6 and 8 | 147.22 | 229.5 | 69.5 | 30.10                        | 20.4  |

**X3. DATA FROM INTERLABORATORY STUDY ON THE VERTICAL FLAME TEST**

X3.1 Criteria for pass or fail used for the study are as follows:

X3.1.1 The paper flag must not burn.

X3.1.2 The maximum burn time after each flame application must not exceed 15 s.

X3.1.3 The cotton under the specimen must not burn.

**X3.2 Summary of Results of Vertical Flame Test Study**

| Laboratory | Sample Number |      |      |      |      |
|------------|---------------|------|------|------|------|
|            | 1             | 2    | 3    | 4    | 5    |
| 1          | Fail          | Fail | Pass | Fail | Pass |
| 2          | Pass          | Fail | Pass | Fail | Pass |
| 3          | Fail          | Fail | Pass | Fail | Pass |
| 4          | Fail          | Fail | Pass | Fail | Pass |

**X4. COMMONLY USED FLUIDS FOR IMMERSION TESTING**

X4.1 Other fluids which are pertinent to the intended use may also be used.

X4.2 See Test Method D 471 for description of three standard petroleum base oils and four standard reference fuels.

X4.3 See Test Method D 543 for an extensive list of standard reagent chemicals.

X4.4 Fluids described by military specifications are as follows:

|             |   |
|-------------|---|
| MIL-G-5572  | Gasoline, Aviation, Grade 100/130                                     |
| MIL-H-5606  | Hydraulic Fluid, Petroleum Base, Aircraft, Missile and Ordnance       |
| MIL-T-5624  | Turbine Fuel, Aviation, Grades JP4 and JP5                            |
| MIL-L-7808  | Lubricating Oil, Aircraft Turbine Engine, Synthetic Base              |
| MIL-A-8243  | Anti-icing and Deicing-Defrosting Fluid                               |
| MIL-L-23699 | Lubricating Oil, Aircraft Turbine Engine, Synthetic Base              |
| MIL-C-25769 | Cleaning Compound, Aircraft Surface, Alkaline Water Base              |
| MIL-C-43616 | Cleaning Compound, Aircraft Surface                                   |
| MIL-H-83282 | Hydraulic Fluid, Fire Resistant, Synthetic Hydrocarbon Base, Aircraft |
| MIL-H-83306 | Hydraulic Fluid, Fire Resistant, Phosphate Ester Base, Aircraft       |

**X5. MANDREL SIZES AND WEIGHTS FOR FLUID IMMERSION WRAP TEST**

Table X5.1

**TABLE X5.1 Suggested Mandrel Sizes and Weights**

| Wire Size, AWG | Mandrel Diameter, mm (in.) | Weight, kg (lb) |
|----------------|----------------------------|-----------------|
| 30             | 4 (0.157)                  | 0.12 (0.26)     |
| 28             | 4 (0.157)                  | 0.12 (0.26)     |
| 26             | 6 (0.236)                  | 0.12 (0.26)     |
| 24             | 6 (0.236)                  | 0.25 (0.55)     |
| 22             | 6 (0.236)                  | 0.25 (0.55)     |
| 20             | 6 (0.236)                  | 1.0 (2.2)       |
| 18             | 9 (0.354)                  | 1.0 (2.2)       |
| 16             | 9 (0.354)                  | 1.0 (2.2)       |
| 14             | 12 (0.472)                 | 1.0 (2.2)       |
| 12             | 12 (0.472)                 | 1.0 (2.2)       |
| 10             | 19 (0.748)                 | 1.0 (2.2)       |
| 8              | 19 (0.748)                 | 1.5 (3.3)       |
| 6              | 25 (0.984)                 | 1.5 (3.3)       |
| 4              | 30 (1.18)                  | 1.5 (3.3)       |
| 2              | 75 (2.95)                  | 2.0 (4.4)       |
| 0              | 100 (3.94)                 | 2.0 (4.4)       |

## X6. FACTORS AFFECTING WET ARC-TRACKING OF INSULATED WIRE

### X6.1 *Background:*

X6.1.1 Frequently wires are in clamped or tied bundles or protective sleeves of various sorts with close contact between the wires for considerable distances. Defects in the wire insulation, such as cracks or pinholes, are rarely found in the wire as manufactured. Defects can develop during installation and from mechanical or chemical action or from aging in service. Even then, defects in individual wires seldom are aligned in such a way to permit voltage failure when the wires are dry (see Note X6.1). However, in operation, a conducting contaminant, such as moisture from condensation combined with salt, may form on the surface of the wire insulation and bridge the space between defects on different wires. Then, a small leakage current, a few mA, will flow along the surface. As localized areas on the surface dry when heated by the current, a small arc will develop across the tiny, dry area. (The Paschen minimum does not apply here.) A multiplicity of these small arcs (scintillation) can produce localized electrically conducting spots on the surface of susceptible materials. In time, the conducting spots may join up to form a conducting “track.” When the track bridges the gap between the defects, a power arc can form, which may then degrade other wires in the bundle so that they too are damaged in a runaway fashion before the circuit protection can interrupt the fault currents. The mechanisms here are not well understood but may involve the nature and thickness of the surface coating and the nature of the gasses evolved (Note X6.2) as arcing occurs.

NOTE X6.1—When dry, actual metal contact is required to cause voltage failure below the Paschen minimum (about 315 V peak or 223 V rms). In service, vibration or other mechanical movement may cause fretting, chafing, or abrasion of the wire insulation, for example, from metal or sharp edges.

NOTE X6.2—Hydrogen, water vapor and some other gasses tend to limit arcing.

X6.1.2 If the insulation is track-resistant, erosion of the insulation may progress quite slowly. Ultimately, contact may be established between two wires so that an arc results. The degree to which this arc may affect associated wires is uncertain. In many or perhaps most cases, adjacent wires are not adversely affected. In other cases, erosion may progress to expose the conductor and then, by electrolytic action, corrode that conductor so that an open circuit results.

X6.1.3 The track resistance of individual materials are evaluated with tests such as Test Method D 2303 and Test Method D 3638. However, these tests for materials are usually not suitable for use on insulation as applied to wire.

X6.1.4 The design and geometry of the test procedure produce the effects described earlier in this appendix in a controllable fashion within 8 h.

X6.2 Of course, there is much more involved in service than can be included in a simple test procedure for wet arc-tracking failure of wire insulation. Some service considerations are described in the following section.

### X6.3 *Operational Considerations:*

X6.3.1 Typical things to consider include available power, operating voltage and frequency (including dc); voltage regulation, stress, and surges.

X6.3.2 The voltage and current during the phenomena leading to failure, the size and regulation of the power source, the circuit (network) parameters and the characteristics of the circuit interruption devices all have an influence. This test for wire can only approximate some of these influences. (It is necessary to make tests on complete systems to attain a fuller understanding).

X6.3.3 The degree of protective enclosure and the means taken to avoid moisture condensation are important.

X6.3.4 Ambient conditions such as altitude (air pressure), temperature, relative humidity, and the presence of various contaminants (see X6.4.2) have an influence.

X6.3.5 Mechanical vibration, abrasion, flexing, and shock applied suddenly or over a period of time may damage insulated wire making it more susceptible to tracking, erosion, and arc failure. Thermal and other types of aging also may be involved. Any of these considerations can produce faults in the wire. The spaced ring cuts on the test specimen represent this condition in a simple fashion (see X6.4.1).

### X6.4 *Possible Influences on Wet Tracking:*

X6.4.1 The number and distribution of cracks and other defects along the wire—in the test, defects in two wires are closely spaced to decrease the time of test for wires which perform well. It is possible to change the spacing in tests for specific purposes.

X6.4.2 The presence of surface moisture from rain, melted snow or ice, condensation, drip from condensation on other objects, or leaks from associated equipment—various kinds of contaminants (which cause conductance) also may be present, such as ionizable salts, acids and bases. Organic components such as oil, starch, and sugars (for example, human and animal wastes) may carbonize under surface scintillation and thereby accelerate tracking and erosion.

X6.4.3 The “wetability” of the insulation (the tendency for moisture or contaminant in solution to spread along the surface of the wire)—many things influence wetability, including the nature of the insulation surface and weathering. Once started, scintillation itself promotes wetability.

X6.4.4 The way the insulation surface degrades under scintillation—some materials degrade to a hard, compact “char” from which electrically conductive tracks (Note X6.3) form readily. Other materials may produce fluffy or powdery type chars which do not form tracks readily. Some materials depolymerize or otherwise produce just gaseous decomposition products. Material composition also influences the rate of erosion. In service, wires with different kinds of insulation may be included in the same bundle. The possibility of interaction between different types of wires must be recognized.

NOTE X6.3—These tracks are often called ‘carbon’ tracks, but different degrees of carbonization (or graphitization) may be involved. Silicones may degrade forming conducting silicon carbide.

*X6.5 Influences on Arc Formation:*

*X6.5.1 Magnitude of available arc power*—current, voltage, and time (see X6.3.2).

*X6.5.2 Conductivity of the arc plasma*—temperature, presence of metal vapor and the nature of the gasses evolved from

the insulation have influence—some gasses tend to propagate the arc while others may quench it.

*X6.5.3 Conductivity of the track*—carbonized residues tend to be very much more conductive when heated by an arc—a very conductive track increases the severity of the arcing.

*ASTM International takes no position respecting the validity of any patent rights asserted in connection with any item mentioned in this standard. Users of this standard are expressly advised that determination of the validity of any such patent rights, and the risk of infringement of such rights, are entirely their own responsibility.*

*This standard is subject to revision at any time by the responsible technical committee and must be reviewed every five years and if not revised, either reapproved or withdrawn. Your comments are invited either for revision of this standard or for additional standards and should be addressed to ASTM International Headquarters. Your comments will receive careful consideration at a meeting of the responsible technical committee, which you may attend. If you feel that your comments have not received a fair hearing you should make your views known to the ASTM Committee on Standards, at the address shown below.*

*This standard is copyrighted by ASTM International, 100 Barr Harbor Drive, PO Box C700, West Conshohocken, PA 19428-2959, United States. Individual reprints (single or multiple copies) of this standard may be obtained by contacting ASTM at the above address or at 610-832-9585 (phone), 610-832-9555 (fax), or service@astm.org (e-mail); or through the ASTM website (www.astm.org).*