



# Standard Test Methods for Fibrous-Insulated Magnet Wire<sup>1</sup>

This standard is issued under the fixed designation D 3353; the number immediately following the designation indicates the year of original adoption or, in the case of revision, the year of last revision. A number in parentheses indicates the year of last approval. A superscript epsilon ( $\epsilon$ ) indicates an editorial change since the last revision or reapproval.

## 1. Scope

1.1 These test methods cover the testing of fibrous-insulated electrical conductors, commonly referred to as magnet wire, which are used in electrical apparatus. The test methods are intended primarily for evaluation of the electrical insulating materials used. It is intended that these test methods be used, except where modified by individual specifications for particular applications.

1.1.1 These test methods apply to those magnet wires that are fiber-covered and in which the conductor may or may not be coated with an underlying insulating film as covered by Test Methods D 1676. Fiber-covered wires are produced by serving helically or wrapping fibers or fibrous-tape insulation uniformly around the wire in single and multiple layers. The served or wrapped materials may be bonded to the underlying wire.

1.2 The values stated in inch-pound units are the standard. The SI equivalents of inch-pound units may be approximate.

1.3 The test methods appear in the following sections:

Procedure	Section
Adhesion and Flexibility	8
Dielectric Breakdown Voltage	9
Electrical Resistance of Conductors	5
Elongation	4
Fibrous Coverage	6
Measurement of Dimensions	7

1.4 *This standard does not purport to address all of the safety concerns, if any, associated with its use. It is the responsibility of the user of this standard to establish appropriate safety and health practices and determine the applicability of regulatory limitations prior to use.* See 8.4.1 and 9.5.1 for specific caution statements.

1.5 This standard and IEC 851 are similar if not equivalent in technical content.

## 2. Referenced Documents

### 2.1 ASTM Standards:

B 193 Test Method for Resistivity of Electrical Conductor Materials<sup>2</sup>

D 149 Test Method for Dielectric Breakdown Voltage and Dielectric Strength of Solid Electrical Insulating Materials at Commercial Power Frequencies<sup>3</sup>

D 1676 Test Method for Film-Insulated Magnet Wire<sup>3</sup>

D 5423 Specification for Forced-Convection Laboratory Ovens for Evaluating Electrical Insulation<sup>4</sup>

E 8 Test Methods for Tension Testing of Metallic Materials<sup>5</sup>

### 2.2 IEC Standard:

IEC 851 Methods of Test for Winding Wires<sup>6</sup>

## 3. Terminology

### 3.1 Definitions of Terms Specific to This Standard:

3.1.1 *serving, n*—a uniform wrapping of fibrous insulation around a magnet wire or bare conductor.

## 4. Elongation

4.1 *Scope*—This test method covers the determination of the elongation of fibrous insulated magnet wire that results in a fracture of the conductor.

4.2 *Significance and Use*—The elongation determined by this test method provides a general measure of the ductility of the conductor and the effect of the processing to which it has been subjected during the insulating operation.

4.3 *Apparatus*—The equipment shall have a minimum separation of 10 in. (254 mm) between grips, and be capable of elongating the specimen to its breaking point, at a constant rate of  $12 \pm 1$  in./min ( $305 \pm 25$  mm/min). The equipment shall be such that the error of the length measurement will be 1 % or less. Suitable, non-slip grips are required that will not damage the specimen in the region of elongation. Drum or capstan type grips have been found to be unsatisfactory.

NOTE 1—See Test Methods E 8 for a discussion of machines, gripping devices, and rates of stressing.

### 4.4 Procedure:

4.4.1 Remove the fibrous insulation without distorting the conductor for wire sizes 0.0253 in. (0.6426 mm) (AWG 22) and finer. The insulation need not be removed from sizes larger than 0.0253 in.

<sup>1</sup> These test methods are under the jurisdiction of ASTM Committee D-9 on Electrical and Electronic Insulating Materials and are the direct responsibility of Subcommittee D09.10 on Magnet Wire Insulation.

Current edition approved May 10, 1998. Published March 1999. Originally published as D 3353 – 74. Last previous edition D 3353 – 92 (1995) <sup>$\epsilon$ 1</sup>.

<sup>2</sup> *Annual Book of ASTM Standards*, Vol 02.03.

<sup>3</sup> *Annual Book of ASTM Standards*, Vol 10.01.

<sup>4</sup> *Annual Book of ASTM Standards*, Vol 10.02.

<sup>5</sup> *Annual Book of ASTM Standards*, Vol 03.01.

<sup>6</sup> Available from International Engineering Consortium, 549 West Randolph Street, Suite 600, Chicago IL 60661–2208.

4.4.2 *Standard Method*: Insert the test specimen into the grips resulting in an original length of  $10 \pm 0.1$  in. ( $254 \pm 2.5$  mm) being stretched. Elongate the wire at a constant rate of  $12 \pm 1$  in./min ( $305 \pm 25$  mm/min) until the conductor breaks. Determine the length at break by measuring the final distance between the grips. Discard the results for any specimens that break within  $\frac{1}{4}$  in. (6 mm) of the grips. When breaks occur frequently in this manner, a need for modification of the equipment or technique is indicated.

4.4.3 *Bench Mark Method*: Rectangular, square, and round wire larger than 0.0651 in. (1.654 mm) in diameter can be tested using bench marks. Measure the original length between bench marks to ensure the distance between the bench marks is  $10 \pm 0.1$  inches ( $254 \pm 2.5$  mm). Insert the wire specimen into the grips and locate the bench marks centrally and not more than 1 inch (25.4 mm) from either grip. Elongate the wire specimen at a constant rate of  $12 \pm 1$  inch/min ( $305 \pm 25$  mm/min) until the conductor breaks. Match the broken ends of the specimen, place together, and measure the final length at break between the bench marks. In order to minimize the effect of local variations in the wire under test, test three specimens of the sample. Discard the results for any specimens that break within  $\frac{1}{4}$  in. (6 mm) of the grips or the bench marks. When breaks occur frequently in this manner, a need for modification of the equipment or technique is indicated.

4.5 *Calculation*—Calculate the elongation as follows:

$$\text{Elongation, \%} = [(A - B)/B] \times 100 \quad (1)$$

where:

$A$  = length at break, and

$B$  = original length

4.6 *Report the following information*:

4.6.1 Bare conductor dimensions,

4.6.2 Bare conductor material,

4.6.3 Type and build of film insulation,

4.6.4 Type of fibrous-insulation,

4.6.5 Number of servings,

4.6.6 Direction of servings,

4.6.7 Type of varnish,

4.6.8 Whether or not bench marks are used, and

4.6.9 Individual and average elongation.

4.7 *Precision and Bias*:

4.7.1 This test method has been in use for many years, but no statement of precision has been made and no activity is planned to develop such a statement.

4.7.2 No information can be presented on the bias of this procedure in Section 4, for measuring the percent elongation, as no material having an accepted reference value is available.

## 5. Electrical Resistance of Conductors

5.1 *Scope*—This test method covers the determination of the electrical resistance of fibrous insulated magnet wire conductors.

5.2 *Significance and Use*—Accurate control of resistance is necessary to meet apparatus design parameters. Resistance is expressed in terms of ohms per unit length corrected to 20°C (68°F) and is a function of conductor dimensions, resistivity, and temperature. Resistance may be affected by the processing operation.

5.3 *Apparatus*—The types of apparatus utilized for measuring resistance and length are specified in Test Method B 193.

5.4 *Procedure*—Remove the insulation on both ends of the test specimen for electrical contact. The cleaning operation must not affect the conductor dimensions. Determine the electrical resistance of the test specimen.

NOTE 2—For the fine magnet wires electrical contact of the test specimen may be obtained by soldering to prepared terminals on the measuring apparatus.

NOTE 3—While balancing the bridge, care must be taken to prevent excessive heating of the specimen as a result of prolonged current flow, and to avoid changes in temperature due to air drafts or to variations in ambient conditions.

5.5 *Report the following information*:

5.5.1 Bare conductor dimensions,

5.5.2 Bare conductor material,

5.5.3 Type and build of film insulation,

5.5.4 Type of fibrous-insulation,

5.5.5 Number of servings,

5.5.6 Direction of servings,

5.5.7 Type of varnish,

5.5.8 Test temperature,

5.5.9 Specimen length,

5.5.10 Apparatus used,

5.5.11 Resistance reading, and

5.5.12 Resistance ohms per unit length corrected to 20°C (68°F).

5.6 *Precision and Bias*—

5.6.1 This test method has been in use for many years, but no statement of precision has been made and no activity is planned to develop such a statement.

5.6.2 No information can be presented on the bias of this procedure in Section 5, for measuring the electrical resistance of the conductor, as no material having an accepted reference value is available.

## 6. Fibrous Coverage

6.1 *Scope*—This test method covers the determination of the quality of fibrous servings on round magnet wire or bare conductor.

6.2 *Definition of Term Specific to This Standard*:

6.2.1 *fibrous coverage, n—of served-magnet wire*, that characteristic which allows a fibrous served magnet wire to be wound around mandrels in a prescribed manner without causing observable openings in the fibrous coverage.

6.3 *Significance and Use*—The results of this test are indicative of the quality of the fibrous servings applied to the wire. High quality serving is required since it will permit the wire to be stressed by bending without exposing the conductor or underlying film.

6.4 *Apparatus*:

6.4.1 Means for chucking and rotating mandrels while maintaining suitable wire tension.

6.4.2 *Mandrels*, to be specified.

NOTE 4—Commercially, it is normally specified that the bare conductor or underlying film shall not be exposed when the specimen is wound around a mandrel having a diameter ten times the diameter of the bare conductor.

6.5 Procedure:

6.5.1 Wind the wire, with only sufficient tension to form it around a mandrel of a diameter to be specified, without twisting or stretching and at a speed not to exceed 40 rpm. Ten turns closely spaced along the mandrel shall constitute a test specimen.

6.5.2 Examine the test specimen for exposed bare conductor or underlying film with normal vision under a minimum light level of 100 fc(1klx).

6.6 Report the following information:

- 6.6.1 Bare conductor dimensions,
- 6.6.2 Bare conductor material,
- 6.6.3 Type and build of film insulation,
- 6.6.4 Type of fibrous-insulation,
- 6.6.5 Number of servings,
- 6.6.6 Direction of servings, and
- 6.6.7 List the smallest mandrel diameter that does not expose the bare conductor or underlying film.

6.7 Precision and Bias—

6.7.1 No information is presented about either the precision or bias of Section 6 for evaluating fibrous coverage since the test result is nonquantitative.

7. Measurement of Dimensions

7.1 Scope:

7.1.1 These test methods determine the dimensions of the bare conductor and the fibrous-insulated magnet wire.

7.1.1.1 The micrometer technique is applicable to wires where compressibility of the conductor or insulation is not a factor.

7.1.1.2 The tapered mandrel technique is suitable for measuring the diameter of wires where compressibility is a factor as in stranded or litz wire, or where the insulating material may be readily distorted as in the case of some organic fibers.

7.2 Significance and Use—Knowledge of the dimensions of the bare conductor, overall dimensions of fibrous-insulated magnet wire, and average insulation addition to the dimensions are necessary for specification and use purposes. Bare conductor dimensions are one of the basic parameters used in the design of electrical machinery and the breakdown voltage is related to the thickness of the insulation.

7.3 Apparatus:

7.3.1 Micrometer, apparatus for measuring the dimensions of bare conductor and fibrous-insulated wire shall consist of accurate hand or bench micrometers. The micrometer spindle loading shall not be greater than 8 oz/1/4-in. diameter anvil (225 g/6.36-mm diameter anvil) for 0.0651 in. (1.654 mm) (AWG 14) and finer. For all round wire sizes larger than 0.0651 in. (1.654 mm) and for all rectangular and square wire sizes, the micrometer spindle loading shall be 3 lb ± 1 oz/1/4-in. diameter anvil (1360 ± 28 g/6.36-mm diameter anvil).

NOTE 5—Other instruments such as electronic micrometers or light wave micrometers may be used for measuring bare conductor diameter.

NOTE 6—Spindle pressures specified above have been established based on experience with copper. Reduced pressures may be required for other metals.

7.3.2 Mandrel, tapered (Fig. 1).

7.3.3 Weights, suitable (Table 1).

7.3.4 Calipers, precision, with vernier reading to 0.001 in. (0.025 mm).

7.4 Specimens:

7.4.1 When using the micrometer technique, the test specimens shall consist of at least 3 in. (76 mm) straight lengths of wire free of kinks or obvious defects. Carefully remove the specimens from the spool or container at 1 ft (0.3 m) intervals without more than 1 % stretch for straightening.

7.4.2 When measuring the diameter using the tapered mandrel technique, the specimen shall be of sufficient length to wind a minimum of 25 turns on the tapered mandrel and shall be free of kinks or other obvious defects. Carefully remove the specimens from the spool to avoid damaging or stretching.

7.5 Procedure:

7.5.1 For round wire, using a micrometer, measure the overall diameter at four places approximately 45° apart around the specimen. The average of the high and low values shall be the overall or specimen diameter.

7.5.2 For round wire, using the tapered mandrel technique, attach one end of the specimen to the small end of the mandrel, pass the wire over a pulley as indicated in Fig. 2 and attach the free end of the wire to the load specified in Table 1. Closely wind a minimum of 25 turns onto the tapered mandrel at the

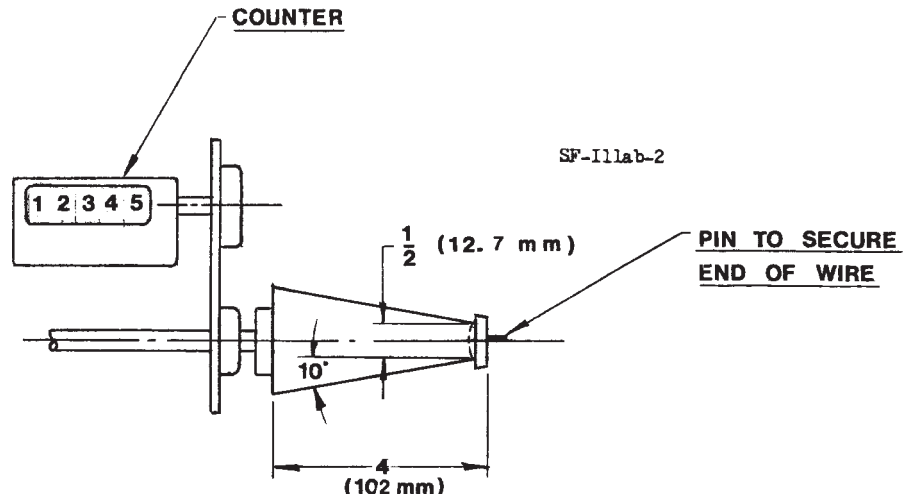

FIG. 1 Tapered Mandrel

TABLE 1 Copper Wire Tension<sup>A</sup>

AWG Size	Nominal Bare Diameter		Tension to Produce 7500 psi (52 MPa)	
	in.	mm	lb	kg
22	0.0253	0.6426	3.8	1.75
23	0.0226	0.5740	3.0	1.50
24	0.0201	0.5105	2.4	1.10
25	0.0179	0.4547	1.9	0.85
26	0.0159	0.4039	1.5	0.70
27	0.0142	0.3607	1.2	0.55
28	0.0126	0.3200	<sup>B</sup>	0.45
29	0.0113	0.2870	<sup>B</sup>	0.35
30	0.0100	0.2540	<sup>B</sup>	0.27
31	0.0089	0.2261	<sup>B</sup>	0.21
32	0.0080	0.2032	<sup>B</sup>	0.17
33	0.0071	0.1803	<sup>B</sup>	0.14
34	0.0063	0.1600	<sup>B</sup>	0.11
35	0.0056	0.1422	<sup>B</sup>	0.085
36	0.0050	0.1270	<sup>B</sup>	0.065
37	0.0045	0.1143	<sup>B</sup>	0.055
38	0.0040	0.1016	<sup>B</sup>	0.045
39	0.0035	0.0889	<sup>B</sup>	0.035
40	0.0031	0.0787	<sup>B</sup>	0.025
41	0.0028	0.0711	<sup>B</sup>	0.020
42	0.0025	0.0635	<sup>B</sup>	0.017
43	0.0022	0.0559	<sup>B</sup>	0.013
44	0.0020	0.0508	<sup>B</sup>	0.011

<sup>A</sup>Wire tensions for materials other than copper have not been established.

<sup>B</sup>For weights less than 1 lb (0.45 kg) use specified kilogram values.

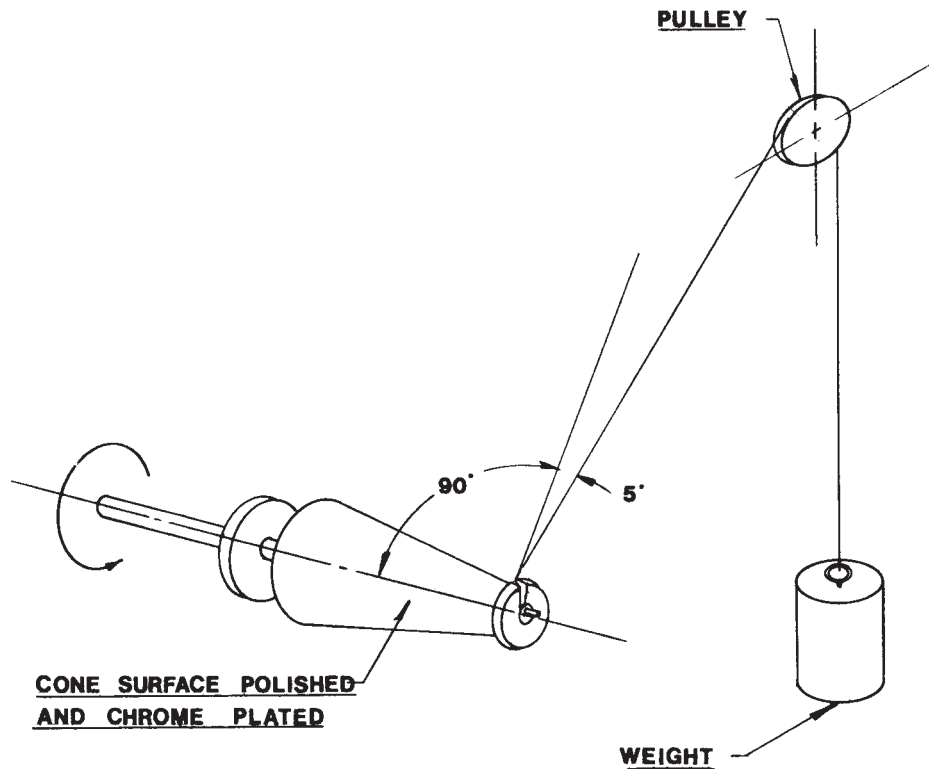

FIG. 2 Mandrel and Pulley

rate of approximately 12 rpm. Measure the length of the winding along the mandrel with a vernier caliper and divide this distance by the number of turns along the mandrel. The quotient is the average overall diameter of the wire.

7.5.3 For rectangular wire, measure the overall thickness and width for each of three specimens. On square wire, mark one side to insure that the measurement will be taken on the same sides on both the insulated wire and bare conductor. The

average of the three thicknesses and width measurements shall be the overall thickness or width, or both.

7.5.4 Remove the fibrous insulation without distorting the conductor and measure the diameter or thickness and width as in 7.5.1 and 7.5.3. In the case of stranded or litz wire it may be desirable to measure the conductor diameter as described in 7.5.2.

7.5.5 When an insulating film underlies the fibrous insulation, remove it by chemical means without distorting the conductor and measure the diameter or thickness and width as in 7.5.1 and 7.5.3.

**NOTE 7**—If there is a question of a chemical stripper removing some of the bare conductor, immerse a piece of the bare conductor of known dimensions in the stripper for the same length of time, remove, wash off, dry and remeasure. If a measurable amount of bare conductor is removed, a different stripper must be used or a correction applied. Enamel films may also be removed from copper by flame followed by immediate immersion in a low-boiling alcohol such as methyl or ethyl alcohol or mixtures of these and water.

7.5.6 For round wire with an underlying film, subtract the minimum allowable diameter of the film-insulated magnet wire from the average overall diameter. Report this as the increase in diameter due to fibrous insulation.

7.5.7 For rectangular and square wire with an underlying film, subtract the minimum allowable increase in dimensions of the film-insulated magnet wire from the average overall dimensions. Report these as the increase in dimensions due to fibrous insulation.

7.6 Report the following information:

- 7.6.1 Bare conductor dimensions,
- 7.6.2 Bare conductor material,
- 7.6.3 Type and build of film insulation,
- 7.6.4 Type of fibrous-insulation,
- 7.6.5 Number of servings,
- 7.6.6 Direction of servings,
- 7.6.7 Type of varnish,
- 7.6.8 Average dimensions of fibrous-insulated wire,
- 7.6.9 Minimum allowable increase in dimensions of film insulation,
- 7.6.10 Average dimensions of bare conductor,
- 7.6.11 Minimum and maximum overall dimensions, and
- 7.6.12 Average increase in dimensions due to fibrous-insulation.

7.7 Precision and Bias—

7.7.1 This test method has been in use for many years, but no statement of precision has been made and no activity is planned to develop such a statement.

7.7.2 No information can be presented on the bias of this procedure in Section 7, for measuring the dimensions of fibrous magnet wire, as no material having an accepted reference value is available.

## 8. Adhesion and Flexibility

8.1 Scope—This test method covers the evaluation of the flexibility and adherence of varnished fibrous glass, and varnished or unvarnished fibrous polyester-glass insulating material on either bare conductor, or film-insulated magnet

wire. Because the properties are interrelated, they are evaluated by elongation or a combination of elongation and mandrel tests.

8.2 Significance and Use—During the winding of magnet wire into electrical apparatus, some elongation of the fibrous insulation serving occurs. Good insulation flexibility and adherence are essential to maintain the integrity of the fibrous covering. Because these properties depend on the proper serving of the fibrous material, the proper softening of the polyester, when used, as well as the proper varnishing of the surface, when used, evaluation of these properties gives an indication of the quality of the insulated wire.

8.3 Apparatus:

8.3.1 Means for Chucking and Rotating Mandrels, while maintaining sufficient wire tension without elongating the test specimen.

8.3.2 Mandrels, of the diameter specified.

8.3.3 Equipment, for elongating the wire to a predetermined amount at a specified rate.

8.3.4 Container, insulated from ground, filled with 0.080 to 0.110 in. (2.0-2.8 m) in diameter lead or nickel-plated shot.

8.3.5 Transformers, Circuit Breaker, Voltage Control and Voltmeter, conforming to the requirements of Test Method D 149.

8.4 Procedure:

8.4.1 **Caution: High Voltage**

8.4.1.1 Lethal voltages are a potential hazard during the performance of this test. It is essential that the test apparatus, and all associated equipment electrically connected to it, be properly designed and installed for safe operation.

8.4.1.2 Solidly ground all electrically conductive parts which it is possible for a person to contact during the test.

8.4.1.3 Provide means for use at the completion of any test to ground any parts which were at high voltage during the test or have the potential for acquiring an induced charge during the test or retaining a charge even after disconnection of the voltage source.

8.4.1.4 Thoroughly instruct all operators as to the correct procedures for performing tests safely.

8.4.1.5 When making high voltage tests, particularly in compressed gas or in oil, it is possible for the energy released at breakdown to be sufficient to result in fire, explosion, or rupture of the test chamber. Design test equipment, test chambers, and test specimens so as to minimize the possibility of such occurrences and to eliminate the possibility of personal injury. If the potential for fire exists, have fire suppression equipment available.

8.4.2 For glass-fiber-covered and polyester-glass-fiber-covered rectangular and square wire without an underlying film-insulation, and with or without a varnish surface treatment, bend a specimen flatwise 180° around a mandrel having a diameter ten times the thickness of the bare conductor.

8.4.2.1 Bury the bent portion of the specimen in the lead shot, and apply test voltage between the conductor and the lead shot. Starting at zero, increase the voltage uniformly at the rate of  $500 \pm 10\%$  V/s until the insulation is punctured. The fault current of the circuit shall be a minimum of 1.5 milliamperes. Read the maximum root-mean-square voltage attained. If the

breakdown occurs in less than 5 s, repeat the test with the rate of voltage rise decreased sufficiently so that breakdown occurs in not less than 5 s.

8.4.3 For glass-fiber-covered and polyester-glass-fiber-covered rectangular and square wire with an underlying film coating, and with or without a varnish surface treatment, elongate a specimen having an effective length of  $10 \pm 0.1$  in. ( $254 \pm 2.5$  mm) at least 20 % at a rate of  $12 \pm 1$  in. ( $305 \pm 25$  mm)/min.

8.4.3.1 Examine the elongated specimen using normal vision, and without removal of the glass-fiber, or polyester-glass-fiber covering for openings in which the bare conductor is visible.

8.4.4 Wind a specimen of glass-fiber-covered or polyester-glass-fiber-covered round wire with or without an underlying film-insulation three turns around a mandrel having the diameter specified as follows:

	AWG Size	Mandrel Diameter
Glass fiber	0 and larger	15×
Glass fiber	1 to 30	10×
Polyester glass fiber	all	5×

8.4.4.1 Examine the specimen with normal vision, for openings in the glass-fiber or polyester-glass-fiber covering that expose the bare conductor or film-insulated wire.

8.4.5 Elongate a specimen of polyester-glass-fiber-covered round wire having an effective length of  $10 \pm 0.1$  in. ( $254 \pm 2.5$  mm), 25 % or to its breaking point, whichever is less, at a rate of  $12 \pm 1$  in. ( $305 \pm 25$  mm) / min.

8.4.5.1 Examine the specimen with normal vision, for loosening, fraying or loss of adherence of the covering except at the point of rupture.

8.5 Report the following information:

- 8.5.1 Bare conductor dimensions,
- 8.5.2 Bare conductor material,
- 8.5.3 Type and build of insulation,
- 8.5.4 Number of servings,
- 8.5.5 Direction of servings,
- 8.5.6 Type of varnish,
- 8.5.7 Number of specimens tested,
- 8.5.8 Dielectric breakdown voltage measured on 8.4.2.1,
- 8.5.9 Any openings found in 8.4.3.1,

8.5.10 Any exposed bare conductor or film-insulated wire found in 8.4.5.1, and

8.5.11 Any loosening, fraying or loss of adhesion found in 8.4.6.1.

8.6 Precision and Bias—

8.6.1 No information is presented about either the precision or bias of Section 8 for evaluating adhesion and flexibility since the test results are nonquantitative.

## 9. Dielectric Breakdown Voltage

9.1 Scope—This test method covers the determination of the dielectric breakdown voltage in air of insulation on round, rectangular, and square wires at commercial power frequencies. Included are “twisted pair” and “layer to layer” tests for round fibrous-insulated magnet wire having diameters 0.0020 to 0.1019 in. (0.05 to 2.59 mm) (AWG 44 to 10) inclusive, and a wrapped foil test for rectangular and square fibrous-insulated magnet wire and round fibrous-insulated magnet wire having a diameter greater than 0.1019 in. (2.59 mm) (AWG 10).

NOTE 8—For a more complete discussion of the scope and significance of dielectric breakdown, see Test Method D 149.

9.2 Apparatus:

9.2.1 Transformer, Circuit Breaker, Voltage Control, and Voltmeter conforming to the requirements of Test Method D 149.

9.2.2 Electrodes, 0.25-in. (6.4-mm) wide foil of suitable materials such as 0.001 in. (0.025 mm) thick aluminum or 0.005 in. (0.125 mm) thick lead.

9.2.3 Weights and Mandrels, as shown in Table 2.

9.2.4 Equipment for Preparing Twisted-Pair Specimens—(see Fig. 3).

9.2.5 Thermometer.

9.2.6 Forced Air Oven in accordance with Specification D 5423 Type 1 or 2.

9.3 Test Specimen:

9.3.1 Twisted Pair (Round Wire)—Form a sample of wire into a “U” shape and place it over the hook of a specimen winder as shown in Fig. 3. Apply tension to each leg of the specimen as specified in Table 2. Twist the specimen according to the number of twists designated in Table 2, under tension,

**TABLE 2 Weights and Mandrels for Dielectric Breakdown Test**

Nominal Bare Wire Size <sup>A</sup>			Wound Pair Weight per Wire		Number of Twists	Layer-to-Layer Test			
						Winding Tension, max		Mandrel Diameter	
in.	mm	AWG	lb	kg		lb	kg	in.	mm
0.1019 to 0.0907	2.588 to 2.304	10 to 11	12	5.4	3	12	5.4	1.00	25.0
0.0808 to 0.0641	2.052 to 1.628	12 to 14	6	2.7	4	6	2.7	1.00	25.0
0.0571 to 0.0453	1.450 to 1.151	15 to 17	3	1.35	6	3	1.35	1.00	25.0
0.0403 to 0.0320	1.024 to 0.813	18 to 20	1.5	0.70	8	1.5	0.70	1.00	25.0
0.0285 to 0.0226	0.724 to 0.574	21 to 23	<sup>B</sup>	0.35	12	<sup>B</sup>	0.35	1.00	25.0
0.0201 to 0.0159	0.511 to 0.404	24 to 26	<sup>B</sup>	0.17	16	<sup>B</sup>	0.17	0.25	6.0
0.0142 to 0.0113	0.361 to 0.287	27 to 29	<sup>B</sup>	0.085	20	<sup>B</sup>	0.085	0.25	6.0
0.0100 to 0.0080	0.254 to 0.203	30 to 32	<sup>B</sup>	0.040	25	<sup>B</sup>	0.040	0.25	6.0
0.0071 to 0.0056	0.180 to 0.142	33 to 35	<sup>B</sup>	0.020	31	<sup>B</sup>	0.020	0.25	6.0
0.0050 to 0.0040	0.127 to 0.102	36 to 38	<sup>B</sup>	0.010	36	<sup>B</sup>	0.010	0.25	6.0
0.0035 to 0.0028	0.089 to 0.071	39 to 41	<sup>B</sup>	0.005	41	<sup>B</sup>	0.005	0.25	6.0
0.0025 to 0.0020	0.064 to 0.051	42 to 44	<sup>B</sup>	0.003	46	<sup>B</sup>	0.003	0.25	6.0

<sup>A</sup>Prepare test specimens for intermediate diameters in accordance with requirements for next smaller range.

<sup>B</sup>For weights less than 1 lb (0.45 kg), use specified kilogram values.

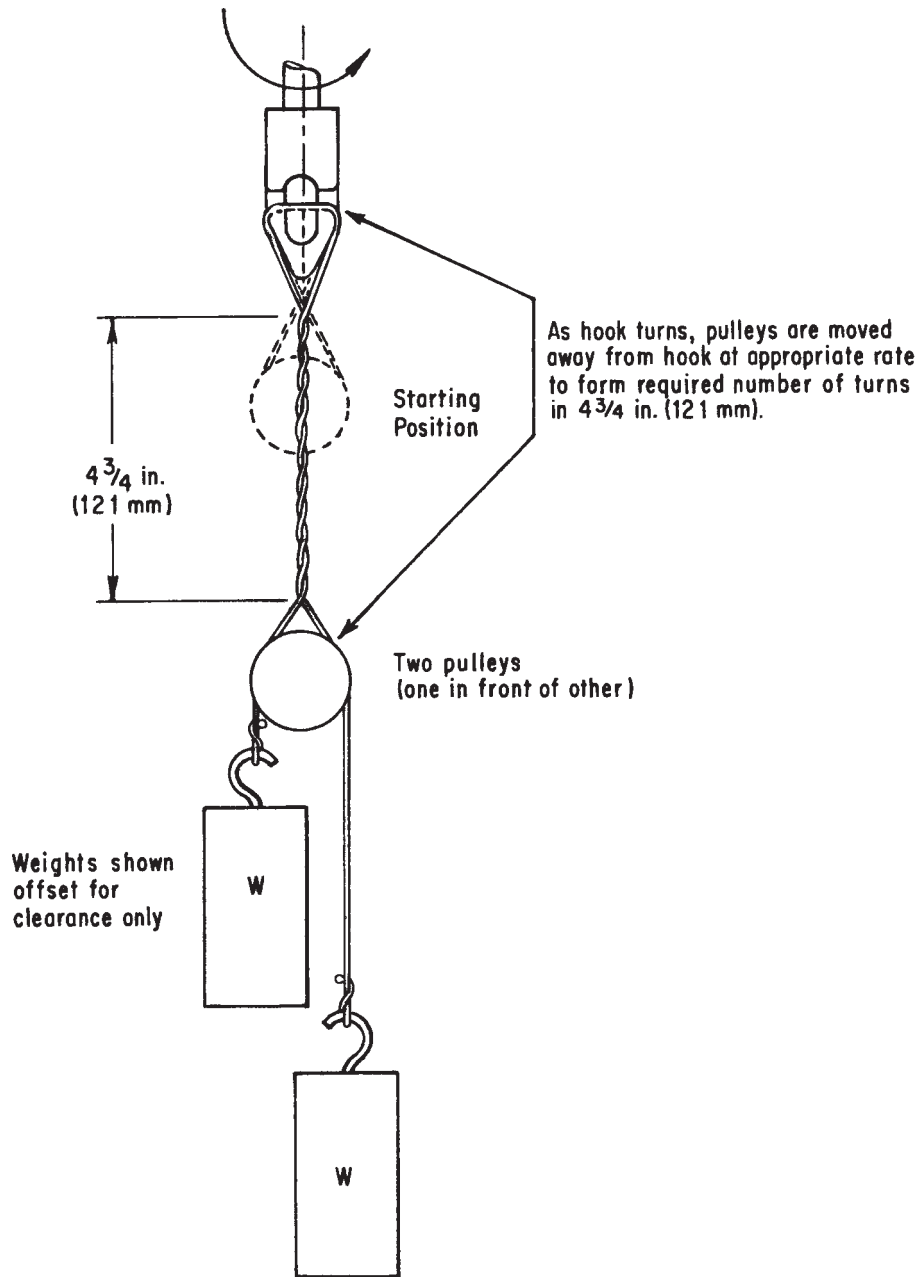

FIG. 3 Served Wire Specimen Winder

without any axial twisting of the wire, and such that the resultant twisted section will be  $4.75 \pm .25$  in. ( $121 \pm 6$  mm) in length. Separate the ends of the specimen to prevent arcing. Avoid any sharp bends or damage to the insulation during preparation of the specimen.

9.3.2 *Layer-to-Layer Test (Round Wire)*— Wind two layers of insulated wire closely, turn to turn, one on top of the other, around a smooth, cylindrical, insulating mandrel, without reversing the direction of winding on the mandrel. The maximum winding tension and mandrel diameters shall be as shown in Table 2. The length of winding along the mandrel shall be  $1 \pm .2$  in. ( $25.4 \pm 5.1$  mm). Secure the ends of each of the windings in such a way that the two layers are

maintained in intimate contact and there is no loosening of the turns. Separate the ends of the wires to prevent arcing.

9.3.3 *Wrapped Foil Test (Round Wire Larger Than 10 AWG, Rectangular, and Square Wires)*—Electrodes shall be prepared by applying a 1/4 in (6 mm) wide thin metal foil to the center of a 1/2 in (12 mm) wide pressure-sensitive tape. The tape shall be cut into strips about 3 in. (76 mm) long. Four of these electrodes shall be applied at right angles to the specimen at intervals of approximately 2 in. (51 mm) and shall be wrapped smoothly and firmly around the specimen a minimum of 1 1/2 complete turns, with the metal surface of the foil in contact with the insulation.

9.4 *Conditioning*—Determine the dielectric breakdown voltage at ambient atmospheric conditions. Should referee tests be required, dry the prepared specimens at  $105 \pm 3^\circ\text{C}$  ( $221 \pm 5^\circ\text{F}$ ) for 48 h and then condition them for not less than 4 h at  $23 \pm 2^\circ\text{C}$  ( $73 \pm 4^\circ\text{F}$ ) and  $50 \pm 5\%$  relative humidity. Make the test at ambient atmospheric conditions immediately after such conditioning.

9.5 *Procedure:*

9.5.1 **Caution:** *High Voltage.*

9.5.1.1 *Lethal voltages are a potential hazard during the performance of this test. It is essential that the test apparatus, and all associated equipment electrically connected to it, be properly designed and installed for safe operation.*

9.5.1.2 *Solidly ground all electrically conductive parts which it is possible for a person to contact during the test .*

9.5.1.3 *Provide means for use at the completion of any test to ground any parts which were at high voltage during the test or have the potential for acquiring an induced charge during the test or retaining a charge even after disconnection of the voltage source .*

9.5.1.4 *Thoroughly instruct all operators as to the correct procedures for performing tests safely.*

9.5.1.5 *When making high voltage tests, particularly in compressed gas or in oil, it is possible for the energy released at breakdown to be sufficient to result in fire, explosion, or rupture of the test chamber. Design test equipment, test chambers, and test specimens so as to minimize the possibility of such occurrences and to eliminate the possibility of personal injury. If the potential for fire exists, have fire suppression equipment available.*

9.5.2 Apply a sinusoidal voltage of commercial power frequency between the electrodes: wires in the case of the twisted pair and layer to layer tests, and the foil electrode and conductor in the case of the wrapped foil test. Starting at zero, increase the voltage uniformly at the rate of  $500 \pm 10\%$  V/s until the insulation is punctured. The fault current of the circuit shall be a minimum of 1.5 milliamperes. Record the maximum root-mean-square voltage reached. If the breakdown occurs in

less than 5 s, repeat the test with the rate of voltage rise decreased sufficiently so that breakdown occurs in not less than 5 s. Make only one test at a time. Use at least three specimens.

NOTE 9—Dielectric breakdown values are affected by the presence of skin oils, acids, salts, dust, dirt, etc. Gloves shall be worn when preparing test specimens or during handling of magnet wire for this test.

9.6 *Referee test*— Should referee tests be required, dry the prepared specimens in a forced air oven at  $60 \pm 3^\circ\text{C}$  ( $140 \pm 5^\circ\text{F}$ ) for  $20 \pm 1$  minutes. Cool the specimens to room temperature. Retest for dielectric breakdown within 1 hour after removal from the oven.

9.7 *Report the following information:*

9.7.1 Bare conductor dimensions,

9.7.2 Bare conductor material,

9.7.3 Type and build of insulation,

9.7.4 Type of fibrous insulation,

9.7.5 Number of servings,

9.7.6 Direction of servings,

9.7.7 Type of varnish,

9.7.8 Number of specimens tested,

9.7.9 Type of test—twist test, layer-to-layer, or wrapped foil,

9.7.10 Breakdown voltage, average, minimum, and maximum, and

9.7.11 Conditioning treatment if used.

9.8 *Precision and Bias*—

9.8.1 This test method has been in use for many years, but no statement of precision has been made and no activity is planned to develop such a statement.

9.8.2 No information can be presented on the bias of this procedure in Section 9, for measuring the dielectric breakdown voltage of the insulation as no material having an accepted reference value is available.

**10. Keywords**

10.1 fiber-covered; fibrous coverage; fibrous insulated; fibrous insulation; fibrous tape insulation; glass fiber; magnet wire; polyester/glass fiber; serving; varnish

*The American Society for Testing and Materials takes no position respecting the validity of any patent rights asserted in connection with any item mentioned in this standard. Users of this standard are expressly advised that determination of the validity of any such patent rights, and the risk of infringement of such rights, are entirely their own responsibility.*

*This standard is subject to revision at any time by the responsible technical committee and must be reviewed every five years and if not revised, either reapproved or withdrawn. Your comments are invited either for revision of this standard or for additional standards and should be addressed to ASTM Headquarters. Your comments will receive careful consideration at a meeting of the responsible technical committee, which you may attend. If you feel that your comments have not received a fair hearing you should make your views known to the ASTM Committee on Standards, at the address shown below.*

*This standard is copyrighted by ASTM, 100 Barr Harbor Drive, PO Box C700, West Conshohocken, PA 19428-2959, United States. Individual reprints (single or multiple copies) of this standard may be obtained by contacting ASTM at the above address or at 610-832-9585 (phone), 610-832-9555 (fax), or service@astm.org (e-mail); or through the ASTM website (www.astm.org).*