



# Standard Test Methods for Physical and Environmental Performance Properties of Insulations and Jackets for Telecommunications Wire and Cable<sup>1</sup>

This standard is issued under the fixed designation D 4565; the number immediately following the designation indicates the year of original adoption or, in the case of revision, the year of last revision. A number in parentheses indicates the year of last reapproval. A superscript epsilon (ε) indicates an editorial change since the last revision or reapproval.

## 1. Scope

1.1 These test methods cover procedures for the physical testing of thermoplastic insulations and jackets used on telecommunications wire and cable and the testing of physical characteristics and environmental performance properties of completed products. To determine the procedure to be used on the particular insulation or jacket or on the completed wire or cable, reference should be made to the specification for that product.

1.2 The test methods appear in the following sections of this standard:

Procedure	Sections
Dimensional measurements of insulations, jackets, miscellaneous cable components, and of completed cable	4-9
Cross-sectional areas	9
Diameters	6
Eccentricity	8
Thickness	7
Physical and environmental tests of insulation and jackets	10-25
Aging test (jackets only)	24
Cold bend (insulation only)	16
Environmental stress crack (polyolefin jackets only)	21
Heat distortion (jackets only)	22
Heat shock (jackets only)	23
Insulation adhesion	19
Insulation and jacket shrinkback (oven test)	14
Insulation compression	20
Insulation shrinkback (solder test)	15
Melt flow rate change—polyolefin materials	12
Oil immersion test (jackets only)	25
Oxygen induction time (polyolefin insulation only)	17
Oxygen induction time (cable filling compound only)	18
Tensile and elongation tests	13
Physical and environmental tests of insulations and jackets of completed wire and cable	26-42
Cable Torsion Test	38
Compound flow test (filled core wire and cable only)	42
Corrugation extensibility test	36
Cable impact test	33
Jacket bonding tests	29

Procedure	Sections
Jacket notch test	32
Jacket peel or pull	28
Jacket slip strength test	30
Pressure test (air core wire and cable only)	40
Sheath adherence test	31
Water penetration test (filled core wire and cable only)	41
Wire and cable bending test	34
Wire breaking strength	37

1.3 The values stated in inch-pound units are to be regarded as the standard except where only SI units are given.

1.4 *This standard does not purport to address all of the safety concerns, if any, associated with its use. It is the responsibility of the user of this standard to establish appropriate safety and health practices and determine the applicability of regulatory limitations prior to use.* For specific caution statement see 19.1.

## 2. Referenced Documents

### 2.1 ASTM Standards:

- D 471 Test Method for Rubber Property—Effect of Liquids<sup>2</sup>
- D 638 Test Method for Tensile Properties of Plastics<sup>3</sup>
- D 1238 Test Method for Flow Rates of Thermoplastics by Extrusion Plastometer<sup>3</sup>
- D 1248 Specification for Polyethylene Plastics Molding and Extrusion Materials<sup>3</sup>
- D 1693 Test Method for Environmental Stress-Cracking of Ethylene Plastics<sup>3</sup>
- D 2633 Test Methods for Thermoplastic Insulations and Jackets for Wire and Cable<sup>4</sup>
- D 3032 Test Methods for Hookup Wire Insulation<sup>4</sup>
- D 3895 Test Method for Oxidative Induction Time of Polyolefins by Differential Scanning Calorimetry<sup>5</sup>
- D 4731 Specification for Hot-Application Filling Compounds for Telecommunications Wire and Cable<sup>4</sup>
- D 4732 Specification for Cool-Application Filling Compounds for Telecommunications Wire and Cable<sup>4</sup>

<sup>1</sup> These test methods are under the jurisdiction of ASTM Committee D-9 on Electrical and Electronic Insulating Materials and are the direct responsibility of Subcommittee D09.18 on Solid Insulations, NonMetallic Shieldings and Coverings for Electrical and Telecommunications Wires and Cables.

Current edition approved March 10, 1999. Published June 1999. Originally published as D 4565 – 86. Last previous edition D 4565 – 94<sup>ε1</sup>.

<sup>2</sup> *Annual Book of ASTM Standards*, Vol 09.01.

<sup>3</sup> *Annual Book of ASTM Standards*, Vol 08.01.

<sup>4</sup> *Annual Book of ASTM Standards*, Vol 10.02.

<sup>5</sup> *Annual Book of ASTM Standards*, Vol 08.02.

E 29 Practice for Using Significant Digits in Test Data to Determine Conformance with Specifications<sup>6</sup>

E 171 Specification for Standard Atmospheres for Conditioning and Testing Materials<sup>7</sup>

2.2 *ANSI Standard*:

ANSI/IEEE Std. 100 IEEE Standard Dictionary of Electrical and Electronics Terms<sup>8</sup>

### 3. Terminology

3.1 *Definitions of Terms Specific to This Standard*:

3.1.1 *air core*—products in which the air spaces between cable core components (pairs, etc.) remain in their unfilled or natural state.

3.1.2 *armored wire or cable*—a wire or cable in which the shielded or jacketed or shielded and jacketed wire or cable is completely enclosed by a metallic covering designed to protect the underlying telecommunications elements from mechanical damage.

3.1.2.1 *Discussion*—Shielding or armoring, or both may be selected from a variety of materials (for example, aluminum, copper, steel) and may be applied in a variety of ways (for example, helically wrapped, longitudinally applied, applied corrugated or smooth).

3.1.3 *cable, telecommunications*—products of six or more pair.

3.1.4 *DOD*—an abbreviation for “Diameter over Dielectric.” This is a short term to refer to the overall diameter over an insulated conductor.

3.1.5 *filled core*—those products in which air spaces are filled with some materials intended to exclude air or moisture, or both.

3.1.6 *gopher-resistant*—a wire or cable that resists the attack of gophers when installed directly buried.

3.1.6.1 *Discussion*—Telecommunications wire and cable products intended for direct burial in the earth are normally rated as either “gopher-resistant” or “non-gopher-resistant.” User selection of products for burial will depend upon the anticipated gopher protection needed for the planned installation site. The gopher-resistant rating is assigned based upon test evaluations (evaluations are commonly performed by the Fish and Wildlife Service, US Department of the Interior, Denver, CO).

3.1.7 *non-gopher-resistant*—a wire or cable that is not designed to resist gopher attack (see 3.1.6).

3.1.8 *pair*—two insulated conductors combined with a twist.

3.1.9 *sheath*—the jacket and any underlying layers of shield, armor, or other intermediate material down to but not including the core wrap.

3.1.10 *shielded wire or cable*—a wire or cable in which the core (or inner jacket) is completely enclosed by a metallic covering designed to shield the core from electrostatic or electromagnetic interference.

3.1.11 *wire, telecommunications*—products containing less than six pair.

## DIMENSIONAL MEASUREMENTS OF INSULATIONS, JACKETS, MISCELLANEOUS CABLE COMPONENTS AND COMPLETED CABLES

### 4. Scope

4.1 Dimensional measurements include, but are not limited to measurements of insulation and jacket thicknesses, tape and armor thicknesses, conductor diameters, DODs, core diameters, overall diameters, etc.

### 5. Significance and Use

5.1 Dimensional measurements, properly interpreted, provide information with regard to the conductors, insulation, or jacket. The dimensional measurements may provide data for research and development, engineering design, quality control, and acceptance or rejection under specifications.

### 6. Diameters

6.1 Measure diameters of essentially round items (such as insulated or uninsulated conductors) using any type of micrometer reading to at least 0.001 in. (0.025 mm) with each division of a width that facilitates estimation of each measurement to 0.0001 in. (0.0025 mm). Take a minimum of two readings, essentially at right angles to each other, and average the results.

6.2 In case of dispute, optical methods as described in Test Methods D 3032 shall be used as the referee method.

NOTE 1—For insulated conductors with dual insulation (for example, foam-skin), the DOD of the inner layer must be measured using the optical methods of Test Methods D 3032.

6.3 Measure the approximate or effective diameters of non-circular cross sections (such as, irregular or oval cables or cable cores) by the use of strap gauges.

6.4 *Precision and Bias*—The precision and bias of this method for measuring diameters are in accordance with Methods D 2633.

### 7. Thicknesses

7.1 Measure insulation thickness using appropriate methods specified in Methods D 2633, except that the micrometer accuracy described in 6.1 is required. Thickness may also be measured using a pin gauge having the accuracy of the micrometers as specified in 6.1, with measurements made on tubular sections of insulation removed from conductors. Optical methods (as specified in 6.2) may also be used.

7.2 Measure jacket thickness using appropriate methods specified in Methods D 2633, except that the micrometer accuracy specified in 6.1 is required. In determining the thickness of jackets applied over corrugated shields or armors, measurements must be made in the corrugation impressions (thinnest jacket spots). Optical methods (as specified in 6.2) may also be used.

7.3 *Precision and Bias*—The precision and bias of this method for measuring thickness are in accordance with Methods D 2633.

<sup>6</sup> *Annual Book of ASTM Standards*, Vol 14.02.

<sup>7</sup> *Annual Book of ASTM Standards*, Vol 15.09.

<sup>8</sup> Available from American National Standards Institute, 11 West 42nd St., 13th Floor, New York, NY 10036.

NOTE 2—For designated purposes (such as, process control, etc.), continuous uniformity thickness gages or measuring devices may be employed during processing to provide running records of jacket thicknesses. Record charts are normally maintained for a minimum of six months.

## 8. Eccentricity

8.1 Calculate eccentricity using measured thickness values for insulation or jacket, or both.

8.2 Calculate absolute eccentricity,  $E_{ab}$ , of insulation or jacket, or both as follows:

$$E_{ab} = (\text{Maximum Thickness}) - (\text{Minimum Thickness}) \quad (1)$$

8.3 Calculate percent eccentricity,  $E_{\%}$ , of insulation or jacket, or both as follows:

$$E_{\%} = \frac{(\text{Max Thickness}) - (\text{Min Thickness})}{(\text{Average Thickness})} \times 100 (\%) \quad (2)$$

8.4 *Precision and Bias*—The precision and bias of this method of measuring eccentricity are in accordance with Methods D 2633.

## 9. Cross-Sectional Areas

9.1 When needed, determine cross-sectional areas (usually insulations or jackets only) using the methods outlined in Methods D 2633, except that the dimensions used in the calculations must be maintained to the accuracy specified in 6.1.

9.2 *Precision and Bias*—The precision and bias of this method for measuring cross-section areas are as specified in Methods D 2633.

## PHYSICAL AND ENVIRONMENTAL TESTS OF INSULATIONS AND JACKETS

## 10. Scope

10.1 Physical and environmental tests for insulations and jackets include, but are not limited to determination of some or all of the properties covered in Sections 12-25.

## 11. Significance and Use

11.1 Physical tests, properly interpreted, provide information with regard to the physical properties of the insulation or jacket. The physical test values give an approximation of how the insulation will physically perform in its service life. Physical tests may provide data for research and development, engineering design, quality control, and acceptance or rejection under specifications.

## 12. Melt Flow Rate Change—Polyolefin Materials

12.1 *Raw Material Baseline*—Melt flow rate for insulation and jacket materials obtained from finished cable must be compared with the flow rates for corresponding raw materials. Determine the flow rates for the basic insulating and jacketing raw materials in accordance with the requirements of Test Method D 1238. Standard conditions of test shall be as prescribed by the product specification. If possible, obtain samples of raw materials before or during the extrusion process (but *not* after heating). Since insulating and jacketing raw

materials are normally obtained and used in bulk, it is usually difficult if not impossible to relate a particular lot of raw material with a particular reel of finished wire or cable; accordingly, average raw materials values may be established as necessary for an appropriate manufacturing time frame, unless otherwise agreed upon between the producer and the purchaser.

12.2 *Insulation Material*—Perform tests on insulation removed from finished conductors. Note that thin wall and fine gauge insulations shall be handled carefully because of entrapped air. In the case of insulation in filled cable, the preferred method is to obtain insulating material from conductors before they are exposed to the filling operation. If necessary, conductors obtained from completed filled cable shall be wiped dry and free of grease or foreign material using a dry cloth (without solvent). Chop the insulation, stripped from a conductor, as necessary to obtain specimens suitable for testing (approximately 3 g of material is required for each test). Test the chopped material as required by Test Method D 1238 to determine a melt flow rate. Run three tests and average the results. Standard conditions of test shall be as indicated in 12.1.

12.3 *Jacket Material*—Jacket material used for this test must be free of filling or flooding compound. Soft filling or flooding compounds may be removed by thoroughly wiping the jacket specimen using a clean dry cloth (without solvent); harder filling or flooding compounds may be removed by cutting. Buffing may be used as a finishing operation to ensure clean and dry specimens. Use jacketing material removed from completed cable for performing tests. Chop the jacket material removed from the cable as is necessary to obtain specimens suitable for testing (approximately 3 g of material is required for each test). Test the chopped material as required by Test Method D 1238 to determine a melt flow rate. Run three tests and average the results. Standard conditions of test shall be as indicated in 12.1.

12.4 *Calculation*—Calculate the percent increase in flow rate as follows:

$$I = \frac{M_2 - M_1}{M_1} \times 100 \quad (3)$$

where:

$I$  = increase, %,

$M_1$  = melt index of raw material, and

$M_2$  = melt index of material from the finished cable.

12.5 *Precision and Bias*—The precision and bias of this method for measuring melt-flow rate changes are basically in accordance with Test Method D 1238.

## 13. Tensile and Elongation Tests

13.1 *Insulation Material*—Provide test specimens by removing insulation from finished conductors. (See Test Specimen section of Methods D 2633 for methods of removing the conductor.) Perform tests in accordance with Test Method D 638 to determine such properties as tensile strength (nominal), yield strength, and percentage elongation at break. The speed of testing shall be as prescribed by the product specifications.

13.2 *Jacket Material*—Provide test specimens by die cutting jacket segments removed (cut) from finished cable. Perform testing in accordance with Test Method D 638 to determine such properties as tensile strength (nominal), yield strength and percentage elongation at break. The speed of testing shall be as prescribed in the product specifications.

13.3 *Precision and Bias*—The precision and bias of these methods for measuring tensile and elongation properties of insulations and jackets are in accordance with Test Method D 638.

#### 14. Insulation and Jacket Shrinkback (Oven Test)

14.1 *Insulation Material*—Perform tests on insulated conductors. Unless otherwise specified, test a minimum of one sample of each color of insulation from a cable. Immediately prior to testing, cut specimens 8 in. (200 mm) long from the center of a 5-ft (1.5-m) length; then reduce them to 6 in. (150 mm) by trimming each end of the specimen. Place these specimens in a forced air type circulating oven or in a forced convection type circulating air oven for 4 h at the temperature prescribed. The specimens shall be placed on a layer of preheated talc or felt. At the end of the conditioning period, cool the wire to room temperature and measure the shrinkback of the insulation. Shrinkback is defined as the total shrinkage of the insulation from both ends of the specimen in inches (or millimetres).

14.2 *Jacket Material*—Perform tests on slabs cut from the cable jacket. Unless otherwise specified, cut a minimum of four test specimens, each 2 in. (51 mm) long, 0.25 in. (6.3 mm) wide, and the same thickness as the jacket. Make the lengthwise cuts parallel to the longitudinal axis of the cable with each specimen spaced circumferentially in 90° increments around the cable periphery. For cables that are longitudinally shielded or armored, one of the specimens shall be cut from a portion of the jacket lying directly over the outer shield or armor overlap. Place these specimens on a layer of preheated talc or felt in a forced-air type circulating oven or in a forced-convection type circulating air oven for 4 h at the temperature prescribed. At the end of the conditioning period, cool the specimens to room temperature and measure the shrinkback of the jacket material. Shrinkback is defined as the total lengthwise shrinkage in inches (or millimetres).

14.3 *Precision and Bias*—No statement is made about either the precision or bias of these methods for measuring shrinkback since the result merely states whether there is conformance to the criteria for success specified in the product specification.

#### 15. Insulation Shrinkback (Solder Test)

15.1 Test specimens of finished insulated conductor for solder shrinkback. Unless otherwise specified, test a minimum of one specimen of each insulation color. Immediately prior to testing, cut 8-in. (200-mm) specimens from the center of a 5-ft (1.5-m) length and then reduce each specimen to 6 in. (150 mm) by trimming each end of the specimen. Using any convenient method, strip 0.5 in. (13 mm) of insulation from one end of the specimen. Using a solder pot maintained at a temperature of approximately 320°C, immerse the bared conductor to a depth of 0.25 in. (6 mm) into the molten solder and

hold for a period of 20 s. Remove the specimen and measure the amount of insulation shrinkback occurring as a result of the heat exposure. Shrinkback in inches (or millimetres) is the total measured length of the bared conductor minus the original length of the bared conductor (0.5 in. (13 mm)).

15.2 *Precision and Bias*—No statement is made about either the precision or bias of this method for measuring shrinkback since the result merely states whether there is conformance to the criteria for success specified in the product specification.

#### 16. Cold Bend (Insulation Only)

16.1 Tests shall be performed on insulated conductors. The insulation shall not show any cracks visible by normal or corrected-to-normal vision, when a specimen of insulated conductor that has been subjected to the specified temperature for 1 h, upon removal from the cooling chamber, is immediately wound around a mandrel at least six adjacent turns. Test temperature and mandrel diameter shall be as prescribed by the product specification. Bending shall be at an approximately uniform rate so that the time consumed is not more than 1 min.

16.2 *Precision and Bias*—The precision of these tests has not been determined. No statement can be made about the bias of this method for insulation cold bend since a standard material is not available.

#### 17. Oxidative Induction Time (Polyolefin Insulation Only)

17.1 *Scope*—This method covers the determination of an Oxidative Induction Time (OIT) value for polyolefin insulation materials removed from completed wire or cable products. This OIT value is determined by a thermoanalytical measurement of the onset time for the exothermic oxidation of insulation in pure oxygen, at a specified temperature. For commentary and additional information on the background, development, and significant details of this test procedure, see Appendix X1.

17.2 *Summary of Test Method*—This method describes the instrument calibration procedures, sample preparation, experimental procedure, and calculation methods for determining OIT values for polyolefin insulation materials. An insulated wire sample is removed from a completed cable/wire product and wiped to remove filling compounds that may be present in the completed cable/wire. Two types of insulation test samples are described: *Type I*—Insulation stripped from wire (no copper present), or *Type II*—Insulation on the wire (insulation and copper conductor).

17.2.1 Use Type I samples to measure the intrinsic stability of the material and the efficacy of thermal stabilizers such as antioxidants.

17.2.2 Use Type II samples to evaluate not only the thermal stability, but also the metal deactivation efficacy of the additives.

17.3 *Significance and Use:*

17.3.1 The OIT value measures the oxidative thermal stability of a material and is primarily dependent on:

17.3.1.1 the intrinsic thermal stability of the material,

17.3.1.2 the type and concentration of antioxidants and other thermal stabilizers present,

17.3.1.3 the type and concentration of metal deactivators present, and

17.3.1.4 the test temperature.

17.3.1.5 *Discussion*—Other components in the insulation material may cause secondary effects. The OIT value for an insulation may be significantly altered by additives such as pigments, fillers, and processing aids as well as catalyst residues from the cable, wire, insulation, or resin manufacture. The OIT value may increase or decrease depending on whether these additives and residues act as oxidation inhibitors or promoters at the test temperature. At typical test temperatures (for example, 170 to 220°C), compounds present in the polyolefin material may decompose and change the polyolefin oxidation mechanism and thereby the OIT value. If the oxidation mechanism is so altered, then the OIT value may not correlate to aging at normal use temperatures. Before using the OIT value to predict field performance and lifetimes, additional studies may be required to establish a correlation between the OIT value measured at high temperature and the performance of the polyolefin under typical field conditions.

17.3.2 The OIT value may be useful as a product performance test, quality control parameter, or a research and development tool for polyolefin materials.

17.4 *Apparatus, Reagents and Materials:*

17.4.1 *Calorimeter*—This OIT Test is performed using commercial analyzers known as Differential Scanning Calorimeters (DSC)<sup>9</sup> which measure heat flow as a function of time and temperature. A DSC with isothermal control and specimen temperature precision of at least  $\pm 0.1^\circ\text{C}$  is required.

NOTE 3—This test requires accurate temperature and atmosphere control in the DSC specimen compartment. DSC manufacturers offer choices in cell configuration and temperature control parameters that may affect this required control. For example, in some power compensation DSCs, use of the two-hole platinum specimen holder lids with a special “flow-through” swing-away block cover is required. Therefore, the user may wish to consult equipment-specific literature and with the equipment manufacturer to optimize the operation of individual DSCs for this test.

17.4.2 *Nitrogen*—Use cylinder nitrogen (99.9 % purity or better) for purging of cells.

17.4.3 *Oxygen*—Use cylinder oxygen (99.9 % purity or better) during the oxidation stage.

NOTE 4—Do not use house gases that are piped throughout buildings since their purity may vary significantly.

17.4.4 *Pans*—Standard aluminum DSC pans (6 mm in diameter) are required to hold specimens during testing.

NOTE 5—Do not use copper pans because the variable oxidation state of the copper leads to imprecision in determination of the OIT value. Do not use metal screens (for example stainless steel mesh) since they can be pro- or anti-oxidants and may reduce precision and accuracy of the OIT measurement.

17.4.4.1 *Degreasing*—To degrease pans, wash in Reagent Grade acetone for 1 min and dry in a stream of dry nitrogen.

Use sufficient acetone to thoroughly wash the pans, that is,  $\sim 200\text{ mL}/100$  pans. Ultrasonic cleaning of the pans in acetone is acceptable.

17.4.5 *Temperature Standards*—Use pure (>99.9 %) indium and tin as temperature calibration standards. See Table 1.

17.4.6 *Balance*—An analytical balance to weigh specimens with a sensitivity of  $\pm 0.1\text{ mg}$  or better.

17.5 *Instrument Calibration*

17.5.1 *Instrument Preparation*—Clean instrument cells between testing of different material formulations. Follow the instrument manual procedure for cleaning cells or hold the cells at  $530^\circ\text{C}$  for 10 min in oxygen.

17.5.2 *Temperature Calibration*—Follow the instrument manual procedures for temperature calibration of the instrument using the following heating programs and calibration criteria.

17.5.2.1 *Indium*—The experimental sequence for the indium calibration is

- (1) Equilibrate at  $50^\circ\text{C}$  (in nitrogen).
- (2) Heat at  $10^\circ\text{C}/\text{min}$  from  $50^\circ\text{C}$  to  $145^\circ\text{C}$ .
- (3) Heat at  $1^\circ\text{C}/\text{min}$  from  $145^\circ\text{C}$  to  $165^\circ\text{C}$ .
- (4) Cool specimen to below  $50^\circ\text{C}$ .
- (5) Repeat steps (1) through (4).
- (6) Use melting temperatures and heat of fusion from second scan for calibration purposes.

17.5.2.2 *Tin*—The experimental sequence for the tin calibration is

- (1) Equilibrate at  $50^\circ\text{C}$  (in nitrogen).
- (2) Heat at  $10^\circ\text{C}/\text{min}$  from  $50^\circ\text{C}$  to  $220^\circ\text{C}$ .
- (3) Heat at  $1^\circ\text{C}/\text{min}$  from  $220^\circ\text{C}$  to  $240^\circ\text{C}$ .
- (4) Cool specimen to below  $50^\circ\text{C}$ .
- (5) Repeat steps (1) through (4).
- (6) Use melting temperatures and heat of fusion from second scan for calibration purposes.

17.5.2.3 *Melting Temperature*—For calibration purposes, define the melting temperature as the extrapolated onset of the melting peak, not the peak maximum (see Fig. 1).

17.5.3 *Calibration Criteria*—An instrument in calibration will validate the melting temperatures of pure indium and pure tin at  $156.6 \pm 0.2^\circ\text{C}$  and  $232.0 \pm 0.5^\circ\text{C}$ , respectively. In addition, the heat of fusion for indium and tin will be  $28.7 \pm 0.8\text{ J/g}$  and  $60.7 \pm 2.0\text{ J/g}$ , respectively. Check the instrument calibration every one to two months or more frequently since this test requires accurate temperature control. (See Note 3.)

17.5.4 *Gas Flow Rate*—Use an oxygen flow rate of  $50 \pm 5\text{ mL}/\text{min}$  as measured with a bubble meter or calibrated rotameter. Other flow rates between 50 and 200 mL/min are permitted, but must be reported.

NOTE 6—It is desirable that the tubing connecting the gas switching point and the calorimeter cell have an inside volume less than 20 mL.

**TABLE 1 Literature Values for Calibration Standards<sup>A</sup>**

Calibration Standard	Melting Temperature, $^\circ\text{C}$	Heat of Fusion (J/g)
	$T_m$	$\Delta H_m$
Indium (In)	156.61	28.7
Tin (Sn)	232.0	60.7

<sup>A</sup> Rossini, F. D., *Applied Chemistry*, Vol 22 1970, p. 557; Gronwold, F., *Acta Chem. Scand.* Vol 21, 1967, p. 1695; Gronwold, F., *J. Therm. Analysis*, Vol 13, 1978, p. 419; Gronwold, F., *Pure and Applied Chemistry*, 1992.

<sup>9</sup> Perkin Elmer's Differential Scanning Calorimeters and TA Instruments Differential Thermal Analyzer with a DSC cell have been found to produce acceptable results. Equivalent equipment producing comparable results may be used.

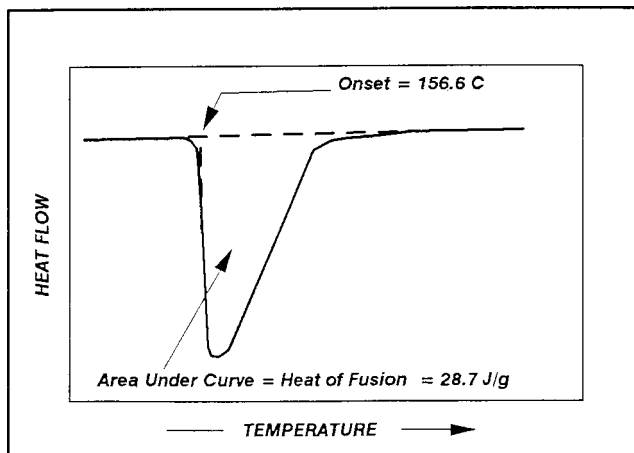

FIG. 1 Indium Calibration

NOTE 7—The average OIT value at 100 mL/min was ~3 % lower than the OIT measured at 50 mL/min. OIT values determined at 100 mL/min had ~5 % improved precision over OIT values obtained at 50 mL/min.

17.5.5 *Test Temperature*—If possible, run a blank specimen to ensure that the instrument can maintain the test temperature within  $\pm 0.3^\circ\text{C}$ . Heat the cell to the desired test temperature (typically  $200^\circ\text{C}$ ) and monitor the specimen temperature for 10 min. If necessary, refer to 17.7.6 for procedural strategies to make the measured specimen temperature equal to the desired test temperature.

17.6 *Sample Preparation*

17.6.1 *Insulated Wire Sample*—Remove the insulated wires from completed wire or cable products by removing the outer cable sheath, inner metallic shields, and any core wraps. Split the outer cable sheath lengthwise, and peel open the sheath and any metallic shields to reveal the inner core with the insulated wire pairs.

17.6.2 *Sample Cleaning*—Wipe the insulated wire sample with a clean cotton cloth or paper towel to remove any filling compound. Do not use solvents to clean the insulated wire.

17.6.3 *Sample Type*—The OIT value for an insulation may be determined using either a: *Type I sample*—Insulation stripped from the copper wire (see 13.1), or *Type II sample*—Insulated wire (insulation and copper wire).

17.6.4 *Specimen/Pan Arrangements*—Use a single 5 to 6-mm long specimen of insulation (or insulated wire). The length is such that the specimen fits neatly into the pan. (See Fig. 2).

17.6.5 *Specimen Weight*—Record the specimen weight to  $\pm 0.1$  mg.

NOTE 8—To determine the insulation sample weight, strip a 100-mm section of the insulated wire and weigh the stripped insulation. Divide the insulation weight by the sample length to determine the insulation weight per mm ( $W_i$ ). Multiplying the specimen length (5 to 6 mm) by this factor ( $W_i$ ) will give the weight for the insulation specimen.

17.7 *Procedure*

17.7.1 *Load Specimens*—Place the specimen (specimen and pan) in the specimen position and an empty aluminum pan in the reference position of the instrument.

17.7.2 *Initial Temperature*—Equilibrate the specimen at or below  $60^\circ\text{C}$ .

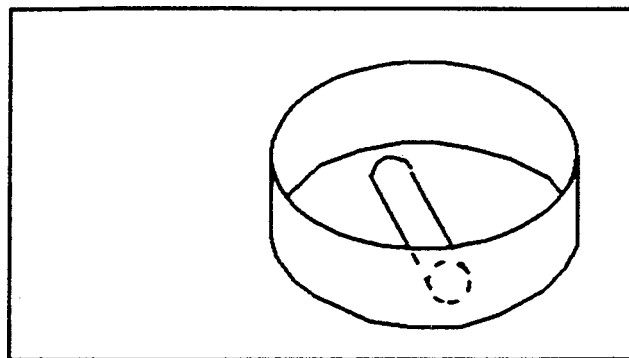

FIG. 2 Specimen/Pan Arrangement

17.7.3 *Flush Cell*—Hold at this initial temperature for 5 min while the nitrogen purge flushes the cell at a flow rate of ~50 to 60 mL/min.

17.7.4 *Heat to Test Temperature*—Heat at  $20^\circ\text{C}/\text{min}$  to the test temperature (typically  $200^\circ\text{C}$ ) with nitrogen gas purging the DSC cell.

NOTE 9—The endothermic peak observed during this heating stage is the melting transition of the polyolefin and can be used for identification (for example, to distinguish between high-density polyethylene, low-density polyethylene, and polypropylenes).

17.7.5 *Gas Switch*—Hold at test temperature for 5 min to establish thermal equilibrium after which switch from the nitrogen purge to pure oxygen at a flow rate of  $50 \pm 5$  mL/min. Define this switch time as  $T_0$ . Measure the Oxidative Induction Time (OIT) from this time ( $T_0$ ).

17.7.6 *Specimen Test Temperature*—If possible, record the specimen temperature 5 min after  $T_0$  with a precision of  $\pm 0.1^\circ\text{C}$  or better. The specimen temperature must be within  $\pm 0.3^\circ\text{C}$  of the desired test temperature. If this temperature is more than  $\pm 0.3^\circ\text{C}$  from the required test temperature, prepare a new specimen and modify the temperature program to ensure OIT measurement is made at the required temperature.

NOTE 10—If  $200.0^\circ\text{C}$  was the desired test temperature and the temperature at  $T_0 + 5$  min was  $200.7^\circ\text{C}$ , then set the upper limit of the temperature program to  $199.3^\circ\text{C}$  to correct for the overshoot of the instrument. Alternatively, monitor and adjust the specimen temperature continuously during the experiment to maintain the desired temperature within  $\pm 0.3^\circ\text{C}$ .

17.7.7 *Specimen Scan*—Continue the test in pure oxygen until the exothermic peak is observed (on the chart recorder or computer screen).

17.7.8 *Data Collection*—Plot the data normalized as heat flow (W/g) versus time. Expand the x-axis as much as possible to facilitate analysis. Vary the y-axis depending on the procedure used to determine the OIT (see 17.8).

17.8 *OIT Calculation*—Use either of the following two procedures to determine the Oxidative Induction Time (OIT) values for the specimens.

NOTE 11—The  $\text{OIT}_1$  calculation uses a threshold measure to define the incipient point for the polyolefin oxidation. The  $\text{OIT}_2$  calculation defines the onset of the major exothermic reaction (that is, the autocatalytic oxidation reaction).

17.8.1 *Procedure 1—OIT<sub>1</sub> (Offset Method)*:

17.8.1.1 Plot data with a full scale y-axis of 1.0 W/g (or smaller). (See Fig. 3.)

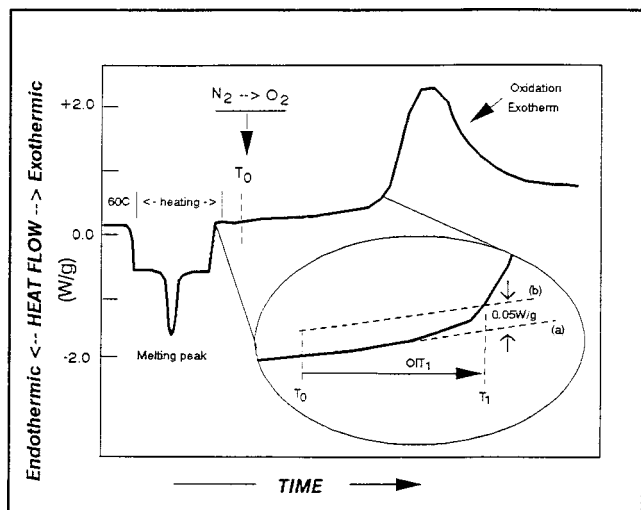

FIG. 3 OIT<sub>1</sub> Offset Method

17.8.1.2 Expand the x-axis so that full scale on the x-axis ranges from  $T_0 - 2$  min to 5 to 10 min past the onset of the oxidation exotherm. This expansion may assist in analysis by the offset procedure.

17.8.1.3 Draw an extension to the baseline extrapolating any instrument drift. For an example see dashed line (a) in Fig. 3.

17.8.1.4 Draw a second line parallel to baseline (a) at a distance of 0.05 W/g above the baseline. See dashed line (b) in Fig. 3.

17.8.1.5 The intersection of the dashed line (b) with the signal trace is defined as the onset of oxidative degradation and is denoted as  $T_1$ .

17.8.1.6 The Oxidative Induction Time by the offset procedure is defined as the time from oxygen introduction ( $T_0$ ) to this onset:

$$OIT_1(\text{offset}) = T_1 - T_0 \quad (4)$$

17.8.2 Procedure 2—OIT<sub>2</sub> (Tangent Method):

17.8.2.1 Plot data with a y-axis sufficient to show full melting endotherm of the polyolefin and the oxidation endotherm. For a 5 mg polyolefin specimen, a y-axis of 4 to 5 W/g is adequate.

17.8.2.2 Draw an extension to the baseline extrapolating any signal drift. For an example see dashed line (c) in Fig. 4.

17.8.2.3 Draw a tangent (dashed line (d) in Fig. 4) at the inflection point of the exothermic peak and extend this tangent to intersect the baseline (c).

17.8.2.4 The point of intersection is the onset of oxidative degradation by the tangent method. This onset time is denoted as  $T_2$ .

17.8.2.5 The Oxidative Induction Time by the tangent procedure is defined as the time from oxygen introduction ( $T_0$ ) to this onset time.

$$OIT_2(\text{tangent}) = T_2 - T_0 \quad (5)$$

17.9 Report

17.9.1 Report the following information:

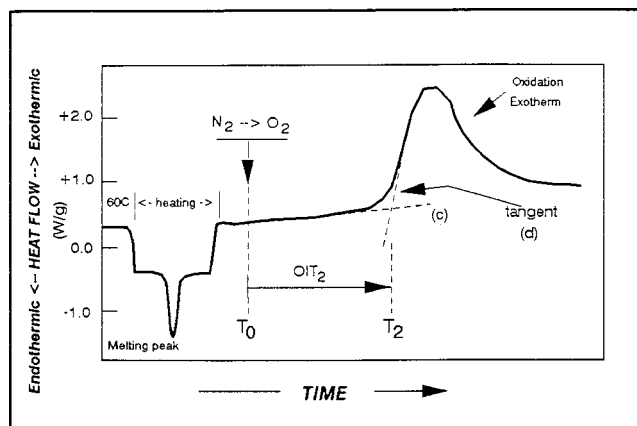

FIG. 4 OIT<sub>2</sub> Tangent Method

TABLE 2 Summary of Precision Data

Sample (Five specimens were run for each sample)	Mean OIT Value (min)	Repeatability Within Laboratory ( $\sigma_1$ )		Reproducibility Laboratory-to-Laboratory ( $\sigma_R$ )	
		(min)	(%)	(min)	(%)
HDPE Insulation (stripped from wire)					
OIT <sub>1</sub>	121.6	4.5	3.7	7.3	6.0
OIT <sub>2</sub>	126.4	2.8	2.2	7.2	5.7
HDPE Insulation (with copper wire)					
OIT <sub>1</sub>	62.6	6.2	10.0	10.0	16.0
OIT <sub>2</sub>	69.5	3.6	5.2	8.6	12.3

17.9.1.1 Melting temperatures (°C) for indium and tin together with the date of the last determination,

17.9.1.2 Heats of fusion (J/g) for indium and tin together with the date of the last determination,

17.9.1.3 Gas flow rate (mL/min),

17.9.1.4 Parameters for each specimen (stripped insulation, insulated wire, specimen mass, etc.),

17.9.1.5 Specimen temperature 5 min after gas switch to oxygen ( $T_0 + 5$  min), and

17.9.1.6 OIT<sub>1</sub> (offset) or OIT<sub>2</sub> (tangent). (Unless otherwise specified by the user, the reported OIT shall be OIT<sub>2</sub>, tangent method.)

17.9.1.7 If multiple specimens are tested, report average OIT values and standard deviations.

17.10 Precision and Bias

17.10.1 Precision—The precision of this test method for measuring Oxidative Induction Time, using Type I and Type II samples, is illustrated in Table 2. These statistics were determined from round robin studies between thirteen laboratories using both heat-flux and power-compensated thermal analyzers. All data and reports of the task force that developed this method are on file at ASTM.<sup>10</sup>

NOTE 12—The task force summarized its finding in a paper by V. J. Kuck published in the *Proceedings of the 6th International Conference on*

<sup>10</sup> Available from ASTM Headquarters, 100 Barr Harbor Drive, West Conshohocken, PA 19428. Request RR: D09-1034.

*Plastics in Telecommunications* (Pub. Plastics & Rubber Institute, London, England), September, 1992.

17.10.2 *Bias*—The test for oxidative induction time has no bias since it is defined in terms of this method.

NOTE 13—This test method employs indium and tin as internal standards for calibration of temperature and caloric sensing, and requires strict control of the test conditions to increase precision and hopefully to reduce the bias in the OIT measurement. However, as is mentioned in 17.3 and in Appendix X1, materials which are in the polyolefin may decompose at the high temperatures used, causing a shift of the OIT from the value for the polyolefin. Such a shift is important in the use of this method for quality control of the polyolefin compound. It is important to recognize that the same shift is a bias when the test is used to measure the OIT of the polyolefin.

**18. Oxygen Induction Time (Cable Filling Compound Only)**

18.1 *Scope*—This method covers a procedure for determining, by thermal analysis, the oxidative induction time of filling compound removed from completed wire or cable.

NOTE 14—For additional information on wire and cable filling compounds, refer to Specifications D 4731 and D 4732.

18.2 *Apparatus, Reagents and Materials:*

18.2.1 This test is normally performed using commercial devices commonly referred to as Differential Scanning Calorimeters (DSC) or as Differential Thermal Analyzers (DTA).<sup>9</sup> Other apparatus may be used if it can be demonstrated to yield comparable results. The following reagents and materials are also required to perform this test:

18.2.1.1 Use commercial cylinder nitrogen for purging instrument cells.

18.2.1.2 Use oxygen in this method equal to or better than 99.6 % extra dry grade.

18.2.1.3 Small specimen pans are required to hold the specimens while in the instrument cells. Pans shall be aluminum.

18.2.1.4 Use No. 316 stainless steel screen (40 mesh) to cover specimens in the pans.

18.2.1.5 Pure metal standards such as indium, tin, lead, and zinc may be required for instrument calibration.

18.3 *Sample Preparation*—Select at random a short-length section, approximately 1 ft (300 mm) long, of completed wire or cable. Remove the core from the wire or cable section; this may be accomplished by pulling or pushing the core out without cutting the jacket. Remove the filling compound from the core and isolate it from the cable or wires so as not to contaminate the compound. Obtain all samples of filling compound by taking them from manufactured cable or wire rather than by obtaining them in an unprocessed condition.

18.4 *Instrument Preparation*—Clean the instrument cells after they have been standing overnight and between the testing of different material formulations. To clean the cells, bring them up to temperature and hold them at approximately 400°C for a period of 10 min in nitrogen.

18.5 *Instrument Calibration*—Adjust temperature scales according to instrument manual instructions until the determined melting point of pure indium metal is indicated as 156.6°C at a heating rate of 5°C/min.

NOTE 15—This note on calibration is written specifically for the instruments described in footnote 10. Other equipment may be equally suitable but may yield slightly different results when testing identical specimens. For the Perkin-Elmer DSC, run several pure metal standards (such as, indium, tin, lead, zinc) through their melting point at a heating rate of 5°C/min. Plot melting temperatures and interpolate to find the required set point. Repeat calibrations require only adjustments for the indium melt temperature.

For the DuPont DTA with a DSC Cell, set the instrument in the isothermal mode and calibrate the starting-temperature dial according to the instrument manual. Alternately, the dial may be set to a reading that results in a corrected thermocouple read-out of the required temperature.

18.6 *Preparation*—Place 3 to 5 mg of the filling material to be tested into an aluminum pan and cover this with a clean stainless steel screen. Crimp the pan to hold the screen in place.

18.7 Place the prepared specimen pan in the instrument cell. Flush the cell for 5 min using cylinder nitrogen at a flow rate of 200 ± 25 cm<sup>3</sup>/min. Following the nitrogen purge, increase the cell-specimen temperature (at a heating rate of 10°C/min) from the initial temperature to 190 ± 2°C. Once temperature equilibrium of 190°C has been reached (steady recorder signal), switch to oxygen flow at the same flow rate and simultaneously start the time base recording.

18.8 Record the start of the oxygen injection as time “zero.” Maintain the isothermal temperature of 190°C in the pure dry oxygen atmosphere until the oxidative reaction exotherm appears on the thermogram (see Fig. 5). When the test is completed, turn off the recorder, switch the gas back to nitrogen, and allow the cell temperature of the instrument to cool to ambient temperature. Remove and discard the pan and specimen.

18.9 On the recorder chart, draw an extension to the recorded base line beyond the oxidative reactive exotherm. Extrapolate the slope of the oxidative reactive exotherm to intercept the extended base line. The oxidative induction time (OIT) is measured to within ±1 min from zero time to the intercept point.

18.10 *Precision and Bias*—This test method is based on the exotherm obtained when the filling compound degrades. As such, precision of the test method is strongly dependent on the extent to which the filling compound under test is degraded. Since no calculation of OIT is possible, a comparison between the measured and the true values cannot be achieved.

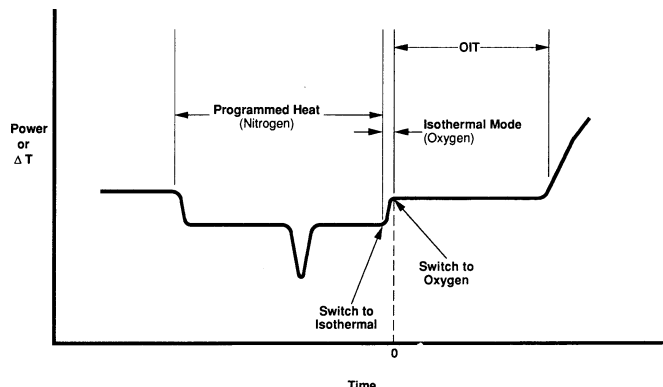

FIG. 5 Evaluation of Oxidative Induction Time (OIT) from Recorded-Time-Base Thermogram

## 19. Insulation Adhesion

19.1 Test specimens of finished insulated conductor for insulation adhesion. Prepare specimens by first trimming insulated wire specimens to 5 in. (130 mm) in length. Remove the insulation (by progressively removing short sections) from one end of the wire until only a 1-in. (25-mm) length of undisturbed insulation remains at the other end of the specimen. **Caution:** Exercise great care in this step to avoid nicking the conductor while removing the insulation. Pass the bared conductor through a die plate or orifice having an aperture measuring 0.003 to 0.005 in. (0.07 to 0.13 mm) larger than the conductor until the shoulder of insulation rests on the die plate. Apply tension between the conductor and the die plate and measure the force required to strip the remaining insulation from the wire. Compare results with the requirements specified in the product specification. The speed of the moving head of the tensile testing machine shall be as prescribed by the product specification.

19.2 *Precision and Bias*—The precision of this test has not been determined. No statement can be made about the bias of this test for insulation adhesion since the result merely states whether there is conformance to the criteria for success specified in the product specification.

## 20. Insulation Compression

20.1 Condition a 6-in. (150-mm) specimen of insulated conductor for a minimum of 1 h under standard atmospheric conditions in accordance with Specification E 171. After conditioning, place the specimen between the faces of two steel plates, measuring 2 in. (50 mm) in length or diameter, mounted in such a manner that the faces remain parallel during the test. Apply pressure to produce the rate of approach specified in the product specification. Failure is defined as the completion of a low-voltage (60 V dc or less) electric circuit between the tested conductor and either steel plate. A bell, buzzer, lamp or other signal device shall be activated to indicate completion of the circuit.

20.2 *Precision and Bias*—The precision of this method has not been determined. No statement can be made about the bias of this test for insulation compression since the result merely states whether there is conformance to the criteria for success specified in the product specification.

## 21. Environmental Stress Crack (Polyolefin Jackets Only)

21.1 Perform tests on specimens die cut in the transverse direction from cable jackets having an outside diameter of 1.125 in. (30 mm) and larger. Prepare these specimens and subject them to an environmental stress cracking test as specified in Test Method D 1693 except that the conditioning requirement is waived, the depth of the controlled imperfection shall be proportional to the jacket thickness, and the stress cracking reagent shall be a 10 % solution (by volume) of Igepal® CO-630 (Antarox CO-630) surfactant.<sup>11</sup>

<sup>11</sup> Igepal is the registered trade name of GAF Corp, and is available from Dyestuff and Chemical Division, 140 W. 51st Street, New York, NY 10070. There is no known equivalent material.

21.2 *Precision and Bias*—The precision of this test has not been determined. No statement can be made about the bias of this test for environmental stress crack (jacket only) since the result merely states whether there is conformance to the criteria for success specified in the product specification.

## 22. Heat Distortion (Jackets Only)

22.1 This test is for polyvinyl chloride (PVC) jacket material only.

22.2 Prepare a sample approximately 8 in. (200 mm) long to have a thickness of  $0.050 \pm 0.010$  in. ( $1.27 \pm 0.25$  mm) and smooth surfaces. From this sample, prepare test specimens 1 in. (25.4 mm) long and  $0.56 \pm 0.063$  in. ( $14.3 \pm 1.6$  mm) wide. Where the diameter of the cable does not permit the preparation of a specimen 0.56 in. (14.3 mm) wide, a molded sheet of the same compound may be used.

22.3 Measure the thickness of the specimen,  $T_1$ , using a Randall and Stickney gage, or the equivalent, having a 0.375-in. (9.5 mm) foot with no loading other than the 85 grams-force of the gage.

22.4 In 3 h, complete the following procedure: Place a Randall and Stickney gage, or the equivalent, with a load of 2000 g on the foot in an oven that is preheated to a specified temperature. At the end of 1 h, place the test specimen in the oven, and hold both the gage and the test specimen in the oven for 1 h. At the end of this 1-h period, place the specimen directly under the foot of the gage and allow it to remain in the oven under load for 1 h at the specified temperature. At the end of this period, read the dial for  $T_2$ .

22.5 Calculate the distortion as follows:

$$\% \text{ Distortion} = \frac{T_1 - T_2}{T_1} \times 100 \quad (6)$$

22.6 *Precision and Bias*—The precision of this test has not been determined. No statement can be made about the bias of this test for heat distortion (jackets only) since the result merely states whether there is conformance to the criteria for success specified in the product specification.

## 23. Heat Shock (Jackets Only)

23.1 This test is for PVC jacket material only.

23.2 Tightly wind specimens of PVC jacketed cable around a mandrel for one-half turn (180° bend). The mandrel shall have a diameter as follows:

Outside Diameter of Cable		Mandrel Diameter as Multiple of Cable OD
in.	(mm)	
0–0.750	(0–19.05)	3X
0.751–1.500	(19.06–38.10)	8X
1.501 and larger	(38.11 and larger)	12X

23.3 Hold the specimens firmly in place, subject to a temperature of  $121 \pm 1^\circ\text{C}$  for 1 h, and then visually examine the inside and outside of the bend for cracks (normal vision or corrected-to-normal vision without magnification).

23.4 *Precision and Bias*—The precision of this test has not been determined. No statement can be made about the bias of this test for heat shock (jackets only) since the result merely states whether there is conformance to the criteria for success specified in the product specification.

## 24. Aging Test (Jackets Only)

24.1 This test is intended for PVC jacket material only.

24.2 Perform tests using Test Method D 638, Type IV die specimen shapes, die cut from the jackets. The minimum thickness of the specimen shall be 0.020 in. (0.51 mm).

24.3 Oven-age the specified number of specimens for the time period and at the temperature specified in the product specification. Test these specimens, as well as unaged specimens, in accordance with Test Method D 638 to determine tensile strength and elongation. The speed of testing shall be 20 in./min (500 mm/min).

24.4 Report test results as a percentage of unaged value.

24.5 *Precision and Bias*—The precision and bias of these methods of measuring tensile and elongation of jackets are as specified in Test Method D 638.

## 25. Oil Immersion Test (Jackets Only)

25.1 This test is for PVC jacket material only.

25.2 Perform tests using Test Method D 638, Type IV die specimen shapes, die cut from the jackets. The minimum thickness of the specimen shall be 0.030 in. (0.76 mm).

25.3 Unless otherwise specified in the product specification, immerse a specified number of specimens in ASTM No. 2 oil (described in Table 1 of Test Method D 471) for 4 h at  $70 \pm 1^\circ\text{C}$ . These specimens, as well as non-immersed specimens, shall then be tested, within 16 to 96 h after the oil immersion has been completed, in accordance with Test Method D 638 to determine tensile strength and elongation. The speed of testing shall be 20 in./min (500 mm/min).

25.4 Test results shall be reported as a percentage of non-immersed values.

25.5 *Precision and Bias*—The precision and bias of these methods of measuring tensile and elongation properties of jackets are as specified in Test Method D 638.

## PHYSICAL AND ENVIRONMENTAL METHODS FOR TESTING INSULATIONS AND JACKETS OF COMPLETED WIRE AND CABLE

### 26. Scope

26.1 Physical and environmental tests of completed wire and cable include but are not limited to determination of some or all of the properties covered in Sections 28-42.

### 27. Significance and Use

27.1 Physical and environmental tests for completed wire and cable, properly interpreted, provide information with regard to the physical properties of the insulation or jacket in the finished product configuration. The physical test values give an approximation of how the finished product will physically perform during its service life. Physical tests may provide data for research and development, engineering design, quality control, and acceptance or rejection under specifications.

### 28. Jacket Peel or Pull

28.1 This test is for PVC jackets only. Conduct the test under standard atmospheric conditions in accordance with Specification E 171.

28.2 Suspend a 4-ft (1.2-m) specimen of cable vertically so the cable is accessible for stripping. Butt-trim the upper end of the cable, slit the jacket from top to bottom, and roll the upper edge down approximately 2 in. (50 mm). Attach a specified weight at the upper end of the jacket and opposite the slit.

28.3 Observe to verify that the adhesion is such that 3 ft of jacket falls off in not more than the specified time with no external force applied other than the attached weight.

28.4 *Precision and Bias*—The precision of this test has not been determined. No statement can be made about the bias of this test for jacket peel or pull since the result merely states whether there is conformance to the criteria for success specified in the product specification.

### 29. Jacket Bonding Test

29.1 This test is for wire or cable jackets that are bonded to an underlying plastic coated shield or armor. Test the degree of bond as described in 29.2 through 29.5. Conduct the test under standard atmospheric conditions in accordance with Specification E 171.

29.2 Remove a section of the sheath by slitting the jacket longitudinally along the line of the shield or armor overlap. Ring the cable circumferentially with a knife, and flex the wire or cable at the cut point (this will normally be sufficient to break the shield or armor at the ring). The sheath section removed must be long enough to permit performance of the balance of the test.

29.3 Open the sheath specimen and flatten it. Cut specimen strips (using shears or dies) in the circumferential direction. Cut three strips with each strip measuring 0.5 in. (13 mm) in width.

29.4 For each specimen, separate the shield or armor from the jacket at the overlap end. Separation should be only of a length sufficient to permit forming a tab of each sheath component. Fit these tabs into the upper and lower jaws of a suitable tensile testing machine.

29.5 Unless otherwise specified, the speed of the tensile testing machine jaw separation and the recorder chart speed shall be 10 to 12 in./min (250 to 300 mm/min). Operate the tensile machine while holding the specimen at  $90^\circ$  to the angle of pull and while recording the minimum force required to separate the shield or armor from the jacket. Repeat for each test strip specimen. Compare observed bonding with the product specification requirements. A required uniform bonding is normally defined in terms of a specified minimum bond strength (in lbf/in. or N/m of width) over a specified minimum percentage of the wire or cable circumference.

29.6 *Precision and Bias*—The precision of this test has not been determined. No statement can be made about the bias of this test for jacket bonding since the result merely states whether there is conformance to the criteria for success specified in the product specification.

### 30. Jacket Slip Strength Test

30.1 This test is applied as a qualification test for wire or cable structures where flooding materials are applied to fill air spaces within the sheath.

30.2 Prepare the test specimen as follows:

30.2.1 Cut a wire or cable sample measuring 2 ft (600 mm) in length.

30.2.2 Remove 4 in. (100 mm) of only the jacket from one end (End 1) of the sample length, being careful to avoid cuts or distortions in the underlying shield or armor, or both. Remove 8 in. (200 mm) of only the jacket from the other end of the sample (End 2), observing the same precautions as noted above. The second cut should be made in a plane as nearly perpendicular to the wire or cable axis as possible. After this preparation, an undisturbed section of jacket should cover the shield or armor, or both, for  $12.0 \pm 2.5$  in. ( $300 \pm 60$  mm).

30.3 Prepare a test fixture consisting of a fixed firm plate (for example, 0.25-in. (6-mm) steel plate) with a hole drilled in it of such a size that the shielded or armored, or shielded and armored specimen section will pass freely through the hole but the jacket shoulder will rest on the plate around the perimeter of the hole.

30.4 Mount the test plate in a tensile tester in such a manner that the plate can be held or pulled while in a plane at right angles to the pull. The tensile apparatus must be such that the longer section (End 2) of the non-jacketed specimen can be inserted through the hole in the plate and grasped with a suitable grip so that the gripping edge is no closer than 4 in. (100 mm) from the test plate.

30.4.1 For specimens to be tested while in the oven, insert End 2 through the test plate and grip it.

30.5 Condition the specimen (discrete or installed in the tensile tester, as appropriate) in the oven at a specified temperature for a prescribed period of time (unless otherwise specified, condition for 1 h at  $50 \pm 2^\circ\text{C}$ ).

30.5.1 For installed specimens to be tested in the oven, test promptly in accordance with 30.6.

30.5.2 For discrete specimens (not mounted in the tester), remove the specimen from the oven at the end of the conditioning period, insert End 2 through the test plate installed in 30.4, and test immediately.

NOTE 16—The specimen will cool very rapidly, so be careful to keep the specimen hot and to complete the test as quickly as possible.

30.6 Pull the shielded or armored or shielded and armored wire or cable core through the test plate at a test speed of 2-in./min (50-mm/min) until the jacket has slipped over a 2-in. (50-mm) distance. Observe and record the highest load attained.

30.7 *Precision and Bias*—The precision of this test has not been determined. No statement can be made about the bias of this test for jacket slip strength since the result merely states whether there is conformance to the criteria for success specified in the product specification.

### 31. Sheath Adherence Test

31.1 This test may be applied as a qualification test for wire and cable structures where filling or flooding materials are applied to fill the air spaces within the sheath and where bonding is not required between the shield and the outer jacket.

31.2 Prepare the test specimen as follows:

31.2.1 Cut a wire or cable sample measuring 18 in. (460 mm) in length.

31.2.2 Remove 3 in. (80 mm) of jacket from one end (End 1) of the sample length, being careful to avoid cuts or distortions in the underlying shield or armor, or both.

31.2.3 Measure and record the diameter over the exposed shield or armor.

31.2.4 Clamp a gripping fixture around the outer metal shield or armor (Fig. 6).

31.2.5 Make two longitudinal cuts in the jacket at the other end of the sample (End 2), each cut to be 3 in. (80 mm) in length and separated  $180^\circ$  (circumferentially) from the other cut. (Exception: On large cables, it may be necessary to make more than two cuts equally spaced in order to bend the jacket segments back.) Fold back the jacket segments and cut out and remove the underlying shield or armor, or both, and the cable core structure. Leave the remaining  $12.0 \pm 0.5$  in. ( $305 \pm 13$  mm) long middle section of the specimen undisturbed.

31.2.6 Insert a knurled or threaded mandrel between the two unsupported jacket segments created in 31.2.5 (Fig. 3), and clamp the jacket segments to hold them firmly against the mandrel. Use a mandrel having approximately the same diameter as the cable core.

31.3 Condition the prepared specimen for a minimum of 1 h in an oven at a temperature as specified in the product specification. For a tensile tester integrated with an oven, mount the specimen in the tensile tester at the start of conditioning; if a discrete oven is used, mount the specimen in the tensile tester immediately after conditioning.

31.4 As soon as temperature conditioning is concluded, and with the specimen mounted in the tester, operate the tensile

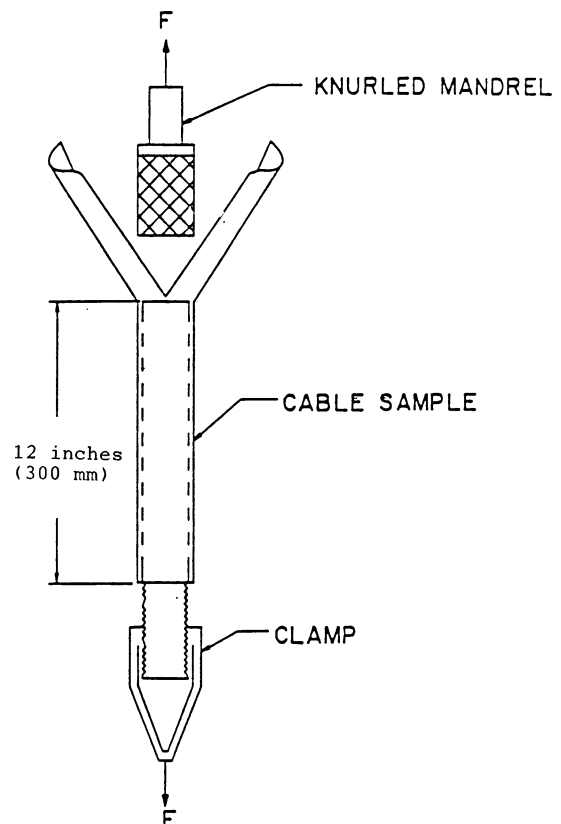

FIG. 6 Sheath Adherence Specimen Preparation

tester at a jaw separation speed as specified in the product specification, but not exceeding 10 in. (250 mm) per min. Observe the specimen and determine and record the force required to initiate a slippage between the jacket and the underlying shield or armor. Use of a stress-strain recorder is recommended. Unless otherwise specified, for specimens which must be tested outside the oven, complete the test within 30 s of removal from the oven.

31.5 Using the diameter measured in 31.2.3, calculate the circumference around the shield or armor. Divide the slippage-initiation force measured in 31.4 by the shield or armor circumference to determine the force in lb/in. (N/mm) of circumference.

31.6 *Precision and Bias*—The precision of this test has not been determined. No statement can be made about the bias of this method for sheath adherence test since a standard material is not available.

**32. Jacket Notch Test**

32.1 This test is intended primarily for the evaluation of jackets applied over steel-shielded or steel-armored cable in which the steel is applied longitudinally. This test measures the potential for jacket failure due to notch formation from the steel shield. The test is performed on a sample of outer jacket removed from completed cable.

32.2 Prepare the test specimen as follows:

32.2.1 From the completed cable, cut a ring sample length  $1.125 \pm 0.125$  in. ( $28.6 \pm 3.2$  mm) long. Remove the cable core structure and aluminum shield (if present) from the sample, leaving the circumferential sheath ring (jacket and steel) intact.

32.2.2 Locate the area on the ring of sheath where the steel is overlapped. Cut the sheath sample longitudinally at a point opposite ( $180^\circ$  away from) the steel overlap to form a broken ring.

32.2.3 Remove the jacket from the steel of the sheath. If the steel is bonded to the jacket, remove the jacket from the steel by one of the following methods:

32.2.3.1 *Heat method*—Using flat-jawed pliers (for example, modified gas pliers) or a vise, firmly hold the steel overlap area of the sheath. Carefully separate the two sides of sheath (at the longitudinal cut), spreading the sides apart for a distance of approximately one cable diameter, while exercising care not to bend or damage the steel overlap area. Using a heat gun, direct hot air at the steel side of the specimen while peeling the steel from the jacket. If this procedure is properly followed, the jacket sample will be no more than warm to the touch after the steel is removed.

32.2.3.2 *Solvent method*—Hold the split ring of sheath parallel to the work bench and so that the steel overlap is on the bottom of the ring. Apply a thin layer of 1,1,1-Trichloroethane solvent only (this is the only solvent that is known to produce acceptable results; use of other solvents is likely to bias the test results) on the overlap seam and allow the specimen to rest until the edge of the steel can be bent up using needle nose pliers (approximately 5 to 10 s is sufficient time). Apply additional solvent to coat the bottom of the trough formed by bending up the steel overlap. Again, allow the sample to rest for a few seconds and then use the pliers to peel the steel

further away from the jacket; stop the peeling effort when the coating on the steel begins to resist further separation. Reapply solvent and repeat the process until the steel is completely removed. Throughout the process, allow the solvent to dissolve the bond and do not force the removal of any portion of the steel.

32.2.4 After the steel has been removed, allow the jacket specimen to stabilize at room temperature. Gently wipe away any residual solvent, if the solvent method was used.

32.2.5 Prepare Type IV tension test specimens (dumbbell shaped) per Test Method D 638 by die-cutting from jacket specimens, taking care to assure that the notched area in the jacket specimen (from the steel overlap) is centered in and bisects the tensile bar of the die-cut specimen. Mark 1 in. (25.4 mm) gage marks on the specimen, centered on the notch in the specimen.

32.3 Clamp the specimen in the jaws of a tensile testing machine with the notch in the specimen centered between the jaws (Fig. 7). Use of self-aligning grips is preferred. Adjust jaw separation based upon the original cable diameter, as follows:

Cable Diameter	Fig. 4 Dimension "A" Jaw Separation
<1.25 in. (32 mm)	1.5 in. (38 mm)
$\geq 1.25$ in. (32 mm)	2.5 in. (64 mm)

32.4 Operate the tensile tester at a jaw separation speed of not less than 2 in. (51 mm)/min and not greater than 20 in. (508 mm)/min. Observe the specimen and determine and record the minimum elongation (gage length increase) that occurs before the specimen starts to tear or break. Compare results with the requirements of the product specification.

NOTE 17—If the sample slips in, or breaks at, the jaws before the product specification requirement is met, the test is invalid and shall be repeated on a new sample; however, if the jacket begins to neck outside the jaws, it is acceptable for the necking to progress between the jaws as the test proceeds.

32.5 If the specimen fails the test, obtain two additional adjacent sheath samples and prepare and test each specimen as

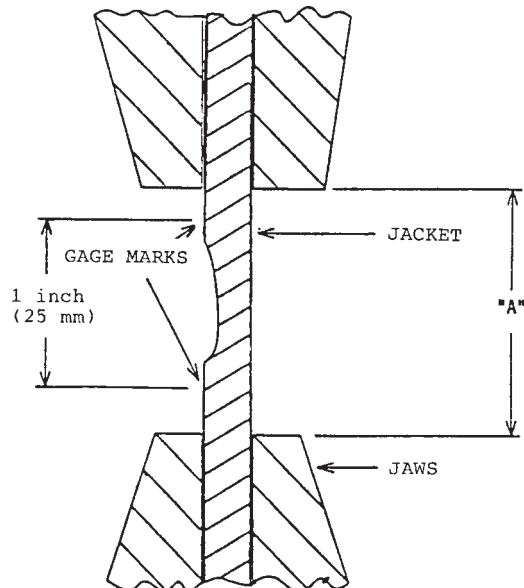

FIG. 7 Specimen Preparation for Notch Test

described above; unless otherwise specified, the cable fails the test unless both re-test specimens meet the requirements.

32.6 *Precision and Bias*—The precision of this test has not been determined. No statement can be made about the bias of this method for jacket notch test since a standard material is not available.

### 33. Cable Impact Test

33.1 Secure a specimen of jacketed cable approximately 15 in. (380 mm) in length across the bottom of a tube (or equivalent guiding device) measuring 1.25 in. (32 mm) in inside diameter. Place the specimen and tube assembly, with the tube in a vertical position and the specimen resting lengthwise in the direction of the grain, on a firm wooden surface (a piece of standard 2 by 4-in. (50 by 100-mm) minimum lumber, red or white oak, clear grade, or equivalent) in a cold chamber.

33.2 Maintain the setup and chamber at the specified temperature for a minimum period of 4 h.

33.3 At the end of the conditioning period and while still in the chamber, release a weight at the top of the tube, allowing it to strike the specimen. The weight used shall be in the form of a cylinder measuring 1.0 in. (25.4 mm) in diameter with a flat striking surface (edges of the face may be slightly rounded if desired). The dropping distance (measured between the weight face and the top of the specimen) and the weight shall be such that the specified impact force is delivered to the jacketed specimen. Take care to ensure that the specimen is struck squarely.

33.4 After impact, remove the specimen and apparatus from the cold chamber and allow them to warm to room temperature for examination.

33.5 Remove the jacket and visually examine it (normal vision or corrected-to-normal vision without magnification), for the presence of cracks on either the inner or outer surface of the jacket or in the underlying conductor insulation.

33.6 *Precision and Bias*—The precision of this test has not been determined. No statement can be made about the bias of this test for cable impact test since the result merely states whether there is conformance to the criteria for success specified in the product specification.

### 34. Wire and Cable Bending Test

34.1 Cut a suitable length of wire or cable from a finished length. Make the cut specimen length long enough to allow the required bending to be performed comfortably. Remove the web and messenger of self supporting cable prior to conditioning and testing.

34.2 The test may be performed on specimens at room temperature or after cold conditioning as required by the detailed specification.

34.2.1 Stabilize room temperature specimens under standard atmospheric conditions in accordance with Specification E 171.

34.2.2 For specimens to be bent while they are cold, condition specimens at the specified temperature for the specified period to time. If not specified, condition at  $-20 \pm 2^\circ\text{C}$  for a minimum period of 4 h.

34.3 After temperature stabilization is completed, bend the specimen in a  $180^\circ$  arc around the specified mandrel. Upon completion of the first bend, straighten the specimen, rotate it  $180^\circ$  and repeat the  $180^\circ$  bend (that is, with the second bend in the opposite direction from the first bend). Upon completion of the second bend, straighten the specimen, rotate it  $90^\circ$  and again bend it in a  $180^\circ$  arc. Upon completion of the third bend, straighten the specimen, rotate it  $180^\circ$  and then bend it for the fourth time (that is, with the fourth bend in a direction opposite to the third bend). Straighten the specimen for the final time.

34.3.1 The rate of bending shall be such that the entire cycle of four bends is completed within the maximum time allowed by the product specification.

34.3.2 Use mandrel diameters as follows:

Wire or Cable Classification	Mandrel Diameter as a Multiple of Specimen Diameter
Non-Gopher Resistant	15×
Gopher Resistant	20×

34.3.3 When shielded or armored or shielded and armored wire or cable is subject to this test, make the initial bend with the outer shield or armor overlap on the outside of the bend.

34.3.4 For cold-conditioned specimens, conduct the bending while the specimen is in the cold chamber; alternately, bending may be conducted immediately upon removal from the cold chamber, provided that the mandrel is a thermal non-conductor such as wood.

34.4 Upon completion of bending, visually inspect specimens (normal vision or corrected-to-normal vision without magnification) for damage in the bent area for evidence of fracture in the inner or outer surface of the jacket, in the internal screen, if present, in the shield or armor, or both, or in the insulation.

34.4.1 For cold-conditioned specimens, allow the specimen to return to room temperature before inspection.

34.5 *Precision and Bias*—The precision of this test has not been determined. No statement can be made about the bias of this test for wire and cable bending since the result merely states whether there is conformance to the criteria for success specified in the product specification.

### 35. Wire and Cable Wrap Test

35.1 Cut a suitable length of wire or cable from a finished length of shielded or unshielded wire or cable with 25 or fewer pairs. Make the specimen length long enough to allow the required bending to be performed comfortably.

35.2 Condition the wire or cable specimen at  $-20 \pm 2^\circ\text{C}$  ( $-4 \pm 4^\circ\text{F}$ ) for 4 h, unless otherwise specified in the detailed specification. While still in the cold chamber and at the conditioning temperature, wrap the specimen around a cylindrical mandrel at least three times ( $1080^\circ$ ) in less than 30 s.

35.3 Unless otherwise specified in the detailed specification, the mandrel diameter shall be equal to 8 times the wire or cable diameter, for wire or cable not containing a shield; 12 times the wire or cable diameter for wire or cable containing a thin laminated flat shield (metal less than 5 mils); and 15 times the wire or cable diameter for wire or cable containing a corrugated shield.

35.4 Alternatively, the test specimen may be removed from the cold chamber after conditioning and wrapped around the mandrel in less than 30 s after removal. If the mandrel is metal, it shall be conditioned at the same temperature as the specimens.

35.5 After removal from the cold chamber and mandrel, allow the specimens to return to room temperature and straighten. Visually inspect the bent area (normal vision or corrected-to-normal vision without magnification) of the specimens for evidence of fracture of the jacket. Carefully disassemble the wire or cable and inspect insulation and shield (when present) for evidence of fracture.

35.6 Precision and Bias:

35.6.1 Precision—This test method has been in use for many years, but no information has been presented to ASTM upon which to base a statement on precision.

35.6.2 Bias—No statement can be made about the bias of this test for wire and cable wrap since the result merely states whether there is conformance to the criteria for success specified in the product specification.

36. Corrugation Extensibility Test

36.1 This test is intended primarily for the evaluation of corrugated aluminum or steel shields or armors in completed cable. The test is limited to metal tape materials listed below with tension loads in lb/in. (N/mm) width of specimen as specified.

Tape Metal	Tensile Load Limits per Width of Specimen lb/in.	(N/mm)
Aluminum	52 to 55	(9.1 to 9.6)
Steel	176 to 180	(30.8 to 31.5)

36.2 Prepare the test specimen as follows:

36.2.1 From the completed cable, cut a sample length measuring approximately 5 in. (127 mm) long. Remove the cable core structure from the sample, leaving the circumferential sheath (jacket and shield or armor or both) intact.

36.2.2 Locate the area on the ring of sheath where the corrugated metal is overlapped. At some point away from this overlap, cut the sheath sample longitudinally (perpendicular to the metal corrugations) to obtain a specimen strip measuring 0.25 to 0.50 in. (6.4 to 12.7 mm) wide.

36.2.3 Mark the metal of the specimen strip with the gage length. The minimum gage length shall be 1.0 in. (25 mm), but longer gage lengths may be used. Additional length may be provided as required for clamping in the jaws of the tensile testing machine.

36.2.4 Remove the jacket material from the metal of the specimen sheath strip. If the metal is bonded to the jacket, remove the jacket from the metal by following a modified heat method (32.2.3.1) or a modified solvent method (32.2.3.2) or any other suitable method that will permit removal of the jacket without deforming the metal specimen.

36.3 Clamp the specimen in the jaws of a tensile testing machine with the marked gage length on the specimen centered between the jaws. Use of self-aligning grips is preferred.

36.4 Operate the tensile tester at a jaw separation speed such that the strain rate does not exceed 1.0 in. (25 mm)/min/in. (25 mm) of gage length, with the pulling direction perpendicular to

the crests of the metal corrugations. Observe the specimen. Elongate the specimen within the load range specified in 36.1 until:

$$P = \frac{(L_2 - L_1)}{L_1} \times 100 \tag{7}$$

where:

- P = Minimum extensibility, %,
- L<sub>1</sub> = Initial gage length in in. (mm), and
- L<sub>2</sub> = Final gage length in in. (mm).

The cable fails if the specimen breaks before the minimum extensibility limit is reached; however, the test need not proceed to the point where the specimen breaks, as long as the specified minimum extensibility is met. Determine gage lengths L<sub>1</sub> and L<sub>2</sub> from measurements made directly on the specimen. If it is necessary to stop the machine and reclamp the specimen, take care to ensure that the indicated gage length remains entirely outside of the clamped portion of the specimen throughout the test. Fig. 8 (for aluminum) and Fig. 9 (for steel) illustrate example percent extensibility limits that might be specified by product specifications for a range of cable diameters as measured under the metallic covering.

36.5 If the specimen fails, obtain two additional adjacent sheath samples and prepare and test each specimen as described above; unless otherwise specified, the cable fails test unless both re-test specimens meet the minimum extensibility requirements.

36.6 Precision and Bias—The precision of this test has not been determined. No statement can be made about the bias of this method for corrugation extensibility test since a standard material is not available.

37. Wire Breaking Strength

37.1 This test is used for testing telecommunications wires (see 3.1.11). Conduct the test under standard atmospheric conditions in accordance with Specification E 171. Cut a suitable length (a 3-ft (1-m) specimen is typical) of completed

EXT ≥ 2%	FOR D < 0.6 inch (15 mm)
EXT ≥ (6.10 × D) - 1.66 [EXT ≥ (0.24 × D) - 1.66]	FOR 0.6 ≤ D < 2.73 inches FOR 15 ≤ D < 69 mm]
EXT ≥ 15%	FOR D ≥ 2.73 inches (69 mm)

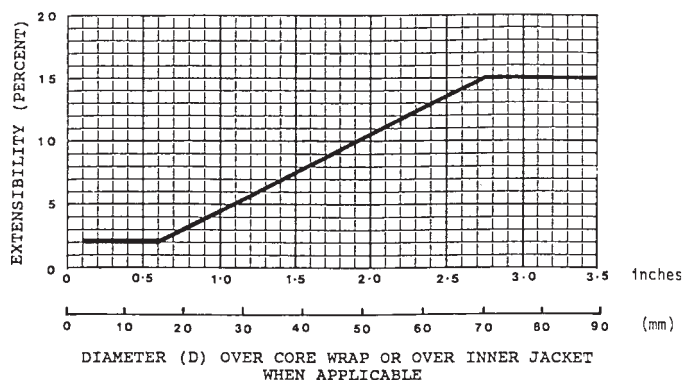

FIG. 8 Example Minimum Extensibility (EXT) Chart for Aluminum



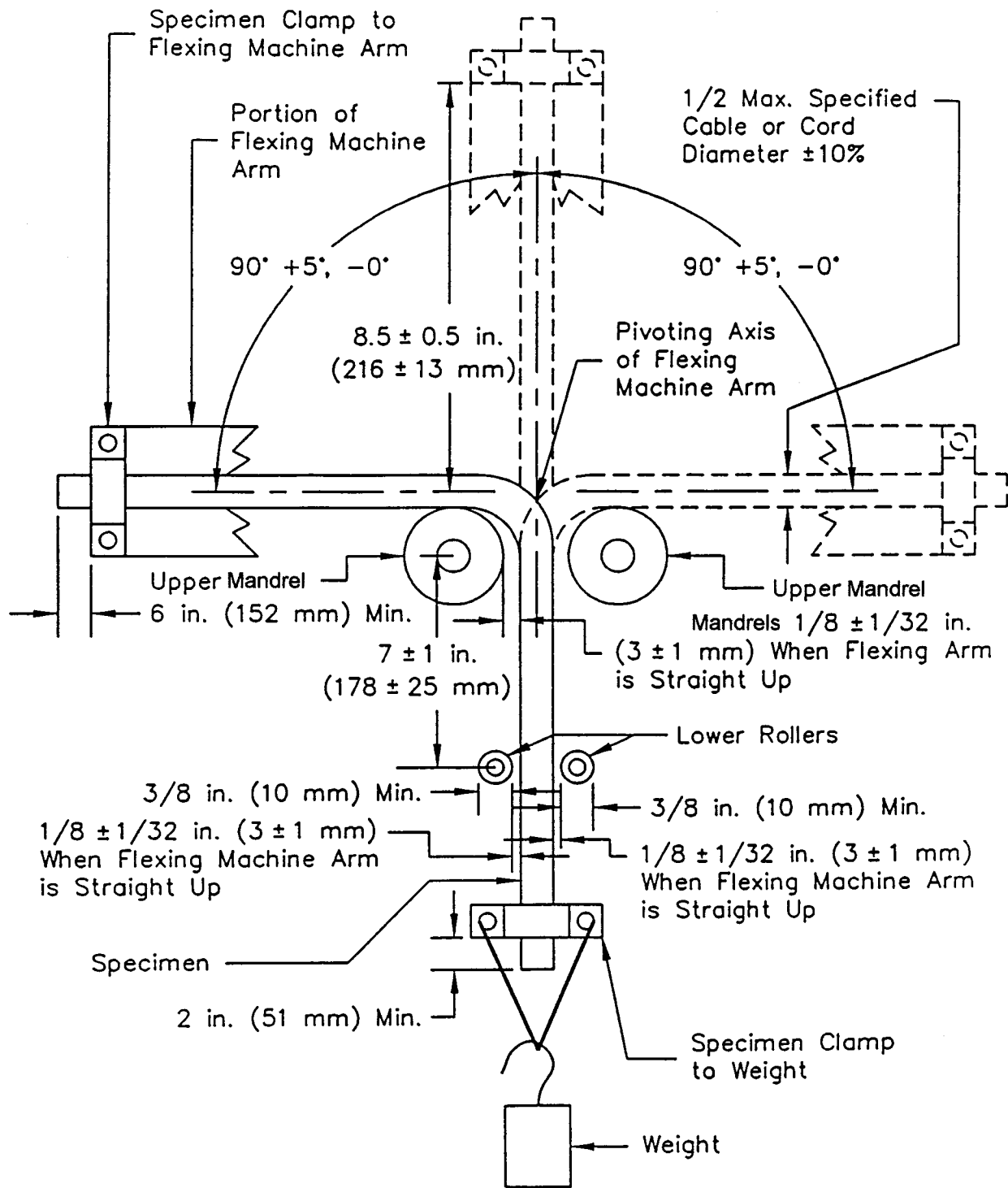

FIG. 10 Cable Flex Test Configuration and Apparatus

weak sections. Air core wire or cable may be ordered for shipment under pressure and must then be pressurized and tested as required.

40.3 Test the finished wire or cable (equipped with end caps or pulling eyes or both) for pressure integrity, using end seals equipped with a device to apply and maintain pressure (for example, a tire pressure valve). For the pressurizing gas, use dry air or nitrogen having a relative humidity not greater than 2% at 21°C.

40.4 Apply dry air or nitrogen under pressure to obtain the stabilized pressure level prescribed by the product specification, normally 9 to 18 psig (62 to 124 kPa). (Due to the pneumatic resistance of telecommunications wire or cable, especially small pair count or small gage wire or cable, care must be exercised to prevent over pressurizing.) Monitor the pressure at both ends of the wire or cable on a regular basis.

40.5 When the desired pressure is indicated at both ends of the wire or cable, record this as the initial pressure level.

Maintain the prescribed pressure for the specified period of time (4-h minimum). Remeasure the pressure at both ends of the wire or cable at the end of the holding time and calculate the amount of pressure decrease. The maximum allowable pressure drop shall be 1.0 psig. (6.9 kPa) after correcting for temperature variation.

40.6 *Precision and Bias*—The precision of this test has not been determined. No statement can be made about the bias of this test for pressure since the result merely states whether there is conformance to the criteria for success as specified in the product specification.

#### 41. Water Penetration Test (Filled Core Wire and Cable Only)

41.1 From a length of finished wire or cable, cut a 3-ft (1-m) specimen length. Stabilize the specimen and conduct the subsequent test under standard atmospheric conditions in accordance with Specification E 171.

41.2 The cable end that will not be subjected to water pressure shall remain unsealed. If necessary, adjust this end to ensure that it is free of any distortion or compression that might restrict water flow.

41.3 At the cable end to which water pressure is to be applied, prepare the sheath by cutting back approximately 0.5 in. (13 mm) of each sheath interface. Loosen the core at this end to avoid any restriction to water entry caused by packing or by compression resulting from the original cutting of the specimen.

41.4 Place a watertight closure over the outer jacket of the prepared specimen end. This installed closure must be sufficiently tight to prohibit leaks between the jacket and the closure, but not so tight as to restrict the flow of water through pre-existing voids or through air spaces in the core or sheath. Place the specimen in a horizontal position with provision made to detect water flow from the unsealed end.

41.5 Fill the watertight closure with water to apply the required water pressure to the specimen; maintain pressure for the prescribed period of time. At the end of the test period, examine the test set-up for evidence of water leakage through any portion of the core, over or under the core wrap, or through any sheath interface.

41.6 An additional adjacent specimen from the same finished length may be tested to re-check apparent failures. Unless otherwise specified, a retest length of 10 ft (3 m) is allowed.

NOTE 18—Unless otherwise prohibited, another fluid other than water (for example, air) may be used in lieu of water, with appropriate measures taken to detect fluid flow.

NOTE 19—If desired for diagnostic purposes, a solution of Uranine in water may be used in lieu of plain tap water and an ultraviolet light can then be used to examine dissected specimens to determine flow paths, etc.

41.7 *Precision and Bias*—The precision of this test has not been determined. No statement can be made about the bias of this test for water penetration since the result merely states whether there is conformance to the criteria for success as specified in the product specification.

#### 42. Compound Flow Test (Filled Core Cable Only)

NOTE 20—For additional information on wire and cable filling compounds, refer to Specifications D 4731 and D 4732.

42.1 Cut samples as required from finished wire and cable.

42.2 Make specimens 1 ft (300 mm) in total length, prepared as follows:

42.2.1 Cut and remove 5 in. (130 mm) of jacketing material from one end of each specimen.

42.2.2 Cut and remove 3 in. (80 mm) of shielding or armoring, or both, and core wrap from the same end to expose the filled core.

42.2.3 Unless otherwise specified, the remaining cable jacket(s) and shield or armor or both (but not including the core wrap) may be longitudinally slit to relieve pressure created at elevated temperatures.

42.2.4 Flare the exposed core members slightly to provide reasonable separation of the pairs.

42.2.5 Loosely adhered globules of filling or flooding material may be removed from the flared cable end, but the individual wire or cable members must remain essentially coated by the filling or flooding material (that is, do not wipe clean).

42.3 Preheat the air oven to the prescribed temperature.

42.4 Suspend the specimens in the oven with the specimen axes essentially vertical and with the flared ends pointing downward. Position a glass dish (or other drip-catching medium) on a shelf or on the oven floor, directly under each specimen.

42.5 Stabilize the oven temperature and expose the specimens to the specified oven temperature for the specified period of time. If not specified, test the specimens for a minimum period of 24 h.

42.6 At the end of the test period, examine the glass dish (or other) for any evidence of flowing or dripping of compound from the core, from any core member, or from any sheath interface. When specified or required by the detailed product specification, weigh the drip-catching medium before and after the test and thereby determine and record the mass of any drippings.

42.7 *Precision and Bias*—The precision of this test has not been determined. No statement can be made about the bias of this test for compound flow since the result merely states whether there is conformance to the criteria for success as specified in the product specification.

#### 43. Report

43.1 If not otherwise specified, the test results of the wire or cable physical and environmental performance properties, with identifying units, shall be recorded on a report form that includes the following:

43.1.1 Identification of the wire or cable sampled and tested by pair count, gage, sheath type, reel number, length, air core, or filled core, and so forth,

43.1.2 Identification of the material sampled and tested by how it was used (insulation, jacket, and so forth) and by type (for example, polyethylene as specified in Specification D 1248),

43.1.3 Date of testing,

43.1.4 Location of testing laboratory and the person responsible for the testing,

43.1.5 Remarks indicating the method or procedure used and the deviation, if any, from the standard procedure,

43.1.6 Indication of the variance in test measurements such as high, low, standard deviation, etc., and

43.1.7 Minimum, maximum, and average values as applicable and any other information that is appropriate to the test being performed (for example, raw material baseline as specified in 12.1).

43.2 The test results shall be reported as calculated or observed values rounded to the nearest unit in the last right hand place of figures used in the wire or cable specification to express the limiting value. (See the rounding method of Practice E 29.)

## 44. Keywords

44.1 aging test; cable impact; cable torsion; cold bend; compound flow; corrugation extensibility; cross-sectional area; diameters; differential scanning calorimetry; eccentricity; environmental stress crack; heat distortion; insulation; insulation adhesion; insulation compression; insulation shrinkback; jacket bonding; jacket notch; jacket peel or pull; jacket shrinkback; jacket slip strength; melt flow; oil immersion; oxidative induction time; oxidative stability; polyolefins; pressure test; sheath adherence; telecommunications wire and cable; tensile and elongation; thermal analysis; thickness; water penetration; wire and cable bending; wire breaking

## APPENDIX

### (Nonmandatory Information)

#### X1. INFORMATION ON SECTION 17

##### X1.1 Scope

X1.1.1 This revised method was specifically written for polyolefin insulated wires used in telecommunication cables. However, with some minor adjustments in specimen preparation and test temperatures, the method could be used to measure the Oxidative Induction Time (OIT) values for a large range of materials.

##### X1.2 Summary of Test Method and Significance and Use

X1.2.1 Insulations may be tested on the copper wire or stripped from the wire. The OIT value of the insulated wire (insulation and copper) is usually 50 to 70 % less than the OIT value measured for the insulation alone. Better precision was obtained if the insulation was stripped from the copper wire.

X1.2.2 Test temperatures for polyolefin insulations are usually between 170 and 220°C, with 200°C being most popular. At higher temperatures, the major concern is thermal degradation of the stabilizers or the polyolefin, or both. The mechanism of such high temperature degradation may be unrelated to the thermo-oxidative process that occurs at normal use temperatures (for example, maximum field temperatures are 30 to 50°C). At lower test temperatures (160 to 180°C), OIT times may become too long for convenient measurement. In addition, the onset of the oxidation exotherm is not as easily defined as at higher test temperatures. The oxidation rate at the lower temperatures is slower and the rapid slope changes shown in Fig. 3 and Fig. 4 are not observed.

##### X1.3 Apparatus and Materials

X1.3.1 The task force's aim was to allow use of all commercially available calorimeters for the OIT measurement outlined in this method. Although some aspects of the method were easier with some instruments (for example, a computerized data system is much easier than a pen chart recorder for data analysis), it was the task force's aim to write an OIT

method that can be performed on all available calorimeters by competent laboratory personnel.

X1.3.2 Copper pans produced inconsistent results and concerns were raised about the oxidation state of the copper. The variations found between laboratories with slightly different cleaning/oxidation practices for copper pans were too large for easy resolution by simple changes in the written procedures. Therefore, do not use copper pans.

X1.3.3 Degreasing of pans increased the average OIT value by ~4 to 5 %.

##### X1.4 Instrument Calibration

X1.4.1 The heating rates used for calibrations with indium and tin standards were selected to be compatible with other OIT test methods.

X1.4.2 The calibration criteria listed in this method should be readily achieved with all the commercial calorimeters.

##### X1.5 Sample Selection

X1.5.1 The number of insulated wires selected from a completed cable and the number of repeat specimens from a particular insulated wire are dependent on the intended use of the OIT measurement. For example, a quality program in the cable manufacturer's plant will have different sampling requirements from an R&D study searching for a new and improved stabilizer package. These sampling decisions are left to the discretion of the user.

X1.5.2 Solvents are avoided in preparation of the insulation specimen since typical stabilizers are more soluble in organic solvents than in any polyolefins. Solvents may extract stabilizers and alter the OIT value of the material.

##### X1.6 Procedure

X1.6.1 The  $\pm 0.3^\circ\text{C}$  requirement was selected as easily attainable but stringent enough to reduce variability in OIT

measurement. At 200°C, an increase of 0.5°C would reduce the OIT value by 5 %.

*ASTM International takes no position respecting the validity of any patent rights asserted in connection with any item mentioned in this standard. Users of this standard are expressly advised that determination of the validity of any such patent rights, and the risk of infringement of such rights, are entirely their own responsibility.*

*This standard is subject to revision at any time by the responsible technical committee and must be reviewed every five years and if not revised, either reapproved or withdrawn. Your comments are invited either for revision of this standard or for additional standards and should be addressed to ASTM International Headquarters. Your comments will receive careful consideration at a meeting of the responsible technical committee, which you may attend. If you feel that your comments have not received a fair hearing you should make your views known to the ASTM Committee on Standards, at the address shown below.*

*This standard is copyrighted by ASTM International, 100 Barr Harbor Drive, PO Box C700, West Conshohocken, PA 19428-2959, United States. Individual reprints (single or multiple copies) of this standard may be obtained by contacting ASTM at the above address or at 610-832-9585 (phone), 610-832-9555 (fax), or [service@astm.org](mailto:service@astm.org) (e-mail); or through the ASTM website ([www.astm.org](http://www.astm.org)).*