



Standard Test Method for Bond Strength of Electrical Insulating Varnishes by the Twisted-Coil Test¹

This standard is issued under the fixed designation D 4882; the number immediately following the designation indicates the year of original adoption or, in the case of revision, the year of last revision. A number in parentheses indicates the year of last reapproval. A superscript epsilon (ϵ) indicates an editorial change since the last revision or reapproval.

1. Scope

1.1 This test method covers the determination of the bond strength of an electrical insulating varnish when applied to a twisted coil of film-insulated magnet wire. The use of a particular type of film-insulated wire will show the values for that combination of film coating and varnish.

1.2 *This standard does not purport to address all, if any, of the safety concerns, if any, associated with its use. It is the responsibility of the user of this standard to establish appropriate safety and health practices and determine the applicability of regulatory limitations prior to use.* A specific precautionary statement is given in Section 7.

1.3 The values stated in inch-pound units are the standard. The values given in parentheses are for information only.

NOTE 1—Although this standard and IEC 61033, Method C differ in approach or detail, data obtained using either are technically equivalent.

2. Referenced Documents

2.1 ASTM Standards:

D 115 Test Methods for Testing Solvent Containing Varnishes Used for Electrical Insulation²

D 2519 Test Method for Bond Strength of Electrical Insulating Varnishes by the Helical Coil Test³

D 6054 Practice for Conditioning Electrical Insulating Materials for Testing³

2.2 IEC Standard:

IEC 61033 Test Methods for the Determination of Bond Strength of Impregnating Agents to an Enamelled Wire Substrate⁴

3. Terminology

3.1 Definitions of Terms Specific to This Standard:

3.1.1 *bond strength, n*—a measure of the force required to separate surfaces which have been bonded together.

¹ This test method is under the jurisdiction of ASTM Committee D-9 on Electrical and Electronic Insulating Materials and is the direct responsibility of Subcommittee D09.01 on Electrical Insulating Varnishes, Powders, and Encapsulating Compounds.

Current edition approved Sept. 10, 1997. Published February 1998. Originally published as D 4882 – 88. Last previous edition D 4882 – 93.

² *Annual Book of ASTM Standards*, Vol 10.01.

³ *Annual Book of ASTM Standards*, Vol 10.02.

⁴ Available from American National Standards Institute, 11 W. 42nd St., 13th Floor, New York, NY 10036.

4. Summary of Test Method

4.1 Flexural strength tests are made on twisted coils to determine the force required to break the coils under specific conditions.

5. Significance and Use

5.1 Values obtained by flexural test can provide information with regard to the bond strength of the particular varnish in combination with a particular type of magnet wire, when measured under conditions described in this test method.

6. Apparatus

6.1 Coil winder as shown in Fig. 1 and Fig. 2.

6.2 Coil Twister as shown in Fig. 3.

6.3 Test apparatus as described in Test Method D 2519.

7. Safety Precautions

7.1 Do not use varnish at temperatures above the flash point when inadequate ventilation and the possibility of flames or sparks exist. Store varnish in sealed containers. These precautions shall also apply to the handling of the required solvents and reagents.

8. Test Specimen Preparation

8.1 The test specimen is a wound coil made from film-insulated magnet wire, 28 AWG (0.320 mm). The coil shall be made by means of suitable winding equipment as shown in Fig. 1. To prevent opening of the coil after removal from the winding equipment, each end of the magnet wire, or short pieces of film-insulated wire, may be wrapped around the coil two or three times. For this purpose the winding equipment is provided with appropriate notches as shown in Fig. 2. For winding the coil the following dimensions apply:

Winding diameter	2.25 ± 0.05 in. (57 ± 1 mm)
Width of slot	.25 ± 0.05 in. (6 ± 1 mm)
Number of turns	100 (See Note 2)
Nominal wire diameter	28 AWG (0.320 mm)

NOTE 2—Instead of 100 turns of a single wire, 50 turns of two parallel wires may be used to provide a bifilar winding.

8.1.1 After the coil has been wound, remove it from the winding equipment and stretch into an oval shape. Twist the coil two full turns around its longitudinal axis by means of a twisting device as shown in Fig. 3 and Fig. 4. The twisted coil formed is about 0.28 in. (7 mm) in diameter and 3.25 to 3.5 in.

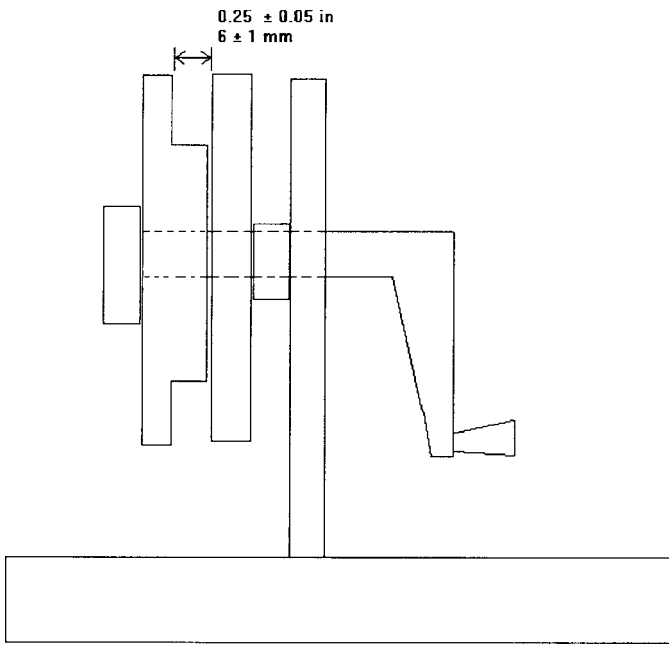

FIG. 1 Coil Winder

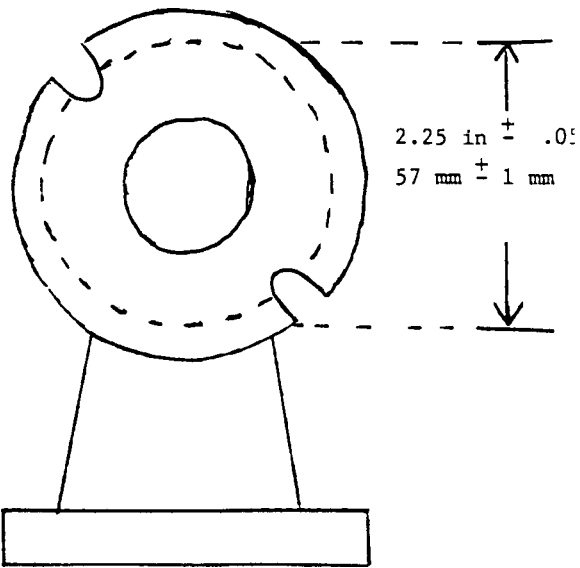

FIG. 2 Coil Winder, Front View

(85 to 90 mm) in length and serves as a substrate for the varnish.

8.2 The type of magnet wire should be mutually agreed upon between all involved parties.

8.3 Prepare six or more specimens for each condition to be investigated.

8.4 For solvent-containing varnishes, adjust the viscosity of the varnish by trial, to produce a dry film build of 0.0017 to 0.0021 in. (.043 to .053 mm) on a double-coated copper panel coated in accordance with Test Methods D 115.

8.5 For solventless varnishes no adjustment to the viscosity should be made.

8.6 Attach several twisted coils to a rack and immerse vertically in the varnish until bubbling stops. Withdraw them at 4 ± 0.2 in./min (100 ± 5 mm/min) and allow them to drain horizontally 10 to 12 min at standard laboratory atmosphere in accordance with Practice D 6054. For solvent-containing varnishes drain vertically 10 to 12 min at standard laboratory atmosphere in accordance with Practice D 6054. Place the coils in an oven in the same position as drained. Cure at the temperature and for the time recommended by the manufacturer. Reverse dip the coils following the preceding steps if testing a solvent-containing varnish.

8.7 When testing solventless varnishes the twisted coils are single dipped.

9. Procedure

9.1 Follow the procedure as required in Test Method D 2519.

10. Report

10.1 Report the data as required in Test Method D 2519.

11. Precision and Bias ⁵

11.1 *Precision*—Data from an interlaboratory study of this test method are as follows:

Data from six laboratories, 10 individual values from each laboratory per condition tested.

Tested at 25°C		
Mean		51 lbf (227 N)
Standard Deviation		8.1 lbf (36 N)
95 % Confidence level		15.9 lbf (71 N)
Tested at 150°C		
Mean		31 lbf (138 N)
Standard Deviation		4.4 lbf (20 N)
95 % Confidence level		8.6 lbf (38 N)

11.2 *Bias*—A statement of bias is not possible due to the lack of a standard reference material.

12. Keywords

12.1 bond strength; electrical insulating; magnet wire; twisted coil; varnish

⁵ Supporting data are available from ASTM Headquarters. Request RR:D-9-1027.

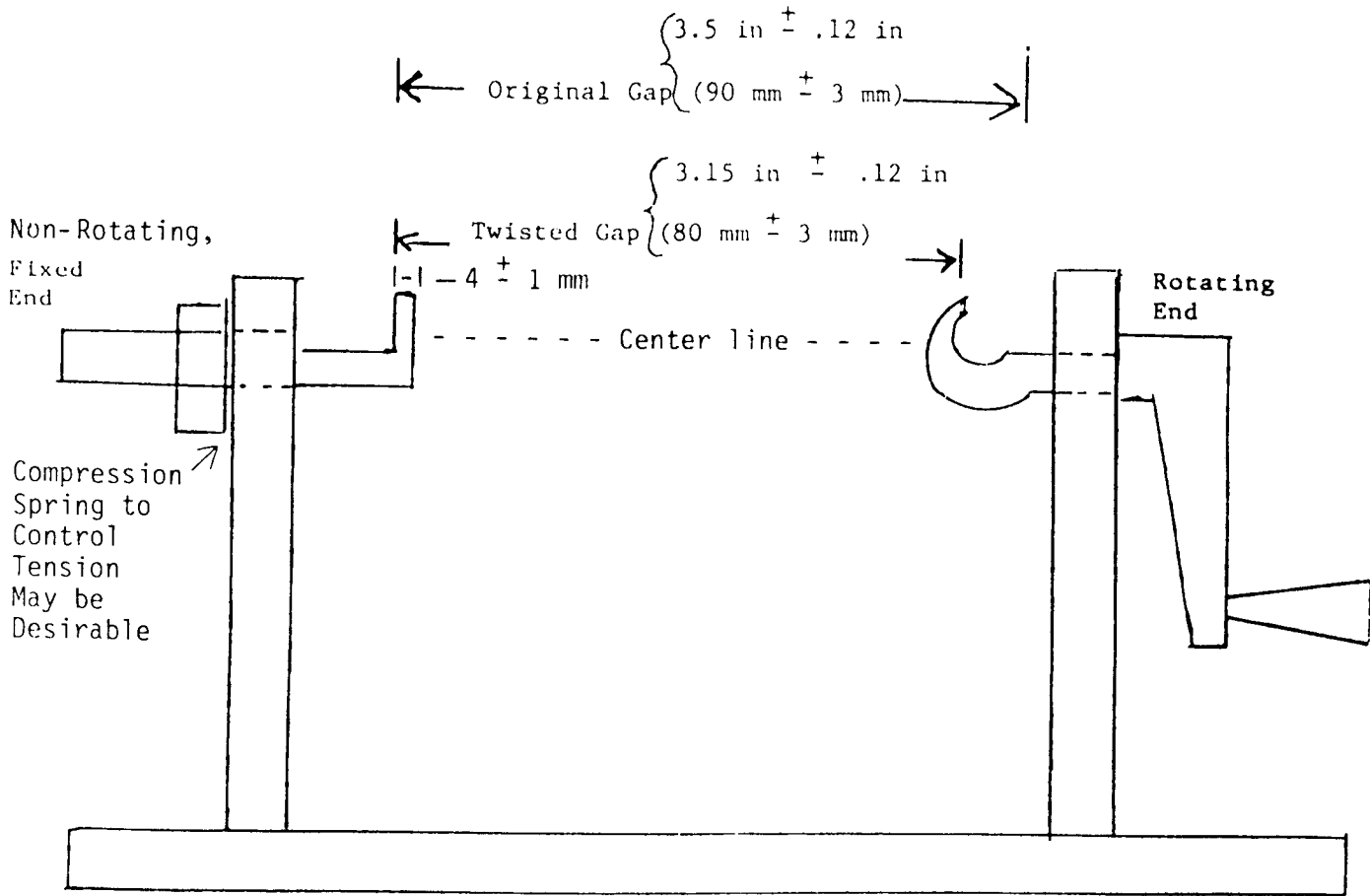

FIG. 3 Coil Twister

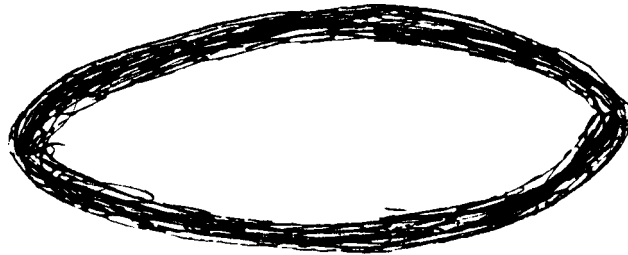

FIG. 4 Oval-Shaped Coil

The American Society for Testing and Materials takes no position respecting the validity of any patent rights asserted in connection with any item mentioned in this standard. Users of this standard are expressly advised that determination of the validity of any such patent rights, and the risk of infringement of such rights, are entirely their own responsibility.

This standard is subject to revision at any time by the responsible technical committee and must be reviewed every five years and if not revised, either reapproved or withdrawn. Your comments are invited either for revision of this standard or for additional standards and should be addressed to ASTM Headquarters. Your comments will receive careful consideration at a meeting of the responsible technical committee, which you may attend. If you feel that your comments have not received a fair hearing you should make your views known to the ASTM Committee on Standards, at the address shown below.

This standard is copyrighted by ASTM, 100 Barr Harbor Drive, PO Box C700, West Conshohocken, PA 19428-2959, United States. Individual reprints (single or multiple copies) of this standard may be obtained by contacting ASTM at the above address or at 610-832-9585 (phone), 610-832-9555 (fax), or service@astm.org (e-mail); or through the ASTM website (www.astm.org).