



Standard Test Method for Heat Release, Flame Spread, Smoke Obscuration, and Mass Loss Testing of Insulating Materials Contained in Electrical or Optical Fiber Cables When Burning in a Vertical Cable Tray Configuration¹

This standard is issued under the fixed designation D 5537; the number immediately following the designation indicates the year of original adoption or, in the case of revision, the year of last revision. A number in parentheses indicates the year of last reapproval. A superscript epsilon (ϵ) indicates an editorial change since the last revision or reapproval.

1. Scope

1.1 This is a fire-test-response standard.

1.2 This test method provides a means to measure the heat released and smoke obscuration by burning the electrical insulating materials contained in electrical or optical fiber cables when the cable specimens, excluding accessories, are subjected to a specified flaming ignition source and burn freely under well ventilated conditions. Flame propagation cable damage, by char length, and mass loss are also measured.

1.3 This test method provides two different protocols for exposing the materials, when made into cable specimens, to an ignition source (approximately 20 kW), for a 20 min test duration. Use it to determine the heat release, smoke release, flame propagation and mass loss characteristics of the materials contained in single and multiconductor electrical or optical fiber cables.

1.4 This test method does not provide information on the fire performance of materials insulating electrical or optical fiber cables in fire conditions other than the ones specifically used in this test method nor does it measure the contribution of the materials in those cables to a developing fire condition.

1.5 Data describing the burning behavior from ignition to the end of the test are obtained.

1.6 This test equipment is suitable for ~~making other measurements, including the smoke released by the burning specimen (Test Method D 5424)~~ and measuring the concentrations of certain toxic gas species in the combustion gases (see Appendix X4).

1.7 The values stated in SI units are the standard (see IEEE/ASTM SI 10); the values stated in parentheses are for information only.

1.8 *This standard measures and describes the response of materials, products, or assemblies to heat and flame under controlled conditions, but does not by itself incorporate all factors required for fire hazard or fire risk assessment of the materials, products or assemblies under actual fire conditions.*

1.9 Fire testing of products and materials is inherently hazardous. Employ adequate safeguards for personnel and property in conducting these tests.

1.10 *This standard does not purport to address all of the safety concerns, if any, associated with its use. It is the responsibility of the user of this standard to establish appropriate safety and health practices and determine the applicability of regulatory limitations prior to use.*

¹ This test method is under the jurisdiction of ASTM Committee ~~D-9~~ D09 on Electrical and Electronic Insulating Materials and is the direct responsibility of Subcommittee D09.21 on Fire Performance Standards.

Current edition approved ~~Oct. 10, 1999~~; Dec. 1, 2003. Published ~~December 1999~~; January 2004. Originally published as D 5537 – 94, approved in 1994. Last previous edition approved in 1999 as D 5537 – 989.

2. Referenced Documents

2.1 *ASTM Standards:*²

D 1711 Terminology Relating to Electrical Insulation

D 5424 Test Method for Smoke Obscuration of Insulating Materials Contained in Electrical or Optical Fiber Cables When Burning in a Vertical Cable Tray Configuration

E 84 Test Method for Surface Burning Characteristics of Building Materials

E 176 Terminology of Fire Standards⁴

E 603 Guide for Room Fire Experiments

E 800 Guide for Measurement of Gases Present or Generated During Fires

E 1354 Test Method for Heat and Visible Smoke Release Rates for Materials and Products Using an Oxygen Consumption Calorimeter

E 1537 Test Method for Fire Testing of Upholstered Furniture

E 2067 Practice for Full-Scale Oxygen Consumption Calorimetry Fire Tests

IEEE/ASTM SI 10 Standard for Use of the International System of Units (SI): The Modern Metric System

2.2 *NFPA Standards:*

ANSI/NFPA 70, National Electrical Code, National Fire Protection Association³

NFPA 265, Standard Methods of Fire Tests for Evaluating Room Fire Growth Contribution of Textile Wall Coverings³

NFPA 286, Standard Methods of Fire Tests for Evaluating Contribution of Wall and Ceiling Interior Finish to Room Fire Growth³

2.3 *Underwriters Laboratories Standards:*

UL 1581: Reference Standard for Electrical Wires, Cables, and Flexible Cords, ANSI/UL 1581⁴

UL 1685: Standard Vertical Tray Fire Propagation and Smoke Release Test for Electrical and Optical Fiber Cables⁴

2.4 *Canadian Standards Association Standard:*

CSA FT4, Vertical Flame Tests: Cables in Cable Trays, Section 4.11.4 in Standard C 22.2 No. 0.3-M1985, 0.3, Test Methods for Electrical Wires and Cables⁵

2.5 *IEEE Standard:*

IEEE 1202: Standard for Flame Testing of Cables for Use in Cable Tray in Industrial and Commercial Occupancies⁶

2.6 *ISO Standard:*

ISO 9705, Fire Tests—Full Scale Room Test for Surface Products⁷

3. Terminology

3.1 For definitions of terms used in this test method and associated with fire issues refer to Terminology E 176. For definitions of terms used in this test method and associated with electrical insulation refer to Terminology D 1711.

3.2 *Definitions of Terms Specific to This Standard:*

3.2.1 *heat release rate, n*—the heat evolved from the specimen, per unit of time.

3.2.2 *sample, n*—an amount of the cable type and construction to be tested, which is representative of the product for test.

3.2.3 *smoke obscuration, n*—reduction of light transmission by smoke, as measured by light attenuation.

3.2.4 *specimen, n*—the individual length of cable, or cable bundle, to be placed in the cable tray, which is representative of the product to be tested.

4. Summary of Test Method

4.1 This fire-test-response standard determines a number of fire-test-response characteristics associated with burning the materials insulating electrical or optical fiber cables, made into cable specimens, and located in a vertical cable tray and ignited with a propane gas burner. The main fire properties measured are the rate of heat release and its amount. Associated with these measurements, the test procedure also determines flame propagation cable damage (by char length), smoke obscuration, and mass loss of specimen. The apparatus described in this test method is also suitable for measuring smoke obscuration (Test Method D 5424) and rates and concentrations of gaseous combustion products released.

4.2 The vertical cable tray that holds the specimen is located in an enclosure of specified dimensions.

² For referenced ASTM standards, visit the ASTM website, www.astm.org, or contact ASTM Customer Service at service@astm.org. For *Annual Book of ASTM Standards*, Vol 14.01, volume information, refer to the standard's Document Summary page on the ASTM website.

Annual Book of ASTM Standards, Vol 14.02.

³ Available from National Fire Protection Association, Batterymarch Park, Quincy, MA 02269.

Annual Book of ASTM Standards, Vol 04.07.

⁴ Available from Underwriters Laboratories, Inc., 333 Pfingsten Rd., Northbrook, IL 60062.

Annual Book of ASTM

⁵ Available from Canadian Standards Association, 178 Rexdale Blvd., Rexdale, Ontario, Canada, M9W 1R3.

⁶ Available from National Fire Protection Association, Batterymarch Park, Quincy, MA 02269; the Institute of Electrical and Electronic Engineers, 345 East 47th St., New York, NY 10017.

⁷ Available from Underwriters Laboratories, Inc., 333 Pfingsten Rd., Northbrook, IL 60062; (ISO), P.O. Box 56, CH-1211, Geneva, Switzerland.

4.3 A hood, connected to a duct is located above the fire enclosure. Heat and gas release analysis instrumentation is placed in the duct. Smoke release instrumentation (optional) is also placed in the duct.

4.4 Two different test procedures are specified, which differ in the burner used and in the electrical or optical fiber cable loading. These reflect details of four existing test methods: UL 1581 (vertical tray flammability test, protocol A) and CSA Standard C 22.2 No. 0.3-M1985 (FT-4 0.3 (FT4 vertical tray flammability test) or IEEE 1202 (protocol B) and UL 1685 and Test Method D 5424 (both protocols, for smoke obscuration only).

4.5 Information specific to the individual protocols is found in 7.67, 7.89, and 11.1.

5. Significance and Use

5.1 This test method provides a means to measure a variety of fire-test-response characteristics associated with heat and smoke release and resulting from burning the materials insulating electrical or optical fiber cables, when made into cables and installed on a vertical cable tray. The specimens are allowed to burn freely under well ventilated conditions after ignition by means of a propane gas burner.

5.2 The rate of heat release often serves as an indication of the intensity of the fire generated. General considerations of the importance of heat release rate are discussed in Appendix X1 and considerations for heat release calculations are in Appendix X2.

5.3 Other optional fire-test-response characteristics that are measurable by this test method are useful to make decisions on fire safety. ~~Test Method D 5424 uses the apparatus described here~~ The test method is also used for measuring smoke obscuration. The apparatus described here is also useful to measure gaseous components of smoke; the most important gaseous components of smoke are the carbon oxides, present in all fires. The carbon oxides are major indicators of the completeness of combustion and are often used as part of fire hazard assessment calculations and to improve the accuracy of heat release measurements.

5.4 Test Limitations:

5.4.1 The fire-test-response characteristics measured in this test are a representation of the manner in which the specimens tested behave under certain specific conditions. Do not assume they are representative of a generic fire performance of the materials tested when made into cables of the construction under consideration.

5.4.2 In particular, it is unlikely that this test is an adequate representation of the fire behavior of cables in confined spaces, without abundant circulation of air.

5.4.3 This is an intermediate-scale test, and the predictability of its results to large scale fires has not been determined. Some information exists to suggest validation with regard to some large-scale scenarios.

6. Test Specimens

6.1 Use multiple lengths of electrical or optical fiber cable as test specimens.

6.2 The mounting of the specimen on the cable tray is specified in 7.89.

7. Apparatus

7.1 Enclosure:

7.1.1 The enclosure in which the specimen is tested is shown in Fig. 1.

7.1.2 The enclosure has floor dimensions of $2.44\text{ m} \pm 25\text{ mm}$ by $2.44\text{ m} \pm 25\text{ mm}$, with a height of $3.35\text{ m} \pm 25\text{ mm}$ (8 ft \pm 1 in. by 8 ft \pm 1 in. by 11 ft \pm 1 in. high). On top of the walls there is a pyramidal collection hood with a collection box.

7.1.2.1 Other enclosure sizes, such as 2.4 by 2.4 by 2.4 m (8 by 8 by 8 ft) or the 3 m cube are permitted, provided that the internal volume of the enclosure, exclusive of the pyramidal hood, ranges between 14.5 m^3 (512 ft³) and 36 m^3 (1272 ft³), the floor area ranges between 6 m^2 (64 ft²) and 9 m^2 (97 ft²), and the maximum air movement within the enclosure complies with 7.1.12 (Note 1).

NOTE 1—There is, as yet, not enough information as to the equivalence on smoke release between the various facilities. Further work needs to be done to confirm this.

7.1.2.2 In case of disputes, the referee method is the tests conducted using the enclosure in 7.1.2.

7.1.3 *Walls*—The maximum conductive heat flux loss of the walls of the structure is $6.8\text{ W}/(\text{m}^2\text{K})$ (30 Btu/h-ft²), based upon an inside wall temperature of 38°C (100°F) and an outside air temperature of 24°C (75°F). Paint the interior surface of the walls flat black. Any materials of construction that meet the preceding requirements are acceptable. Two examples of acceptable construction materials are nominally 152 mm (6 in.) thick concrete masonry blocks (density: 1700 kg m^{-3} (106 lb ft⁻³) and thermal conductivity nominally $k = 1.75\text{ W}/(\text{mK})$, at 21°C; 12.13 Btu in./ft² h°F, at 70°F) or nominally 13 mm (0.5 in.) gypsum board, with $89 \pm 6\text{ mm}$ ($3.5 \pm 0.25\text{ in.}$) of standard fiberglass insulation, with an R value of $1.94\text{ m}^2\text{ K}/\text{W}$ (which corresponds in practical units to an R value of 11 hft² °F/Btu). Windows for observation of the fire test are allowed in the walls; ensure that the total area of the windows does not exceed 1.86 m^2 (20 ft²).

7.1.3.1 Select materials of construction which can withstand the high temperatures and presence of open flame within the test enclosure and duct.

7.1.4 Provide air intakes at the base of two opposite walls, one of which contains the access door. Ensure that the total cross sectional area of the air intakes is $1.45 \pm 0.03\text{ m}^2$ ($2250 \pm 50\text{ in.}^2$), and that the intake areas are divided approximately equally. Fig. 1 shows dimensions for the air intakes installed in the walls. Air intakes are not permitted in either of the other two walls.

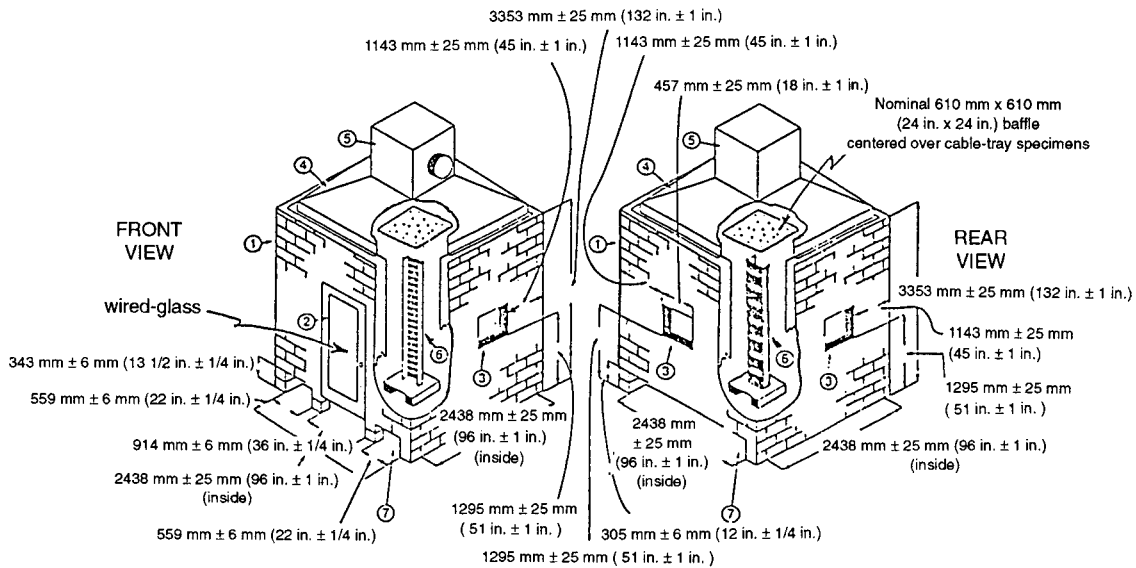

1. Enclosure: an acceptable construction consists of concrete masonry blocks, laid up with mortar, nominally 203 mm high by 406 mm wide by 152 mm thick (8 by 16 by 6 in.).
2. Wired-glass door, for access and observation. The overall size of the door is 2.1 m high and 0.9 m wide (84 by 36 in.).
3. Steel-framed wired-glass observation windows, 457 mm (18 in.) per side (optional).
4. Truncated-pyramid stainless steel hood, with each side sloped 40°.
5. Cubical collection box, 914 mm (36 in.) per side, with exhaust duct centered on one side.
6. Cable tray, mounted vertically in the center of the enclosure. Tray base (stand) is optional.
7. Air intake openings.

FIG. 1 Cable Test Enclosure

7.1.5 Construct a door with wired glass and locate it as shown in Fig. 1. The door is 900 ± 25 mm wide and 2100 ± 25 mm high (35 ± 1 in. by 83 ± 1 in.), with an overall conductive heat flux loss no greater than that of the walls, that is, $6.8 \text{ W}/(\text{m}^2 \text{ K})$ ($30 \text{ Btu}/\text{h}\text{-ft}^2$). A steel framed wired glass door will meet these requirements. Adequately seal the sides and top of the door to prevent drafts.

7.1.6 Construct a truncated pyramid stainless steel hood, formed as shown in Fig. 1, and locate it on top of the enclosure walls. Make the slope on each side of the hood 40°. Form a seal between the hood and the walls; a compressible inorganic batting as gasket is suitable.

7.1.7 Insulate the exterior of the hood to make an overall conductive heat loss no greater than that of the walls.

7.1.8 Locate a cubical stainless steel collection box, 910 ± 25 mm (36 ± 1 in.), on a side on top of the exhaust hood, with a nominal 410 ± 25 mm (16 ± 1 in.) diameter stainless steel pipe exhaust duct centered in one side.

7.1.9 Install the exhaust duct horizontally and connect it to the plenum of the hood.

7.1.10 Construct a square $610 \text{ mm} \pm 25 \text{ mm}$ (24 ± 1 in.) baffle, centered over the cable tray. An acceptable height is 300 to 400 mm (12 to 15 in.) above the tray.

7.1.11 Construct a collection-exhaust system, as explained in 7.2 and Annex A2.

7.1.12 Ensure that the maximum air movement within the enclosure, with only the intake and exhaust openings open, the exhaust fan on, and the burner off, does not exceed 1 m s^{-1} (3.3 ft s^{-1}), as measured by a vane-type anemometer in the areas in 7.1.12.1 and 7.1.12.2:

7.1.12.1 At the floor level where the burner is positioned during the test, and

7.1.12.2 At 1.50 ± 0.05 m ($4.9 \text{ ft} \pm 2$ in.) above the enclosure floor, where the cable tray is positioned during the test.

7.2 Exhaust Collection System:

7.2.1 Construct the exhaust collection system containing, as a minimum: a blower, a steel hood, a duct, a bidirectional probe, thermocouple(s), ~~and an oxygen measurement system, and a smoke obscuration measurement system (white light photocell lamp/detector or laser).~~ Optional components of the exhaust collection system include a system for combustion gas sampling and analysis ~~and a smoke obscuration measurement analysis.~~ Construct the exhaust collection system ~~(white light photocell lamp/detector or laser).~~ as explained in Annex A2 and Annex A3.

7.2.2 Ensure that the system for collecting the smoke (which includes gaseous combustion products) has sufficient exhaust capacity and is designed in such a way that all of the combustion products leaving the burning specimen are collected. Design the capacity of the evacuation system such that it will exhaust minimally all combustion gases leaving the cable specimen (see also Annex A2). Make the exhaust system capacity at least $2.7 \text{ m}^3 \text{ s}^{-1}$ ($340,000 \text{ ft}^3 \text{ h}^{-1}$) at normal pressure and at a temperature of $25 \pm 2^\circ\text{C}$ ($77 \pm 4^\circ\text{F}$).

7.2.3 Place probes for sampling of combustion gas and for measurement of flow rate in accordance with 7.3.

7.2.4 Make all measurements of gas concentrations or flow rates at a position in the exhaust duct where the exhaust is uniformly mixed so that there is a nearly uniform velocity across the duct section (turbulent flow). Make the minimum straight section before the measuring system at least 8 times the inside diameter of the duct, to ensure the exhaust is uniformly mixed.

7.3 *Instrumentation in Exhaust Duct:*

7.3.1 The following specifications are minimum requirements for exhaust duct instrumentation. Additional information is found in Annex A1 through Annex ~~A3~~-A4.

7.3.2 *Flow Rate:*

7.3.2.1 Measure the volumetric flow rate in the exhaust duct by means of a bidirectional probe, or an equivalent measuring system, with an accuracy of at least $\pm 6\%$ (see Annex A1 through Annex A3~~4~~). The response time to a stepwise change of the duct flow rate shall not exceed 5 s, to reach 90 % of the final value.

7.3.2.2 Use a bidirectional probe or an equivalent measuring system to measure pressure in the duct. Locate the probe shown in Fig. 2 in the exhaust duct, at least 4.6 m (15 ft) but no more than 13.7 m (45 ft) from the centerline of the collection box.

7.3.2.3 Build a stainless steel bidirectional probe consisting of a cylinder 44 mm (1.75 in.) long and 22 mm (0.875 in.) in inside diameter with a solid diaphragm in the center. The pressure taps on either side of the diaphragm also provide support for mounting the probe. Position the long axis of the probe along the centerline of the duct. Connect the taps to a pressure transducer which can detect pressure differences as small as 0.25 Pa (0.001 in. of water).

7.3.2.4 Measure the mass flow rate as indicated in Annex ~~A3~~-A4.

7.3.2.5 Measure gas temperatures in the vicinity of the probe with Inconel sheathed Chromel-Alumel thermocouples. Ensure that the thermocouple does not disturb the flow pattern around the bidirectional probe. Further details are discussed in A1.3.

7.4 *Smoke Obscuration Measurements :*

7.4.1 Install an optical system for measurement of light obscuration across the centerline of the exhaust duct. Determine the optical density of the smoke by measuring the light transmitted with a photometer system consisting of a white light source and a photocell/detector or a laser system for measurement of light obscuration across the centerline of the exhaust duct. Locate the system so that it is preceded by at least eight diameters of duct without bends, to ensure a nearly uniform velocity across the duct section. If the system is positioned at a different location, demonstrate the achievement of equivalent results.

7.4.2 One photometer system found suitable consists of a lamp, lenses, an aperture and a photocell (see Fig. 3 and Annex A3). Construct the system so that soot deposits on the optics during a test do not reduce the light transmission by more than 5 %.

7.4.2.1 Alternatively, instrumentation constructed using a 0.5 to 2.0 mW helium-neon laser, instead of a white light system is also acceptable. See Fig. 4 and Annex A3 for further details. White light and laser systems give similar results (1-5)⁸.

7.5 *Combustion Gas Analysis:*

7.45.1 *Sampling Line:*

7.45.1.1 Construct the sampling line tubes using a material which is not affected by the combustion gas species, thereby influencing the concentration of the combustion gas species to be analyzed. The recommended sequence of the gas train is: sampling probe, soot filter, cold trap, gas path pump, vent valve, plastic drying column and carbon dioxide removal columns (if used), flow controller and oxygen analyzer. Each analyzer in the gas train shall also include appropriate spanning and zeroing facilities.

7.45.1.2 Locate the sampling probe in a position where the exhaust duct flow is well mixed. Use a probe with a cylindrical cross section to minimize disturbance of the air flow in the duct. Collect the gas samples along the whole diameter of the exhaust duct.

7.45.1.3 Manufacture the sampling line, see Fig. ~~3~~ 5, from corrosion resistant material, for example polytetrafluoroethylene. Remove the particulates contained in the combustion gases with inert filters to the degree required by the gas analysis equipment.

⁸ Available from Canadian Standards Association, 178 Rexdale Blvd., Rexdale, Ontario, Canada, M9W 1R3.

⁸ The boldface numbers in parentheses refer to the list of references at the end of this test method.

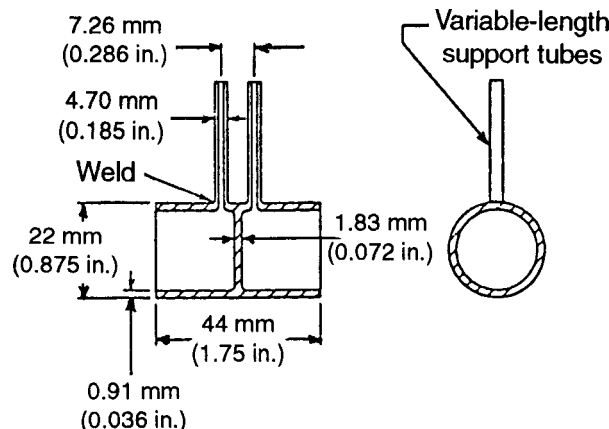

FIG. 2 Bidirectional Probe

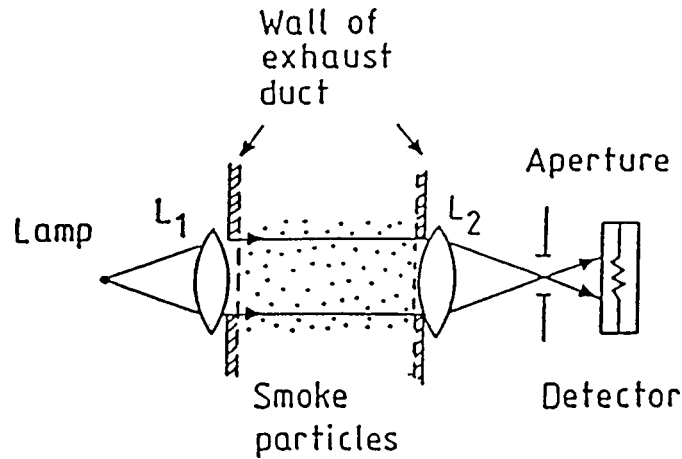

FIG. 3 Optical System

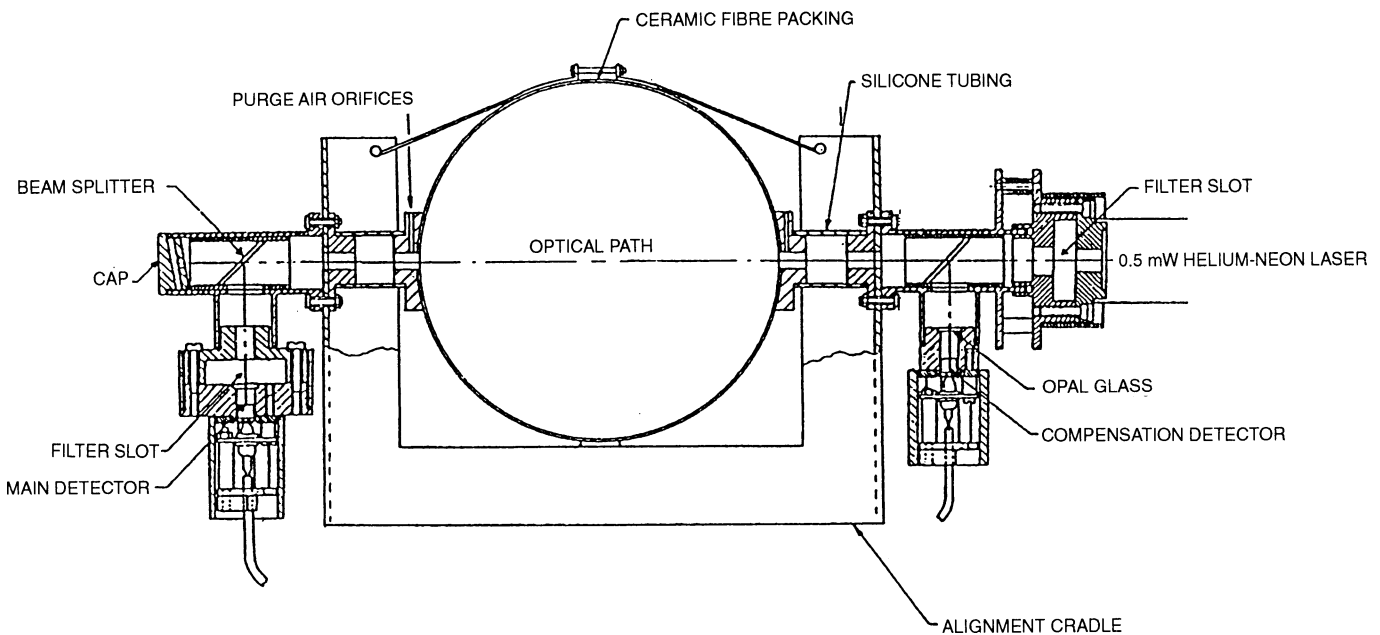

FIG. 4 Laser Extinction Beam

Preferably filter the gases in more than one step. Cool the gas mixture to a maximum of 10°C and dry the gas samples completely before the smoke reaches each analyzer.

7.45.1.4 Use a pump for the combustion gases which does not allow the gases to contact oil, grease or similar products, all of which can contaminate the gas mixture. A membrane pump is suitable.

7.45.1.5 A suitable sampling probe is shown in Fig.-4 6. This sampling probe is of the bar type. Ring type sampling probes are also acceptable, although they do not collect gas samples across the full diameter of the duct. The sampling line is shown in Fig. 3- 5. A suitable pump has a capacity of 10 to 50 L min⁻¹ at 10 kPa (minimum), as each gas analysis instrument consumes about 1 L min⁻¹. A pressure differential of at least 10 kPa, as generated by the pump, reduces the risk of smoke clogging of the filters. Turn the intake of the sampling probe downstream to avoid soot clogging the probe.

7.45.1.6 Install a soot filter, capable of removing all particles >25µm in size.

7.45.1.7 A refrigerated column is the most successful approach to cool and dry the gases. Provide a drain plug to remove the collected water from time to time. Alternative devices are also acceptable.

7.45.1.8 If carbon dioxide is to be removed, it is important to use carbon dioxide removal media, as indicated in Fig.-3 5.

7.45.2 Oxygen Measurement:

7.45.2.1 Measure the oxygen concentration with an accuracy of at least ± 0.04 % of full scale in the output range of 0 to 21 vol % oxygen, or ±0.01 vol % oxygen, in order to have adequate measurements of rate of heat release. Take the combustion gas sample from the end of the sampling line. Calculate the time delay, including the time constant of the instrument, from the test room; it is a function of the exhaust duct flow rate. This time delay shall not exceed 60 s.

7.45.2.2 Use an oxygen analyzer, meeting the specifications of 7.45.2.1, preferably of the paramagnetic type.

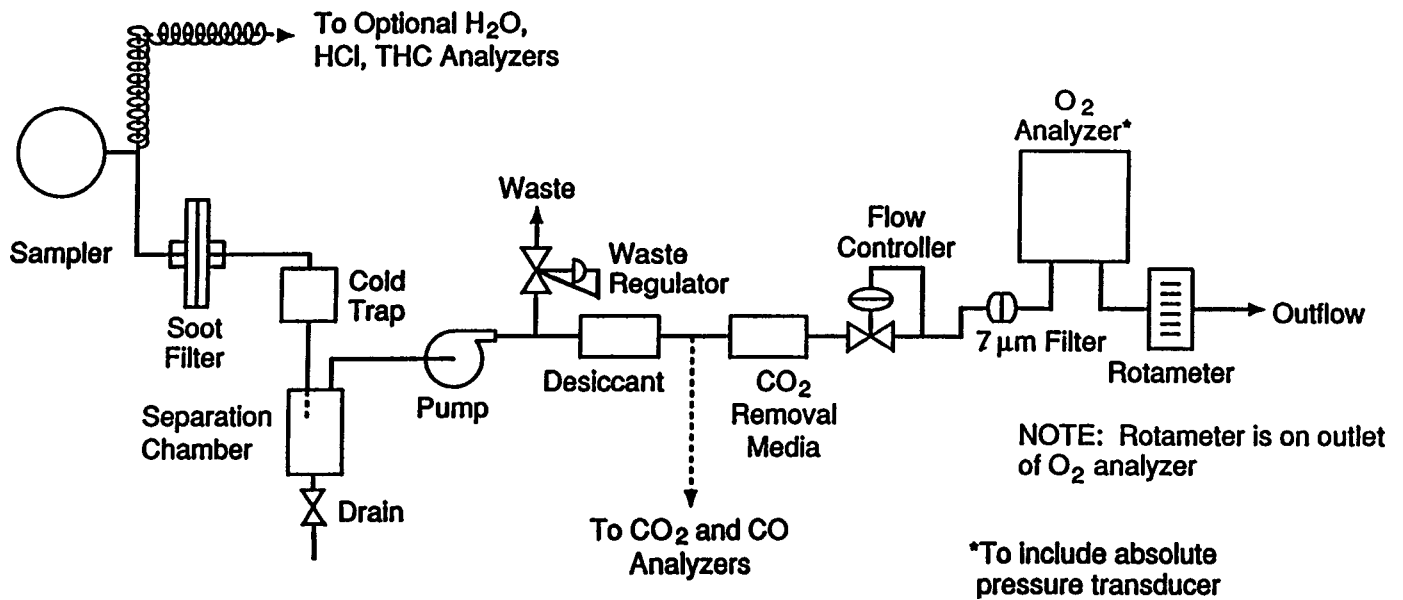

FIG. 3.5 Schematic Diagram of Gas Analysis System

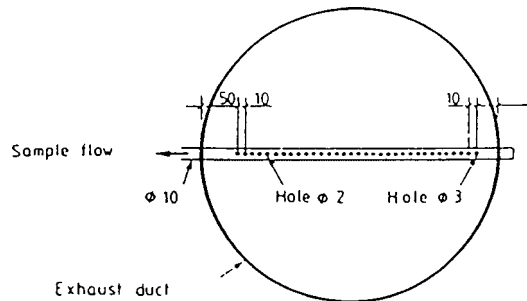

FIG. 4.6 Sampling Probe

7.5-9

7.6 Cable Tray:

7.56.1 Use a steel ladder cable tray, 300 ± 25 mm (12 ± 1 in.) wide, 75 ± 6 mm (3 ± 0.25 in.) deep, and 2440 ± 25 mm (8 ft ± 1 in.) long. Arrange the tray so that the burner flame will impinge on the cables midway between rungs.

7.56.1.1 Each rung in the tray is to measure 25 ± 6 mm (1 ± 0.25 in.) in the direction parallel to the length of the tray and 13 ± 3 mm (0.5 ± 0.125 in.) in the direction parallel to the depth of the tray.

7.56.1.2 Space the rungs 230 ± 13 mm (9 ± 0.5 in.) apart (measured center to center).

7.56.1.3 Attach the rungs to the side rails.

7.56.1.4 Mount the cable tray vertically in the center of the enclosure. Position the tray on a tray base (stand) which is to be no higher than 150 ± 25 mm (6 ± 1 in.).

7.67 Burner:

7.67.1 Use a 254-mm (10-in.) strip or ribbon type propane gas burner with an air/gas Venturi mixer.

7.67.2 The flame producing surface of the burner consists essentially of a flat metal plate that is 341 mm ($13\frac{7}{16}$ in.) long and 30 mm ($1\frac{5}{32}$ in.) wide. The plate has an array of 242 holes drilled in it. The holes are 1.35 mm (metric drill size: 1.35 mm) or 0.052 in. (No. 55 drill) in diameter, on 3.2-mm (0.125-in.) centers in three staggered rows of 81, 80 and 81 holes each, to form an array measuring 257 mm ($10\frac{1}{8}$ in.) by 5 mm ($\frac{3}{16}$ in.). Center the array of holes on the plate (see Fig. 5.7).¹⁰

7.67.3 Protocol A:

7.67.3.1 Position the burner behind the cable tray containing the specimen, with the flame-producing surface (face) of the burner vertical and its long dimension horizontal and with the 257-mm ($10\frac{1}{8}$ -in.) dimension of the array of holes spaced 76 ± 5 mm (3.0

⁹ Available from the Institute of Electrical and Electronic Engineers, 345 East 47th St., New York, NY 10017.

⁹ A Siemens Oxymat 2 or a Servomex 540 A are suitable.

¹⁰ Available from (ISO), P.O. Box 56, CH-1211, Geneva, Switzerland.

¹⁰ One satisfactory system is a burner supplied by American Gas Furnace Company, Inc., of Elizabeth, NJ, Catalog No. 10L 11-55, with an air/gas Venturi mixer, Catalog No. 14-18. Equivalent systems are probably available.

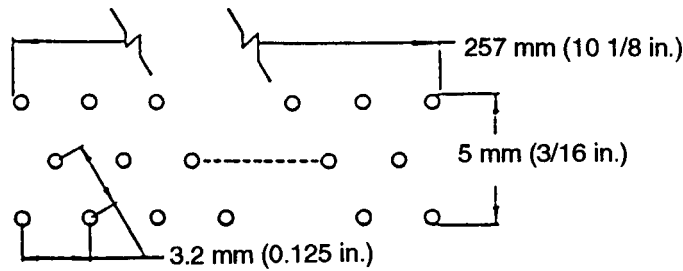

FIG. 5.7 Burner Holes

± 0.2 in.) from the specimens in the tray and centered midway between the side rails of the tray. Position the centerpoint of the array of holes at 460 mm (18 in.) above the bottom end of the tray and specimen and midway between two rungs. Support the burner in a manner that allows its quick removal and precise repositioning of the burner to the position described. The tray faces the door.

7.67.4 Protocol B:

7.67.4.1 Mount the burner on a stand and place it $20 \pm 2^\circ$ from the horizontal with the burner ports up, in front of the cable tray. Locate the major axis of the burner ports 305 ± 25 mm (12 ± 1 in.) above the base of the cable tray and parallel to the cable tray rungs during the fire test (Fig.-6.8). The tray faces away from the door.

7.67.4.2 Attach a guide to the burner or stand such that the leading edge of the burner face is located quickly and accurately 75 ± 5 mm (3 ± 0.2 in.) horizontally away from the nearest surface of the cables during the burn period of the test.

7.67.5 Insert a flowmeter in both the propane and the air lines feeding the burner to measure the flow rates of these gases during the test.

7.67.6 Use a propane flowmeter capable of measuring at least $230 \text{ cm}^3 \text{ s}^{-1}$ ($29 \text{ ft}^3 \text{ h}^{-1}$) and an air flowmeter of at least $1330 \text{ cm}^3 \text{ s}^{-1}$ ($170 \text{ ft}^3 \text{ h}^{-1}$). Make flow rate measurements with an accuracy of $\pm 3\%$. Mass flow controllers with recordable outputs are permitted alternatives.

7.67.7 Supply compressed air to the burner, either bottled or from a compressed air system. Filter the air supply sufficiently so as to eliminate any contaminants that might affect the test results.

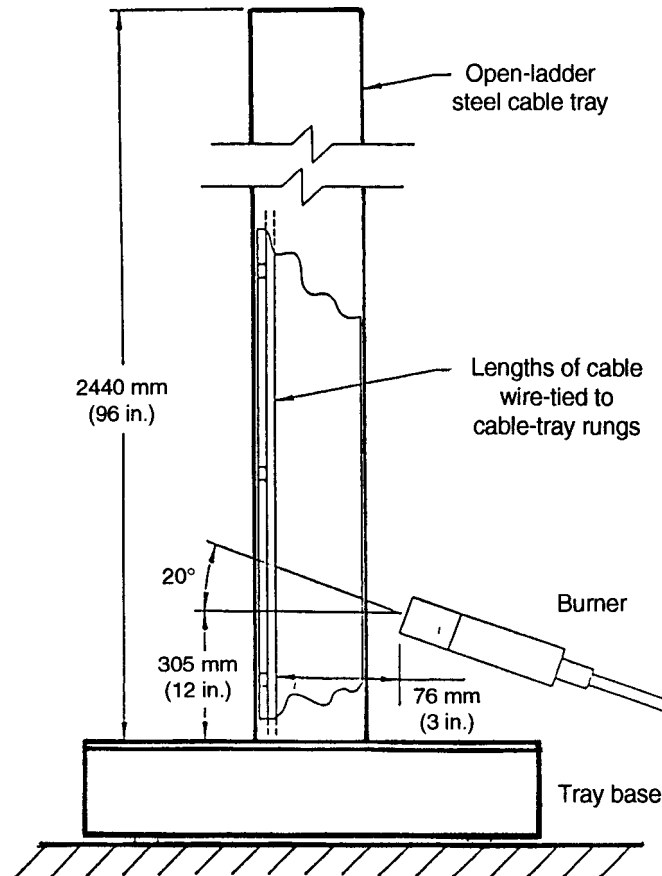

FIG. 6.8 Protocol B Cable Tray

7.67.8 Use air with a dew point no greater than 0°C (32°F), as measured by a dew point measuring device.¹¹

7.67.9 Use CP grade propane (99 % pure), having a heat content of approximately 50.8 MJ kg⁻¹ (21.7 k Btu lb⁻¹) (93.0 MJ m⁻³ at 20°C, 101 kPa), for the burner.

7.67.10 Use a propane flow rate of 220 ± 8 cm³ s⁻¹ (28 ± 1 ft³ h⁻¹) when corrected to standard temperature and pressure (20°C, 101 kPa). This propane flow will provide a theoretical heat output of 20 kW (approximately 70 000 Btu h⁻¹). The actual heat output is less, due to incomplete combustion of the propane at the burner. Accurate flow rates of propane gas are calculated using the mass flow rate equations.

7.67.11 Use an air flow rate to the burner of 1280 ± 80 cm³ s⁻¹ (163 ± 10 ft³ h⁻¹) when corrected to standard temperature and pressure.

7.78 *Mass Loss Measuring Device* :

7.78.1 Use a mass measuring device, such as a load cell, to continuously measure the mass loss of the burning specimen.

7.78.2 The mass measuring device needs to measure the specimen mass with an accuracy of at least ±45 g (1.6 oz) up to at least 90 kg (198 lb) of specimen mass. Install it in such a way that the heat from the burning specimen and any eccentricity of the load does not affect the accuracy. Avoid range shifts during measurements. Protect all parts of the weight measuring device by a thermal barrier.

7.78.3 There are two alternative locations for the mass measuring device, as described in 7.78.4 to 7.78.5 and in 7.78.6.

7.78.4 *Alternative 1*—Place the mass measuring device under a platform, with a thermal barrier of dimensions 0.3 ± 0.05 m by 0.3 ± 0.05 m (1 ft ± 2 in. by 1 ft ± 2 in.) and of a non-combustible material, for example calcium silicate boards. Provide the platform with sides of 0.1 m ± 10 mm (4 ± 0.4 in.) height in order to prevent melting or falling material from the tested specimens from falling off the thermal barrier.

7.78.5 Do not exceed 0.5 m (20 in.) from the upper surface of the thermal barrier to floor level. Shield the area between the thermal barrier and the floor level to avoid lifting forces due to fire induced air flow that could influence the measurement. Ensure that there are virtually no obstructions to the air supply for the test set-up.

7.78.6 *Alternative 2*—Place the mass measuring device in the hood and hang the cable tray from it. Thermal and combustion gas protection of the mass measuring equipment is still required.

7.78.7 Place a square galvanized steel platform under the cable tray. The platform shall be constructed of nominally 1.6 mm (1/16 in.) thick steel, and have dimensions of no less than 1.0 by 1.0 m (approximately 39 in. by 39 in.), with a uniform raised lip, 100 mm (approximately 4 in.) high, on each side, to catch falling material. The platform shall be covered by a tight fitting sheet of standard gypsum board, of nominally 13 mm (0.5 in.) thickness. The platform shall protect the load cell, if it is placed underneath the cable tray. The gypsum board shall be clean before the start of a test. If the sheet used has been damaged it shall be replaced.

NOTE 2—A square galvanized steel platform of dimensions of up to 1.22 m by 1.22 m (approximately 4 ft by 4 ft) with a raised lip is also acceptable.

7.89 *Cable Mounting*:

7.89.1 *Protocol A*—Fasten 2440 ± 10-mm (96 ± 0.5-in.) specimen lengths of finished cable in a single layer in the tray by means of steel or copper wire, not larger than 2.1 mm² (14 AWG) in cross section, at their upper and lower ends and at two other equally spaced points along their lengths, with each cable vertical. Install as many specimens in the tray as will fit, spaced one half cable diameter apart, to fill the center 150 mm (6 in.) of the tray width.

7.89.1.1 Determine the number of specimen lengths for test using Eq 1:

$$N = [(4 \times 25.4)/D] + 0.33 \quad (1)$$

where:

N = number of cables (rounded up to the nearest whole number), and

D = diameter of the cable, mm.

7.89.2 *Protocol B*—Fasten 2440 ± 10 mm (96 ± 0.5 in.) specimen lengths of finished cable in the tray. Depending upon the outside diameter of the individual cables, the test specimen is to be either an individual length or a bundle of individual lengths. Center the specimens or specimen bundles in a single layer between the side rails of the cable tray. Ensure that the lower end of each specimen is no more than 100 mm (4 in.) above the bottom end of the cable tray. Attach each individual specimen or bundle of specimens separately to each rung of the cable tray using one wrap of a copper or steel wire tie not larger than 2.1 mm² (14 AWG) in diameter.

7.89.2.1 For cables smaller in diameter than 13 mm (0.5 in.), group the specimens into untwisted bundles (nominally circular) as shown in Table 1. Space the bundles one-half bundle diameter apart on the cable tray as measured at the point of attachment to the cable tray.

7.89.2.2 For cables 13 mm (0.5 in.) in diameter and larger, attach the individual specimens to the cable tray with spacings of 1/2 cable diameter, except do not exceed a spacing of 15 mm (0.6 in.). Table 2 shows the tray loading.

7.89.3 On flat cables, calculate the equivalent cable diameter using Eq 2

¹¹ A Siemens Oxymat 2 or a Servomex 540 A satisfactory system is Alnor Model 7000 U, No. 1999, but equivalent alternative systems are suitable, probably available.

TABLE 1 Tray Loading for Circular Cables Smaller than 13 mm (0.5 in.) in Diameter

Cable Diameter, mm		Number of Cables in Each Bundle	Number of Bundles in Tray
From	But Less Than		
11	13	3	7
9	11	3	8
6	9	3	10
5	6	7	9
3	5	19	8
0	3	19	13

TABLE 2 Tray Loading for Cables 13 mm (0.5 in.) in Diameter and Larger

Cable Diameter, mm		Number of Cables in Tray
From	But Less Than	
13	15	11
15	19	9
19	21	8
21	26	7
26	28	6
28	39	5
39	52	4
52	73	3
73	120	2

$$D = 1.128 \times \sqrt{(T \times W)} \quad (2)$$

where:

D = calculated equivalent cable diameter,

T = minor axis of the cable, and

W = major axis of the cable.

8. Calibration

8.1 Calibrate all instruments carefully with standard sources after initial installation. Among the instruments to be calibrated are load cells or weighing platforms, smoke meters, flow or velocity transducers, and gas analyzers. Perform recalibration tests on the entire system, for example using standard output burners.

8.2 Heat Release:

8.2.1 Perform the calibration of the heat release instrumentation in the exhaust duct by burning propane gas and comparing the heat release rates calculated from the metered gas input, and those calculated from the measured oxygen consumption. The value of net heat of combustion for propane is 46.5 MJ/kg. Position the burner in the same location that the cable tray will occupy during the test. Measure the gas flow rate at a pressure of 101 ± 5 kPa (standard atmospheric pressure, measured at the flow gage) and a temperature of $20 \pm 5^\circ\text{C}$. Use Eq A45.7 for calculation of heat release rate during calibration.

8.2.2 Obtain a minimum of two calibration points. Obtain a lower heat release rate value of 40 kW and then a higher heat release rate value of 160 kW. Approximate propane flow rates for any required heat release rate value are estimated using the following constant: 1.485 kW min/L, determined at a pressure of 101 ± 5 kPa (standard atmospheric pressure; measured at the flow gage) and a temperature of $20 \pm 5^\circ\text{C}$.

8.2.3 Take measurements at least once every 6 s and start 1 min prior to ignition of the burner. Determine the average rate of heat release over a period of at least 1 min by (1) the oxygen consumption method, and (2) calculating the heat release rate from the gas mass flow rate and the net heat of combustion. The two values must agree within 5 %. Make this comparison only after steady state conditions are reached.

8.2.4 Perform a calibration test in accordance with 8.2.1 and 8.2.3 prior to each continuous test series. Perform a full basic calibration on a new system or when modifications are introduced.

8.2.5 When calibrating a new system, or when modifications are introduced, check the response time of the measuring system by the following test sequence:

Time	Burner Output
0 to 5 min	0 kW
5 to 10 min	40 kW
10 to 15 min	160 kW
15 to 20 min	0 kW

The response of the system to a stepwise change of the heat output from the burner shall be a maximum of 12 s to 90 % of final value.

8.2.6 Perform the calibration in 8.2.5 at a duct air flow rate comparable to that to be used in the test procedure.

8.2.7 Determine the time average value, over 1 min, of rate of heat release at each minute. The difference between these time averaged measured rate of heat release values and the actual heat output from the burner, shall not be more than 10 % of the actual value.

8.3 *Mass Loss:*

8.3.1 Perform calibration of the mass measuring device by loading the weighing platform with known masses corresponding to the measuring range of interest, to ensure that the requirements of accuracy in 7.78.2 are fulfilled. Carry out this calibration daily, prior to testing.

8.4 *Smoke Release:*

8.4.1 Prior to the start of each day of testing, verify the linearity of the photometer system by interrupting the light beam with multiple calibrated neutral density filters to cover the range of the recording instrument. Use at least two neutral density filters of significantly different values, and also one for 100 % transmission. Ensure that the transmittance values measured by the photometer, using neutral density filters, are within ± 3 % of the specified value for each filter.

9. Conditioning

9.1 Prior to testing, condition the cable specimen for at least 3 h in an atmosphere at a temperature of $23 \pm 5^\circ\text{C}$ ($73 \pm 10^\circ\text{F}$) with a relative humidity of less than 55 %. Test cables within 10 min of removal from such conditions if test room conditions differ from the preceding conditions.

10. Procedure

10.1 Do not carry out the test if the temperature of the chamber wall is below 5°C (41°F) or above 30°C (86°F).

10.2 Establish an initial volumetric flow rate of $0.65 \pm 0.05 \text{ m}^3 \text{ s}^{-1}$ ($23 \pm 2 \text{ ft}^3 \text{ s}^{-1}$) through the duct. See Annex A1 for the measuring techniques and for the equation to calculate volumetric flow rate of the gas in the duct (Eq A1.1). Record the volumetric flow rate as a function of time, starting 1 min prior to the test. Do not change the flow rate once the initial flow rate is established.

10.3 Position the prepared cable tray vertically inside the enclosure with the open front of the cable tray facing the front of the enclosure. Fix the cable tray firmly in position.

10.4 Start all recording and measuring devices before starting the ignition burner, to ensure they are stabilized.

10.5 Ignite the gas mixture in the burner and adjust the gas flows to the values specified in 7.67.10 and 7.67.11. Position the burner as indicated in 7.67.3 (Protocol A) or 7.67.4 (Protocol B). See Fig.-6 8 for the relative positions of the cable tray and burner in the enclosure.

10.6 Allow the burner flame to impinge on the cable specimen for a continuous period of 20 min.

10.7 At 20 min, extinguish the burner flame, but allow the cable fire (if any) to burn out.

10.8 Optionally, photograph or video record before and during the test. Include a clock, giving time to the nearest 1 s, in all photographic records.

10.9 During the test, record the following events and the time interval when they occur (beginning and end).

10.9.1 Ignition of the specimen,

10.9.2 Position of flame front,

10.9.3 Melting and dripping,

10.9.4 Occurrence of pool fire under the specimen,

10.9.5 General description of the burning behavior,

10.9.6 Time of afterburn, after extinguishing the propane, and

10.9.7 Any other event of special interest.

NOTE 3—It is possible for ignition of the cables to occur almost immediately after ignition of the burner. However, time to ignition of the cables is occasionally difficult to determine.

10.10 Conduct the procedure in duplicate. Conduct each procedure (burn) on untested cable specimens.

10.11 *Evaluation of Damage:*

10.11.1 After burning has ceased, let the cables and tray cool to room temperature, then wipe the cables clean with a cloth and determine cable damage.

10.11.1.1 *Protocol A*—Determine the maximum height of cable damage by measuring the blistering, char, and other damage upward from the bottom of the vertical tray.

10.11.1.2 *Protocol B*—Determine the maximum height of cable damage by measuring the blistering, char, and other damage from the lower edge of the burner face.

10.11.2 Determine the limit of charring by pressing against the cable surface with a sharp object. Where the surface of the cable (outer jacket, if any) changes from a resilient surface to a brittle (crumbling) surface determines the limit of charring. Include distortion of the outer surface of the cable, such as blistering or melting, immediately above the char, in the damage measurement.

10.11.3 Record the cable damage (char) to the nearest 25 mm (1 in.). On cable constructions that do not have charring, define the limit for the affected portion as the point where the overall diameter is visibly reduced or increased.

10.11.4 For engineering information, record damage such as blistering, or softening/melting of combustible material above the char.

10.12 Heat Release Measurements:

10.12.1 Make continuous measurements of heat release by measuring oxygen concentration and mass flow rate in the exhaust duct.

10.12.2 From these measurements and the equations in Annex-A4 A5 determine the rates and amounts of heat release. These values together with the visual recordings constitute the results from the test.

11. Calculation

11.1 Considerations for heat release measurements are presented in Appendix X2. The corresponding equations for heat release calculations are presented in Annex-A4 A5. The testing laboratory shall choose which of the equations in Annex-A4 A5 it wishes to use for the heat release calculations. Equations for smoke release calculations are presented in Annex A6.

12. Report

12.1 Report the following information:

12.1.1 *Descriptive Information:*

12.1.1.1 Name and address of the testing laboratory,

12.1.1.2 Inside dimensions of enclosure,

12.1.1.3 Date and identification number of the report,

12.1.1.4 Methods of sampling for selecting the test specimens,

12.1.1.5 Name of product manufacturer or supplier, if known,

12.1.1.6 Name or other identification marks and description of the product,

12.1.1.7 Density, or weight per unit surface, and total mass, thickness of the main components in the product (including jacket and insulation), and mass of combustible portion of product, if known,

12.1.1.8 Description of the samples,

12.1.1.9 Conditioning of the specimens,

12.1.1.10 Date of test, and

12.1.1.11 Test number, Protocol (A or B) and any special remarks.

12.1.2 *Test Results:*

12.1.3 *Table of Mandatory Numerical Results Containing:*

12.1.3.1 Maximum char damage, m,

12.1.3.2 Peak rate of heat release, kW, and the appropriate time at which it occurred,

12.1.3.3 Total heat released, MJ,

12.1.3.4 Time of afterburn, s,

12.1.3.5 Peak rate of smoke release, $m^2 s^{-1}$, and the appropriate time at which it occurred,

12.1.3.6 Total smoke released, m^2 ,

12.1.3.7 Total mass loss, g,

12.1.3.68 Percentage of mass loss, %,

12.1.3.79 Peak flame height, m, and the appropriate time at which it occurs,

12.1.3.810 Peak mass loss rate, $g s^{-1}$,

12.1.3.911 Average mass loss rate, over the entire burn, $g s^{-1}$, and

12.1.3.102 Equation used to calculate rate of heat release.

12.1.4 *Additional Table of Mandatory Numerical Results Containing:*

12.1.4.1 Total heat release data after every minute,

12.1.4.2 Rate of heat release data after every minute,

12.1.4.3 Total smoke release data after every minute,

12.1.4.4 Rate of smoke release data after every minute,

12.1.4.5 Mass loss rate data after every minute, and

12.1.4.46 Volumetric flow rate after every minute.

12.1.5 *Mandatory Graphical Results :*

12.1.5.1 Plot of rate of heat release versus time,

12.1.5.2 Plot of total heat released versus ~~time, and time,~~

12.1.5.3 Plot of rate of smoke release versus time,

12.1.5.4 Plot of total smoke released versus time, and

12.1.5.5 Plot of mass loss rate versus time.

12.1.6 *Descriptive Results:*

12.1.6.1 Photographs or videotape, if available, of the fire development, and

12.1.6.2 All available information listed in 10.9.

13. Precision and Bias

13.1 *Precision*—The precision of this test method has not been determined. Results of a planned interlaboratory test series will be included when available.

13.2 *Bias*—The true value of fire performance of electrical or optical fiber cables can only be defined in terms of a test method. Within this limitation, this test method has no known bias and can be accepted as a reference method.

14. Keywords

14.1 cable; cable tray; calorimetry; carbon dioxide; carbon monoxide; char; electrical cable; electrical insulation; fire; fire-test response; flame; heat release; heat release rate; ignition; optical density; optical fiber cable; oxygen consumption calorimetry; smoke obscuration; smoke release; toxic gases

ANNEXES

(Mandatory Information)

A1. VOLUMETRIC FLOW RATE

A1.1 One technique for measuring the flow is a bidirectional probe located at the center line of the duct. The probe shown in Fig. 2 consists of a stainless steel cylinder, 44 mm (1.75 in.) long and with an inner diameter of 22 mm (0.875 in.). The cylinder has a solid diaphragm in the center, dividing it into two chambers. The pressure difference between the two chambers is measured by a differential pressure transducer.

A1.2 Use a differential pressure transducer with an accuracy of at least ± 0.25 Pa (0.001 in. of water) and of the capacitance type. A suitable range of measurement is 0 to 150 Pa.

A1.3 Place one thermocouple 152 ± 25 mm (6 ± 1 in.) upstream from the bidirectional probe. Use an Inconel sheathed 24 AWG (0.51 mm (0.020 in.) in diameter) thermocouple, type K Chromel-Alumel. Place the thermocouple wire, within 13 mm (0.5 in.) of the bead, along expected isotherms to minimize conduction errors. Use an insulation between the Chromel and Alumel wires that is stable to at least 1100°C (2000°F). Ensure that the thermocouple does not disturb the flow pattern around the bidirectional probe.

A1.4 The volumetric flow rate, in $\text{m}^3 \text{s}^{-1}$, in the duct under standard conditions is calculated in accordance with Eq A1.1 as follows (symbols in ~~Annex A4.3~~ A5.3):

$$V_s = C_v k_f A \sqrt{\left[\frac{2\Delta p}{\rho_o} \frac{T_o}{T} \right]} = 20.1 k_f A \sqrt{\left[\frac{\Delta p}{T} \right]} \quad (\text{A1.1})$$

A2. DESIGN OF EXHAUST SYSTEM

A2.1 Hood and Exhaust Duct, Recommended Design:

A2.1.1 Collect the combustion gases from the burning specimen by means of a hood. A system is described in A2.1.2 which was tested in practice and proven to fulfill the specifications given in this test method.

A2.1.2 The hood is located above the room. The bottom dimensions of the hood are 2.44 by 2.44 m (96 in. by 96 in.) (see Fig. 1). The hood feeds into a cubical box/plenum having 0.910 ± 0.025 m (36 ± 1 in.) as the dimension of each side. A maximum height of 1.80 ± 0.1 m (71 ± 4 in.), to satisfy building constraints, is acceptable. Underneath the hood, locate a baffle plate approximately 0.6 by 0.6 m (2 by 2 ft) (see Fig. 1), to increase mixing of the combustion gases. Design and manufacture the hood and its attachment to the chamber so that no leakage exists.

A2.1.3 If a laser beam is used, a suitable way of mounting the beam together with the gas sampling probes is shown in Fig. A2.1.

A2.1.4 Connect an exhaust duct with the plenum chamber. The inner diameter of the exhaust duct is 410 ± 25 mm (16 ± 1 in.). To facilitate flow measurements, locate guide vanes, if needed, at both ends of the exhaust duct. Alternatively, make the rectilinear part of the exhaust duct long enough that a fully-developed flow profile is established at the point of measurement. Connect the exhaust duct to an evacuation system.

A2.1.45 Design the capacity of the evacuation system so as to exhaust minimally all combustion gases leaving the specimen. This requires an exhaust capacity of at least 2.7 kg s^{-1} (about $8000 \text{ m}^3 \text{ h}^{-1}$ at standard atmospheric conditions) corresponding to a driving under pressure of about 2 kPa at the end of the duct. Provide a means to control the exhaust flow from 0.5 kg s^{-1} up to maximum flow as stated previously during the test process. Ensure that the measurement system has sufficient sensitivity for measurement of low rates of heat release. Use mixing vanes in the duct if concentration gradients are found to exist. An alternative system for dealing with concentration gradients is acceptable if it is shown to produce equivalent results.

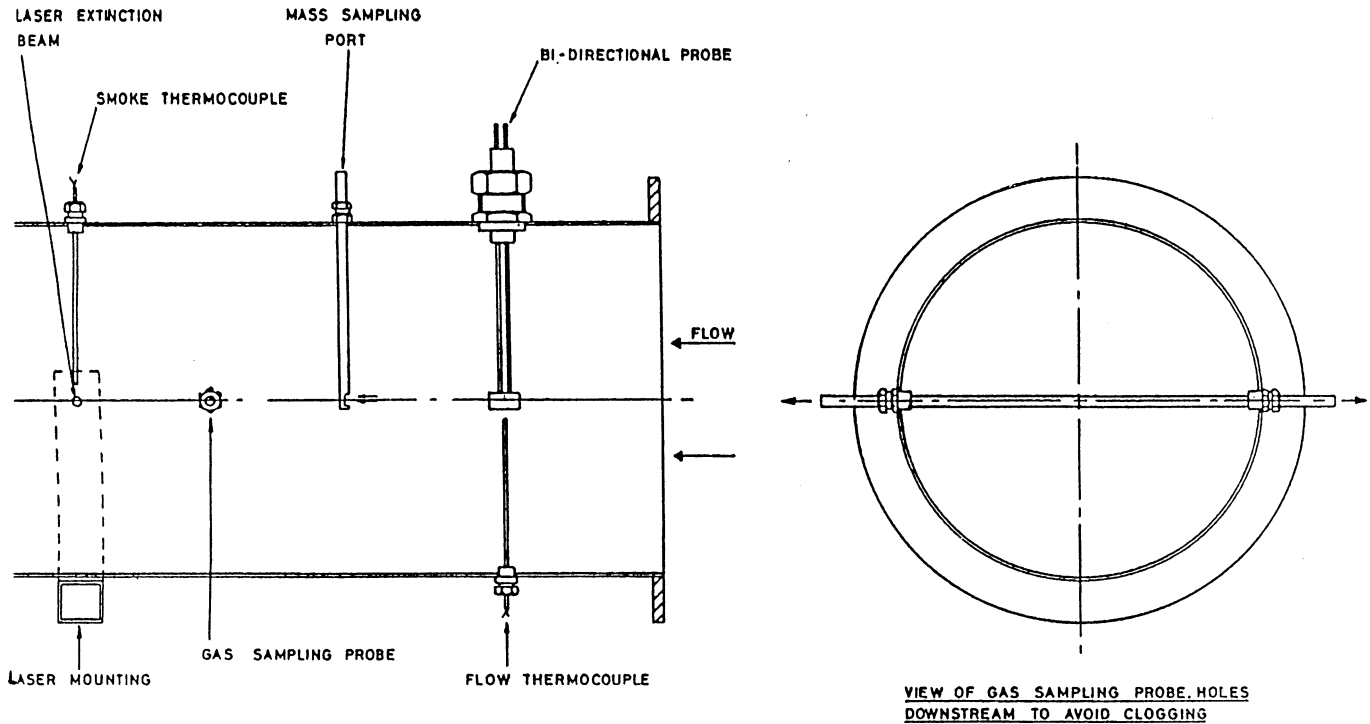

FIG. A2.1 Means of Mounting Laser Beam and Sampling Probe

A2.1.56 An alternative exhaust system design is acceptable if it is shown to produce equivalent results. Equivalency is demonstrated by meeting the calibration requirements of Section 8. Exhaust system designs based on natural convection are unacceptable.

A3. INSTRUMENTATION FOR SMOKE MEASUREMENT IN EXHAUST DUCT

A3.1 Volume Flow:

A3.1.1 One technique for measuring the flow is a bidirectional probe located at the centerline of the duct. The probe shown in Fig. 2 consists of a stainless steel cylinder, 44 mm (1.75 in.) long and with an inner diameter of 22 mm (0.875 in.). The cylinder has a solid diaphragm in the center, dividing it into two chambers. The pressure difference between the two chambers is measured by a differential pressure transducer.

A3.1.2 Use a differential pressure transducer with an accuracy of at least ± 0.25 Pa (0.001 in.) of water and of the capacitance type. A suitable range of measurement is 0 to 150 Pa.

A3.1.3 Place one thermocouple 152 ± 25 mm (6 ± 1 in.) upstream from the bidirectional probe. Use an Inconel sheathed 24 AWG gage (0.51 mm (0.020 in.) in diameter) thermocouple, type K Chromel-Alumel. Place the thermocouple wire, within 13 mm (0.5 in.) of the bead, along expected isotherms to minimize conduction errors. Use an insulation between the Chromel and Alumel wires that is stable to at least 1100°C (2000°F). Ensure that the thermocouple does not disturb the flow pattern around the bidirectional probe.

A3.2 Smoke Obscuration:

A3.2.1 One suitable light measuring system based on white light has the following components: a lamp, plano convex lenses, an aperture, a photocell and an appropriate power supply. Mount lenses, lamp and photocell inside two housings located on the exhaust duct, diametrically opposite each other. It has been found that a system consisting solely of a white light and a photocell, along the exhaust duct, across from each other and at an angle to the vertical, is satisfactory in some cases.

A3.2.1.1 Use a lamp of the incandescent filament type, which operates at a color temperature of 2900 ± 100 K. Supply the lamp with stabilized direct current, stable within ± 0.2 % (including temperature, short term and long term stability). Center the resultant light beam on the photocell.

A3.2.1.2 Select the lens system such that the lens L_2 , according to Fig. 3, has a diameter, d , chosen with regard to the focal length, f , of L_2 so that $d/f \neq 0.04$.

A3.2.1.3 Place the aperture in the focus of lens L_2 according to Fig. 3.

A3.2.1.4 Use a detector with a spectrally distributed response according to the CIE photopic curve and linear within 5 % over

an output range of at least 3.5 decades. Check this linearity over the entire range of the instrument periodically with calibrated optical filters.

A3.2.2 The system described as follows is an example of a light measuring system that has been found satisfactory:

(1) *Lenses*—Plano convex: diameter 40 mm, focal length 50 mm,

(2) *Lamp*—Osram Halo Stars: 64410: 6 V, 10 W, or equivalent,

(3) *Photocell*—United Detector Technology: PIN 10 AP, or equivalent, and

(4) *Voltage Supply*—Gresham Lion Ltd: Model G × 012, or equivalent.

A3.2.2.1 Design a system that is easily purged against soot deposits. The use of holes in the periphery of the two housings is a means of achieving this objective.

A3.2.3 An acceptable alternate system for measurements of smoke obscuration uses a laser beam. A 0.5 to 2.0 mW helium-neon laser beam is projected across the exhaust duct. Couple the two halves of the device rigidly together (see Fig. 4).¹²

¹² One satisfactory

¹² An example of a suitable system is a burner supplied that manufactured by American Gas Furnace Company, Inc., of Elizabeth, NJ, Catalog No. 10L 11-55, with an air/gas Venturi mixer, Catalog No. 14-18. Equivalent systems are probably available: Fire Testing Technology Ltd., P.O. Box 116, East Grinstead, West Sussex, RH19 2YE, UK, who provide detailed construction guidance.

A4. MASS FLOW RATE MEASUREMENTS

A34.1 There are primarily two techniques used to measure mass flow rate in the exhaust duct of full-scale fire tests.

A34.2 The first technique measures mass flow rate by means of the pressure drop across, and temperature at, an orifice plate. If the test is conducted within a narrow range of conditions, the orifice plate coefficient, C , is approximately constant. It is possible to determine its value with a gas burner calibration. However, if flow rates are varied during a test or if temperature changes are considerable, take into account the effect on C of the Reynolds number and of pressure at the downstream side of the orifice plate. Information on such corrections and on various design options (for example, location of the pressure taps) is found in Ref. ~~(1)~~**(6)**.

~~A3.3~~

A4.3 The other technique is to measure velocity at one point in the duct, usually along the centerline. Calculate the flow rate using a measured velocity profile in the duct. This velocity profile is obtained by measuring velocity at a sufficient number of representative points over the diameter or cross section of the duct prior to any fire tests. Detailed procedures to obtain this profile are described in Ref. ~~(27)~~. Usually, conditions in full scale fire tests are such that the flow in the duct is turbulent, resulting in a shape factor k_c (ratio of the average velocity to the velocity along the centerline) close to 1.

A34.4 Due to considerable soot production in many fires, pitot tubes are generally not useful because of clogging of the holes. This is unlikely to cause a problem in a test of a single item. Thus, if pitot tubes are used, they must be completely cleaned after each test. In order to deal with this problem, a more robust bidirectional probe was designed by McCaffrey and Heskestad ~~(38)~~. This involves measuring the differential pressure across the probe and the centerline velocity, and is valid in the range of Reynolds numbers, Re :

$$40 < Re < 3800$$

In many full scale fire test applications, duct diameter and flow rate are such that the Reynolds number is:

$$Re > 3800$$

In this case $f(Re)$ is taken as a constant (1.08), which greatly simplifies the calculations. Further details of this and of all other calculations discussed in this Annex are found in a paper by Janssens ~~(4)(9)~~. For additional details see ISO 9705.

A34.4.1 In the system described, the Reynolds number is always greater than 3800, so that:

$$f(Re) = 1.08 \tag{A4.1}$$

~~A34.5 Mass Flow Rate Measurement Equations (see symbols in Annex A4.3):~~ A4.3:

A34.5.1 *Pressure Drop Method* (Eq A34.2):

$$m_e = C \times \sqrt{\left[\frac{\Delta p}{T_e} \right]} \tag{A4.2}$$

A34.5.2 *Velocity Method* (Eq A34.3):

$$m_e = 26.54 \times \frac{A \times k_c}{f(Re)} \times \sqrt{\left[\frac{\Delta P}{T_e} \right]} \quad (\text{A4.3})$$

A45. HEAT RELEASE MEASUREMENT EQUATIONS

A45.1 *Rate of Heat Release*—Considerations for heat release measurements are given in Appendix X2; symbols in A45.3.

A45.1.1 *Case 1: (Only O₂ concentration measurements are used)*—Calculate the mass flow rate in accordance with the equations in A34.5 (A34.1 and A34.2) and the oxygen depletion factor in accordance with Eq A45.1:

$$\phi = \frac{X_{O_2}^{A^0} - X_{O_2}^A}{[1 - X_{O_2}^A] \times X_{O_2}^{A^0}} \quad (\text{A5.1})$$

The rate of heat release is then calculated according to Eq A45.2:

$$\dot{q} = E \times \frac{M_{O_2}}{M_a} \times \frac{\phi}{1 + \phi \times (\alpha - 1)} \times m_e \times X_{O_2}^{A^0} \quad (\text{A5.2})$$

If only O₂ is measured, Eq A45.2 can be converted into Eq A45.3:

$$\begin{aligned} \dot{q} &= E \times 1.10 \times C \sqrt{\left[\frac{\Delta p}{T_e} \right]} \times \left[\frac{(X_{O_2}^{A^0} - X_{O_2}^A)}{1.105 - (1.5 \times X_{O_2}^A)} \right] \\ \dot{q} &= E \times 1.10 \times C \sqrt{\left[\frac{\Delta p}{T_e} \right]} \times \left[\frac{(X_{O_2}^{A^0} - X_{O_2}^A)}{1.105 - (1.5 \times X_{O_2}^A)} \right] \end{aligned} \quad (\text{A5.3})$$

A45.1.2 *Case 2: (Only O₂ and CO₂ measurements are used)*—Calculate the mass flow rate in accordance with the equations in A34.5 (A34.1 and A34.2) and the oxygen depletion factor in accordance with Eq A45.4:

$$\phi = \frac{X_{O_2}^{A^0} \times [1 - X_{CO_2}^A] - X_{O_2}^A \times [1 - X_{CO_2}^{A^0}]}{X_{O_2}^{A^0} \times [1 - X_{O_2}^A - X_{CO_2}^A]} \quad (\text{A5.4})$$

and the rate of heat release according to the same equation in A45.1.1 (Eq A45.2).

A45.1.3 *Case 3: (O₂ and CO₂ and CO measurements are used)*—Calculate the mass flow rate in accordance with the equations in A34.5 (Eq A34.2 and Eq A34.3) and the oxygen depletion factor in accordance with Eq A45.5:

$$\phi = \frac{(X_{O_2}^{A^0} \times [1 - X_{CO_2}^A - X_{CO}^A]) - (X_{O_2}^A \times [1 - X_{CO_2}^{A^0}])}{X_{O_2}^{A^0} \times [1 - X_{O_2}^A - X_{CO_2}^A - X_{CO}^A]} \quad (\text{A5.5})$$

Then calculate the rate of heat release in accordance with Eq A45.6:

$$\begin{aligned} \dot{q} &= \left[E \times \phi - [E_{CO} - E] \times \frac{1 - \phi}{2} \times \frac{X_{CO}^A}{X_{O_2}^A} \right] \\ &\times \frac{M_{O_2}}{M_a} \times \frac{m_e}{1 + \phi \times (\alpha - 1)} \times X_{O_2}^{A^0} \end{aligned} \quad (\text{A5.6})$$

A45.2 *Heat Release Measurement for Calibration Purposes:*

A45.2.1 Use Eq A45.7 for heat release measurements during calibration, which has the correct values for pure propane as a fuel.

$$\dot{q} = E \times 1.10 \times C \sqrt{\left[\frac{\Delta p}{T_e} \right]} \times \left[\frac{(X_{O_2}^{A^0} - X_{O_2}^A)}{1.084 - (1.5 \times X_{O_2}^A)} \right] \quad (\text{A5.7})$$

A45.3 *Symbols:*

- A = cross-sectional area of the duct at the location of the probe, m²,
 C = orifice plate coefficient, kg^{1/2} m^{1/2} K^{1/2},

C_v	= a suitable calibration factor for bidirectional probes based upon air velocities in excess of 3.0 m s^{-1} (10 ft s^{-1}) in a 0.4 m (16 in.) duct, dimensionless,
E	= net heat released per unit mass of oxygen consumed (13.1 MJ/kg O_2),
E_{CO}	= net heat released per unit mass of oxygen consumed, for CO (17.6 MJ/kg O_2),
$f(Re)$	= Reynolds number correction,
k_c	= velocity profile shape factor, nondimensional,
k_t	= ratio of the average duct gas mass flow rate per unit area, as determined by measuring the velocity and temperature profiles across the stack, to the duct mass gas flow rate per unit area, as determined by measuring the velocity and temperature at the centerline where the bidirectional probe is located during the test,
\dot{m}_e	= mass flow rate in exhaust duct, kg s^{-1} ,
M_a	= molecular weight of incoming and exhaust air (29 kg/kmol),
M_{CO}	= molecular weight of carbon monoxide (28 kg/kmol),
M_{CO_2}	= molecular weight of carbon dioxide (44 kg/kmol),
$M_{\text{H}_2\text{O}}$	= molecular weight of water (18 kg/kmol),
M_{N_2}	= molecular weight of nitrogen (28 kg/kmol),
M_{O_2}	= molecular weight of oxygen (32 kg/kmol),
Δp	= pressure drop across the orifice plate, Pa,
ΔP	= differential pressure measured across the bidirectional probe, Pa,
\dot{q}	= rate of heat release, kW,
T	= duct gas temperature, K,
T_c	= gas temperature at the orifice plate, K,
T_o	= reference temperature for volumetric flow rate, K,
V_e	= volumetric flow rate in the exhaust duct, $\text{m}^3 \text{ s}^{-1}$,
X_{CO}^A	= measured mole fraction of CO in exhaust flow, nondimensional,
$X_{\text{CO}_2}^A$	= measured mole fraction of CO_2 in exhaust flow, nondimensional,
$X_{\text{CO}_2}^I$	= measured mole fraction of CO_2 in incoming air, nondimensional,
$X_{\text{O}_2}^A$	= measured mole fraction of O_2 in exhaust flow, nondimensional,
$X_{\text{O}_2}^I$	= measured mole fraction of O_2 in incoming air, nondimensional,
α	= combustion expansion factor (nondimensional; normally a value of 1.105, except for pure propane, where the value is 1.084, to be used for calibration), and
ρ_o	= density of air at the reference temperature T_o (kg m^{-3}).

A6. SMOKE MEASUREMENT EQUATIONS

A6.1 Calculate optical density by using Eq A6.1 and extinction coefficient by using Eq A6.2:

$$\text{Optical density (OD): } OD = \log [I_o/I] \quad (\text{A6.1})$$

$$\text{Extinction coefficient (k): } k = (1/L_p) \times \ln (I_o/I) \quad (\text{A6.2})$$

where:

- I = the light intensity for a parallel light beam having traversed a certain length of smoky environment and reaching photodetector
- I_o = the light intensity for a beam of parallel light rays, measured in a smoke free environment, with a detector having the same spectral sensitivity as the human eye and reaching the photodetector, and
- L_p = the light path length of the beam through a smoky environment.

A6.2 The volumetric flow rate is calculated as the product of the mass flow rate and the density of air, at the corresponding temperature. Thus, both the volumetric flow and the density of air must undergo temperature corrections. The volumetric duct flow rate (\dot{V}) is adjusted by a ratio of temperatures, because it is measured in the exhaust duct (\dot{V}_e , corresponding temperature: T_e), but required at the temperature near the photodetector (\dot{V}_i , corresponding temperature: T_i), as shown in Eq A6.3:

$$\dot{V}_i = \dot{V}_e \times (T_e/T_i) \quad (\text{A6.3})$$

A6.3 The density of air is adjusted between the literature value, measured at 273.15 K, and the value at the temperature in the exhaust duct, as shown in Eq A6.4:

$$\rho = \rho_o \times 273.15/T_e \quad (\text{A6.4})$$

A6.4 Then, the final equation for the volumetric flow rate becomes Eq A6.5:

$$\dot{V}_i = \dot{m}_e \times \rho_o \times T_o/273.15 \quad (\text{A6.5})$$

A6.5 Rate of smoke release (RSR) is defined by Eq A6.6:

$$RSR = [\dot{V}_s \times k] \quad (A6.6)$$

A6.6 Total smoke released (TSR) is defined by Eq A6.7:

$$TSR = \int RSR dt \quad (A6.7)$$

A6.7 Average optical density (Av OD) is defined by Eq A6.8:

$$Av OD = \frac{\sum OD_{scans}}{\sum scans} \quad (A6.8)$$

A6.8 Measurement of Smoke Obscuration Parameters:

A6.8.1 The optical density of smoke is dependent upon the volumetric flow rate in the duct, and is, thus, not an absolute measurement. It is recommended that smoke release rate and its integrated value (total smoke released) are more adequate measurement values.

A6.8.2 In at least one document, UL 1685, rate of smoke release is defined in terms of optical density instead of being defined in terms of the more usual extinction coefficient. The difference between the two resulting values of rate of smoke release is a constant factor: the natural logarithm of 10, that is, 2.3026, with the numbers based on optical density being lower.

APPENDIXES

(Nonmandatory Information)

X1. COMMENTARY

X1.1 Introduction

X1.1.1 This commentary is provided to give some insight into the development of the test method and to describe a rationale for various features used, both in the mandatory and the optional sections of this test method.

X1.2 Measurements

X1.2.1 *Smoke Obscuration:*

X1.2.1.1 The visibility in a fire atmosphere will adversely affect the ability of victims to escape and the ability of fire brigades to fight the fire.

X1.2.2 *Rate of Heat Release:*

X1.2.2.1 The rate of heat release is one of the most important variables, possibly even the single most important variable, in determining the hazard from a fire ~~(5-9)~~**(10-14)**. In particular, the rate of heat release is a measure of the intensity of the fire. The rate of heat release and the amount of heat released will determine the extent to which other materials, products or assemblies in the fire compartment may ignite and spread the fire further. The amount of smoke generated is usually a direct function of the heat release rate.

X1.2.2.2 The rate of heat release can be determined by measuring the oxygen depletion in a fire atmosphere ~~(10-12)~~**(15-17)**. Oxygen concentration measurement devices, of the paramagnetic type, are now sufficiently precise to measure the small differences in oxygen concentration needed for determining rate of heat release.

X1.2.3 *Smoke Toxicity:*

X1.2.3.1 The victims of a fire are often overcome by the toxicity of the atmosphere. This is determined by the concentration of smoke (see Terminology E 176) and by the toxicity of its individual components. The overall amount of smoke generated can be measured by means of the mass loss rate, which is equivalent to the rate of smoke generation. The single most important individual toxicant in a fire atmosphere is carbon monoxide, which is present in all fires, together with carbon dioxide and water ~~(13, 14)~~**(18, 19)**. Some other gases, such as acrolein, hydrogen cyanide, and hydrogen chloride, are also frequently present and may thus also contribute to the toxicity of the fire atmosphere. Appendix X2 contains details on instrumentation, measurements, and results to report for optional gas concentration measurements. Details of smoke obscuration measurements are found in Test Method D 5424.

X1.3 Electrical Cables

X1.3.1 Traditional fire tests on electrical cables, such as those in the standards described as the basis of this test procedure, have focussed on flame spread. This fire-test-response standard goes beyond that by also measuring heat release and mass loss.

X1.3.2 The determination of cable damage by measurement of maximum char length is not a totally adequate way of determining cable flame spread properties, but it gives a simple indication of quality of fire performance of the cable.

X1.3.3 Several examples exist of experiments carried out measuring heat release of cables using this test design, such as those in Refs. ~~(15-19)~~**(1, 2, 3, 20, 22)**.

X1.3.4 The National Electrical Code has adopted a category of cables with a limited smoke (or -LS) designation, which are listed after having undergone testing for flame propagation and smoke release according to UL 1685.

X1.3.5 Optional measurements that are possible with this test method are ~~smoke release (Test Method D 5424)~~ and the rates and amounts of carbon oxide release. These measurements allow a more complete set of fire-test-response characteristics to be obtained from a single specimen with the same fire model, which is then useful in assessing the fire hazard.

X1.4 Test Facility

X1.4.1 It has been shown that equivalent values of the rate of heat release of upholstered furniture are obtained in the standard ASTM room (2.44 by 3.66 m by 2.44 m, or 8 by 12 ft by 8 ft high) (also used for room-corner tests in NFPA 265 and NFPA 286), in the alternate room (namely Test Configuration B) described in Test Method E 1537 (3.705 by 3.66 m by 2.44 m high, or 10 by 12 ft by 8 ft high) and in a furniture calorimeter (such as those described in Practice E 2067), unless the heat release rate exceeds 600 kW (21). This suggests that, if heat or smoke release rate is needed to ensure all laboratories use the same means only information sought, the size of protecting the load cell, and help test facility may not be critical. However, further work is required to improve precision of results. It confirm these results for cable tests.

X1.4.2 It has also been shown that some materials that have been placed underneath the burning sample very similar results are obtained from two different test facilities, in large scale fire tests can cause significant differences in the extent to which fire, flames both heat and smoke continue being released by the material release, for many electrical cables (1, 3, 20). This is an important result, because it suggests, too, that has fallen off the burning sample. In exact dimensions and layout of the facility are not as crucial as was at least one k point thought. This also needs further confirmation.

X1.4.3 It has been shown that the heat and smoke release varied by over half the amount as measured with a function of laser beam and with a white light system are equivalent, unless the material used beneath the sample.

X2. CONSIDERATIONS FOR HEAT RELEASE MEASUREMENTS scanning time is very long (>5 s). This applies to both small scale instruments (4, 5) and full scale cable tray testing facilities (1-3).

X1.5 Platform

X1.5.1 The platform described in 7.8.7 is needed to ensure all laboratories use the same means of protecting the load cell, and help to improve precision of results. It has been shown that some materials that have been placed underneath the burning sample in large scale fire tests can cause significant differences in the extent to which fire, flames and smoke continue being released by the material that has fallen off the burning sample. In at least one known case the heat and smoke release varied by over half the amount as a function of the material used beneath the sample.

X2. CONSIDERATIONS FOR HEAT RELEASE MEASUREMENTS

X2.1 Measurement of Rate of Heat Release by Oxygen Consumption

X2.1.1 *Introduction*— In 1917, Thornton (203) showed that for a large number of organic fuels, a more or less constant net amount of heat is released per unit of oxygen consumed for complete combustion. Huggett (214) obtained an average value for this constant of 13.1 MJ/kg of O₂. This value may be used for practical applications and is accurate, with very few exceptions, to within ± 5 %.

X2.1.2 Thornton's rule implies that it is sufficient to measure the oxygen consumed in a combustion system in order to determine the net heat released. This is particularly useful for full-scale fire test applications. For example, for compartment fires, the oxygen consumption technique is much more accurate and easier to implement than methods based on measuring all the terms in a heat balance of the compartment.

X2.1.3 Perhaps the first application of the O₂ consumption principle in fire research was by Parker (225) using Test Method E 84 (tunnel test). Later, Sensenig (236) applied it to an intermediate scale room test. During the late seventies and early eighties, the National Institute for Standards and Technology (NIST, formerly NBS) refined the O₂ consumption technique. A paper by Parker (247) gives equations to calculate rate of heat release by O₂ consumption for various applications. The technique is now used extensively in many laboratories all over the world, both in bench-scale (258) and full-scale (5, 26)(10, 29) fire test applications.

X2.1.4 The objective of this appendix is to provide a comprehensive set of equations and guidelines to determine the rate of heat release in full-scale fire tests based on the O₂ consumption principle. The approach followed here is somewhat different from Parker (258) as the emphasis is on full-scale fire test applications and it avoids the use of volumetric flow rates. Volumetric flow rates require specification of temperature and pressure. Various investigators have used different combinations of reference pressure and temperature. This leads to confusion which is greatly eliminated by the use of mass flow rates instead.

X2.1.5 The basic requirement is to collect and remove all combustion products in a hood and through an exhaust duct. At a distance downstream of the hood sufficient for adequate mixing, measure both flow rate and composition of the gases. It is assumed

that it is not possible to measure the air flow rate into the system as this is generally the case for full-scale fire tests. The differences in treatment and equations used are mainly due to the extent to which gas analysis is made. Measure at least O_2 , but, if additional instrumentation is available, heat release rate measurements are more accurate by measuring CO_2 and CO as well.

X2.1.6 It needs to be emphasized that the analysis is approximate. The following list describes the main simplifying assumptions made:

- (1) The amount of energy released by complete combustion per unit of oxygen consumed is taken as: $E = 13.1$ MJ/kg of O_2 .
- (2) All gases are considered to behave as ideal gases. In other words, one mole of any gas is assumed to occupy a constant volume at the same pressure and temperature.
- (3) Incoming air consists of O_2 , CO_2 , H_2O , and N_2 . All “inert” gases, which do not take part in the combustion reactions, are lumped into the nitrogen.
- (4) O_2 , CO_2 , and CO are measured on a dry basis. In other words, water vapor is removed from the sample before gas analysis measurements are made.

X2.1.7 In the analysis to follow, initial emphasis is placed on the flow rate measurement. Equations to calculate flow rate are generally applicable, irrespective of the configuration of the gas analysis system. In subsequent sections, distinction is made between various gas analyzer combinations.

X2.2 Rate of Heat Release if Only Oxygen Concentration Measurements are Used

X2.2.1 In this case all water vapor and CO_2 are eliminated by the use of appropriate filtering media. This leads to the assumption that the sample gas only consists of O_2 and N_2 . This is approximately true provided CO production is negligible. As the composition of the incoming air does not normally change during a test, and as the temperatures in building fires are usually not high enough to generate noticeable amounts of nitrogen oxides by nitrogen fixation, the mole fraction of O_2 in the air as measured by the analyzer prior to a test can be written on the basis of O_2 and N_2 exclusively. The mole fraction of O_2 in the exhaust gases, as measured by the oxygen analyzer, can be written likewise. As nitrogen is conserved and does not participate in the combustion reactions, the equations are derived on the basis of its conservation.

X2.2.2 In this case the rate of heat released (in kW) is calculated as a function of the heat released per unit of oxygen consumed (E , 13.1 MJ/kg of O_2), the ratio of the molecular weight of oxygen (M_1 , 32.0 kg/kmol) and the molecular weight of the incoming air (M_2 , generally taken as 28.97 kg/kmol), the mass flow rate of the incoming air (in $kg\ s^{-1}$) and the humidity of the incoming air. The flow rate measured is that of the smoke within the exhaust duct and not that of the incoming air. In order to find a relation between the two it is necessary to define the oxygen depletion factor. The oxygen depletion factor is the fraction of the incoming air which is fully depleted of its oxygen. It has been demonstrated (see Appendix in Test Method E 1354), that the rate of heat release is a function of E , M_1 , M_2 , and the oxygen depletion factor, plus the expansion factor. The expansion factor must be assigned: a recommended average value is 1.105. For calibration with propane, the correct value is 1.084. The value for carbon in dry air is 1.0 and for hydrogen is 1.21.

X2.2.3 The resulting equation is expected to be accurate to within $\pm 5\%$ provided combustion is complete. In other words, all carbon is converted to CO_2 . Errors will be larger if CO or soot production is considerable or if a significant amount of the combustion products are other than CO_2 and H_2O . It is unlikely that these errors will be of concern for a single item of test.

X2.3 Rate of Heat Release if Oxygen and Carbon Dioxide Concentration Measurements are Used

X2.3.1 This case is similar to that covered in the former section. We assume now that only water vapor is trapped before the sample reaches the gas analyzers. Again, the equations are derived on the basis of conservation of nitrogen. The mole fraction of CO_2 in the incoming air is taken to be 440 ppm. Again the equation for the rate of heat release is accurate to within $\pm 5\%$ provided combustion is complete, in other words if all carbon converted to CO_2 .

X2.4 Rate of Heat Release Measurement if Oxygen, Carbon Dioxide and Carbon Monoxide are Being Measured

X2.4.1 This case reverts to that covered in Section X2.3 if CO production is negligible. Taking CO into account, however, changes the equations.

X2.5 Conclusions

X2.5.1 Depending on the configuration of gas analyzers and the type of flow rate measurement, use one of the following procedures to calculate rate of heat release:

X2.5.2 *Case 1: Only O_2 is measured:*

- (1) Calculate the mass flow rate of the exhaust gases,
- (2) Obtain the moisture content of the incoming air,
- (3) Calculate the oxygen depletion factor, and
- (4) Calculate the rate of heat release.

X2.5.3 *Case 2: Both O_2 and CO_2 are measured:*

- (1) Calculate the mass flow rate of the exhaust gases as in X2.5.2,
- (2) Obtain the moisture content of the incoming air as in X2.5.2,
- (3) Calculate the new oxygen depletion factor, and

(4) Calculate the new rate of heat release.

X2.5.4 *Case 3: O₂, CO₂, and CO are measured:*

- (1) Calculate the mass flow rate of the exhaust gases in X2.5.2,
- (2) Obtain the moisture content of the incoming air as in X2.5.2,
- (3) Calculate the new oxygen depletion factor, and
- (4) Calculate the new rate of heat release.

X2.5.5 Carbon dioxide is eliminated from the gas sample because it may interfere with the oxygen measurement. If a CO₂ analyzer is used, this eliminates the need for removal of CO₂ out of the gas sample. This is mainly of practical importance as the scrubbing agent used to remove CO₂ usually requires careful handling and is rather expensive. If significant amounts of CO are produced (for example at or beyond flashover in ventilation controlled room fires), accuracy of the rate of heat release measurement is greatly improved by measuring CO.

X2.5.6 The presence of a water vapor analyzer simplifies the analysis and improves accuracy even more. Unfortunately, implementation of a water vapor analyzer is not straightforward because heated sampling lines, filters, and so forth, are needed to avoid condensation. Thus, the use of a water vapor analyzer precludes the estimation of the expansion factor. However, for this test method, the use of water analyzers is not recommended.

X2.6 For solid specimens of unknown chemical composition, as used in electrical or optical fiber cables, and other common occupant fuel load, it has been documented that the use of the oxygen consumption standard value of 13.1 MJ/kg oxygen for the net amount of heat released per unit of oxygen consumed for complete consumption results in an expected error band of $\pm 5\%$ compared to the true value. For homogeneous materials with only a single pyrolysis mechanism, this uncertainty is reduced by determining the net heat of combustion from oxygen bomb measurements and the stoichiometric oxygen fuel mass ratio from ultimate elemental analysis. Guide E 603 and Test Method E 1354 contain other details relevant to heat release measurements by oxygen consumption and room fire tests.

X3. METHOD OF DETERMINING SUITABILITY OF OXYGEN ANALYZERS FOR MAKING HEAT RELEASE MEASUREMENTS

X3.1 General

X3.1.1 The type of oxygen analyzer best suited for fire gas analysis is of the paramagnetic type. Electrochemical analyzers or analyzers using zirconia sensors have generally been found not to have adequate sensitivity or suitability for this type of work. The normal range of the instrument to be used is 0 to 25 vol % oxygen. The linearity of paramagnetic analyzers is, normally, better than can be checked by a user laboratory; thus verifying their linearity is not necessary. It is important, however, to confirm the noise and short-term drift of the instrument used.

X3.2 Procedure

X3.2.1 Connect two different gas bottles having approximately two percentage points apart (for example 15 vol % and 17 vol %) to a selector valve at the inlet of the analyzer.

X3.2.2 Connect the electrical power and let the analyzer warm up for 24 h, with one of the test gases from X3.2.1 flowing through it.

X3.2.3 Connect a data acquisition system to the output of the analyzer. Quickly switch from the first gas bottle to the second bottle, and immediately start collecting data, taking one data point per second. Collect data for 20 min.

X3.2.4 Determine the drift by using a least-squares analysis fitting procedure to pass a straight line through the last 19 min of data. Extrapolate the line back through the first min of data. The difference between the readings at 0 min and at 20 min on the fitted straight line represents the short-term drift. Record the drift in units of parts per million of oxygen.

X3.2.5 The noise is represented by the root-mean-square deviation around the fitted straight line. Calculate that root-mean-square value and record it in units of parts per million of oxygen.

X3.2.6 The analyzer is suitable for use in heat release measurements if the sum of the drift plus the noise terms is ≤ 50 ppm oxygen (note that both terms must be expressed as positive numbers).

X3.3 Additional Precautions

X3.3.1 A paramagnetic oxygen analyzer is directly sensitive to barometric pressure changes at its outlet port and to flow rate fluctuations in the sample supply stream. It is essential that the flow rate be regulated. Use either a flow rate regulator of the mechanical diaphragm type, or an electronic mass flow rate controller. In order to protect against errors due to changes in barometric pressure, one of the following procedures should be used: (a) control the back pressure to the analyzer with a back pressure regulator of the absolute-pressure type, or (b) electrically measure the actual pressure at the detector element and provide a signal correction output.

X4. RECOMMENDATIONS ON CABLE CONSTRUCTIONS

X4.1 In terms of the char length, IEEE 1202 has a recommendation for minimizing the number of tests of a cable construction line. Unless otherwise specified, IEEE 1202 recommends testing the minimum size construction and the cable construction with the highest weight ratio of non-metallic material to metallic material in each product line, in product lines employing identical materials.

X4.2 The objective of this recommendation is to find the construction likely to have the greatest difficulty in passing the char length test. There is no information available at present to suggest which construction would result in the severest smoke obscuration test.

X4.3 If a single construction is chosen, to maximize the probability of obtaining the severest test for char length, select the minimum size construction as follows.

X4.3.1 *Multiconductor Cables*—The smallest conductor size in the product line with the fewest conductors.

X4.3.2 *Single Insulated Conductors* —1/0 AWG or such smaller single conductor size authorized for use in cable tray by National Electrical Code ANSI/NFPA 70, latest edition. The testing of a larger size is permitted, provided that it is the smallest size in the product line.

X5. OPTIONAL MEASUREMENTS FOR WHICH THIS STANDARD IS SUITABLE

X5.1 Combustion Gas Analysis Measurements

X5.1.1 If combustion gases are measured, take the gas samples in the exhaust duct at a position where the combustion products are uniformly mixed. Construct the sampling line tubes of a material not influencing the concentration of the gas species to be analyzed. A logical sequence for the gas train is: sampling probe, soot filter, cold trap, plastic drying column and carbon dioxide removal columns (if used), gas path pump, vent valve, flow controller and oxygen analyzer (see Fig. 3-5). The gas train shall also include appropriate spanning and zeroing facilities.

X5.1.2 The concentrations of combustion gases other than carbon oxides are also optional measurements, but their usefulness depends on the chemical composition of the combustible portion of the specimen tested. In some cases it is also advantageous to measure the concentration of gases such as hydrogen cyanide and nitrogen oxides if the combustibles are known to contain nitrogen. In some other cases it is also advantageous to measure the concentration of gases such as hydrogen chloride, hydrogen bromide or hydrogen fluoride if the combustibles are known or suspected to contain the corresponding halogen.

X5.1.3 Measure the concentration of those combustion gas species to be assessed with an instrument having an accuracy of at least ± 0.1 vol % for carbon dioxide and ± 0.02 vol % for carbon monoxide. A suitable output range is 0 to 1 vol % for carbon monoxide and 0 to 10 vol % for carbon dioxide. Take the gas sample from the end of the sampling line. Calculate the time delay, including the time constant of the instrument, from the room of origin. The time delay is a function of the exhaust duct flow rate and shall be a maximum of 30 s.

X5.1.4 Gas concentration measurements require the use of appropriate time shifts in order to account for gas transit time within the sampling system.

X5.1.5 Analyzers found suitable for carbon monoxide or carbon dioxide concentration measurements are nondispersive infrared analyzers. See Guide E 800 for further details.

X5.1.6 Guide E 800 provides details of suitable analyzers to measure, for special purposes, the concentration of other gases, such as water, total hydrocarbon, nitrogen oxide, hydrogen cyanide, hydrogen fluoride, hydrogen chloride or hydrogen bromide.

X5.2 Gas Yield Measurement Calculations

X5.2.1 Calculate the gas yields (f) using the following equation (Eq X5.1):

$$f_x = \frac{\int \text{mass flow rate of gas}_x dt}{\text{mass loss of specimen}} \quad (\text{X5.1})$$

Calculate the numerator in this equation by summing the product of the fraction of combustion gas by the total mass flow rate, measured at each scan, multiplying it by the total time period involved and dividing by the number of scans, as shown in Eq X5.2:

$$f_x = \frac{\left(\sum_i ([x]_i \times \dot{m}_{e(i)} \times \Delta t_i) \right) \times 0.001 \times \frac{M_x}{M_a}}{\text{mass loss of specimen}} \quad (\text{X5.2})$$

In this equation, $[x]$, the concentration of gas x , is expressed in ppm, \dot{m}_e , the mass flow rate, calculated by Eq A34.2 or Eq A34.3, is expressed in kg s^{-1} , M_x is the molecular weight of gas species x , Δt is the scan period, and mass loss of specimen is the mass

lost over the period over which the gas yield is calculated, and is expressed in g, with 0.001 a conversion factor, to account for the unit changes.

X5.2.2 Report gas concentrations on a dry gas basis, unless water concentrations are being measured.

X5.3 Calibration

X5.3.1 The calibrations described in Section 9 do not address measurements of combustion gas concentrations. The appropriate instruments also need to be carefully calibrated with standard sources.

X5.3.2 Calibrate all instruments carefully with standard sources after initial installation. Perform recalibration tests routinely on the entire system, for example using standard output burners.

X5.3.3 Calibrate gas analyzers daily, prior to testing (see Guide E 800 for further details).

X5.4 Report of Optional Test Measurements

X5.4.1 *Table of Optional Numerical Results:*

X5.4.1.1 Average yield of carbon monoxide (g CO/g fuel),

X5.4.1.2 Average yield of carbon dioxide (g CO₂/g fuel),

X5.4.1.3 Carbon monoxide/carbon dioxide molar yield ratio, and

X5.4.1.4 Average yield of any other measured gas (g gas/g fuel).

X5.4.2 *Optional Graphical Results :*

X5.4.2.1 Plot of concentration of carbon monoxide versus time,

X5.4.2.2 Plot of concentration of carbon dioxide versus time, and

X5.4.2.3 Plots of concentration of any other measured gas versus time.

REFERENCES

- (1) ASME, "Fluid Meters—Their Theory and Applications," Report of the ASME Committee on Fluid Meters, H. Bean, Ed., Sixth Edition, 1971.
- (2) Ower, E., Coaker, A. W., Hirschler, M. M., and Pankhurst, R., "The Measurement of Air Flow," Pergamon Press, 5th Edition, 1977, pp. 112–147.
- (3) Hirschler, M. M., "Survey of Fire Testing of Electrical Cables," M. M. Hirschler, Ed., *Fire and Materials*, Vol 16, 1992, pp. 107–118.
- (4) Ostman, B., "Comparison of Smoke Release from Building Products," "Int. Conf: Fire, Control the Heat ... Reduce the Hazard," London, UK, Fire Research Station, UK, Paper 8, October 24–25, 1988.
- (5) Mikkola, E., (VTT, Finland), First International Cone Calorimeter Users' Seminar and Workshop, London, UK, Jan. 19, 1990.
- (6) ASME, "Fluid Meters—Their Theory and Applications," Report of the ASME Committee on Fluid Meters, H. Bean, Ed., Sixth Edition, 1971.
- (7) Ower, E., and Pankhurst, R., "The Measurement of Air Flow," Pergamon Press, 5th Edition, 1977, pp. 112–147.
- (8) McCaffrey, B., and Heskestad, G., *Combustion and Flame*, Vol. 26, 1976, pp. 125–127.
- (9) Janssens, M. L., "Measuring Rate of Heat Release by Oxygen Consumption," *Fire Technology*, Vol 27, 1991, pp. 234–249.
- (10) Babrauskas, V., Lawson, J., Walton, W., and Twilley, W., "Upholstered Furniture Heat Release Rates Measured with the Furniture Calorimeter," *NBSIR 82-2604*, National Bureau of Standards, Gaithersburg, MD, 1983.
- (11) Thomas, P. H., in "Int. Conf. Fire: Control the Heat ... Reduce the Hazard," London, UK, QMC Fire and Materials Centre, Paper 1, October 24–25, 1988.
- (12) Babrauskas, V., in "Int. Conf. Fire: Control the Heat ... Reduce the Hazard," London, UK, QMC Fire and Materials Centre, Paper 4, October 24–25, 1988.
- (13) Babrauskas, V., and Peacock, R. D., "Heat Release Rate. The Single Most Important Variable in Fire Hazard," in Fire Retardant Chemicals Association 1990 Fall Technical Meeting, Pontevedra Beach, FL, October 22–24, 1990, Technomic, Lancaster, PA, pp. 67–79.
- (14) Hirschler, M. M., "How to Measure Smoke Obscuration in a Manner Relevant to Fire Hazard Assessment: Use of Heat Release Calorimetry Test Equipment," *Journal of Fire Sciences*, Vol 9, 1991, pp. 183–222.
- (15) Huggett, C., "Estimation of Rate of Heat Release by Means of Oxygen Consumption Measurements," *Fire and Materials*, Vol 4, 1980, pp. 61–65.
- (16) Parker, W. J., "Calculations of the Heat Release Rate by Oxygen Consumption for Various Applications," *NBSIR 82-2427-1*, National Bureau of Standards, Gaithersburg, MD, 1982.
- (17) Parker, W. J., "Calculations of the Heat Release Rate by Oxygen Consumption for Various Applications," *Journal of Fire Sciences*, Vol 2, September/October, 1984, pp. 380–395.
- (18) Hirschler, M. M., in "Fire and Polymers: Hazards Identification and Prevention," G. L. Nelson, Ed., American Chemical Society, Washington, DC, 1990, p. 462.
- (19) Debanne, S. M., Hirschler, M. M., and Nelson, G. L., "The Importance of Carbon Monoxide in the Toxicity of Fire Atmospheres," *Fire Hazard and Fire Risk Assessment, ASTM STP 1150*, M. M. Hirschler, Ed., ASTM, Philadelphia, PA, 1992, pp. 9–23.
- (20) Gandhi, P. D., Przybyla, L. J., and Grayson, S. J., "Electric Cables Applications," *Heat Release in Fires*, V. Babrauskas and S. J. Grayson, Eds., Elsevier, London, UK, 1992, Chapter 16, pp. 545–563.
- (21) Coaker, A. W., Hirschler, M., Parker, W. J., Tu, K. M., Shakir, Nurbakhsh, S., and Shoemaker, C. L., "Flammability Testing Damant, G. H., "Furniture Flammability: an Investigation of New Vinyl Compounds with Low Flammability and Low Smoke Release in Cables," *Proc. 39th Int.*

Wire and Cable Symposium, US Army CECOM, Fort Monmouth, NJ, 1990, pp. 643–654. the California Technical Bulletin 133 Test. Part III: Full Scale Chair Burns, NISTIR 90-4375, 1990.

- (1722) Coaker, A. W., Hirschler, M. M., and Shoemaker, C. L., “Rate of Heat Release Testing for Vinyl Wire and Cable Materials with Reduced Flammability and Smoke. Full Scale Cable Tray Tests and Small Scale Tests,” *Fire Safety Journal*, Vol 19, 1992, pp. 19–53.
- (18) Hirschler, M. M., “Survey of Fire Testing of Electrical Cables,” M. M. Hirschler, Ed., *Fire and Materials*, Vol 16, 1992, pp. 107–118.
- (19) Hirschler, Hirschler, M. M., and Shakir, S., “Measurements of Cable Fire Properties by Using Heat Release Equipment,” *Flame Retardants’ 92*, Elsevier, London, UK, pp. 77–99.
- (2023) Thornton, W., “The Relation of Oxygen to the Heat of Combustion of Organic Compounds,” *Philosophical Magazine and Journal of Science*, Vol 33, No. 196, 1917.
- (2124) Huggett, C., “Estimation of Rate of Heat Release by Means of Oxygen Consumption Measurements,” *Fire and Materials*, Vol 4, 1980, pp. 61–65.
- (2225) Parker, W., “An Investigation of the Fire Environment in the ASTM E-84 Tunnel Test,” *NBS Technical Note 945*, National Bureau of Standards, Gaithersburg, MD, 1977.
- (2326) Sensenig, D., “An Oxygen Consumption Technique for Determining the Contribution of Interior Wall Finishes to Room Fires,” *NBS Technical Note 1182*, National Bureau of Standards, Gaithersburg, MD, 1980.
- (2427) Parker, W., “Calculations of the Heat Release Rate by Oxygen Consumption for Various Applications,” *NBSIR 812-2427-1*, National Bureau of Standards, Gaithersburg, MD, 1982.
- (2528) Babrauskas, V., “Development of the Cone Calorimeter—A Bench-Scale Rate of Heat Release Apparatus Based on Oxygen Consumption,” *NBSIR 82-2611*, National Bureau of Standards, Gaithersburg, MD, 1982.
- (2629) ASTM, “Proposed Method for Room Fire Test of Wall and Ceiling Materials and Assemblies,” *Annual Book of ASTM Standards*, Volume 04.07, 1983, p. 958.

ASTM International takes no position respecting the validity of any patent rights asserted in connection with any item mentioned in this standard. Users of this standard are expressly advised that determination of the validity of any such patent rights, and the risk of infringement of such rights, are entirely their own responsibility.

This standard is subject to revision at any time by the responsible technical committee and must be reviewed every five years and if not revised, either reapproved or withdrawn. Your comments are invited either for revision of this standard or for additional standards and should be addressed to ASTM International Headquarters. Your comments will receive careful consideration at a meeting of the responsible technical committee, which you may attend. If you feel that your comments have not received a fair hearing you should make your views known to the ASTM Committee on Standards, at the address shown below.

This standard is copyrighted by ASTM International, 100 Barr Harbor Drive, PO Box C700, West Conshohocken, PA 19428-2959, United States. Individual reprints (single or multiple copies) of this standard may be obtained by contacting ASTM at the above address or at 610-832-9585 (phone), 610-832-9555 (fax), or service@astm.org (e-mail); or through the ASTM website (www.astm.org).