



Designation: D 6113 – 02

Standard Test Method for Using a Cone Calorimeter to Determine Fire-Test-Response Characteristics of Insulating Materials Contained in Electrical or Optical Fiber Cables¹

This standard is issued under the fixed designation D 6113; the number immediately following the designation indicates the year of original adoption or, in the case of revision, the year of last revision. A number in parentheses indicates the year of last reapproval. A superscript epsilon (ϵ) indicates an editorial change since the last revision or reapproval.

1. Scope

1.1 This is a fire-test-response standard.

1.2 Several fire-test-response characteristics, including the time to sustained flaming, heat release rate, total heat released, effective heat of combustion, and specific extinction area; are measured or calculated by this test method at a constant radiant heating flux. For specific limitations see also 5.7 and Section 6.

1.3 The tests are conducted by burning the electrical insulating materials contained in electrical or optical fiber cables when the cable test specimens, excluding accessories, are subjected to radiant heat.

1.4 *This standard measures and describes the response of materials, products, or assemblies to heat and flame under controlled conditions, but does not by itself incorporate all factors required for fire hazard or fire risk assessment of the materials, products or assemblies under actual fire conditions.*

1.5 The values stated in SI units are to be regarded as the standard. The values given in parentheses are for information only.

1.6 *This standard does not purport to address all of the safety concerns, if any, associated with its use. It is the responsibility of the user of this standard to establish appropriate safety and health practices and determine the applicability or regulatory limitations prior to use.* For specific precautionary statements, see Section 7.

2. Referenced Documents

2.1 ASTM Standards:

- D 618 Practice for Conditioning Plastics for Testing²
- D 1711 Terminology Relating to Electrical Insulation³
- D 5424 Test Method for Smoke Obscuration of Insulating Materials Contained in Electrical or Optical Fiber Cables When Burning in a Vertical Cable Tray Configuration⁴
- D 5485 Test Method for Determining the Corrosive Effect

- of Combustion Products Using the Cone Calorimeter⁴
- D 5537 Test Method for Heat Release, Flame Spread and Mass Loss Testing of Insulating Materials Contained in Electrical or Optical Fiber Cables When Burning in a Vertical Cable Tray Configuration⁴
- E 176 Terminology of Fire Standards⁵
- E 691 Practice for Conducting an Interlaboratory Study to Determine the Precision of a Test Method⁶
- E 906 Test Method for Heat and Visible Smoke Release Rates for Materials and Products⁵
- E 1354 Test Method for Heat and Visible Smoke Release Rates for Material and Products Using an Oxygen Consumption Calorimeter⁵
- E 1474 Test Method for Determining the Heat Release Rate of Upholstered Furniture and Mattress Components or Composites Using a Bench Scale Oxygen Consumption Calorimeter⁵

2.2 CSA Standard:

- CSA C22.2 No. 0.3, FT4, Vertical Flame Tests: Cables in Cable Trays, Section 4.11.4 in C22.2 No. 0.3, Test Methods for Electrical Wires and Cables⁷

2.3 IEC Standards:

- IEC 695-4 Fire Hazard Testing. Part 4: Terminology Concerning Fire Tests⁸
- IEC 695-5-2 Fire Hazard Testing. Part 5: Guidance for Assessing Smoke Corrosivity from Burning of Electrotechnical Products, Section 2: Test Methods⁸

2.4 IEEE Standard:

- IEEE 1202: Standard for Flame Testing of Cables for Use in Cable Tray in Industrial and Commercial Occupancies, IEEE Standard 1202⁹

2.5 ISO Standards:

⁵ Annual Book of Standards, Vol 04.07.

⁶ Annual Book of Standards, Vol 14.02.

⁷ Available from Canadian Standards Association, 178 Rexdale Blvd., Rexdale, Ontario, Canada, M9W 1R3.

⁸ Available from International Electrotechnical Commission (IEC), 3 Rue de Varembe, Geneva, Switzerland.

⁹ Available from Institute of Electrical and Electronic Engineers, 345 East 47th Street, New York, NY 10017.

¹ This test method is under the jurisdiction of ASTM Committee D09 on Electrical and Electronic Insulating Materials and is the direct responsibility of Subcommittee D09.21 on Fire Performance Standards.

Current edition approved Sept. 10, 2002. Published October 2002. Originally published as D 6113 – 97. Last previous edition D 6113 – 99.

² Annual Book of Standards, Vol 08.01.

³ Annual Book of Standards, Vol 10.01.

⁴ Annual Book of Standards, Vol 10.02.

ISO 13943 Fire Safety: Vocabulary¹⁰
ISO CD 11907-4 Dynamic Method for Measuring Smoke
Corrosivity Using a Radiant Conical Heater¹⁰

2.6 *NFPA Standard:*

NFPA 262 Standard Method of Test for Flame Travel and
Smoke of Wires and Cables for Use in Air-Handling
Spaces¹¹

2.7 *OSHA Standard:*

OSHA 191.1450 Occupational Exposure to Hazardous
Chemicals in Laboratories¹²

2.8 *UL Standards:*

ANSI/UL 910 Standard Test Method for Fire and Smoke
Characteristics of Electrical and Optical Fiber Cables
Used in Air Handling Spaces¹³

ANSI/UL 1581 Reference Standard for Electrical Wires,
Cables, and Flexible Cords¹³

UL 1666 Standard Test for Flame Propagation Height of
Electrical and Optical-Fiber Cables Installed Vertically in
Shafts¹³

UL 1685 Standard Vertical Tray Fire Propagation and
Smoke Release Test for Electrical and Optical Fiber
Cables¹³

3. Terminology

3.1 *Definitions:*

3.1.1 For definitions of terms used in this test method and associated with fire issues use Terminology E 176, ISO 13943 and IEC 695-4. Where differences exist in definitions, those contained in Terminology E 176 shall be used. Use Terminology D 1711 for definitions of terms used in this test method and associated with electrical insulation materials.

3.2 *Definitions of Terms Specific to This Standard:*

3.2.1 *cone calorimeter, n*—the apparatus which is used in Test Method E 1354 to determine heat release rate, by the principle of oxygen consumption calorimetry, and other fire-test-response characteristics.

3.2.2 *effective heat of combustion, n*—the ratio of the measured heat release to the mass loss, under specified test conditions.

3.2.2.1 *Discussion*—The effective heat of combustion is a function of the test conditions, including heating flux, exposure time and test specimen geometry.

3.2.3 *heat release rate, n*—the calorific energy released per unit time by the combustion of a material under specified test conditions.

3.2.4 *heating flux, n*—the prescribed incident power per unit area of test specimen, the power being imposed externally from the heater onto the test specimen at the initiation of the test.

3.2.4.1 *Discussion*—The test specimen, once ignited, is also heated by its own flame.

3.2.5 *ignitability, n*—the measure of the ease with which a specimen can be ignited due to the influence of an external energy source, under specified test conditions.

3.2.6 *net heat of combustion, n*—the quantity of heat released by the complete combustion of a unit mass of the material, the water produced being in the vapor state.

3.2.7 *orientation, n*—the plane in which the exposed face of the test specimen is located during testing, which is horizontal facing up for this test.

3.2.8 *oxygen consumption principle, n*—the expression of the relationship between the mass of oxygen consumed during combustion and the heat released.

3.2.9 *smoke obscuration, n*—the reduction in visibility due to the smoke.

3.2.10 *specific extinction area, n*—a measure of smoke obscuration potential per unit mass lost, determined as the product of the extinction coefficient and the volumetric mass flow rate, divided by the mass loss rate.

3.2.11 *sustained flaming, n*—existence of flame on or over the surface of the test specimen for periods of 4 s or more.

3.2.11.1 *Discussion*—Flaming of less than 4 s duration is identified as flashing or transitory flaming.

3.2.12 *total heat released, n*—integrated value of the rate of heat release, for a specified time period.

4. Summary of Test Method

4.1 All fire-test-response characteristics in this test method are determined using the apparatus and procedures described in Test Method E 1354.

4.2 The oxygen consumption principle, used in this test method, is based on the observation that, generally, the net heat of combustion is directly related to the amount of oxygen required for combustion (1).¹⁴ Approximately 13.1 MJ of heat are released per 1 kg of oxygen consumed. Test specimens in this test method are burned in ambient air conditions, while being subjected to a prescribed external heating flux. (See also X5.1).

4.3 The heat release is determined by the measurement of the oxygen consumption, as determined by the oxygen concentration and the flow rate in the combustion product stream, as described in Test Method E 1354.

4.4 The primary measurements are oxygen concentration and exhaust gas flow rate. Additional measurements include the time to sustained flaming, the smoke obscuration generated, the mass loss rate, and the effective heat of combustion. Ignitability is determined by measuring the time from initial exposure to time of sustained flaming of the test specimen.

4.5 A cone calorimeter is used to measure the consumption of oxygen during this test; heat release is then calculated, based on the oxygen consumption principle. The test specimen is mounted horizontally and a spark ignition source is employed.

5. Significance and Use

5.1 This test method is used to determine the heat release rate and a number of other fire-test-response characteristics as

¹⁰ Available from International Organization for Standardization (ISO), PO Box 56, Geneva 20, CH 1211, Switzerland.

¹¹ Available from National Fire Protection Association (NFPA), 1 Batterymarch Park, Quincy, MA 02269-9101.

¹² Available from Occupational Health and Safety Administration, 200 Constitution Avenue NW, Washington, DC, 20210.

¹³ Available from Underwriters Laboratories, Inc., 333 Pfingsten Rd, Northbrook, IL, 60062.

¹⁴ The boldface numbers given in parentheses refer to a list of references at the end of this test method.

a result of exposing insulating materials contained in electrical or optical cables to a prescribed heating flux in the cone calorimeter apparatus.

5.2 Quantitative heat release measurements provide information that is potentially useful for design of electrical or optical cables, and product development.

5.3 Heat release measurements provide useful information for product development by giving a quantitative measure of specific changes in fire performance caused by component and composite modifications. Heat release data from this test method will not be predictive of product behavior if the product will not spread flame over its surface under the fire exposure conditions of interest.

5.4 The fire-test-response characteristics determined by this test method are affected by the thickness of the material used as test specimen, whether as a plaque or as coating on a wire or cable. The diameter of the wire or cable used will also affect the test results.

5.5 A radiant exposure is used as an energy source for this test method. This type of source has been used for comparison with heat release rate and flame spread studies of insulating materials constructed into cables when burning in a vertical cable tray configuration (Test Methods D 5424 and D 5537) (2-9). No definitive relationships have been established.

5.6 The value of heat release rate corresponding to the critical limit between propagating cable fires and non-propagating fires is not known.

5.7 This test method does not determine the net heat of combustion.

5.8 It has not been demonstrated that this test method is capable of predicting the response of electrical or optical fiber cables in a full scale fire. In particular, this test method does not address the self-extinguishing characteristics of the cables in a full scale fire.

6. Test Limitations

6.1 If during the test of one or more of the three replicate test specimens, any of the following unusual behavior occurs: molten material overflows the specimen holder trough; a test specimen is displaced from the zone of controlled irradiance (explosive spalling); or the test specimen swells sufficiently prior to ignition to touch the spark plug or swells up to the plane of the heater base during combustion; then test an additional specimen of the identical preconditioned test specimens in the test mode in which the unusual behavior occurred. Do not incorporate data obtained from the tests noted above, yielding inadequate results, in the averaged data but report the occurrence. This test method is not suitable if more than three out of six test specimens tested show any of the above characteristics.

6.2 The applicability of this test method to smoldering ignition of cables has not been demonstrated. This test method is not suitable for incident heat fluxes below 10 kW/m^2 .

6.3 The validity of the results of this test method for a particular scenario depends on the conditions under which the tests are conducted. In particular, it has been established that the use of a different heating flux will change relative results.

7. Safety Precautions

7.1 The test procedures involve high temperatures and combustion processes. Hazards therefore exist for burns, ignition of extraneous objects or clothing, and inhalation of combustion products. The operator must take appropriate precautions during the insertion and removal of the test specimens, for example, by using protective gloves. Do not touch either the cone heater or the associated fixtures while hot, except with the use of appropriate protective gear.

7.2 Vent the combustion products flowing through the exposure chamber through a properly designed exhaust system. An adequate method of venting the combustion products captured in the exposure chamber during the test is through an OSHA approved smoke hood¹⁵ at the end of a test.

7.3 Check the exhaust system for proper operation before testing and discharge into a building exhaust system with adequate capacity. Make provisions for collecting and venting any combustion products that for whatever reason are not collected by the exhaust system of the apparatus.

8. Test Specimen

8.1 Size and Preparation:

8.1.1 The types of test specimens permitted are (a) materials in the form of a flat plaque, or (b) electrical insulating materials contained in electrical or optical cables. The test specimen shall be 100 ± 2 by 100 ± 2 mm (approximately 4 ± 0.08 by 4 ± 0.08 in.) in size, or as close to that as possible. Fill the specimen holder as completely as possible with the cable pieces. Make the thickness of a material test specimen in a flat plaque the same as that of the end use of the material in cable construction. If the end use thickness is not known, or if the test is conducted for other purposes, use a thickness of 6.3 ± 0.5 mm (approximately 0.25 ± 0.02 in.). Ensure that the overall characteristics of the test specimens are those of the wire or cable in its end use (wall thickness and overall diameter).

NOTE 1—Overall test specimen thicknesses of less than 2 mm (approximately 0.08 in.) are not recommended, because potential testing errors become larger.

8.1.2 For test specimens of materials in flat plaques, cut the test specimen to a size of 100 ± 2 by 100 ± 2 mm (approximately 4 ± 0.08 by 4 ± 0.08 in.). Wrap the test specimen in a single layer of aluminum foil (0.03 to 0.04 mm (1.2 to 1.6×10^{-3} in.) thick), shiny side towards the test specimen. Place the edge frame over the test specimen and cut the aluminum foil along the open edges at the top of the edge frame to expose the test specimen. Remove the test specimen from the edge frame, place a grid on the exposed face of the test specimen and insert both the test specimen and the grid into the edge frame.

8.1.3 For test specimens of electrical insulating materials contained in electrical or optical fiber cables, cut the cables to 100 ± 2 mm (approximately 4 ± 0.08 in.) lengths to fill the

¹⁵ Use a smoke hood in compliance with OSHA regulations for Occupational Exposure to Hazardous Chemicals in Laboratories - 191.1450.

specimen holder. Seal the ends using an adhesive cement.¹⁶ Apply the adhesive cement to the cable ends such that there are no visible air holes in the coating and that the cement does not overlap the cable ends. Wrap the cable lengths in a single layer of aluminum foil. Place the edge frame over the cable test specimens and cut the aluminum foil along the open edges at the tip of the edge frame and expose the test specimens. Remove the test specimens from the edge frame, place a grid on the exposed face of the test specimens and insert both the test specimen and the grid into the edge frame.

8.1.4 Optionally, for test specimens of electrical insulating materials contained in electrical or optical fiber cables, cut the cables to 100 ± 2 mm (approximately 4 ± 0.08 in.) lengths to fill the specimen holder, without sealing the ends. Wrap the cable lengths in a single layer of aluminum foil. Place the edge frame over the cable test specimens and cut the aluminum foil along the open edges at the tip of the edge frame and expose the test specimens. Remove the test specimens from the edge frame, place a grid on the exposed face of the test specimens and insert both the test specimen and the grid into the edge frame.

NOTE 2—The objective of sealing the cable ends is to prevent gas evolution through such ends, that is not to be expected when a full length of cable is exposed to a fire in actual use. Moreover, the same method of test specimen preparation is used in Test Method D 5485, and the draft international test method ISO CD 11907-4, mentioned in IEC 695-5-2. However, it is unclear whether the results of the cone calorimeter testing are more meaningful with the cable ends sealed or unsealed.

8.2 Condition the test specimens in accordance with Practice D 618 to moisture equilibrium (constant weight) at an ambient temperature of $23 \pm 3^\circ\text{C}$ and a relative humidity of $50 \pm 5\%$.

8.3 Specimen Holder and Mounting:

8.3.1 A specimen holder consists of the bottom, the edge frame, retaining pins and wire grid as shown in Fig. 1. The bottom is constructed from 2 mm nominal stainless steel and has outside dimensions of 111 by 111 ± 2 by 24 ± 2 mm height. The grid is constructed from 1 mm nominal stainless steel and has dimensions of 109 ± 2 by 109 ± 2 mm. The grid has 1 mm ribs and the openings in the center are 19 ± 1 by 19 ± 1 mm. The edge frame is constructed from 2 mm nominal stainless steel with outside dimensions of 116 ± 2 by 116 ± 2 by 56 ± 2 mm height. The frame has an 8 mm lip on the top to provide an opening of 100 by 100 mm on the top. There are two 3 ± 0.5 mm diameter by 130 ± 3 mm long retaining pins to lock the test specimen in the edge frame.

8.3.2 The bottom is lined with a layer of a low density (nominal density 65 kg m⁻³) ceramic fiber refractory blanket with thickness of at least 13 mm. If necessary, fill the edge frame below the test specimens with refractory blanket to the level of the retaining pins. Lock the assembly with retaining pins and place assembly on the bottom specimen holder. The distance between the bottom of the radiant heater and the top of the edge frame is adjusted to 25 ± 1 mm by using a sliding height adjustment.

9. Procedure

9.1 Preparation:

9.1.1 Calibrate the test apparatus in accordance with Test Method E 1354. Position the cone heater for a horizontal specimen orientation and set the radiant heating flux level to the chosen value, with a tolerance of ± 1 kW/m².

9.1.2 Verify that the distance between the bottom of the cone heater baseplate and the top of the test specimen is 25 mm (approximately 1 in.).

9.1.3 Position the spark igniter at a distance of 13 mm above the test specimen surface.

NOTE 3—As stated in 6.1, if the test specimen comes in contact with the spark igniter or the heater base plate, the test results will not be usable.

9.2 Procedure:

9.2.1 Prepare the data collection system for testing in accordance with the operating procedures for the system in Test Method E 1354. Place the test specimen in the specified holder on the load cell and start data collection. The holder must be at room temperature initially. The data collection intervals shall not exceed 5 s.

9.2.2 Energize the spark igniter and move it into place as rapidly as possible after test specimen insertion.

9.2.3 Start the timer at the beginning of the test. After flaming is first observed, continue the observation for an additional 4 s. At that point record the time and move the spark igniter out of the flame. Determine the time to flaming ignition. Note that the time to ignition is the time for sustained flaming to start; therefore, if the timer is stopped at the end of the 4 s observation period, the time to be reported is that value, minus 4 s.

NOTE 4—If flaming combustion is not observed, report as “No Ignition was Observed” and not as “Time to Ignition Equals Zero”.

9.2.4 Collect data from the start of the test until the first of the following criteria has been reached: average mass loss over a 1-min period has dropped below 1.5 g or 60 min have elapsed. Ensure that the minimum test period is 30 min.

9.2.5 Observe and record physical changes to the test specimen, such as melting, swelling, and cracking.

9.2.6 Remove the specimen holder.

9.2.7 Replace with an empty specimen holder or insulated pad to prevent thermal damage to the load cell.

9.2.8 Test three test specimens under each condition.

10. Calculation

10.1 Use the calculation procedures from Test Method E 1354 for all fire-test-response characteristics.

10.2 Calculate the total heat release per unit area (in kW/m²), average specific extinction area (in m²/kg) and the effective heat of combustion (in MJ/kg) by using data over the entire period indicated in 9.2.4, beginning with the next reading after the last (if any) negative heat release rate reading at the beginning of the test.

NOTE 5—Certain test specimens do not show visible, sustained flaming but do indicate non-zero heat release or smoke obscuration values.

10.3 Calculate the average mass loss rate (in g/s) over the period starting at the time when 10 % of the ultimate test specimen mass loss occurred and ending at the time when 90 %

¹⁶ Adhesive cement, Sauereisen Insa-Lute, available from Sauereisen, 160 Gamma Drive, Pittsburgh, PA 15238, or from Fischer Scientific (Catalog number 04-760-15), is suitable for this application.

ASTM D 6113 – 02

MATERIAL:

STAINLESS 1.84mm THICK

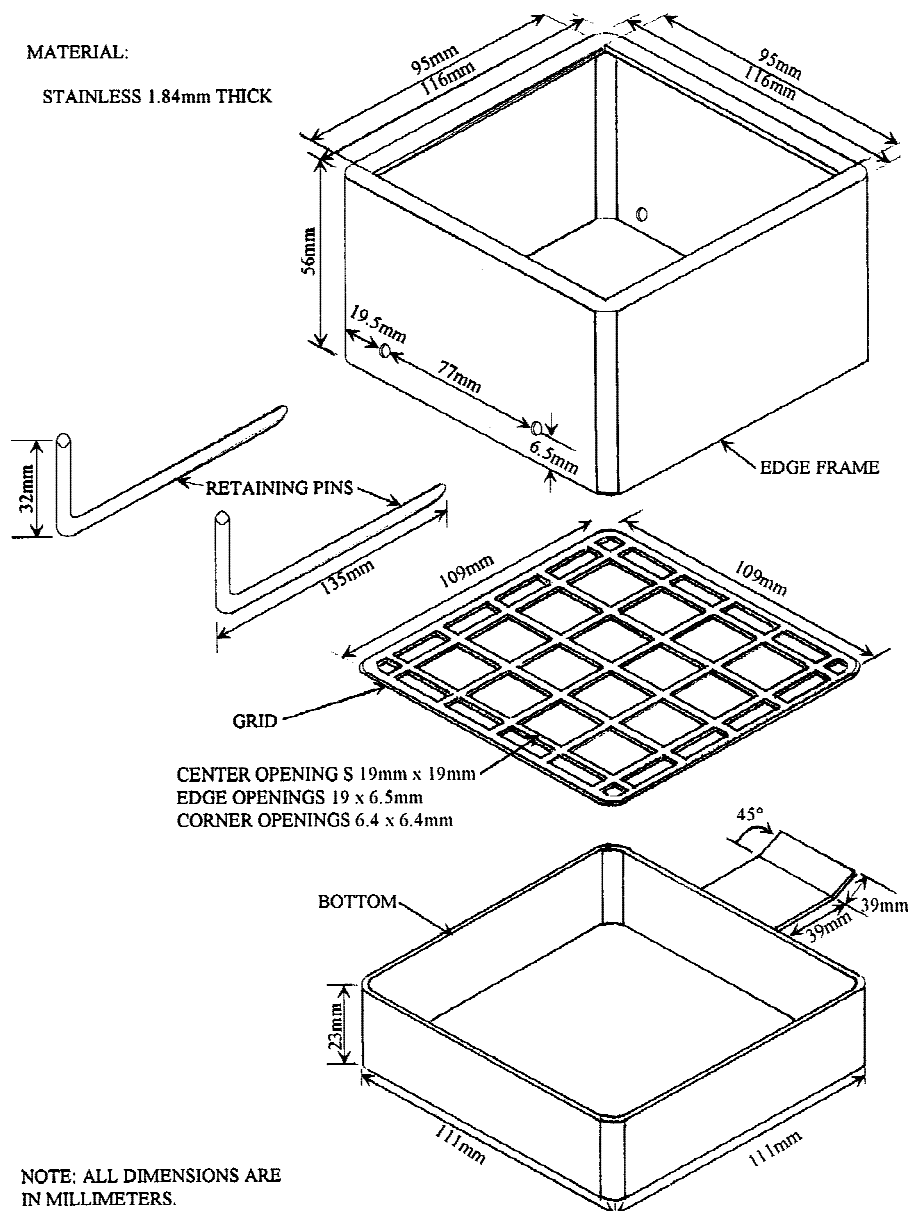

FIG. 1 Specimen Holder

of the ultimate test specimen mass loss occurred.

NOTE 6—This is done in order to get more consistent results.

NOTE 7—For certain materials the mass loss is not representative of the fraction of the test specimen that has burnt. For silicone materials, for example, combustion results in solid residues of products of silicon oxidation, with higher mass than the original test specimen.

11. Report

11.1 Report the following information, as a summary, for all test specimens of a particular material or product:

- 11.1.1 Test specimen identification or number,
- 11.1.2 Manufacturer or submitter,
- 11.1.3 Date of test,
- 11.1.4 Composition or generic identification, and
- 11.1.5 Details of preparation.

11.2 Include the following information for each test specimen:

TABLE 1 Results of Inter-Laboratory Trials for Test Method E 1354^A

Property	TTI	Pk RHR	Avg RHR	THR	EHC	SEA
Units	s	kW/m ²	kW/m ²	MJ/m ²	MJ/kg	m ² /kg
Range	5 to 150	70 to 1120	70 to 870	5 to 720	7 to 40	30 to 2200
<i>r</i>
A	4.1	13.3	23.3	7.4	1.23	59.0
B	0.125	0.131	0.037	0.068	0.050	0.076
<i>R</i>
A	7.4	60.4	25.5	11.8	2.42	63.0
B	0.220	0.141	0.151	0.088	0.055	0.215

^A Abbreviations used: TTI: time to sustained flaming; Pk RHR: maximum heat release rate; Avg RHR: average heat release rate in the 180 s following ignition; THR: total heat released; EHC: effective heat of combustion; range: range of results obtained in the inter-laboratory evaluation; SEA: average specific extinction area.

11.2.1 Test specimen thickness (mm),

- 11.2.2 Test specimen initial mass, measured on the load cell (g),
- 11.2.3 If the test specimen is in the form of electrical insulating materials contained in electrical or optical cables, the number of lengths of cable, and the diameter of the cable,
- 11.2.4 Heating flux and initial exhaust system flow rate,
- 11.2.5 Time to sustained flaming (s),
- 11.2.6 Curve of heat release rate versus time,
- 11.2.7 Average heat release rate for the first 180 s after ignition (kW/m²),
- 11.2.8 Peak heat release rate (kW/m²),
- 11.2.9 Total heat released by the test specimen per unit area for entire test (MJ/m²),
- 11.2.10 Average effective heat of combustion for entire test (MJ/kg),
- 11.2.11 Average specific extinction area for entire test (m²/kg),
- 11.2.12 Mass remaining at test termination (g),
- 11.2.13 Test specimen mass loss (g),
- 11.2.14 Average test specimen mass loss rate for entire test (g/s),
- 11.2.15 Additional observations, if any, and
- 11.2.16 Difficulties encountered in testing, if any.
- 11.3 Average the following final values for all test specimens:
 - 11.3.1 Time to sustained flaming (s),
 - 11.3.2 Average heat release rate value (kW/m²) over the first 180 s after ignition,
 - 11.3.3 Average effective heat of combustion (MJ/kg) for the entire test. This is obtained by dividing the total heat released by the test specimen mass loss,
 - 11.3.4 Peak heat release rate (kW/m²),
 - 11.3.5 Total heat released (MJ/m²),
 - 11.3.6 Average specific extinction area (m²/kg),
 - 11.3.7 Test specimen mass loss (g), and
 - 11.3.8 Average test specimen mass loss rate (g/s).

12. Precision and Bias

12.1 Precision:

12.1.1 The precision of test measurements using the cone calorimeter for materials as flat plaques, in accordance with Test Method E 1354, has been determined by inter-laboratory trials conducted by ASTM Committee E-5 on Fire Standards. The fire-test-response characteristics chosen for determining repeatability and reproducibility were: time to sustained flaming, peak heat release rate, average heat release rate over the

first 180 s after ignition, the total heat released, the effective heat of combustion and the average specific extinction area. The results were expressed in terms of an equation such as:

$$r \text{ (or } R) = A + B * \text{Property} \quad (1)$$

where:

- r = intra-laboratory repeatability;
- R = inter-laboratory reproducibility;
- Property = fire-test-response characteristic considered and A and B are constants.

12.1.2 Results of tests on plaque specimens for the materials test are shown in Table 1.¹⁷

12.1.3 An interlaboratory evaluation, using 4 laboratories, was conducted to assess the precision of the procedure for measuring the heat release rate and other fire-test-response characteristics of electrical insulating materials contained in electrical or optical fiber cables using the cone calorimeter. The specimens used were: a flat plaque of an electrical insulating material and four cables, and were described as follows.

12.1.3.1 Plaque P1: a non commercial poly(vinyl chloride) wire and cable type compound, at a thickness of 6 mm.

12.1.3.2 Cable C1: a cable with a white jacket and an outer diameter of 5 mm, with 4 pairs of 24AWG insulated copper conductors. The wire insulation and outer jacket are polyolefin compounds containing no halogens.

12.1.3.3 Cable C2: a plenum rated (CMP) telephone cable with a blue jacket and an outer diameter of 4 mm, with 4 pairs of 24 AWG solid insulated copper conductors. The wire insulation is fluorinated ethylene propylene and the outer jacket is fire retarded poly(vinyl chloride).

12.1.3.4 Cable C3: a riser rated (CMR) inside telephone switchboard cable with a grey jacket and an outer diameter of 9 mm, with 25 pairs of 24 AWG solid bare copper conductors. The wire insulation and outer jacket are fire retarded poly(vinyl chloride).

12.1.3.5 Cable C4: a vertical tray rated (CM) Type TC control with a black jacket and an outer diameter of 15 mm, with 9 solid insulated 12 AWG copper conductors. The wire insulation is poly(vinyl chloride)/nylon insulation and the outer jacket is poly(vinyl chloride).

12.1.4 Tables 2-7 contain the statistical information on precision for repeatability and reproducibility for the following properties: time to sustained flaming, peak heat release rate,

¹⁷ Supporting data are available from ASTM Headquarters. Request RR: E05-1008.

TABLE 2 Intralaboratory and Interlaboratory Precision Results of Round Robin Evaluation: Time to Sustained Flaming (s)

Material	Heat Flux (kW/m ²)	Average	STD repeat	STD Repro	r	R	RSD repeat	RSD Repro
Plaque P1	50	22.4	3.7	3.7	10	10	16.4	16.4
Plaque P1	25	105.0	1.0		3		1.0	
Cable C1	50	37.2	6.2	6.2	17	17	16.7	16.7
Cable C1	25	236.3	17.2		48		7.3	
Cable C2	50	106.5	65.4	65.4	183	183	61.4	61.4
Cable C2	25	10000.0	0.0		0		0.0	
Cable C3	50	39.8	12.5	12.5	35	35	31.3	31.3
Cable C3	25	251.0	9.8		28		3.9	
Cable C4	50	47.6	6.4	23.9	18	67	13.4	50.3
Cable C4	25	232.1	120.3	120.3	337	337	51.8	51.8
Average Values			24	39			20	38



**TABLE 3 Intralaboratory and Interlaboratory Precision Results of Round Robin Evaluation:
Peak Rate of Heat Release (kW/m²)**

Material	Heat Flux (kW/m ²)	Average	STD repeat	STD Repro	r	R	RSD repeat	RSD Repro
Plaque P1	50	210.3	31.2	31.2	87	87	14.8	14.8
Plaque P1	25	165.6	2.2		6		1.3	
Cable C1	50	292.6	29.0	45.2	81	127	9.9	15.4
Cable C1	25	204.6	5.1		14		2.5	
Cable C2	50	54.8	13.0	13.3	37	37	23.8	24.3
Cable C2	25	9.2	6.2		17		67.4	
Cable C3	50	116.1	8.7	9.9	24	28	7.5	8.5
Cable C3	25	109.8	4.3		12		3.9	
Cable C4	50	185.1	28.2	28.2	79	79	15.2	15.2
Cable C4	25	115.2	10.2	12.6	28	35	8.8	10.9
Average Values			14	23			16	15

**TABLE 4 Intralaboratory and Interlaboratory Precision Results of Round Robin Evaluation:
Average (3 min) Rate of Heat Release (kW/m²)**

Material	Heat Flux (kW/m ²)	Average	STD repeat	STD Repro	r	R	RSD repeat	RSD Repro
Plaque P1	50	159.4	21.6	21.6	61	61	13.6	13.6
Plaque P1	25	134.9	4.3		12		1.0	
Cable C1	50	165.7	20.3	24.4	57	68	16.7	16.7
Cable C1	25	85.3	10.4		29		7.3	
Cable C2	50	24.2	6.7	7.2	19	20	27.7	29.7
Cable C2	25	1.7	0.4		1		0.0	
Cable C3	50	100.4	8.1	9.4	23	26	8.1	9.4
Cable C3	25	83.0	1.3		4		1.6	
Cable C4	50	106.9	9.3	10.6	26	30	8.7	9.9
Cable C4	25	42.8	34.0	34.0	95	95	79.4	79.4
Average Values			12	18			16	26

**TABLE 5 Intralaboratory and Interlaboratory Precision Results of Round Robin Evaluation:
Total Heat Released (kJ)**

Material	Heat Flux (kW/m ²)	Average	STD repeat	STD Repro	r	R	RSD repeat	RSD Repro
Plaque P1	50	860.3	50.9	72.3	142	202	5.9	8.4
Plaque P1	25	1011.1	10.8		30		1.1	
Cable C1	50	492.2	33.6	36.0	94	101	6.8	7.3
Cable C1	25	484.0	28.8		81		5.9	
Cable C2	50	88.9	32.3	43.3	90	121	36.4	48.7
Cable C2	25	129.7	19.8		55		15.3	
Cable C3	50	474.2	33.9	46.6	95	131	7.1	9.8
Cable C3	25	475.5	8.7		24		1.8	
Cable C4	50	1202.7	117.8	117.8	330	330	9.8	9.8
Cable C4	25	1181.8	118.5	123.5	332	346	10.0	10.5
Average Values			46	73			10	16

**TABLE 6 Intralaboratory and Interlaboratory Precision Results of Round Robin Evaluation:
Effective Heat of Combustion (MJ/kg)**

Material	Heat Flux (kW/m ²)	Average	STD repeat	STD Repro	r	R	RSD repeat	RSD Repro
P1	50	14.5	0.8	1.0	2	3	5.9	7.1
P1	25	17.2	0.4		1		2.0	
C1	50	27.9	3.4	3.4	9	9	12.1	12.1
C1	25	31.7	1.2		3		3.7	
C2	50	3.5	1.4	1.4	4	4	38.8	38.8
C2	25	1.6	0.2		1		14.7	
C3	50	11.2	1.0	1.2	3	3	9.3	10.9
C3	25	12.2	0.8		2		6.2	
C4	50	15.0	1.7	1.7	5	5	11.2	11.2
C4	25	14.8	2.2	2.2	6	6	14.8	14.8
Average Values			1	2			12	16

average heat release rate over the first 180 s after ignition, the total heat released, the effective heat of combustion and the average specific extinction area.

NOTE 8—Two laboratories did not report specific extinction area data.

12.1.4.1 The abbreviations used in the tables are as follows:

Average is the overall average of the individual lab averages; STD repeat is the overall standard deviation for repeatability; STD Repro is the overall standard deviation for reproducibility; r is the intra-laboratory repeatability; R is the inter-laboratory reproducibility; RSD repeat is relative standard

**TABLE 7 Intralaboratory and Interlaboratory Precision Results of Round Robin Evaluation:
Specific Extinction Area (kg/m²)**

Material	Heat Flux (kW/m ²)	Average	STD repeat	STD Repro	r	R	RSD repeat	RSD Repro
P1	50	1312.4	105.8	105.8	296	296	8.1	8.1
P1	25	1035.0	24.3		68		2.4	
C1	50	522.1	137.7	137.7	385	385	26.4	26.4
C1	25	294.3	35.6		100		12.1	
C2	50	221.3	31.3	31.3	88	88	14.2	14.2
C2	25	292.7	42.0		117		14.3	
C3	50	966.4	143.7	143.7	402	402	14.9	14.9
C3	25	451.3	12.5		35		2.8	
C4	50	1100.8	76.0	80.4	213	225	6.9	7.3
C4	25	730.6	62.6	66.0	175	185	8.6	9.0
Average Values			67	94			11	13

deviation for repeatability (namely 100 times the ratio of standard deviation and average) and RSD Repro is relative standard deviation for reproducibility. The formulas used are found in Practice E 691.

12.1.5 Figs. 2-7 contain plots of the standard deviations for repeatability (and reproducibility) versus the corresponding averages.

12.2 *Bias*—For solid test specimens of unknown chemical composition, as used in building materials, furnishings, and common occupant fuel load, documentation exists (1, 10) stating that the use of the relationship that approximately 13.1 MJ of heat are released per 1 kg of oxygen consumed results in an expected error band of ± 5 % compared to true value. For homogeneous materials with only a single pyrolysis mecha-

nism, this uncertainty is reduced by determining the net heat of combustion from oxygen bomb measurements and the oxygen-fuel stoichiometric mass ratio from ultimate elemental analysis. For most testing, this is not practical, since test specimens are composites, and usually non-homogeneous. Therefore, they often exhibit several degradation reactions. Therefore, for unknown samples, a ± 5 % accuracy limit is seen. For reference materials, however, careful determination of the ratio of the net heat of combustion to the oxygen-fuel stoichiometric mass ratio makes this source of uncertainty substantially less.

13. Keywords

13.1 cable; cone calorimeter; electrical cable; electrical insulation; fire; fire-test response; heat release; heat release

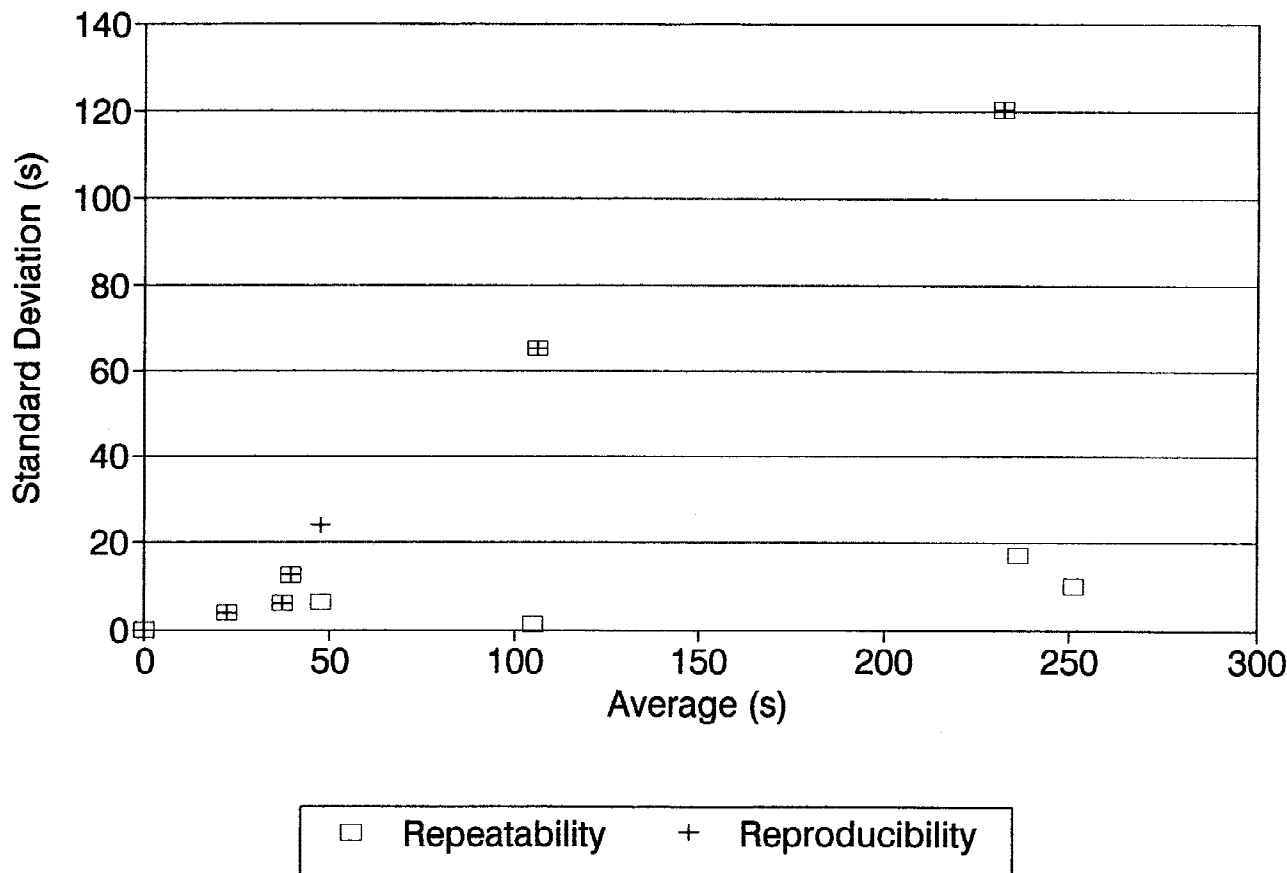

FIG. 2 Time Sustained Flaming Precision

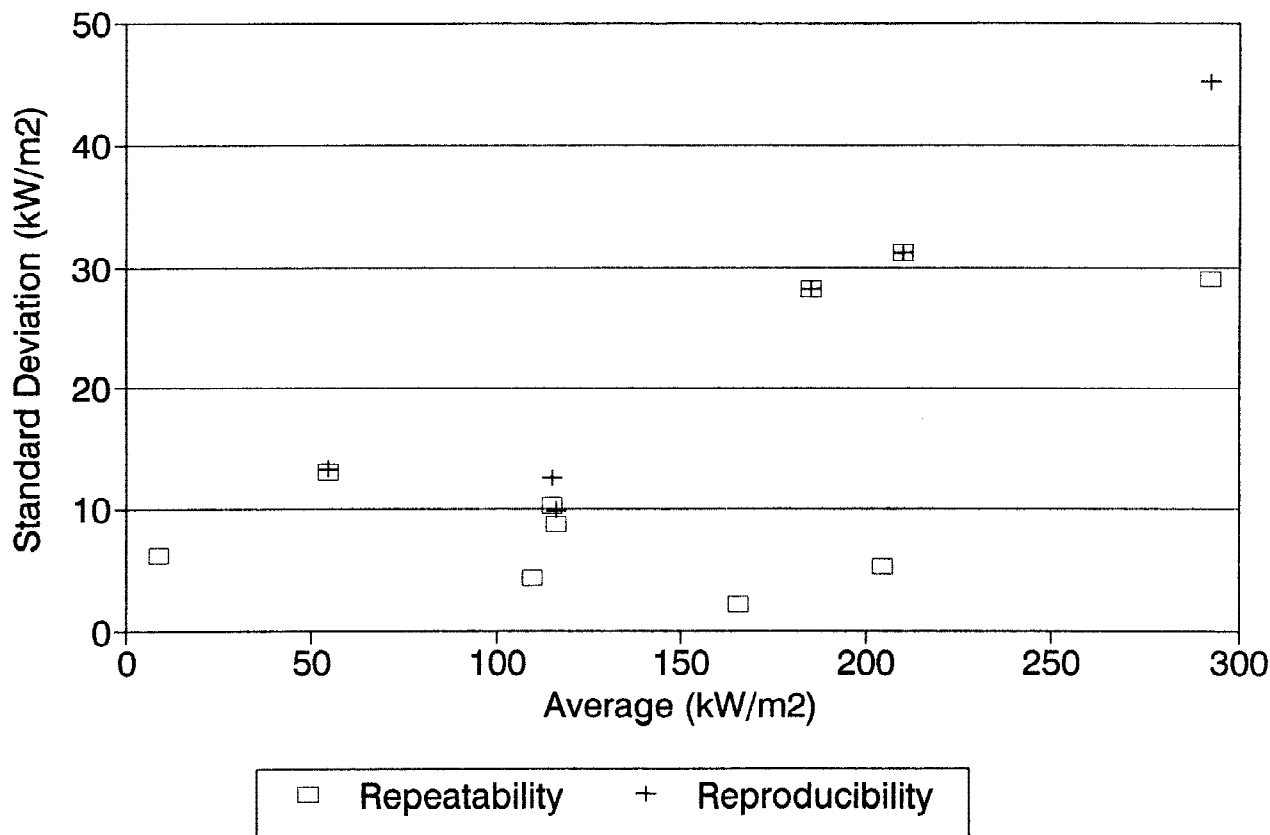

FIG. 3 Peak Heat Release Rate Precision

rate; optical fiber cable; oxygen consumption calorimetry;
smoke obscuration

ANNEX

(Mandatory Information)

A1. CALCULATIONS

A1.1 Traditional practice in cone calorimetry has been the calculation of total heat released per unit area and specific extinction area starting at the time of the first scan after the time to ignition.

A1.2 For the test method described in this standard, the preferred calculation procedure is the one described in Section 10. If calculations are made from time to ignition, this must be explicitly and clearly described in the report.

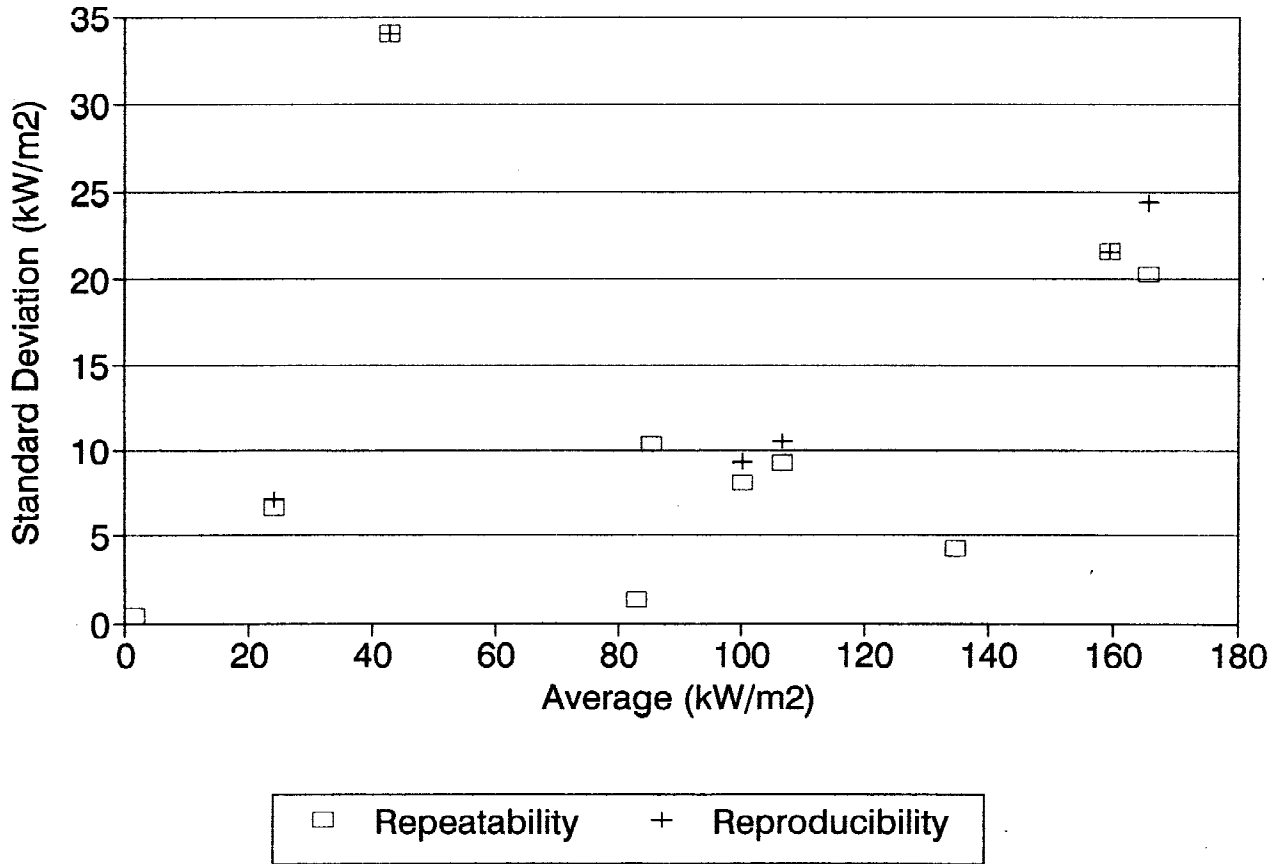

FIG. 4 Average Heat Release Rate Precision

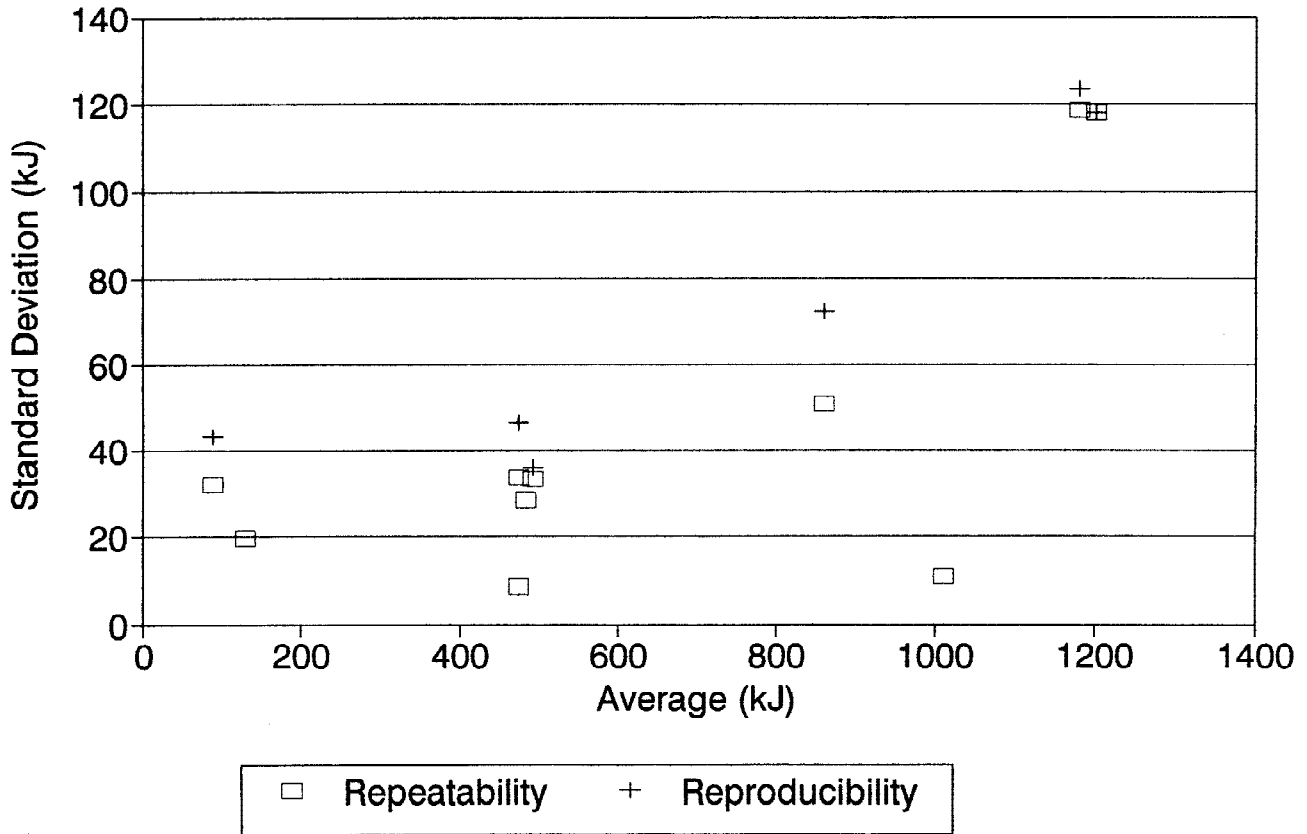

FIG. 5 Total Heat Released Precision

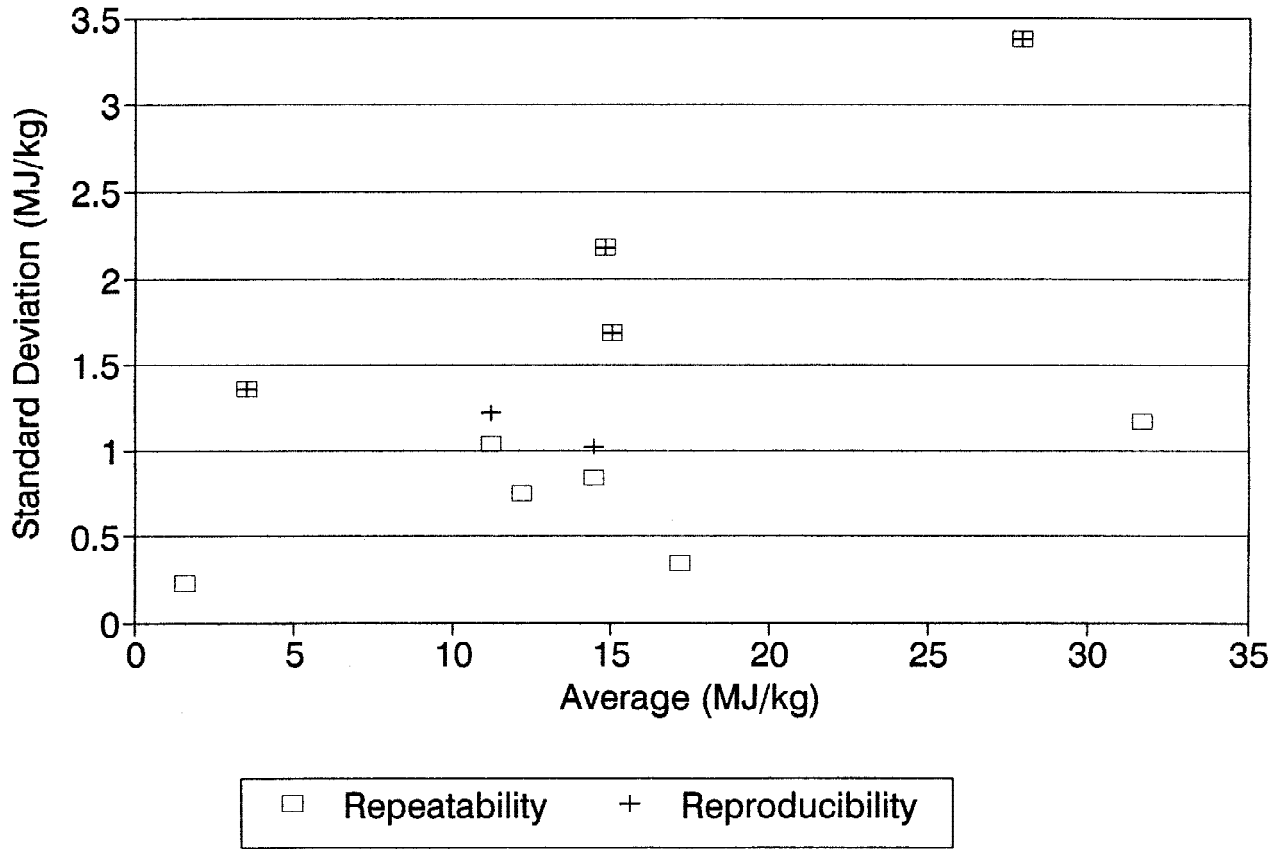

FIG. 6 Eff. Heat Combustion Precision

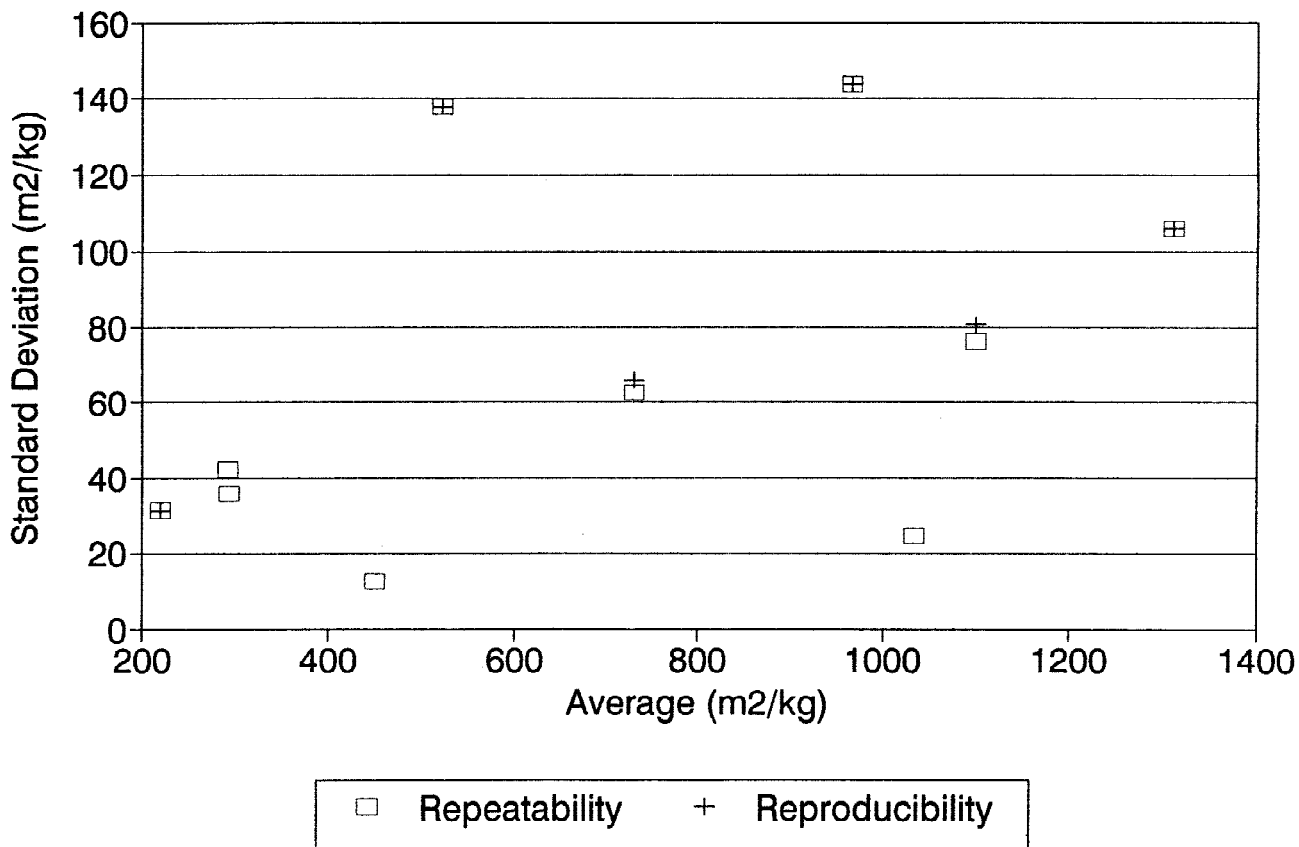

FIG. 7 Spec. Extinction Area Precision

APPENDIXES

(Nonmandatory Information)

X1. COMMENTARY

X1.1 This commentary is provided to give some insight into the development of the test method and to describe a

rationale for various features used, both in the mandatory and the optional sections of this test method.

X2. FIRE PROPERTIES

X2.1 *Smoke Obscuration*—The visibility in a fire atmosphere will adversely affect the ability of occupants of a building, or vehicle, to escape and the ability of fire fighters to control or extinguish the fire.

X2.1.1 The degree of smoke obscuration is a physical observation made during an actual fire. Specific extinction area is a fire-test-response characteristic of a sample, determined in a test apparatus, such as the cone calorimeter, and related to the reduction of light transmitted per unit mass burnt (see 3.2.10).

X2.1.2 There is no simple direct correlation between specific extinction area, as measured in the cone calorimeter, and the degree of smoke obscuration in an actual large scale fire. However, the smoke obscuration in a room of specified size and ventilation has been approximated by using some of the fire-test-response characteristics obtained from this test method, including the specific extinction area, the heat release

rate and the effective heat of combustion (11).

X2.2 *Rate of Heat Release:*

X2.2.1 Rate of heat release is one of the most important variables, possibly even the single most important variable, in determining the hazard from a fire (12-16). In particular, the rate of heat release is a measure of the intensity of the fire (13, 16). The rate of heat release and the amount of heat released in actual fires will determine the extent to which other materials, products or assemblies in the fire compartment may ignite and spread the fire further. The amount of smoke generated is usually a direct function of the heat release rate, particularly in large scale tests (5-9).

X2.2.2 The rate of heat release can be determined by measuring the oxygen depletion in a fire atmosphere (1, 17,

18). Oxygen concentration measurement devices, of the paramagnetic type, are now sufficiently precise to measure the small differences in oxygen concentration needed for determining rate of heat release.

X2.3 Effective Heat of Combustion:

X2.3.1 The effective heat of combustion is determined, in the cone calorimeter, as the summation of the products of the instantaneous heat release rate values at every scan and the scan time, divided by the mass loss, over the entire test length. This is equivalent to the ratio between the total heat released (in MJ) and the total mass lost (in kg).

X2.3.2 The effective heat of combustion is different from the net (or gross) heat of combustion. The latter is the thermodynamic energy generated when the chemical species are completely combusted to their final products, namely when all the carbon, hydrogen and oxygen in the molecules is converted into carbon dioxide and water. This net heat of combustion is usually measured in a bomb calorimeter.

X2.3.3 In actual fires, materials very rarely get totally converted into carbon dioxide and water. If they were, a fire atmosphere would be virtually nontoxic. In fact, carbon monoxide and organic compounds, such as hydrocarbons, aldehydes, and ketones, are usually found in fires, which is an indication that the combustion has been incomplete.

X2.3.4 Since the effective heat of combustion is obtained as the ratio of the total heat released and the mass loss, it represents, thus, the best estimate of the actual heat that would be released per unit mass of material in a fire, when the heat source has the same intensity as the applied heating flux in the cone calorimeter test method.

X2.3.5 The effective heat of combustion depends on the heating flux applied. Thus, it is particularly important, in order

to determine effective heat of combustion, for the heating flux applied to be sufficient to cause consistent test specimen ignition (sustained flaming), and to represent the scenario of interest.

X2.3.6 Data have been published indicating that the effective heat of combustion does not vary considerably once the heating flux is high enough for consistent specimen ignition (10, 19, 20, 21). In other words, replicate tests should always lead to specimen ignition. This is not the case for all materials or products that can be tested in the cone calorimeter and therefore the conditions of test must be described explicitly (22).

X2.3.7 The effective heat of combustion is a constant during combustion of essentially homogeneous samples having only a single mode of degradation. An example of a material with a single mode of degradation is poly(methyl methacrylate), although it is not used as an electrical insulation material.

X2.4 Critical Flux for Ignition:

X2.4.1 The theoretical critical flux for ignition is the minimum heating flux to cause ignition of the sample. It is normally determined as the intercept of a plot of the square root of the inverse of the time to ignition as a function of heating flux.

X2.4.2 In order to determine the critical flux for ignition with sufficient accuracy it is essential to have fire test data at a minimum of three heating fluxes. The precision of the results is likely to increase if the number of tests increases, particularly if the data has been generated at several different heating fluxes.

X2.4.3 If no ignition is observed at a certain heating flux, the use of a higher heating flux is likely to generate data more appropriate for input into fire hazard assessment calculations.

X3. ELECTRICAL OR OPTICAL FIBER CABLES

X3.1 Traditional fire tests on cables have used cable trays. Test methods, such as those in UL 1581, UL 1685, CSA FT4, or IEEE 1202, have focussed on fire propagation and have been used for classification of cables for use in cable trays. Test Methods D 5424 and D 5537 measure, additionally, release of heat, smoke, and carbon oxides and mass loss. Optional measurements of heat release are also included in UL 1685.

X3.2 Cable damage in vertical cable tray fire tests has traditionally been the criterion for assessing fire propagation, in terms of the maximum char length or flame height. This gives

a simple indication of cable fire propagation.

X3.3 Other, more severe, fire tests have also been designed for cables: UL 1666 and UL 910 (similar to NFPA 262). The flame propagation height of riser cables is assessed with UL 1666, while NFPA 262 or UL 910 is used for cables intended for air handling spaces, such as plenums.

X3.4 A number of references have been published wherein measurements of heat release rate of electrical cables were made using the cone calorimeter (2-9).



X4. CONE CALORIMETER

X4.1 The cone calorimeter, Test Method E 1354, is one of the small-scale test instruments capable of being used to measure heat release rate. The other best known methods are the Ohio State University heat release rate calorimeter (see Test Method E 906 (23, 24) and the Factory Mutual apparatus (25, 26).

X4.2 It has been shown that the cone calorimeter is useful for measuring heat release rates of test specimens representing a variety of materials (10-19) and several products, including

electrical cables (2-9), upholstered furniture and mattress composites (see Test Method E 1474) (27-30) and wall coverings (31).

X4.3 One of the most frequent combinations of heating fluxes used for measurements of heat release of electrical cables in the cone calorimeter has been testing at 20, 40, and 70 kW/m²(2-9). Other heating fluxes have also been used.

X4.4 The heating fluxes to be chosen for this test method should be relevant to the fire scenario being investigated.

X5. APPLICABILITY OF THE OXYGEN CONSUMPTION PRINCIPLE

X5.1 The value of 13.1 MJ of heat release per 1 kg of oxygen consumed is valid for the majority of combustible materials (1, 10), and should be used unless an alternate value

has been determined, and properly documented, for the materials being tested.

X6. ALTERNATIVE MOUNTING METHODS

X6.1 Heat Release of Cable Materials at Equal Length:

X6.1.1 When it is desired to compare cables at equal length, it would be desirable not to fill the specimen holder completely with 100 mm lengths of cable with every test specimen. In such cases, the recommended procedure is as shown in X6.1.1.1-X6.1.1.4.

X6.1.1.1 Choose, from the various cables for which the comparison is to be made, the one with the greatest outside diameter.

X6.1.1.2 Follow the instructions of 8.1 for preparing test specimens of that particular cable.

X6.1.1.3 Measure the total length of the test specimen for that cable.

X6.1.1.4 Use the test specimen length determined in X6.1.1.3 with all other cable test specimens that are to be tested in this comparative analysis.

X6.1.2 Following the calculation of heat release rate per unit area, convert the value obtained into heat release rate per unit length, by multiplying the value by the exposed surface area and dividing it by the exposed length of cable.

X6.1.2.1 Make the same calculation for total heat release.

X6.1.3 This method should not be used for cables with outside diameters exceeding 15 mm.

REFERENCES

- (1) Huggett, C., "Estimation of Rate of Heat Release by Means of Oxygen Consumption Measurements," *Fire and Materials*, 4, 1980, pp. 1061-1065.
- (2) Gandhi, P.D., Przybyla, L.J., and Grayson, S.J., "Electric Cables Applications," Chapter 16, in *Heat Release in Fires*, Elsevier, London, UK, V. Babrauskas and S.J. Grayson, eds. 1992, pp. 545-563.
- (3) Coaker, A.W., Hirschler, M.M., Shakir, S., and Shoemaker, C.L., "Flammability Testing of New Vinyl Compounds with Low Flammability and Low Smoke Release in Cables," *Proceedings 39th. International Wire and Cable Symposium*, Nov. 13-15, Reno, NV, pp. 643-654, US Army CECOM, Fort Monmouth, NJ, 1990.
- (4) Babrauskas, V., Peacock, R.D., Braun, E., Bukowski, R.W., and Jones, W.W., *Fire Performance of Wire and Cable; Reaction-to-Fire Tests - A Critical Review of the Existing Methods and of New Concepts*, NIST Tech. Note 1291, National Institute of Standards and Technology, Gaithersburg, MD 1991.
- (5) Coaker, A.W., Hirschler, M.M., and Shoemaker, C.L., "Rate of Heat Release Testing for Vinyl Wire and Cable Materials with Reduced Flammability and Smoke, Full Scale Cable Tray Tests and Small Scale Tests," *Fire Safety Journal*, 19, 1992, pp. 19-53.
- (6) Hirschler, M.M., "Survey of Fire Testing of Electrical Cables," *Fire and Materials*, 16, 1992, pp. 107-118.
- (7) Hirschler, M.M. and Shakir, S., "Measurements of Cable Fire Properties by Using Heat Release Equipment," *Flame Retardants '92, Plastics and Rubber Institute Fire Retardants Tech. Mtg*, Elsevier, London, UK, Jan. 22-23, 1992, pp. 77-99.
- (8) Hirschler, M.M., "Can Heat Release Really Predict the Flame Spread of Electrical Cables?," *Proceedings 2nd International Conference on Fire and Materials*, Crystal City, VA, Sept. 25-26, 1993, pp. 181-190.
- (9) Hirschler, M.M., "Use of Large Scale Heat Release Testing to Predict Flame Spread of Electrical Cables," *4th. Symposium, International Association Fire Safety Science*, Ottawa, Canada, June 13-17, 1994.
- (10) Babrauskas, V., and Grayson, S.J., eds., "Heat Release in Fires," Elsevier Applied Science Publishers, London, UK, 1992.
- (11) Gandhi, P.D., "Using Calorimeter Data and a Zone Model to Predict Smoke Obscuration in Room Fires - A Parametric Study," *Fire Safety Journal*, 20, 1993, pp. 115-133.

 **D 6113 – 02**

- (12) Babrauskas, V., Lawson, J., Walton, W., and Twilley, W., "Upholstered Furniture Heat Release Rates Measured with the Furniture Calorimeter," *NBSIR 82-2604*, 1083.
- (13) Thomas, P.H., in "International Conference FIRE: Control the Heat...Reduce the Hazard," London, UK, QMC Fire and Materials Centre, Paper 1, Oct. 24–25, 1988.
- (14) Babrauskas, V., in "Int. Conf. FIRE: Control the Heat...Reduce the Hazard," London, UK, QMC Fire and Materials Centre, Paper 4, Oct. 24–25, 1988.
- (15) Hirschler, M.M., "How to Measure Smoke Obscuration in a Manner Relevant to Fire Hazard Assessment: Use of Heat Release Calorimetry Test Equipment," *Journal of Fire Sciences*, 9, 1991, pp. 183–222.
- (16) Babrauskas, V., and Peacock, R.D., "Heat Release Rate, The Single Most Important Variable in Fire Hazard," *Fire Safety Journal*, 18, 1992, pp. 255–272.
- (17) Parker, W.J., "Calculations of the Heat Release Rate by Oxygen Consumption for Various Applications," *NBSIR 82-2427-1*, 1982.
- (18) Parker, W.J., "Calculations of the Heat Release Rate by Oxygen Consumption for Various Applications," *Journal of Fire Sciences*, 2 September/October, 1984, pp. 380–395.
- (19) Tran, H.C., "Experimental Data on Wood Materials," Chapter 11 b, *Heat Release in Fires*, Elsevier, London, UK, V. Babrauskas and S.J. Grayson, eds., 1992, pp. 357–372.
- (20) Hirschler, M.M., "Heat Release From Plastics," Chapter 12 a, *Heat Release in Fires*, Elsevier, London, UK, Eds. V. Babrauskas and S.J. Grayson, 1992, pp. 375–422.
- (21) Gandhi, P.D., "Comparison of Cone Calorimeter Results with UL94 Classification for Some Plastics," *Proceedings Fifth Annual BCC Conference on Flame Retardancy*, Stamford, CT, May 24–26, 1994.
- (22) Hoover, J.R., Caudill, L.M., Chapin, J.T., Walnock, J.T. and Clarke, F.B., "Wire and Cable Combustion Efficiency Determinations Using Cone Calorimetry and the Oxygen Bomb," *National Fire Protection Research Foundation Symposium on Fire Risk and Fire Hazard Assessment*, June 1996, San Francisco, CA, pp. 261–276, National Fire Protection Association, Quincy, MA, 1996.
- (23) Smith, E.E., "Measuring Rate of Heat, Smoke and Toxic Gas Release," *Fire Technology*, 1972, pp. 237–245.
- (24) Smith, E.E., "Heat Release Rate of Building Materials," *Ignition, Heat Release and Non-Combustibility of Materials*, ASTM STP 502, A.F. Robertson, ed., American Society for Testing and Materials, Conshohocken, PA, USA, 1972, pp. 119–134.
- (25) Tewarson, A., "Experimental Evaluation of Flammability Parameters of Polymeric Materials," Chapter 3, *Flame Retardant Polymeric Materials*, Vol 3, M. Lewin, S.M. Atlas and E.M. Pearce, eds., Plenum Press, New York, NY, 1982, pp. 97–153.
- (26) Tewarson, A., "Generation of Heat and Chemical Compounds in Fires," *The SFPE Handbook of Fire Protection Engineering*, Society of Fire Protection Engineers, Boston, MA, 1988, pp. 1–199.
- (27) Parker, W. J., Tu, K.-M., Nurbakhsh, S., and Damant, G. H., "Furniture Flammability: An Investigation of the California Technical Bulletin 133 Test, Part III: Full Scale Chair Burns," *NISTIR 4375*, National Institute of Standards and Technology (NIST), Gaithersburg, MD, 1990.
- (28) Hirschler, M. M., and Smith, G. F., "Flammability of Sets of Fabric/Foam Combinations for Use in Upholstered Furniture," *Fire Safety Journal*, 16, 1990, pp. 13–31.
- (29) Hirschler, M. M., and Shakir, S., "Comparison of the Fire Performance of Various Upholstered Furniture Composite Combinations (Fabric/Foam) in Two Rate of Heat Release Calorimeters: Cone and Ohio State University Instruments," *Journal of Fire Sciences*, 9, 1991, pp. 223–248.
- (30) Babrauskas, V., "Bench-Scale Predictions of Mattress and Upholstered Chair Fires-Similarities and Differences," *NISTIR 5152*, National Institute of Standards and Technology (NIST), Gaithersburg, MD, 1993.
- (31) Fritz, T., and Hunsberger, P., "Cone Calorimeter Tests of Wall Coverings," in *Proceedings 1st. International Conference on Fire and Materials*, Crystal City, VA, Sept. 24–25, 1992, pp. 117–123.

ASTM International takes no position respecting the validity of any patent rights asserted in connection with any item mentioned in this standard. Users of this standard are expressly advised that determination of the validity of any such patent rights, and the risk of infringement of such rights, are entirely their own responsibility.

This standard is subject to revision at any time by the responsible technical committee and must be reviewed every five years and if not revised, either reapproved or withdrawn. Your comments are invited either for revision of this standard or for additional standards and should be addressed to ASTM International Headquarters. Your comments will receive careful consideration at a meeting of the responsible technical committee, which you may attend. If you feel that your comments have not received a fair hearing you should make your views known to the ASTM Committee on Standards, at the address shown below.

This standard is copyrighted by ASTM International, 100 Barr Harbor Drive, PO Box C700, West Conshohocken, PA 19428-2959, United States. Individual reprints (single or multiple copies) of this standard may be obtained by contacting ASTM at the above address or at 610-832-9585 (phone), 610-832-9555 (fax), or service@astm.org (e-mail); or through the ASTM website (www.astm.org).