



Designation: D 669 – 92 (Reapproved 1997)

Standard Test Method for Dissipation Factor and Permittivity Parallel with Laminations of Laminated Sheet and Plate Materials¹

This standard is issued under the fixed designation D 669; the number immediately following the designation indicates the year of original adoption or, in the case of revision, the year of last revision. A number in parentheses indicates the year of last reapproval. A superscript epsilon (ϵ) indicates an editorial change since the last revision or reapproval.

1. Scope

1.1 This test method covers the determination of the dissipation factor and permittivity of stiff laminated sheet and plate insulating materials in a direction parallel with the laminations. This test method primarily includes information covering the preparation of the specimen, and details concerning the procedure required to make measurements parallel with the laminations for this particular type of material. The apparatus and general test procedure shall be in accordance with Test Methods D 150.

1.2 The values stated in inch-pound units are to be regarded as the standard.

1.3 *This standard does not purport to address all of the safety concerns, if any, associated with its use. It is the responsibility of the user of this standard to establish appropriate safety and health practices and determine the applicability of regulatory limitations prior to use.* For a specific warning statement see 9.2.

2. Referenced Documents

2.1 ASTM Standards:

D 150 Test Methods for AC Loss Characteristics and Permittivity (Dielectric Constant) of Solid Electrical Insulating Materials²

3. Significance and Use

3.1 It has long been recognized that dissipation factor and permittivity of laminated insulation as measured in a direction perpendicular to the laminations are not of the same magnitude as those measured parallel to the laminations. This test method provides a means of obtaining data parallel to the laminations where design parameters require this information.

4. Selection of Test Specimens

4.1 Select material for test that will not show obvious defects in the area where the electrodes are to be applied unless it is the purpose of this test to show the effects of such defects on the properties measured.

5. Specimen Holder

5.1 Construct a frame from $\frac{3}{8}$ -in. (9.5-mm) square metal bars as shown in Fig. 1. Mill slots 0.260 in. (6.60 mm) wide and $\frac{1}{16}$ in. (1.6 mm) deep in two inner and opposite parallel sides of the frame to hold the test material in a parallel position. Insert threaded studs, equipped with nuts, in the open ends of the slotted bars to receive the (unmilled) clamping bars that are to be drawn tightly on the specimen pile-up.

6. Electrodes

6.1 Prepare two thin tinfoil or leadfoil electrodes, 2 to 4 in. (50 to 100 mm) in diameter, depending on the frequency and the type of circuit used in the measurement (see the Appendix of Methods D 150). Preferably, use an electrode diameter so that the capacitance measured is greater than 50 pF. Use of smaller diameter electrodes increases the effects of stray capacitances and decreases the precision of the measurements.

7. Preparation of Test Specimens

7.1 Cut strips of material $0.250 + 0.005 - 0.001$ in. ($6.35 + 0.013 - 0.003$ mm) wide by 5.25 ± 0.015 in. (133.35 ± 0.38 mm) long in sufficient quantity to provide a pile-up of about 5.25 in. (134 mm) when stacked with the cut edges exposed.

7.2 Prepare two sets of test specimen pile-ups, one with the long dimension in the machine direction of the material and the other in the cross-machine direction. Where the machine direction of the paper-base or the warp direction of the fabric-base sheets is known, it shall constitute the length-wise direction. Otherwise, consider the longer direction of the sheet material the lengthwise direction. If the material sheet has the same length and width, then arbitrarily designate one dimension as the length.

7.3 Mount the strips in the specimen holder with the uncut surfaces adjacent to each other and the cut edges exposed. When testing thick sheets of material, it is permissible to reduce the width of the two outside strips to allow mounting in the frame. Apply pressure to the strips by tightening the two nuts on the crossbar. This can be facilitated by laying the assembly on a flat surface so that the strips and not the frame are supported. Tightening the nuts in this position will ensure that all cut surfaces are in one plane.

7.4 Examine the mounted strips to determine smoothness and freedom from irregularities. Make certain that all burrs

¹ This test method is under the jurisdiction of ASTM Committee D-9 on Electrical and Electronic Insulating Materials and is the direct responsibility of Subcommittee D09.07 on Flexible and Rigid Insulating Materials.

Current edition approved Jan. 15, 1992. Published March 1992. Originally issued as D 669 – 42 T. Last previous edition D 669 – 87.

² *Annual Book of ASTM Standards*, Vol 10.01.

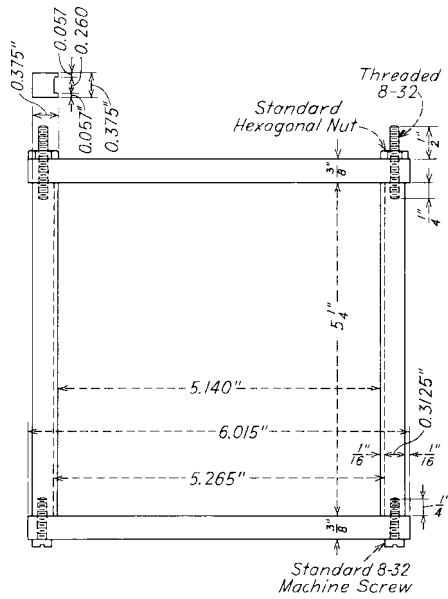

Metric Equivalents

| in. | mm |
|--------|-------|
| 0.057 | 1.4 |
| 1/16 | 1.6 |
| 1/4 | 6.4 |
| 0.260 | 6.6 |
| 0.3125 | 7.938 |
| 0.375 | 9.53 |
| 3/8 | 9.5 |
| 1/2 | 12.7 |
| 5.140 | 130.6 |
| 5 1/4 | 133.4 |
| 5.265 | 133.7 |
| 6.015 | 152.9 |

FIG. 1 Specimen Holder

have been removed from the cut edges. Sand, mill or lathe-cut the exposed cut surfaces if necessary, taking care that the resin content or other characteristics of the material are not affected.

8. Conditioning

8.1 Condition the mounted strips for 48 h at 50 ± 3°C. Allow to cool in a desiccator for at least 1 h, or sufficient time to bring the assembly to room temperature. Other conditioning procedures may be employed as agreed upon between all the parties concerned.

9. Procedure

9.1 Apply the foil electrodes to each side of the test specimen using a thin film of petrolatum as an adhesive, making certain that the electrodes are centered on the specimen and with respect to each other. Eliminate any air gaps under the foil by smoothing the electrode and pressing with a suitable roller or soft cloth.

9.2 **Warning**—Lethal voltages may be present during this test. It is essential that the test apparatus and all associated

equipment that may be electrically connected to it be properly designed and installed for safe operation. Solidly ground all metal parts that any person might come into contact with during the test. Thoroughly instruct all operators in the proper way to conduct the test safely. When making high voltage tests, particularly in compressed gas or in oil, the energy released at breakdown may be sufficient to result in fire, explosion, or rupture of the test chamber. Design of test equipment, test chambers and test specimens should be such as to minimize the possibility of such occurrences, and to eliminate the possibility of personal injury.

9.3 Measure the ac capacitance and dissipation factor of the test specimens cut in the lengthwise and crosswise directions, at a specified frequency and temperature using the procedures described in Test Methods D 150. Record the applied voltage, the effective voltage gradient and the diameter of the electrodes used. Calculate the loss index and permittivity.

9.4 For accuracy in the calculation of permittivity, where the surfaces have not been sanded, milled, or lathe-turned after assembly in the frame, measure the thickness of the individual strips in a direction parallel with the laminations and average these to obtain the specimen thickness.

10. Report

- 10.1 Report the following information:
 - 10.1.1 A description of the material by name, grade, color and manufacturer,
 - 10.1.2 The frequency of the measurement,
 - 10.1.3 The temperature and relative humidity during the measurement,
 - 10.1.4 Conditioning of the specimen, if different than specified in Section 8,
 - 10.1.5 The voltage gradient across the electrodes,
 - 10.1.6 The measured capacitance of each specimen in picofarads,
 - 10.1.7 The effective area of the electrodes for each test,
 - 10.1.8 The average thickness of each specimen,
 - 10.1.9 The type of measurement circuit or equipment used, and
 - 10.1.10 The dissipation factor, permittivity, and loss index for the lengthwise and crosswise specimens.

11. Precision and Bias

11.1 *Precision*—This method has been in use for many years, but no statement of precision has been available and no activity is planned to develop such a statement.

11.2 *Bias*—A statement of bias is not applicable in view of the unavailability of a standard reference material for this property.

12. Keywords

12.1 dissipation factor (parallel); permittivity (parallel); rigid plates; rigid sheets; thermosetting laminates

 **D 669**

The American Society for Testing and Materials takes no position respecting the validity of any patent rights asserted in connection with any item mentioned in this standard. Users of this standard are expressly advised that determination of the validity of any such patent rights, and the risk of infringement of such rights, are entirely their own responsibility.

This standard is subject to revision at any time by the responsible technical committee and must be reviewed every five years and if not revised, either reapproved or withdrawn. Your comments are invited either for revision of this standard or for additional standards and should be addressed to ASTM Headquarters. Your comments will receive careful consideration at a meeting of the responsible technical committee, which you may attend. If you feel that your comments have not received a fair hearing you should make your views known to the ASTM Committee on Standards, at the address shown below.

This standard is copyrighted by ASTM, 100 Barr Harbor Drive, PO Box C700, West Conshohocken, PA 19428-2959, United States. Individual reprints (single or multiple copies) of this standard may be obtained by contacting ASTM at the above address or at 610-832-9585 (phone), 610-832-9555 (fax), or service@astm.org (e-mail); or through the ASTM website (www.astm.org).