



Designation: D 178 – 01

## Standard Specification for Rubber Insulating Matting<sup>1</sup>

This standard is issued under the fixed designation D 178; the number immediately following the designation indicates the year of original adoption or, in the case of revision, the year of last revision. A number in parentheses indicates the year of last approval. A superscript epsilon ( $\epsilon$ ) indicates an editorial change since the last revision or reapproval.

*This standard has been approved for use by agencies of the Department of Defense.*

### 1. Scope

1.1 This specification covers acceptance testing of rubber insulating matting for use as a floor covering for protection of workers.

1.2 Two types of matting, differing in chemical and physical characteristics, are provided and are designated as Type I and Type II matting.

1.3 The following safety hazards caveat applies only to the test method portion, Sections 17 to 19, of this specification: *This standard does not purport to address all of the safety concerns, if any, associated with its use. It is the responsibility of the user of this standard to establish appropriate safety and health practices and determine the applicability of regulatory limitations prior to use.*

NOTE 1—Rubber insulating matting should remain flexible for use through normal temperature ranges.

NOTE 2—Rubber as used in this specification is a generic term that includes elastomers and elastomer compounds, regardless of origin.

### 2. Referenced Documents

#### 2.1 ASTM Standards:

- D 149 Test Method for Dielectric Breakdown Voltage and Dielectric Strength of Solid Electrical Insulating Materials at Commercial Power Frequencies<sup>2</sup>
- D 297 Test Methods for Rubber Products—Chemical Analysis<sup>3</sup>
- D 412 Test Methods for Vulcanized Rubber and Thermoplastic Rubbers and Thermoplastic Elastomers—Tension<sup>3</sup>
- D 471 Test Method for Rubber Property—Effect of Liquids<sup>3</sup>
- D 518 Test Method for Rubber Deterioration—Surface Cracking<sup>3</sup>

<sup>1</sup> This specification is under the jurisdiction of ASTM Committee F18 on Electrical Protective Equipment for Workers and is the direct responsibility of Subcommittee F18.25 on Insulating Cover-Up Equipment. This standard replaces ANSI Standard J 6.7, which is no longer available.

Current edition approved March 10, 2001. Published May 2001. Originally published as D178 – 23 T. Last previous edition D178 – 93 (1998).

<sup>2</sup> Annual Book of ASTM Standards, Vol 10.01.

<sup>3</sup> Annual Book of ASTM Standards, Vol 09.01.

D 570 Test Method for Water Absorption of Plastics<sup>4</sup>

D 573 Test Method for Rubber Deterioration in an Air Oven<sup>3</sup>

D 1692 Test Method for Rate of Burning or Extent and Time of Burning of Cellular Plastics Using a Specimen Supported by a Horizontal Screen<sup>5</sup>

2.2 American National Standard.<sup>6</sup>

ANSI C84.1 Voltage Ratings for Electric Power Systems and Equipment (60 Hz)

### 3. Terminology

#### 3.1 Definitions:

3.1.1 *user, n*—as used in 4.3.1, the entity employing the actual worker(s) utilizing the equipment; if no separate employer, then the individual.

3.1.2 *voltage, maximum retest, n*—voltage, either ac rms or dc avg, which is equal to the proof-test voltage for new protective equipment.

3.1.3 *voltage, retest, n*—voltage, either ac rms or dc avg, that used protective equipment must be capable of withstanding for a specified test period without breakdown.

3.1.4 *voltage, nominal design, n*—a nominal value consistent with the latest revision of ANSI C84.1, assigned to the circuit or system for the purpose of conveniently designating its voltage class.

3.1.5 *voltage, maximum use, n*—the ac voltage (rms) classification of the protective equipment that designates the maximum nominal design voltage of the energized system that may be safely worked. The nominal design voltage is equal to phase-to-phase voltage on multiphase circuits.

3.1.5.1 If there is no multiphase exposure in a system area, and the voltage exposure is limited to phase (polarity on dc systems) to ground potential, the phase (polarity on dc systems) to ground potential shall be considered to be the nominal design voltage.

<sup>4</sup> Annual Book of ASTM Standards, Vol 08.01.

<sup>5</sup> Discontinued January 1978; see the 1977 Annual Book of ASTM Standards, Part 36.

<sup>6</sup> Available from American National Standards Institute, 11 West 42nd Street, 13th Floor, New York, NY 10036.

3.1.5.2 If electrical equipment and devices are insulated, or isolated, or both, such that the multiphase exposure on a grounded wye circuit is removed, then the nominal design voltage may be considered as the phase-to-ground voltage on that circuit.

#### 4. Significance and Use

4.1 This specification covers the minimum electrical, chemical, and physical properties guaranteed by the manufacturer and the detailed procedures by which such properties are to be determined. The purchaser may at his option perform or have performed any of these tests in order to verify the guarantee. Claims for failure to meet the specification are subject to verification by the manufacturer.

4.2 Rubber insulating matting is used for personal protection; therefore when authorizing its use a margin of safety should be allowed between the maximum voltage at which it is used and the proof-test voltage at which it is tested. The relationship between proof-test and the maximum voltage at which matting shall be used is shown in Table 1.

4.3 Work practices vary from user to user, depending upon many factors. These may include, but are not limited to, operating system voltages, construction design, work procedures and techniques, weather conditions etc. Therefore, except for the restrictions set forth in this specification because of design limitations, the use and maintenance of this equipment is beyond the scope of this specification

4.3.1 It is common practice and the responsibility of the user of this type of protective equipment to prepare complete instructions and regulations to govern the correct and safe use of such equipment.

#### 5. Classification

5.1 Matting covered under this specification shall be designated as Type I or Type II; Class 0, Class 1, Class 2, Class 3, or Class 4.

5.1.1 *Type I*, made of any elastomer or combination of elastomer compounds, properly vulcanized.

5.1.2 *Type II*, made of any elastomer or combination of elastomeric compounds with one or more of the following special properties:

5.1.2.1 *A*—Ozone resistance

5.1.2.2 *B*—Flame resistance

5.1.2.3 *C*—Oil resistance

5.1.3 The class designation shall be based on the electrical properties as shown in Table 2.

#### 6. Ordering Information

6.1 Orders for matting under this specification should include the following information:

6.1.1 Type,

6.1.2 Class,

6.1.3 Thickness,

6.1.4 Width,

6.1.5 Length, and

6.1.6 Color.

6.2 The listing of types, classes, thicknesses, widths, lengths, and colors is not intended to mean that all shall necessarily be available from manufacturers; it signifies only that, if made, they shall conform to the details of this specification.

#### 7. Manufacture and Marking

7.1 The matting shall consist of a rubber compound with a smooth, corrugated, or diamond design on one surface and may be backed with fabric, or may have one or more fabric inserts. The back of the matting may be finished with cloth imprint or other slip-resistant material. Any such fabric insert shall not affect adversely the dielectric characteristics of the matting.

7.2 Each piece of matting shall be marked clearly and permanently at a maximum interval of 1 m (3 ft) with the name of the manufacturer or supplier, ASTM D178, type, and class.

#### 8. Dimensions and Permissible Variations

8.1 *Width*—Standard widths shall be  $610 \pm 13$  mm ( $24.0 \pm 0.5$  in.),  $760 \pm 13$  mm ( $30.0 \pm 0.5$  in.),  $914 \pm 25$  mm ( $36 \pm 1$  in.) and  $1220 \pm 25$  mm ( $48 \pm 1$  in.).

8.2 *Thickness*—The thickness of the matting shall be as specified in Table 3. Measurements shall be made over the corrugations or diamonds. The corrugations shall be not more than 3.2 mm (0.125 in.) deep. The diamonds shall not be higher than 1.6 mm (0.062 in.).

#### 9. Workmanship and Finish

9.1 The matting shall be free of harmful physical irregularities, which can be detected by thorough test or inspection.

9.1.1 *Nonharmful Irregularities*—Surface irregularities may be present on all rubber matting due to imperfections in molds and inherent difficulties in the manufacturing processes. These irregularities may appear as indentations, protuberances, or imbedded foreign material that are acceptable provided that:

9.1.1.1 The indentation or protuberance tends to blend into a smooth slope upon stretching of the material.

9.1.1.2 The rubber thickness at any irregularity conforms to the thickness requirements.

9.1.1.3 Foreign material remains in place when the matting is bent and stretches equally with the material surrounding it.

**TABLE 1 Proof Test/Use Voltage Relationship**

NOTE 1—The ac voltage (rms) classification of the protective equipment designates the maximum nominal design voltage of the energized system that may be safely worked. The nominal design voltage is equal to:

a. The phase to phase on multiphase circuits or

b. The phase to ground voltage on single phase grounded circuits.

Class of Insulating Matting	Nominal Maximum Use Voltage <sup>A</sup> Phase-Phase ac rms, max	AC Proof-Test Voltage, rms V	DC Proof-Test Voltage, avg, V
0	1 000	5 000	20 000
1	7 500	10 000	40 000
2	17 000	20 000	50 000
3	26 500	30 000	60 000
4	36 000	40 000	70 000

<sup>A</sup>Except for Class O equipment, the maximum use voltage is based on the following formula:

Maximum use voltage (maximum nominal design voltage) 0.95 ac proof-test voltage - 2000

**TABLE 2 Electrical Test Requirements**

Class	AC			Dielectric Test Voltage	DC <sup>A</sup>			
	Electrode Clearances, min <sup>B</sup>		Proof Test Voltage		Electrode Clearances, min <sup>B</sup>	Proof Test Voltage	Dielectric Test Voltage	
	mm	in.					rms V	mm
0	76	3	5 000	6 000	76	3	20 000	35 000
1	76	3	10 000	20 000	76	3	40 000	60 000
2	127	5	20 000	30 000	152	6	50 000	70 000
3	178	7	30 000	40 000	203	8	60 000	80 000
4	178	10	40 000	50 000	305	12	70 000	90 000

<sup>A</sup>DC proof-test, voltages were determined using negative polarity.

<sup>B</sup>These nominal clearances are intended to avoid flashover and may be increased by no more than 2 in. (51 mm) when required by change in atmospheric conditions from the standard of 100 kPa (1 atm) barometric pressure and average humidity conditions. These clearances may be decreased if atmospheric conditions permit.

**TABLE 3 Thickness Measurements**

Class	Thickness		Tolerance	
	mm	in.	mm	in.
0	3.2	0.13	0.8	0.03
1	4.8	0.19	0.8	0.03
2	6.4	0.25	0.8	0.03
3	9.5	0.38	1.2	0.05
4	12.7	0.50	1.2	0.05

## 10. Chemical and Physical Requirements

10.1 Insulating matting shall conform to the physical requirements in Table 4. For Type II matting, flame or oil resistance can be determined by conducting the tests in 19.2.5 or 19.2.6, respectively.

## 11. Electrical Requirements

11.1 The entire length of each roll of matting when new (unused) shall withstand the 60-Hz ac proof-test voltage (rms value) or the dc proof-test voltage (average value) specified in Table 2. The test voltage shall be applied continuously for 1 min.

11.2 The matting material when tested between 50-mm (2-in.) disk electrodes with edges rounded to a radius of 6 mm (0.25 in.), shall show a 60-Hz dielectric strength of not less than the requirements shown in Table 2 for the thickness of each individual specimen.

11.3 The Type IIA matting material shall show no visible effects from ozone when tested in accordance with 18.6.1, or 18.6.2. In case of dispute, Method A of the ozone resistance test shall be the referee test.

**TABLE 4 Physical Requirements**

	Type I	Type II
Tensile strength, min, MPa (psi)	4.83 (700)	4.83 (700)
Tension set, max, at 150 % elongation, 51-mm (2-in.) bench mark, mm (in.)	12.7 (0.50)	12.7 (0.50)
Elongation, min, %	250	250
Moisture absorption, max in-crease <sup>A</sup> , %	1½	3
Flame resistance, Type IIB	not applicable	12.7 mm (0.5 in.) after 30 s
Oil resistance, max, volume increase, Type IIC <sup>B</sup>	not applicable	4

<sup>A</sup>Distilled water—23°C (75°F).

<sup>B</sup>ASTM Oil No. 2 room temperature for 24 h.

## 12. Guarantee

12.1 The manufacturer or supplier shall replace, without charge to the purchaser, unused matting which, at any time within a period of nine (9) months from date of initial delivery of shipment to the purchaser or his designee, fail to pass the tests in this specification. This guarantee will be binding on the manufacturer or supplier only if the matting has been properly stored and has not been subjected to more than an original acceptance test and one retest.

12.2 Any acceptance test made by the purchaser, or the purchaser's designee, shall be performed within the first two (2) months of the guarantee period unless otherwise specified.

NOTE 3—Proper storage means that the matting is stored without distortion, and not stored directly above or in proximity to steam pipes, radiators, or other sources of artificial heat, or exposed to direct sunlight or sources of ozone. It is desirable that the ambient storage temperature shall not exceed 35°C (95°F).

## 13. Sampling

13.1 Each roll of matting in a lot or shipment shall be subject to inspection and test by the manufacturer including electrical proof test to levels required in Table 2 of this specification.

13.2 An original sample of sufficient material shall be cut from the end of a roll or rolls selected from the lot for the test requirements of Section 10, 11.2, and 11.3. A lot is defined as that quantity of material produced by a common manufacturing process during a consecutive time period not to exceed 24 h. If failure occurs in the first sample, a second sample of the same quantity shall be selected and tested.

## 14. Rejection

14.1 Individual rolls shall be rejected if they fail to meet the manufacturing and marking requirements of Section 7, the electrical requirements of 11.1, the width requirements of 8.1, the minimum thickness requirements of 8.2, or the workmanship requirements of Section 9.

14.2 The entire lot or shipment of matting shall be rejected under any of the following conditions:

14.2.1 If 5 % or more, but not less than two rolls of the matting, in a shipment fail to meet the requirements of 11.1.

14.2.2 If two dielectric breakdowns that do not meet the dielectric strength value specified in 11.2 occur in five tests on the specimen.

14.2.3 If one dielectric breakdown of five tests on the original and one or more dielectric breakdowns of five tests on an additional specimen fail to meet the dielectric strength value specified in 11.2.

14.2.4 If the sample specimens of Type IIA matting, using the sampling methods and criteria specified in 18.6.1 or 18.6.2, fail to meet the ozone resistance requirements of 11.3.

14.2.5 If the sample specimens of Type IIB matting using the sampling methods and criteria specified in 19.2.5, fail to meet the flame-resistant requirements of 10.1.

14.2.6 If the sample specimens of Type IIC matting using the sampling methods and criteria specified in 19.2.6 fail to meet the oil resistance requirements of 10.1.

14.3 The testing shall be terminated and the manufacturer or supplier notified if, during the course of testing, 5 % or more, but not less than two rolls, of the matting in a lot or shipment, fail to meet the requirements of 11.1, 11.2, or 11.3 as determined by the rejection criteria of 14.1, 14.2, 14.2.1, 14.2.2, 14.2.3, 14.2.4, 14.2.5, or 14.2.6. The manufacturer or supplier may in such a case require the purchaser to submit proof that the test procedure and equipment conform to the appropriate paragraphs of Section 18. When such proof has been furnished, the manufacturer or supplier may request that his representative witness the testing of additional rolls from the shipment.

14.4 The entire lot or shipment of matting may be rejected at the option of the purchaser if two of the five specimens tested fail any of the separate requirements outlined in Section 10.

14.5 The entire lot or shipment of matting may be rejected at the option of the purchaser if 25 % of the matting in the lot or shipment fail to meet the requirements of Section 8 or 9.

14.6 All rejected material shall be returned unaltered except as required for sampling, as directed by the manufacturer at his or the supplier's request. However, those mats punctured when tested in accordance with 11.1 or 11.2 shall be stamped, punched, or cut prior to being returned to the supplier to indicate that they are unfit for electrical use.

## 15. Packaging

15.1 Matting shall be packaged either flat or in rolls and shall not be distorted mechanically.

## 16. Thickness Measurements

16.1 Thickness measurements should be made on complete matting samples with a caliper graduated to within 0.03 mm (0.001 in.). At least five thickness measurements shall be made at selected points uniformly distributed over the test area of the matting.

## TEST METHODS

### 17. Sequence of Testing

17.1 The following order of procedure is suggested for testing rubber insulating matting.

17.1.1 Inspection of the surfaces in accordance with Section 9.

17.1.2 The dimensions in accordance with Sections 8 and 16.

17.1.3 Electrical proof test in accordance with the appropriate paragraphs of Section 18.

17.1.4 Breakdown voltage test in accordance with the appropriate paragraphs of Section 18.

17.1.5 Ozone resistance tests in accordance with the appropriate paragraphs of Section 18.

17.1.6 Chemical and physical property tests in accordance with Section 19.

## 18. Electrical Tests

18.1 *Conditioning*—Prior to testing, the matting shall be made in a flat position.

NOTE 4—Both ac and dc proof-test methods are included in this section. It is intended that one method be selected for the electrical acceptance tests. The method selected shall be at the option of the purchaser, and the supplier should be so notified of the selection.

18.2 **Warning:** It is recommended that the test apparatus be designed to afford the operator full protection in the performance of his duties. Reliable means of de-energizing and grounding the high-voltage circuit should be provided. It is particularly important to incorporate a positive means of grounding the high-voltage section of dc test apparatus due to the likely presence of high-voltage capacitance charges at the conclusion of the test.

### 18.3 AC Proof Test:

18.3.1 *Electrodes*—Where electrodes are to be employed as part of the test apparatus, they shall be of such design so as to apply the electrical stress uniformly over the test area without producing corona at any point, or mechanical strain in the material. The electrodes used in proof tests shall be of such dimensions that the flashover clearances specified in Table 2 are not exceeded. A satisfactory procedure for ac proof testing utilizes electrodes that will provide intimate contact without undue pressure.

NOTE 5—Rectangular metal sheets approximately 3 mm (0.06 in.) thick, having smoothly rounded edges and corners, have been found to be satisfactory for this purpose. Also satisfactory are wet felt or sponge-top electrodes.

### 18.3.2 Voltage Supply and Regulation:

18.3.2.1 The test equipment used in both the proof-test voltage and dielectric breakdown voltage tests shall be capable of supplying an essentially stepless and continuously variable voltage to the test specimen. Motor-driven regulating equipment is convenient and tends to provide uniform rate-of-rise to the test voltage. The test apparatus should be protected by an automatic circuit-breaking device designed to open promptly on the current produced by breakdown of a specimen under test. This circuit breaking device should be designed to protect the test equipment under any conditions of short circuit.

18.3.2.2 The desired test voltage may be obtained most readily from a step-up transformer energized from a variable low-voltage source. The transformer and its control equipment shall be of such size and design that, with the test specimen in the circuit, the crest factor (ratio of maximum to mean effective) of the test voltage shall differ by not more than 5 % from that of a sinusoidal wave over the upper half of the range of test voltage.

18.3.2.3 The accuracy of the voltage-measuring circuit shall be within  $\pm 2\%$  of full scale. The correct rms value of the actual sinusoidal voltage wave-form applied to the matting may be measured by one of the following methods: (1) a voltmeter used in conjunction with a calibrated instrument transformer connected directly across the high-voltage circuit, (2) a calibrated electrostatic voltmeter connected directly across the high-voltage circuit, or (3) an ac meter connected in series with appropriate high-voltage type resistors directly across the high-voltage circuit.

18.3.2.4 The crest factor may be checked by the use of a peak-reading voltmeter connected directly across the high-voltage circuit. If an electrostatic voltmeter or an rms voltmeter in conjunction with an instrument potential transformer is connected across the high-voltage circuit, a standard sphere gap may be sparked over and the corresponding voltage compared with the reading of the rms voltmeter.

18.3.3 *Test*—The proof-test voltage shall be initially applied at a low value and then gradually increased at a constant rate-of-rise of approximately 1000 V/s ac until the prescribed test voltage level is reached, or failure occurs. The test period starts at the instant that the prescribed testing voltage is reached. Reduce the applied voltage to at least half value, unless an electrical puncture has already occurred, at the end of the test period before opening the test circuit.

#### 18.4 *DC Proof Test:*

18.4.1 *Electrodes*—The dc proof-test may be made with dry electrodes that consist of two flat metallic plates, at least one of which is sized so that the flashover distances recommended in Table 2 are not exceeded. The edges of these plates should be rounded so as to eliminate sharp nicks and protuberances.

#### 18.4.2 *Voltage Supply and Regulation:*

18.4.2.1 The dc proof-test voltage shall be obtained from a dc source capable of supplying the required voltage. The peak-to-peak ac ripple component of the dc proof-test voltage shall not exceed 2% of the average voltage value under no-load conditions.

18.4.2.2 The dc proof-test voltage shall be measured by a method that provides the average value of the voltage applied to the matting. It is recommended that the voltage be measured by the use of a dc meter connected in series with appropriate high-voltage type resistors across the high-voltage circuit. An electrostatic voltmeter of proper range may be used in place of the dc meter-resistor combination. The accuracy of the voltage measuring circuit shall be within  $\pm 2\%$  of full scale.

18.4.3 *Procedure*—The procedure shall be the same as the ac proof test, except that the rate-of-rise shall be approximately 3000 V/s dc.

18.5 *Dielectric Breakdown Test*—The dielectric breakdown test shall be performed in accordance with Test Method D 149. The voltage should be applied at the rate of 3000 V/s under the short-time procedure. The specimen shall be representative of the matting material to be tested. Sufficient material shall be available to permit making five tests.

18.6 *Ozone Resistance Test*—The ozone resistance test shall be made in accordance with one of the following methods to ensure conformance of Type IIA matting with the requirements of 11.3:

18.6.1 *Method A*—The ozone resistance test shall be made in accordance with Procedure A of Test Method D 518. Cut the specimen to a 10 by 100-mm (0.5 by 4-in.) rectangular size. A temperature of 40°C (104°F) shall be maintained. Procedure A shall be followed using a 20% extension. The ozone concentration shall be maintained at  $500 \pm 50 \text{ mm}^3/\text{m}^3$  ( $50 \pm 5$  ppm) by volume for a 3-h test period. Type II matting shall show no effect from ozone exposure during this test period.

18.6.2 *Method B*—The ozone resistance test shall be made on a 100 by 150-mm (4 by 6-in.) specimen of the matting material prepared from a sample suitably conditioned by lying flat for 24 h. The specimen should be draped over a 25-mm (1-in.) diameter metal tube of sufficient length to completely underlie the specimen, while possessing additional length for the required mounting support. The metal tubing is electrically grounded. The free ends of the specimen shall be clamped beneath the tubing electrode so that an intimate contact is established between the specimen and the tubing along the upper half of the cylindrically-shaped electrode surface. A piece of flat aluminum sheet foil, approximately 50 by 100 mm (2 by 4 in.), shall be placed over the draped specimen so as to provide adequate separation distance to prevent flashover between the foil and the metal tubing. An electrode wire shall be connected to the aluminum foil.

18.6.2.1 The outer electrode (metal foil) shall be energized to approximately 15 kV ac (rms) from a stable 60-Hz source. The 15 kV potential may be derived from a suitably rated potential transformer energized from its low-voltage winding through a continuously variable autotransformer. An overcurrent protective device should be incorporated into the low-voltage control circuit in case of an electrical breakdown.

18.6.2.2 The ozone resistance of the specimen should be determined qualitatively, by inspection, after a 1-h exposure period in the test apparatus at the 15 kV potential. Any visible signs of ozone deterioration of the matting material such as checking, cracking, breaks, pitting, etc., shall be considered as evidence of failure to meet the requirements of Type IIA matting. At least two specimens from each sample of matting selected in accordance with 12.2 shall be tested. Two specimens should not be taken from the same section of the sample matting.

NOTE 6—The rate of ozone degradation by use of Method B is inversely proportional to the relative humidity of the surrounding air. Empirical data indicate, however, that visible ozone effects will be evident over a broad range of ambient humidities under these test conditions.

## 19. Chemical and Physical Tests

19.1 *Chemical Tests*—The composition of the rubber hydrocarbon portion of Type I matting may be determined using the test methods in Test Methods D 297, or the manufacturer's formulation processes may be certified by appropriate personnel.

#### 19.2 *Physical Tests:*

19.2.1 Physical tests should be performed to determine the physical requirements specified in Section 8. The matting samples should be conditioned by storing in a flat position for 24 h at room temperature.

19.2.2 The tensile strength, elongation, and tension set tests shall be performed in accordance with Test Methods D 412.

The tensile strength and elongation specimens shall conform in dimensions to Die C. The tensile set specimens shall conform to Die B. The elongation in the tensile set shall be as specified in Table 4.

19.2.3 The moisture absorption tests shall be performed in accordance with Test Method D 570, using the 24-h immersion procedure at a temperature of 23°C (75°F).

19.2.4 The accelerated aging tests shall be performed in accordance with Test Method D 573. After being subjected to

a temperature of  $70 \pm 1^\circ\text{C}$  ( $158 \pm 2^\circ\text{F}$ ) in circulating air for 7 days, the tensile strength of the specimen shall not be less than 50 % of the original.

19.2.5 The flame resistance tests called for in Type IIB shall be performed in accordance with Test Method D 1692, with the maximum limits conforming to the requirements of classification SE (Self-Extinguishing).

19.2.6 The oil resistance tests called for in Type IIC shall be performed in accordance with Test Method D 471.

## APPENDIX

### (Nonmandatory Information)

#### X1. TEST METHOD FOR RATE, EXTENT, OR TIME, OR A COMBINATION THEREOF, OF BURNING OF CELLULAR PLASTICS USING A SPECIMEN SUPPORTED BY A HORIZONTAL SCREEN

##### X1.1 Scope

X1.1.1 This test method covers a small-scale horizontal laboratory screening procedure for measuring the rate, extent, or time, or a combination thereof, of burning of rigid or flexible cellular plastics in accordance with this test procedure.

X1.1.2 Materials that exhibit pronounced shrinking, curling, or melting away upon heating cannot be evaluated by this test method.

X1.1.3 This test method is not applicable to materials that cannot be ignited under the conditions of this test, or to materials that exhibit progressive combustion without flame (continued glowing or charring).

NOTE X1.1—The rate of burning or extent of burning of rigid cellular plastics also may be determined by Test Method D 3014 where the specimen is supported vertically.

NOTE X1.2—**Caution:** During the course of combustion, gases or vapors, are evolved that may be hazardous to personnel. Adequate precautions should be taken to protect the operator.

X1.1.4 *This standard does not purport to address all of the safety concerns, if any, associated with its use. It is the responsibility of the user of this standard to establish appropriate safety and health practices and determine the applicability of regulatory limitations prior to use.*

##### X1.2 Referenced Documents

###### X1.2.1 ASTM Standards:

D 1564 Testing Flexible Cellular Materials—Slab Urethane Insulating Oils<sup>7</sup>

D 1565 Specification for Flexible Cellular Materials—Vinyl Chloride Polymers and Copolymers (Open-Cell Foam)<sup>8</sup>

D 2406 Methods of Testing Flexible Cellular Materials Molded Urethane Foam<sup>9</sup>

D 3014 Test Method for Flame Height, Time of Burning, and Loss of Mass of Rigid Thermoset Cellular Plastics in

a Vertical Position<sup>10</sup>

##### X1.3 Significance and Use

X1.3.1 Tests made on a cellular plastic under conditions herein prescribed can be of considerable value in comparing the rate of burning and/or extent and time of burning of different materials, in controlling manufacturing processes, or as a measure of deterioration or change in burning characteristics prior to or during use.

X1.3.2 This test method is not intended to be a criterion for fire hazard. The fire hazard created by materials depends upon the form and end use of the material. Assessment of fire hazard includes, but is not limited to, many factors, such as, ease of ignition, burning rate, flame spread, fuel contribution, intensity of burning, and products of combustion.

##### X1.4 Apparatus

X1.4.1 *Test Chamber*—Any enclosure is satisfactory that is large enough to provide quiet, draft-free air surrounding the specimen during the test, yet will permit normal thermal circulation of air past the specimen during burning. A hood is recommended in order to remove the sometimes noxious products of combustion. If a test chamber is used. It should be of such a design that it can be used in a hood. For referee purposes, test results with the chamber should be the same whether or not the hood exhaust is on. In cases of discrepancy, values obtained with the damper closed or the hood fan off, or both, will be considered valid.

X1.4.1.1 The recommended test chamber should be constructed of sheet metal or other fire-resistant material, having inside dimensions 300 mm wide, 600 mm long, and 760 mm high, open at the top, with a ventilating opening approximately 25 mm high around the bottom. A viewing window of heat-resistant glass should be of sufficient size and in such a position that the entire length of the specimen under test may be observed. The chamber should be opened readily and closed to facilitate mounting and ignition of the test specimen.

<sup>7</sup> Discontinued 1979; Replaced by D 3574.

<sup>8</sup> Discontinued 1998; See *Annual Book of ASTM Standards*, Vol 08.01.

<sup>9</sup> Discontinued 1980; Replaced by D 3574.

<sup>10</sup> *Annual Book of ASTM Standards*, Vol 08.02.

X1.4.2 *Burner*—A standard  $9.5 \pm 0.5$ -mm outside diameter barrel bunsen or Tirrill burner fitted with a  $48 \pm 1$ -mm width wing top.

NOTE X1.3—The wing top may have to be opened to approximately  $3 \pm 0.1$  mm to provide the flame required in X1.6.4.

X1.4.3 *Fuel Supply*—Propane gas of at least 85 % purity.

X1.4.4 *Specimen Support*—Wire cloth (wire screen)<sup>11</sup> 6.5-mm mesh using 0.8-mm diameter steel wire. The wire cloth specimen support 75 by 215 mm shall have a  $15 \pm 1$  mm of length bent to form a right angle. This will form the specimen support as shown in Fig. X1.1 and Fig. X1.2.

X1.4.5 *Specimen Support Holders*—Any holding device that will clamp the wire cloth specimen support horizontally so that the bottom of the bent-up portion is  $13 \pm 1$ -mm above the top of the burner wing top, as shown in Fig. X1.1. A typical arrangement consists of two laboratory ring stands with two adjustable flat-surface clamps, which may be locked in place by set screw and lock nut. See Fig. X1.2 and Fig. X1.3.

X1.4.6 *Sheet of Asbestos Board*, 250 by 250 by 6.5 mm shall be placed on the bottom of the test chamber.

X1.4.7 *Aluminum Foil*.

X1.4.8 *Timing Device*, accurate to  $\pm 1$  s.

X1.4.9 *Measuring Scale*, graduated in at least 2.0-mm intervals.

X1.4.10 A device to ensure correct relative positioning of burner and specimen.

### X1.5 Test Specimen

X1.5.1 Five specimens  $50 \pm 0.25$  mm wide by  $150 \pm 1$  mm long are needed.

X1.5.1.1 Specimens shall be cut from representative material. Materials supplied in thicknesses over 13 mm shall be cut to 13 mm thickness. Materials formed in thicknesses of 13 mm or less shall be tested at the thickness supplied.

X1.5.1.2 Materials with directional effects such as skin or inserts shall be oriented so as to provide the most adverse results.

<sup>11</sup> Stainless-steel wire cloth can be obtained from Cleveland Wire Cloth and Mfg. Co., 3573 E. 78<sup>th</sup> Street, Cleveland, OH 44105.

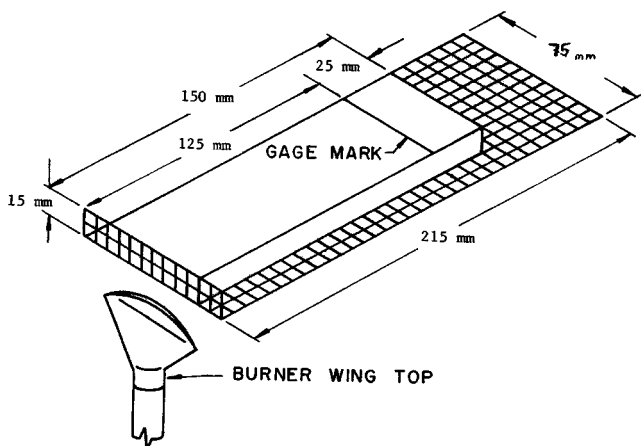

FIG. X1.1 Relative Position of Burner Wing Top, Specimen, and Specimen Support

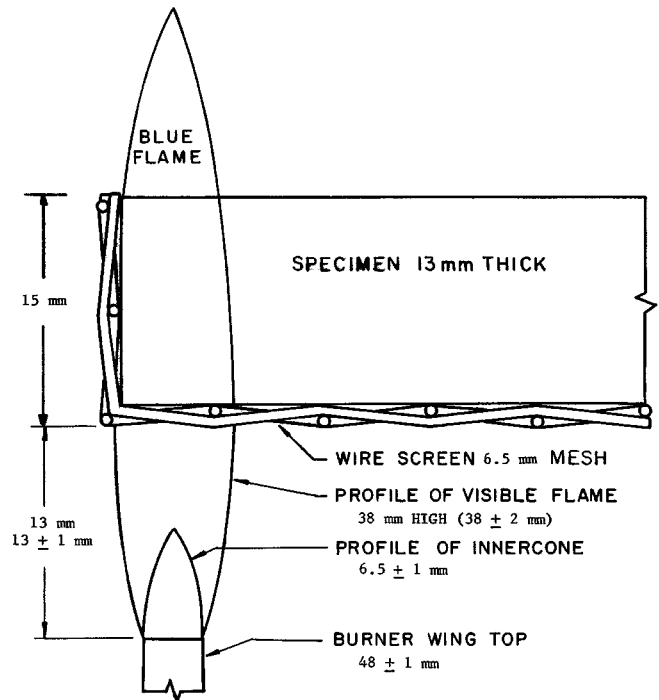

FIG. X1.2 Relative Position of Burner Wing Top, Flame, Specimen, and Specimen Support

X1.5.1.3 Sheet samples shall be cut from a thickness of sheet normally supplied or molded to a desired thickness.

X1.5.1.4 Molded expanded or sponge materials not conforming to the width requirements in X1.4.1 shall be tested as agreed upon between manufacturer and purchaser.

X1.5.1.5 Each test specimen shall be marked across its width by one line 125 mm from one end.

### X1.6 Conditioning

X1.6.1 Specimens shall be conditioned prior to test for a minimum of 24 h in an atmosphere having a temperature of  $23 \pm 2^\circ\text{C}$  and a relative humidity of  $50 \pm 5\%$ . Tests shall be made in this atmosphere or immediately after removal therefrom.

### X1.7 Procedure

X1.7.1 Determine the density according to the proper test method for the type of material being evaluated. The test can be made in accordance with Test Methods D 1564, D 1565, D 2406, or a test method agreed upon between the purchaser and the seller.

X1.7.2 Clamp the wire cloth specimen support horizontally so that the bottom of the wire cloth is  $13 \pm 1$  mm above the top of the burner wing top as shown in Fig. X1.1. Cover the sheet of asbestos board with a layer of aluminum foil and place it on the bottom of the test chamber to catch any dripping or flaming particles. The distance between the wire cloth and the foil shall be between 150 to 200 mm. Change the foil after each test, if there is any debris on the surface from the previous determination. Burn off any material remaining on the wire cloth from the previous tests, or use a new wire cloth for each test. If a new wire cloth is not used for each test, the wire cloth should

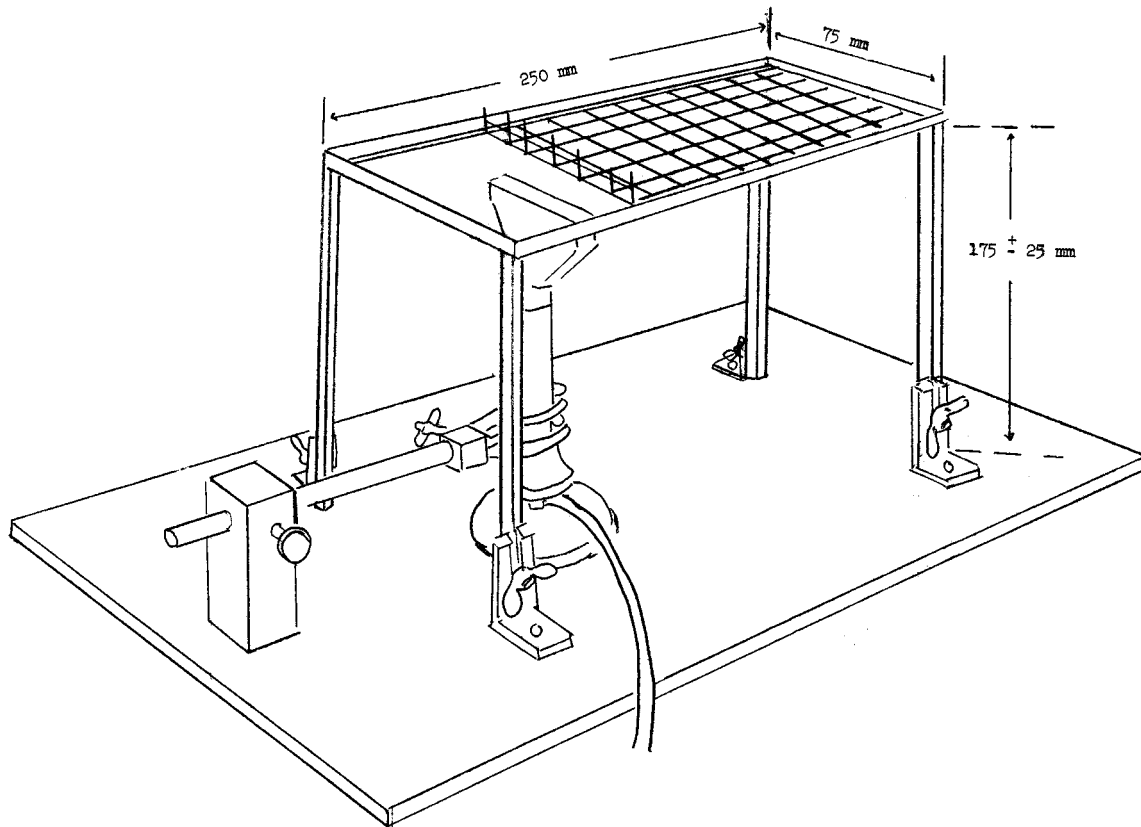

**FIG. X1.3 Apparatus for Support of Specimen**

be cool to the touch before being used. If dripping or melting material fall into the wing top clean it before testing the next specimen.

X1.7.3 Place the specimen on the support with one end touching the 15 mm bent-up portion of the support. The end of the specimen nearest the gage mark should be away from the bent-up end of the specimen support, so that the gage mark is 125 mm away from the bent-up end. See Fig. X1.1.

X1.7.4 Adjust the burner with the wing top to provide a blue flame whose visible portion is  $38 \pm 2$  mm high with a clearly defined inner cone  $6.5 \pm 1.0$  mm high. Place the burner under the upturned end of the specimen support so that one edge of the flame is in line with the upturned end of the wire cloth and the other edge of the flame extends into the front end of the specimen. See Fig. X1.2.

X1.7.5 Start the timing device when the flame is first applied to the specimen. After 60 s, remove the burner at least 150 mm away from the test specimen. Record the time in seconds when the flame front reaches the gage mark; if this does not occur, record the time in seconds for the flame to go out. If the flame goes out before reaching the gage mark, the extent of burning is equal to 125 mm minus the distance from the gage mark to the nearest evidence of the flame front, such as charring, along the upper surface of the specimen measured

to the nearest 2 mm. Note burning characteristics, such as intumescence, melting, dripping, or smothering. Also record if the dripping on the foil burns. In some cases, the burning may cease in the first 60 s. This is evident by the disappearance of the yellow or characteristic flame.

### X1.8 Calculation

X1.8.1 If the flame front passes the gage mark in any one of the five specimens, the sample shall be judged as burning. The burning rate is calculated by the following equation:

$$A = B/C \quad (X1.1)$$

where:

- A = burning rate, mm/s,
- B = distance to gage mark 125 mm, and
- C = time for flame to reach gage mark, s.

If only one specimen burns past the gage mark, its burning rate shall be reported, otherwise the average of the specimens that burn past the gage mark shall be reported.

X1.8.2 If the flame front does not reach the gage mark for all five specimens, average the burning time in seconds and average the distance burned in millimetres as measured on the top surface.

### X1.9 Report

X1.9.1 The report shall include the following information:

X1.9.1.1 A description of the material including the density, the width and thickness, and any prior treatment or conditioning and the presence or absence of skin. If the specimen had skins, the report shall include whether the skin surface was up or down.

X1.9.2 Sample that burned to the gage mark, the burning rate in millimetres/second.

X1.9.3 For samples that did not burn to the gage mark, report the average time of burning and the average extent of burning.

*Example:*

ATBXX<sub>a</sub> AEBXX<sub>mes</sub>

where:

ATB = average time of burning, and

AEB = average extent of burning.

X1.9.4 A description of burning characteristics, such as melting, dripping, or intumescence and whether the dripping or melting materials continued to burn on the aluminum foil.

X1.9.5 The caveat contained in X1.1.4 herein shall be incorporated in its entirety in the test report issued.

### X1.10 Precision and Bias

X1.10.1 Interlaboratory round-robin testing<sup>12</sup> has established the precision for each part of the test as follows:

X1.10.2 *Reproducibility*—The standard deviation for interlaboratory reproducibility is:

For burning rates	±0.08 mm/s
For ATB	±8.5 s
For AEB	±9.9 mm

---

<sup>12</sup> Supporting data giving results of cooperative tests have been filed at ASTM Headquarters. Request RR-D20-1036.

*ASTM International takes no position respecting the validity of any patent rights asserted in connection with any item mentioned in this standard. Users of this standard are expressly advised that determination of the validity of any such patent rights, and the risk of infringement of such rights, are entirely their own responsibility.*

*This standard is subject to revision at any time by the responsible technical committee and must be reviewed every five years and if not revised, either reapproved or withdrawn. Your comments are invited either for revision of this standard or for additional standards and should be addressed to ASTM International Headquarters. Your comments will receive careful consideration at a meeting of the responsible technical committee, which you may attend. If you feel that your comments have not received a fair hearing you should make your views known to the ASTM Committee on Standards, at the address shown below.*

*This standard is copyrighted by ASTM International, 100 Barr Harbor Drive, PO Box C700, West Conshohocken, PA 19428-2959, United States. Individual reprints (single or multiple copies) of this standard may be obtained by contacting ASTM at the above address or at 610-832-9585 (phone), 610-832-9555 (fax), or service@astm.org (e-mail); or through the ASTM website (www.astm.org).*