



Designation: D 2112 – 00

Standard Test Method for Oxidation Stability of Inhibited Mineral Insulating Oil by Pressure Vessel¹

This standard is issued under the fixed designation D 2112; the number immediately following the designation indicates the year of original adoption or, in the case of revision, the year of last revision. A number in parentheses indicates the year of last reapproval. A superscript epsilon (ϵ) indicates an editorial change since the last revision or reapproval.

1. Scope

1.1 This test method is intended as a rapid method for the evaluation of the oxidation stability of new mineral insulating oils containing a synthetic oxidation inhibitor. This test is considered of value in checking the oxidation stability of new mineral insulating oils containing 2,6-ditertiary-butyl para-cresol or 2,6-ditertiary-butyl phenol, or both, in order to control the continuity of this property from shipment to shipment. The applicability of this procedure for use with inhibited mineral insulating oils of more than 12 cSt at 40°C (approximately 65 SUS at 100°F) has not been established.

1.2 *This standard does not purport to address all of the safety concerns, if any, associated with its use. It is the responsibility of whoever uses this standard to consult and establish appropriate safety and health practices and determine the applicability of regulatory limitations prior to use.*

NOTE 1—A modification of this test method, which uses the same procedure and apparatus but a higher (150°C) bath temperature, has been published as Test Method D 2272.

2. Referenced Documents

2.1 *ASTM Standards:*

B 1 Specification for Hard-Drawn Copper Wire²

D 2272 Test Method for Oxidation Stability of Steam Turbine Oils by Rotating Bomb³

E 1 Specification for ASTM Thermometers⁴

3. Summary of Test Method

3.1 The test specimen is agitated by rotating axially at 100 rpm at an angle of 30° from the horizontal, under an initial oxygen pressure of 90 psi (620 kPa), in a stainless steel or copper vessel (for rapid temperature equilibrium), with a glass test specimen container and copper catalyst coil, in the pres-



FIG. 1 Rotating Bomb Oxidation Test Apparatus

ence of water, at a bath temperature of 140°C. The time for an oil to react with a given volume of oxygen is measured; completion of the test is indicated by a specific drop in pressure.

4. Significance and Use

4.1 This is a control test of oxidation stability of new, inhibited mineral insulating oils for determining the induction period of oxidation inhibitors under prescribed accelerated aging conditions. There is no proven correlation between oil performance in this test and performance in service. However, the test method may be used to check the continuity of oxidation stability of production oils.

5. Apparatus

5.1 *Oxidation Vessel*— Glass test specimen container with cover and catalyst coil, pressure gage, thermometer, test bath, and accessories as described in Annex A1. The assembled apparatus is shown in Fig. 1, and its design shown schematically in Fig. 2.

6. Reagents and Materials

6.1 *Purity of Reagents*—Use reagent grade chemicals in all tests. Unless otherwise indicated, all reagents shall conform to

¹ This test method is under the jurisdiction of ASTM Committee D-27 on Electrical Insulating Liquids and Gases and is the direct responsibility of Subcommittee D27.06 on Chemical Test.

Current edition approved April 10, 2000. Published June 2000. Originally published as D 2112 – 62 T. Last previous edition D 2112 – 95.

² *Annual Book of ASTM Standards*, Vol 02.03.

³ *Annual Book of ASTM Standards*, Vol 05.01.

⁴ *Annual Book of ASTM Standards*, Vol 14.03.

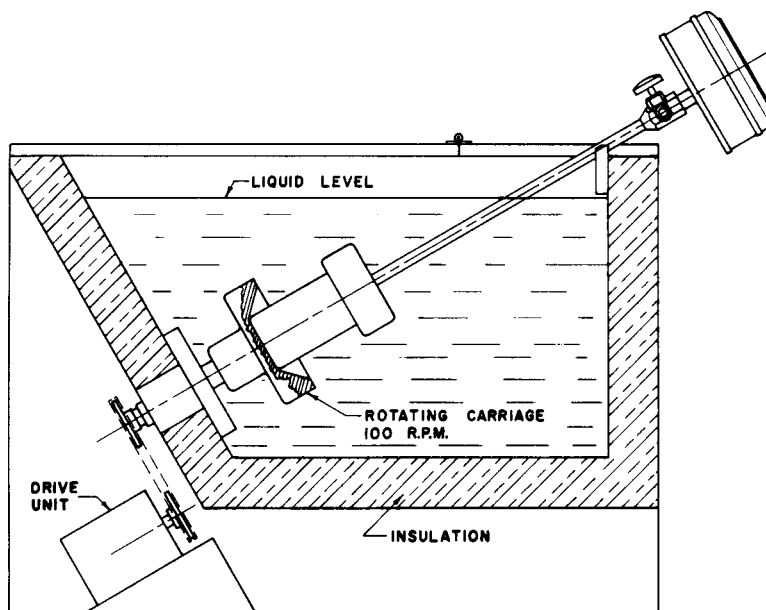

FIG. 2 Schematic Drawing of Rotary Vessel

the specifications of the Committee on Analytical Reagents of the American Chemical Society, where such specifications are available.⁵

6.2 *Hydrochloric Acid, 10 vol %.*

6.3 *Silicon Carbide Abrasive Cloth, 100-grit with cloth backing.*

6.4 *Chloroform, cp. or Acetone, cp.*

6.5 *2-Propanol, 99 vol %, refined.*

6.6 *Liquid Detergent.*

6.7 *Oxygen, 99.5 %, with pressure regulation above 90 psi (620 kPa).* (**Warning**—Oxygen vigorously accelerates combustion).

6.8 *Potassium Hydroxide, Alcohol Solution (1 mass %)*—Dissolve 7.93 g of potassium hydroxide (KOH) pellets in 1 L of 99 % refined 2-propanol.

6.9 *Silicone Stopcock Grease.*

6.10 *Wire Catalyst*—AWG No. 14 (0.0641-in. (1.628-mm) diameter) electrolytic copper wire 99.9 % purity, conforming to Specification B 1. Soft-drawn copper wire of an equivalent grade may also be used.

7. Hazards

7.1 Consult Material Safety Data Sheets for all materials used in this test method.

8. Preparation of Apparatus

8.1 *Catalyst Preparation*—Immediately before use, polish the copper wire with silicon carbide abrasive cloth and wipe free from abrasives with a clean dry cloth. Wind approximately 3 m of the wire into a coil having an outside diameter of 44 to

48 mm and stretched to a height of 40 to 42 mm. Clean the coil thoroughly with chloroform or acetone and allow it to air-dry. Immediately after air drying, insert the coil with a twisting motion into the glass test specimen container. Handle the coil only with clean tongs to avoid contamination. Weigh the coil and the container to the nearest 0.1 g and record the weight. Prepare a new coil for each test specimen.

8.2 *Alternative Method of Catalyst Preparation*—Wind approximately 3 m of copper wire into a coil of the dimensions specified in 8.1, and add to the glass container. Weigh the coil and container to the nearest 0.1 g and record the weight. Wash the coil by filling the container above the level of the coil with 10 % hydrochloric acid by volume for 30 s. Discard the acid and rinse the coils three times with tap water followed by three times with distilled water. Reweigh the coil and container and determine by difference the water retained in the system. The coils are now ready for use. This procedure has been found to be acceptable for treatment of commercially available, pre-packaged, preformed coils that meet the requirement described in this test method. Use a new coil for each test specimen.

8.3 *Cleaning of Vessel*—Wash the vessel body, lid, and inside of vessel stem with hot detergent solution and with water. Rinse inside of stem with 2-propanol and blow dry with clean dry air. An alternative cleaning solution is the use of a 50/50 volumetric blend of methanol and acetone; it has been found to be effective in cleaning sludge from the vessel. If the vessel body, lid, or inside of stem smells sour after simple cleaning, wash with alcoholic KOH solution and repeat as before (see Note 2).

NOTE 2—Insufficient cleaning of the vessel may adversely affect test results.

9. Procedure

9.1 *Charging*—Weigh 50 ± 0.5 g of oil sample into the container, add 5 mL of distilled water, and cover with a 2-in. (51-mm) watch glass or a 2¼-in. (57.2-mm) PTFE disk with

⁵ *Reagent Chemicals, American Chemical Society Specifications*, American Chemical Society, Washington, DC. For suggestions on the testing of reagents not listed by the American Chemical Society, see *Analar Standards for Laboratory Chemicals*, BDH Ltd., Poole, Dorset, U.K., and the *United States Pharmacopeia and National Formulary*, U.S. Pharmacopeial Convention, Inc. (USPC), Rockville, MD.

one or four holes and retaining spring. If rinse water is present in the container, compensate for it by using less added water based on the water retention determined in 8.3. Add 5 mL of distilled water to the vessel and slide the test specimen container and cover lid into the vessel body (see Note 3). Apply a thin coating of silicone stopcock grease to the O-ring bomb seal located in the gasket groove of the vessel lid to provide lubrication, and insert the lid into the vessel body. Place the vessel cap over the vessel stem, and tighten by hand. Cover the threads of the gage-nipple with a thin coating of stopcock grease or TFE-fluorocarbon, or both, and screw the gage into the top-center tap of the vessel stem. Flush the vessel twice with oxygen supplied to the vessel at 90 psi (620 kPa) and release to the atmosphere. Adjust the regulating valve on the oxygen supply tank to 90 psi at a room temperature of 25°C (77°F). For each 2.8°C (5.1°F) above or below this temperature, add or subtract 1 psi (7 kPa) unit to attain the required initial pressure. Fill the vessel to this required pressure and close the inlet valve securely by hand. If desired, test the vessel for leaks by immersion in water (see Note 4). Prepare a duplicate test specimen in exactly the same way.

NOTE 3—The water between the vessel well and the test specimen container aids heat transfer.

NOTE 4—If the vessel was immersed in water to check for leaks, dry the outside of the wet vessel by any convenient means such as an air blast or a towel. Such drying is advisable to prevent subsequent introduction of free water into the hot oil bath, which would cause sputtering.

9.2 *Oxidation*—Bring the heating bath to the test temperature of 140°C while the stirrer is in operation. Insert the vessels into the rotating carriages and note the time. If an auxiliary heater is used, keep it on for the first 5 min of the run and then turn it off (see Note 5). Allow the bath temperature to level out at the test temperature; this must occur within 10 min after the

vessels are inserted. Maintain the test temperature within $\pm 0.1^\circ\text{C}$ (see Note 6).

NOTE 5—The time for the bath to reach the operating temperature after insertion of the vessels may differ for different apparatus assemblies and should be observed for each unit. The objective is to find a set of conditions that does not permit a drop of more than 2°C after insertion of the vessels and allows the vessel pressure to reach a plateau within 15 min as shown in Curve A of Fig. 3.

NOTE 6—Maintaining the *correct* temperature within the specification limits of $\pm 0.1^\circ\text{C}$ during the entire test run is the most important single factor ensuring good repeatability and reproducibility of test results.

9.3 Keep the bombs completely submerged and maintain rotation continuously and uniformly throughout the test. A standard rotational speed of 100 ± 5 rpm is required; any appreciable variations in this speed could cause erratic results. If a dial gage is used, take readings every 5 min.

9.4 The test is complete after the pressure drops more than 25 psi (172 kPa) below the maximum pressure. The 25-psi pressure drop usually, but not always, coincides with an induction-type “period of rapid pressure drop.” When it does not, the operator should question whether a valid experiment has been produced.

NOTE 7—A typical experiment is shown in Fig. 3 as Curve A. The maximum pressure expected to be reached within 30 min; a pressure plateau is established and an induction-type pressure drop is observed. Curve B, in which there is a gradual decrease in pressure before the induction break is recorded, is more difficult to evaluate. The gradual decrease in pressure could be due to a vessel leak; however, some synthetic fluids will generate this type of curve. If a leak is suspected, repeat the test in a different vessel. If the same type of curve is derived when the test is repeated, the experiment is likely valid.

9.5 After termination of the test, remove the vessels from the oil bath, dip briefly into and swirl around in a bath of light mineral oil or detergent and water to wash off the adhering bath

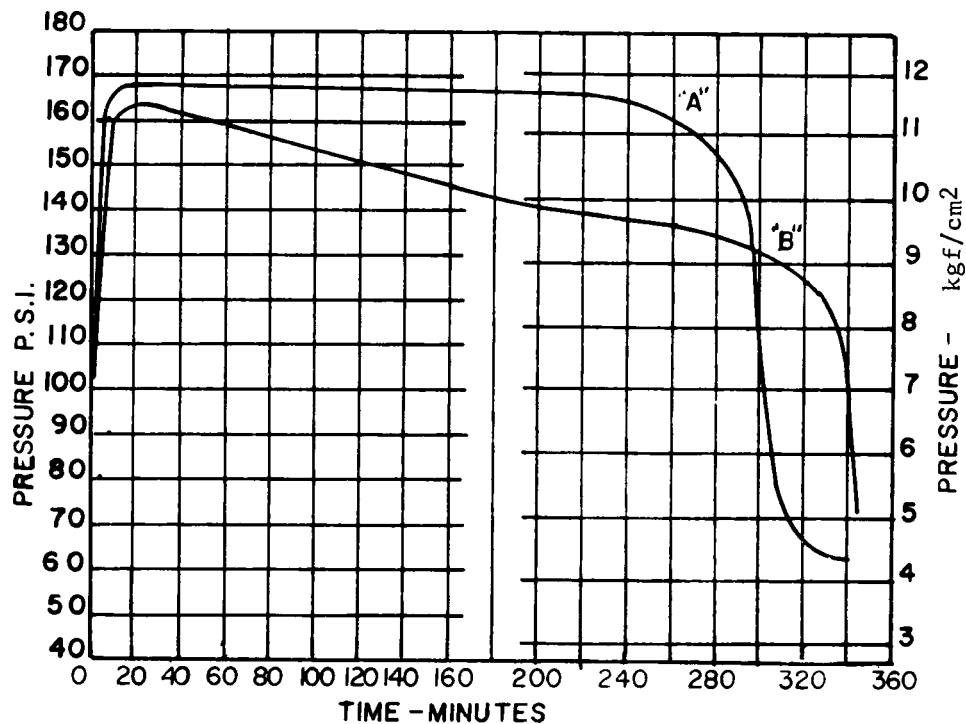

FIG. 3 Pressure Versus Time Plot of Two Rotary Vessel Oxidation Test Runs

oil. Rinse off the vessels with hot water, then immerse in cold water to bring them quickly to room temperature. Allow the vessel to fully cool before bleeding off excess oxygen pressure and opening the vessel.

NOTE 8—A hazardous situation can arise when excess oxygen is bled off immediately upon removal of the vessel from the bath since it may be accompanied by hot oil and steam.

10. Interpretation of Results

10.1 Observe a plot of the recorded pressure versus time and establish the plateau pressure (see Note 7). Also record the time at the point on the falling part of the curve where the pressure is 25 psi (172 kPa) less than the established plateau pressure. Plateau pressures in duplicate tests should not differ by more than 5 psi (35 kPa).

10.2 The vessel life of the test specimen is the time in minutes from the start of the test to a 25-psi pressure drop from the level of the established plateau.

11. Report

11.1 Report the time as the average of two duplicate determinations and the difference of the individual determina-

tions. The recipient of the report can then be reassured that the determination is not suspect, as specified in 12.1.

12. Precision and Bias

12.1 The following criteria should be used for judging the acceptability of results (95 % probability):

12.1.1 *Repeatability*— Duplicate determinations by the same operator should not be considered suspect unless they differ by more than 23 min. If the two results differ by more than the specified value, another set of duplicate tests should be performed.

12.1.2 *Reproducibility*— Results submitted by each of two laboratories based on the average of two determinations in each laboratory should not be considered suspect unless they differ by more than 43 min.

12.2 No justifiable statement can be made on the bias of the procedure in this test method since there is no accepted reference material suitable for determining oxidation stability.

13. Keywords

13.1 electrical; inhibitor; insulating oil; mineral oil; oxidation stability; rotating vessel; transformer oil

ANNEX

(Mandatory Information)

A1. ROTATING VESSEL OXIDATION TEST APPARATUS

A1.1 Oxidation Vessel

A1.1.1 Construct the oxidation vessel,⁶ with lid, cap, and stem, as shown in Fig. A1.1.

A1.1.2 Machine the vessel body and lid from a 3-in. (76-mm) solid copper rod for maximum rate of heat transfer. Give the interior surface a smooth finish to facilitate cleaning. Heavily chrome plate the vessel body and lid. Alternatively, the vessel body and cap may be constructed of 18-8 or 321S12/321S20 Part 1 (BSI) stainless steel to ensure a proper rate of heat transfer.

A1.1.3 Construct the vessel stem of stainless steel, equipped with an inside diameter of ¼ in. (6.35 mm) and equip with a ¼-in. needle valve.

A1.1.4 Make the vessel cap (or closure ring) of plated steel.

A1.1.5 The vessel shall withstand a working pressure of 500 psi (3.4 MPa) at 150°C.

A1.1.6 O-ring gaskets, TFE-fluorocarbon resin reinforced silicone, 2 in. (50.8 mm) in inside diameter by 2¾ in. (60.3 mm) in outside diameter, or alternatively Buna-N gaskets with the same dimensions.

A1.2 Glass Sample Container

A1.2.1 Construct the glass test specimen container, 175-mL

capacity, with copper catalyst coil, of borosilicate glass as shown in Fig. A1.2.

A1.2.2 Cover the top of the test specimen container with a 2-in. (50.8-mm) diameter watch glass. Fire polish the watch glass edges. TFE-fluorocarbon watch glasses are also acceptable.

A1.2.3 The glass test specimen container shall have a sliding fit in the vessel with no excess side clearance. The container alone shall have a maximum wall thickness of 2.5 mm and weigh no more than 100 g.

A1.3 Gage

A1.3.1 The range of the gage,⁷ recording, (see chart in Fig. A1.3) indicating or equivalent, must span a range from at least 0 to 200 psi (1.4 MPa) and graduated or reading in maximum 5-psi (35-kPa) divisions.

A1.3.2 The accuracy of the gage must be 2 % or less of the total scale interval.

A1.3.3 Mount the recording gages so that the face is perpendicular to the axis of rotation.

A1.4 Oxidation Bath

A1.4.1 Equip the oxidation bath⁶ with an efficient stirrer and a suitable device for holding and rotating the vessel axially at

⁶ Bombs, glass test specimen containers, recording pressure gages, and accessories, available from the Koehler Instrument Co., Inc., 1595 Sycamore Ave., Bohemia, NY 11716, have been found satisfactory for this purpose. Baths holding two, three, or four bombs are also available.

⁷ Minicorder gage type 3X range 200 psi (1.4 MPa), manufactured by the Dickson Co., Chicago, IL, and available from the Koehler Instrument Co., Inc., Bohemia, NY, for mounting in the preferred position has been found satisfactory for this purpose.

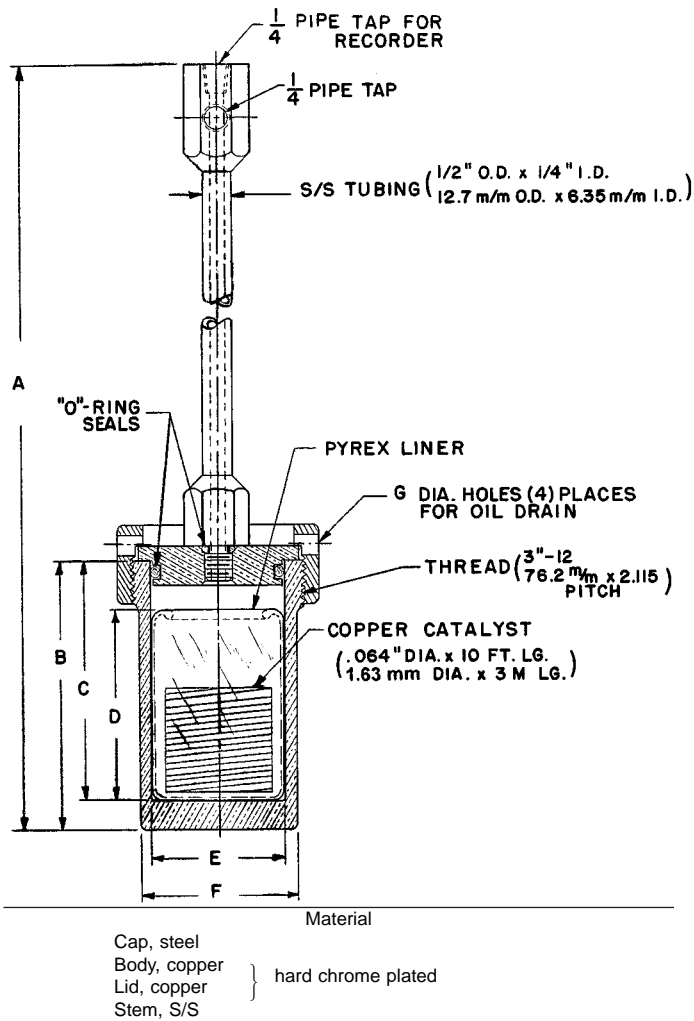

	in.	mm
A	2 1/8	536.8
B	4 3/4	120.65
C	4 1/4	107.95
D	3 3/8 to 3 1/2	86 to 89
E	2.375 + 0.010	60.325/60.579
	-0.000	
F	2 3/4	69.85
G	3/8	9.525

FIG. A1.1 Construction of Oxidation Vessel

an angle of 30° at 100 ± 5 rpm while submerged in oil to a point at least 1 in. (25.4 mm) below the level of the bath liquid.

A1.4.2 A bath at least 9-in. (230-mm) deep, filled with 8 gal (30.3 L) of heavy bath oil per vessel, has the proper heat capacity. Metal block baths are not satisfactory for this service.

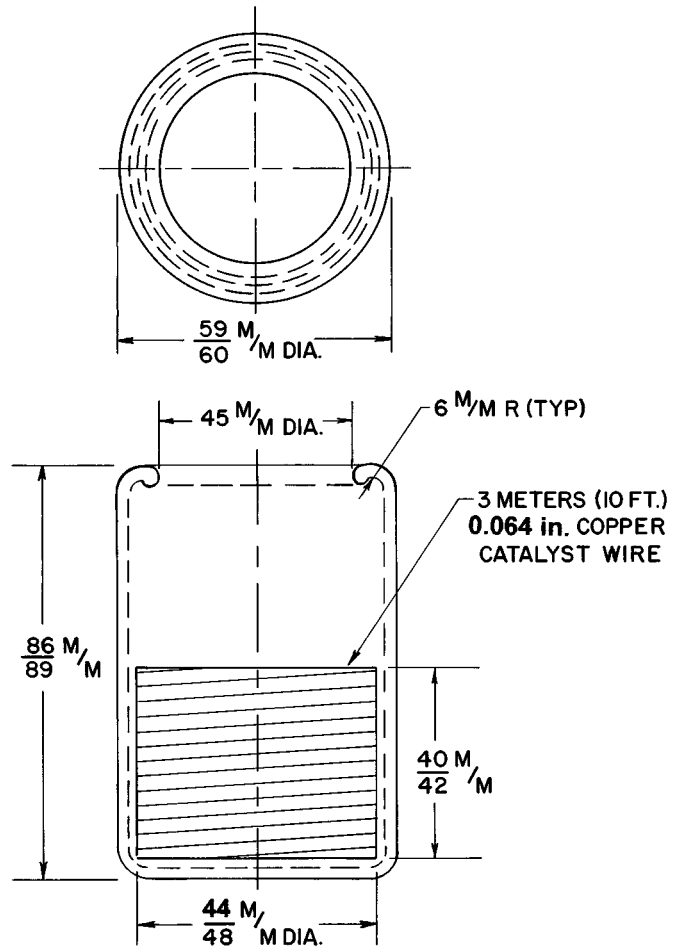

FIG. A1.2 Glass Sample Container with Catalyst

A1.4.3 Provide thermal regulation to maintain the bath within ± 0.1°C of the test temperature (140°C) for periods as long as 8 h and to ensure sufficient heat is available to bring the bombs to operating temperature within 10 to 15 min.

A1.5 Thermometer

A1.5.1 ASTM Solidification Point Thermometer 96C, having a range from 120 to 150°C, graduated in 0.1°C intervals, described in Specification E 1. Place the thermometer in the bath so that it is submerged to the immersion mark.

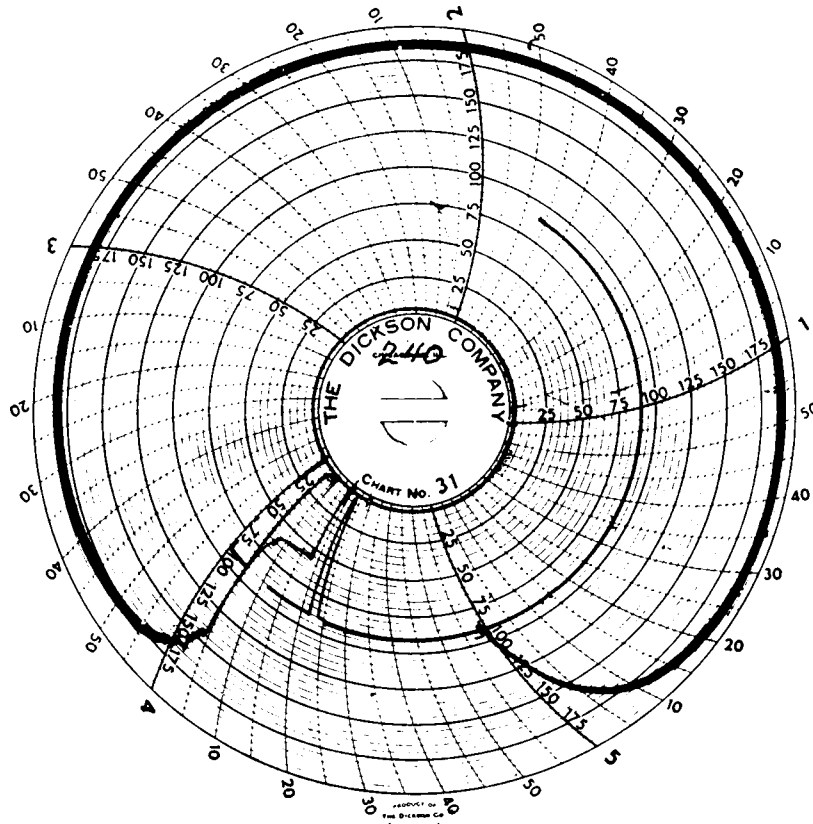

FIG. A1.3 Chart of Recording Pressure Gage (Actual Size = 4½ in. (114 mm))

The American Society for Testing and Materials takes no position respecting the validity of any patent rights asserted in connection with any item mentioned in this standard. Users of this standard are expressly advised that determination of the validity of any such patent rights, and the risk of infringement of such rights, are entirely their own responsibility.

This standard is subject to revision at any time by the responsible technical committee and must be reviewed every five years and if not revised, either reapproved or withdrawn. Your comments are invited either for revision of this standard or for additional standards and should be addressed to ASTM Headquarters. Your comments will receive careful consideration at a meeting of the responsible technical committee, which you may attend. If you feel that your comments have not received a fair hearing you should make your views known to the ASTM Committee on Standards, at the address shown below.

This standard is copyrighted by ASTM, 100 Barr Harbor Drive, PO Box C700, West Conshohocken, PA 19428-2959, United States. Individual reprints (single or multiple copies) of this standard may be obtained by contacting ASTM at the above address or at 610-832-9585 (phone), 610-832-9555 (fax), or service@astm.org (e-mail); or through the ASTM website (www.astm.org).