



Designation: **F 1505 – 9401**

Standard Specification for Insulated and Insulating Hand Tools¹

This standard is issued under the fixed designation F 1505; the number immediately following the designation indicates the year of original adoption or, in the case of revision, the year of last revision. A number in parentheses indicates the year of last reapproval. A superscript epsilon (ϵ) indicates an editorial change since the last revision or reapproval.

1. Scope

1.1 This specification covers the ~~acceptance~~ testing of insulated and insulating hand-held tools used for working on, or in close proximity to, energized electrical apparatus or conductors operating at maximum voltage of 1000- V ac or 1500- V dc.

1.2 The use and maintenance of these tools ~~is~~ are beyond the scope of this specification.

1.3 The values stated in SI units are to be regarded as the standard. The inch-pound units given in parentheses are for information only.

1.4 The following precautionary caveat pertains to the test method portion only, Section 7₂ of this specification: *This standard does not purport to address all of the safety concerns, if any, associated with its use. It is the responsibility of the user of this standard to establish appropriate safety and health practices and determine the applicability of regulatory limitations prior to use.*

1.5 This specification does not purport to address all of the safety problems associated with the use of tools on, or in close proximity to, energized electrical apparatus.

2. Referenced Documents

2.1 ASTM Standards:

D 149 Test Method for Dielectric Breakdown Voltage and Dielectric Strength of Solid Electrical Insulating Materials at Commercial Power Frequencies²

¹ This specification is under the jurisdiction of ASTM Committee F-18 on Electrical Protective Equipment for Workers and is the direct responsibility of Subcommittee F18.35 F18.20 on Tools and Equipment—Tools.

Current edition approved Feb. 15, 1994. Published April 1994. March 10, 2001. Published June 2001. Originally published as F 1505-94. Last previous edition F 1505-94.

D 618 Practice for Conditioning Plastics and Electrical Insulating Materials for Testing³

2.2 *ASME/ANSI Standard:*

ASME/ANSI B107 Series⁴

2.3 *IEC Standards:*

IEC- 60900 (IEC 900:1987 + amend. 1995) Hand Tools for Live Working up to 1000 V a.c. and 1500 V d.c.⁵

3. Terminology

3.1 *Definitions:*

3.1.1 *insulated hand tools, n*—those covered with insulating material in order to protect the user from electric shock and to minimize the risk of short circuits between parts at different potentials.

3.1.2 *insulating hand tools, n*—those made predominantly of insulating material, except for metal inserts at the working head or active part or used for reinforcement but with no exposed metal parts. In either case, to protect the user from electric shocks, as well as, to prevent short-circuits between exposed parts at different potentials.

3.2 *Definitions of Terms Specific to This Standard:*

3.2.1 *acceptance test, n*—a contractual test to prove to the customer that the device meets certain conditions of its specification.

3.2.2 *routine test*—~~a test to which each individual device~~ formation of lots or batches, n—the product is subjected during assembled into identifiable lots, sub-lots, batches, or after manufacture to ascertain whether it complies with certain criteria in such other manner as may be prescribed. Each lot or batch, as far as practicable, consists of units of product of a single type, grade, class, size, and composition, manufactured under essentially the same conditions and essentially the same time.

3.2.3 *sampling routine test, n*—~~a test on a number of devices taken at random from a batch. to which each individual device is subjected during or after manufacture to ascertain whether it complies with certain criteria.~~

3.2.4 *typesampling test, n*—a test on a number of devices taken at random from a batch.

3.2.5 *type test, n*—a test of one or more devices made to a certain design to show that the design meets certain specifications.

4. Significance and Use

4.1 ~~The performance and durability of the tools covered in this specification are not covered beyond those referenced in the applicable ASME/ANSI or ISO standards.~~

4.2 ~~The technical requirements of this specification are in compliance with IEC 900 at the time of issue.~~

5. Performance Requirements

5.1 ~~Insulated and insulating tools shall be designed and manufactured in such a way that they do not constitute a danger for the user or the installation if they are used properly used.~~

5.2 ~~The mechanical specifications for insulated and insulating hand tools having a similar the same function shall comply with the corresponding ANSI or ISO standards. The mechanical performance of the working parts shall be maintained even after the application of any insulating layer(s). The insulation material shall be such that it will adequately withstand the electrical, mechanical, and thermal stresses to which it may be exposed during normal use. Insulating hand tools specially designed for live working in an environment of live parts at different potentials (boxes with electrical equipment, live working on underground cables, etc.), that are generally are used to hold or move live conductors or to cut wires of small section, must have adequate mechanical properties to avoid the risk of breaking and the possible corresponding electrical consequences. These tools shall be checked for compliance with 7.8.~~

5.3 ~~All insulating material shall be flame resistant in accordance with 7.7.~~

5.4 ~~The insulating coating shall may consist of one or more layers. If two or more layers are utilized, contrasting colors shall be employed. (The inner layer may be transparent.)~~

5.5 ~~The handle employed.~~

4.5 ~~The design and construction of the tool handles shall provide a secure handhold and prevent unintentional slipping.~~

5.6 ~~The tool shall have an operating temperature range from — 20 to + 70°C.~~

5.7 ~~The insulating material shall adhere securely to the conductive parts of the tool and any outer layer of the material over the temperature range from — 20 to + 70°C.~~

5.8 ~~Tools intended for use at extremely low temperatures (–40°C) shall be designated “Category C” and shall be designed for this purpose.~~

4.9 ~~Double-ended tools such as box wrenches, keys for hexagonal socket screws, double ended socket wrenches, double-head open-end wrenches, etc., are not allowed for insulated tools but are allowed for insulating tools.~~

5.9.10 ~~Tools capable of being assembled shall have retaining devices to avoid unintentional separation of the assembly.~~

² Annual Book of ASTM Standards, Vol 10.01.

³ Annual Book of ASTM Standards, Vol 08.01.

⁴ Available from American Society of Mechanical Engineers, 345 E. 47th Street, New York, NY 10017.

⁵ Available from the Institute of Electrical and Electronics Engineers, Inc., 345 E. 47th Street, New York, NY 10017.

54.101 In the case of connecting parts of tools capable of being assembled, the insulation shall be applied in such a manner that if any part becomes detached during use, no conductive part, which may still be live, can be inadvertently touched inadvertently or cause a flashover.

6. Other

4.12 Tools capable of being assembled and designed to be interchangeable between different manufacturers shall be specifically categorized and marked as such.

5. Additional Requirements

65.1 *Screwdrivers and Wrenches*—The following uninsulated areas on the working head are permissible:

65.1.1 *Screwdrivers* for slotted head screws, 15-mm ($\frac{9}{16}$ -in.) maximum length,

65.1.2 *Other Types of Screwdrivers*, 18-mm ($\frac{3}{4}$ -in.) maximum length, and

~~6.1.3 Open-end wrenches, box wrenches, socket wrenches,~~

~~5.1.3 Box Wrenches, Socket Wrenches, and Tee Wrenches: the Tee Wrenches~~—The working surfaces that contact the fastener.

65.1.4 *Engineer's Wrenches*—The working surface.

5.2 The blade insulation of screwdrivers shall be bonded to the handle. The outer diameter of the insulation, over a length of 30 mm ($1\frac{3}{4}$ ($1\frac{3}{16}$ in.)), in Area C of Fig. 1, shall not exceed the width of the blade at the tip; by more than 2 mm ($\frac{1}{16}$ in.). This area may be parallel or tapered towards the tip.

65.3 *Pliers, Strippers, Cable Cutting Tools (and Other Hinge-Jointed Tools) Tools, Cable Scissors:*

65.3.1 The handle insulation shall have a guard so that the hand is prevented from slipping towards the uncovered metal parts of the head: (See Fig. 2(a)) as an example). The height of the guard shall be sufficient to resist slippage of the fingers towards the conductive part during work. For pliers, the minimum dimensions of the guard shall be 10 mm ($\frac{3}{8}$ in.) on the left and the right side of the pliers positioned on a flat surface; 5 mm ($\frac{3}{16}$ in.) on the top upper and on the bottom lower part of the pliers positioned on a flat surface (see Fig. 2(a)).

65.3.2 The minimum insulated distance between the inner edge of the guard and the tool non-insulated part shall be 12 mm ($\frac{1}{2}$ in.); (See Fig. 2(a)). The insulating material shall extend as far as possible towards the working end of the tool.

~~NOTE 1—Sufficient length of grip shall be provided so as to permit use of~~

~~5.3.3 In the tool without placing fingers over guards.~~

~~6.3.3 In the case of a slip joint, a guard of 5 mm ($\frac{3}{16}$ in.) minimum shall be provided for the inner part of the handles.~~

65.3.4 In the case of “micro tools,” the hand guard may be reduced.

65.3.5 If the handles of the tools exceed the length of 400 mm (16 in.), a guard is not required.

65.4 *Knives*—The minimum length of the insulated handle shall be 100 mm (4 in.). The handle shall have a guard on the side (see Fig. 2(b)) toward the blade to prevent the slipping of the hand onto the conductive blade. The minimum height of the guard shall be 5 mm ($\frac{3}{16}$ in.). The minimum insulated distance between the inner edge of the guard and the non-insulated part shall be 12 mm ($\frac{1}{2}$ in.) (see Fig. 2(b), letter b). The maximum length of the uninsulated part of the knife blade shall not be longer than 65 mm (2-in.).

6.5 *Product Marking* ($\frac{1}{2}$ -in.) (see Fig. 2b, letter c).

5.5 *Tweezers* (see Fig. 3):

65.5.1 The total length (l) shall be 130-mm (5-in.) minimum and 200-mm (8-in.) maximum. The length of the handle (g) shall be 80-mm (3-in.) minimum.

5.5.2 Both handles of the tweezers shall have a guard towards the working head. The guard shall not be movable. Its height h and width b shall be sufficient (5 mm ($\frac{3}{16}$ in.) minimum, to prevent any slipping of the fingers during the work towards the uninsulated working head u . On both handles, the insulated part between the guard and the working head e shall be 12-mm ($\frac{1}{2}$ -in.) minimum and 35-mm ($1\frac{3}{8}$ -in.) maximum.

5.5.3 In the case of tweezers with a metallic working head, the metallic part shall have a minimum hardness of HCR 35 (Rockwell Hardness – C Scale) at least from the working head to the handles.

5.5.4 The uninsulated length u of the working head shall not exceed a length of 20 mm ($\frac{3}{4}$ in.).

5.5.5 Insulating tweezers shall not have exposed conductive parts.

5.6 *Marking*—Each tool or tool component, or both, shall be marked permanently and legibly ~~marked~~ with the following information:

~~6.5.2 On~~

5.6.1 On the insulating material layer or on the metal conductive part; include the manufacturer's name or trademark.

~~6.5.3 On~~

5.6.2 On the insulating material layer include the following:

6.5.36.2.1 Type or product reference,

6.5.36.2.2 The double triangle symbol (see Fig. 3 4),

6.5.36.2.3 1000-V (the electrical working limit for alternating current), and

6.5.36.2.4 Year of manufacture (at least the last two digits of the year).

5.6.52.5 For tools designed for use at extremely low temperatures (-40°C), include letter “C”.

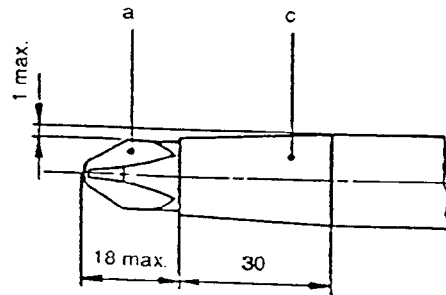
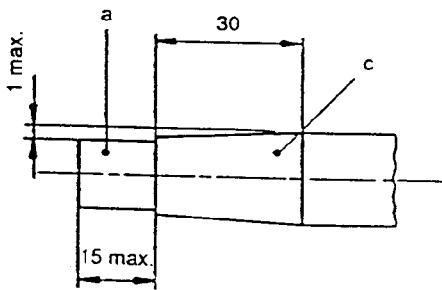
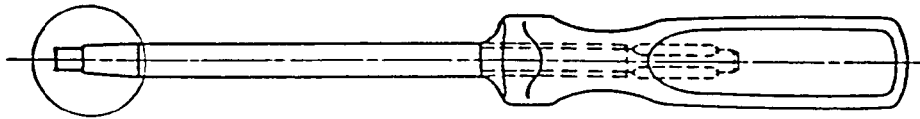
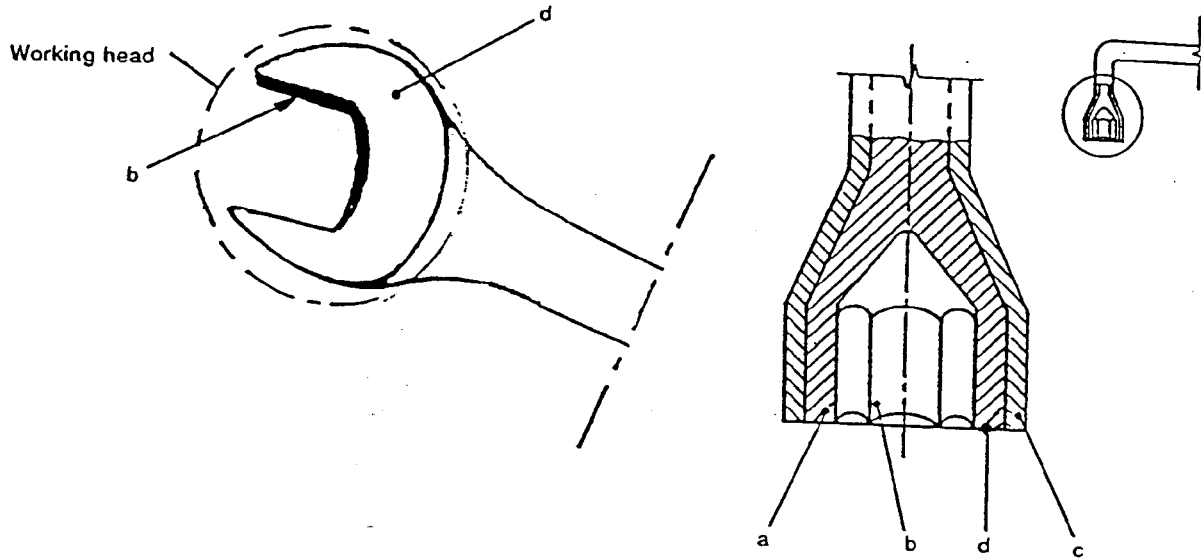

NOTE 1—Dimensions in millimetres.

NOTE 2—a = conductive part,
 b = working part,
 c = insulation, and
 d = contact part.

FIG. 1 Illustrations of Insulation of Typical Tools (Examples)

5.6.3 The double triangle symbol shall be at least 3 mm (1/8 in.) high;†. The letters and the figures shall be at least 2 mm (1/16 in.) high: (See Fig. 3.)

6.5.5 The 4).

5.6.4 The voltage markings shown above in 5.6.2 shall be the only voltage shown on the tool.

NOTE 21—The indication of a test voltage may lead to the erroneous assumption that the tool is suitable for work at that voltage.

5.6.5 Additional markings where specified by the customer.

5.6.6 Additional markings for tools capable of being assembled and designed by to interchangeable between different manufacturers.

5.7 Instructions for Use—In the case of tools that require assembly, the proper method shall be stated in the instructions for use.

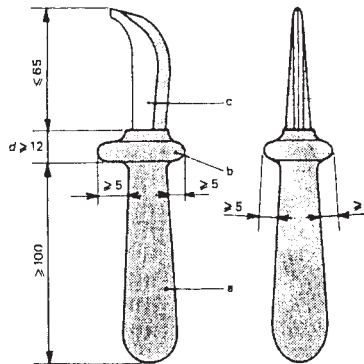
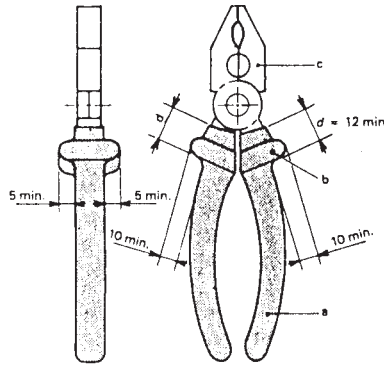

(a) Insulation of Pliers
(b) Insulation of Knives

NOTE 1—Dimensions in millimetres.

NOTE 2—a = insulated handle or leg,

b = guard,

c = working head (not insulated), and

d = distance between the inner edge of the guard and the non-insulated part.

FIG. 2 Illustrations of Insulation of Pliers and Knives

Other instructions, such as verification before use and test methods should be given by the manufacturer, distributor, or user: (See Appendix X4).

6. Significance and Use

6.1 The performance and durability of the tools covered in this specification are not covered beyond those referenced in the applicable ASME, ANSI, or ISO standards.

6.2 The technical requirements of this specification are in compliance with IEC 60900 at the time of issue.

7. Type Tests

7.1 General Test Specification —The following tests shall be utilized to check compliance with the requirements outlined above in Sections 4 and 5:

7.1.1 Carry out the test procedures in 7.2 through 7.10 7.2-7.10 on each specimen sample in the sequence listed.

7.1.2 Carry out the type tests on at least three samples of the same batch.

7.1.3 If there is any change in the design or manufacture of the tool since the last type test, repeat the type test.

7.1.4 Should a sample fail any part of the type tests, repeat the type tests on at least six additional samples of the same batch. Should any one sample then fail in any part of the repeated type test, the whole test is to be regarded as having failed.

7.1.5 Unless stated in the specification, carry out the test after a minimum storage time of 16 h under IEC climatic conditions; $23 \pm 5^\circ\text{C}$, relative humidity 45 to 75 %.

7.1.6 Unless otherwise stated in test clauses, stated, deviations of 5 % from any test values required are permissible.

7.1.7 All tools that have failed the test shall be either destroyed or rendered unsuitable for use in live working. This also applies to any other tools from the batch unless the test is nondestructive. In this case, all tools shall be tested.

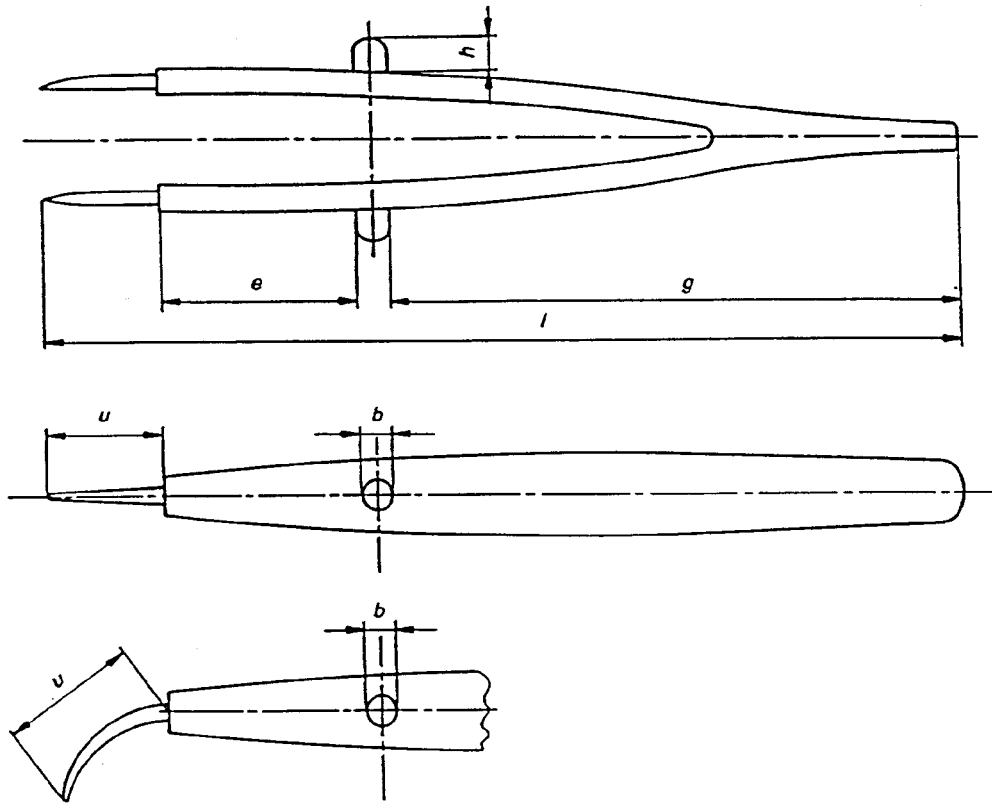

l = total length of the tweezers
g = length of the handle (grip)
b = width of the guard
h = height of the guard
e = insulated part of the handle between the guard and the working head
u = uninsulated part of the working head

FIG. 3 Example for Insulation of the Handles of Tweezers

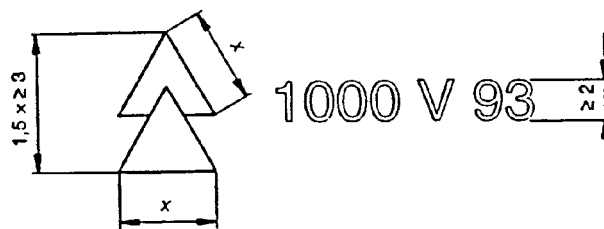

NOTE 1—Ding Symbols in millimetres

FIG. 4 Marking Symbol

7.2 Visual and Dimensional Check :

7.2.1 *Visual*—The tool and insulation shall be visually checked and shall be determined to be free from external defects. The marking shall be checked for legibility and completeness in accordance with 6.5.5.6.

7.2.2 *Dimensional*— Check the dimensions in accordance with Section 6.5.

7.3 Impact Test:

7.3.1 Carry out the test in accordance with one of the two alternatives shown in Fig. 4.5(a)(a) and Fig. 4(b). 4(b). The hardness of the hammer shall be at least 20 HRC.

7.3.2 Select at least three points of the insulating material or insulating layer as testing points, these being points that could be damaged when the tool drops on a flat surface.

7.3.3 The test is passed if the insulating material shows no breaks, exfoliations, or cracks penetrating the insulating layer of the

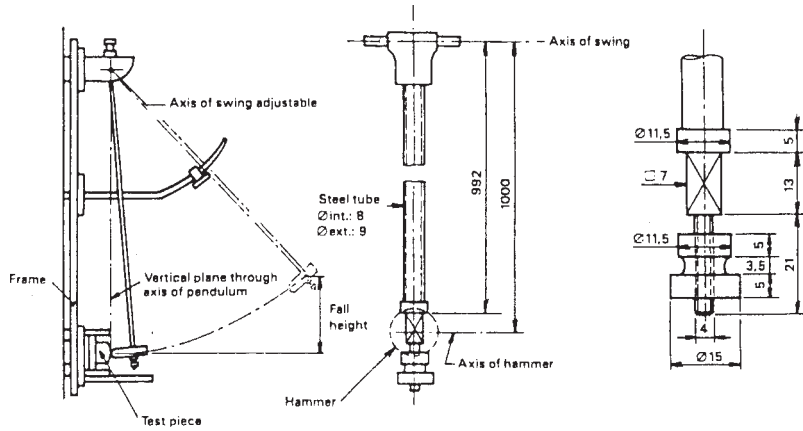

Pendulum for impact test

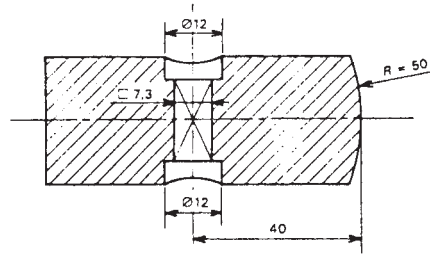

Hammer

(a) Method A

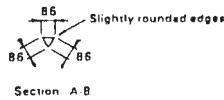
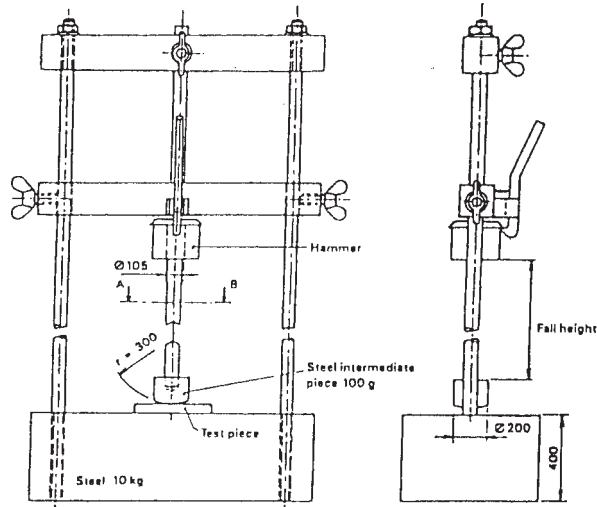

(b) Method B

NOTE 1—Dimensions in millimetres.

FIG. 4 5 Example of Test Arrangements for the Low-Temperature Impact Test

insulated tool, or are likely to reduce the solidity of the insulating tool.

7.3.4 Ambient Temperature Test:

7.3.4.1 Test the tool at the ambient temperature ($23 \pm 5^\circ\text{C}$) of the test room.

7.3.4.2 Determine the fall height H as a function of its weight, P , so that the energy, W , of impact on the tool to be tested shall be equal to that of this tool falling from a height of 2 mm onto a hard surface:

$$H = \frac{W}{P} = \frac{2 \times F}{P}$$

$$H = (W) / (P) = (2 \times F) / (P) \quad (1)$$

where:

H = fall height of the hammer, m,
 F = weight of the tool tested, N, and
 P = weight of the hammer, N.

7.3.5 *Low-Temperature Test*—:

7.3.5.1 Condition the tool by placement in a cooling chamber for 2 h at $25 \pm 3^\circ\text{C}$.

7.3.5.2 The impact test shall take place within 2 min after removal from the cooling chamber. The ambient temperature shall be $23 \pm 5^\circ\text{C}$.

7.3.5.3 Determine the fall height H as a function of its weight, P , so that the energy, W , of the impact on the tool to be tested shall be equal to that of the tool falling from a height of 0.6 m onto a hard surface:

$$H = WP = 0.6 \times FP \quad (2)$$

$$H = (W) / (P) = (0.6 \times F) / (P) \quad (2)$$

where:

H = fall height of the hammer, m,
 F = weight of the tool tested, N, and
 P = weight of the hammer, N.

7.3.6 *Extreme Low Temperature Test*—The tool shall be conditioned by placement in a cooling chamber for 2 h at $-40^\circ\text{C} \pm 3^\circ\text{C}$. The impact test shall be carried out according to 7.3.5.

7.4 *Dielectric Test—Conditioning Before Testing*—Condition the tools by total immersion in a bath of tap water at room temperature ($23 \pm 5^\circ\text{C}$) for a period of 24 ± 0.5 h.

7.4.1 In the case of tools capable of being field assembled, the water immersion shall be replaced by a storage at a relative humidity between 91 % and 95 % at a temperature of $23 \pm 5^\circ\text{C}$ for 48 h. Tools shall not be assembled prior to conditioning.

NOTE 2—This humidity may be obtained by storage in a closed chamber which contains a saturated solution of sodium sulfate decahydrate $\text{Na}_2\text{SO}_4 \cdot 10\text{H}_2\text{O}$ (Glauber's salt) having a large exposed surface.

7.4.2 After this conditioning, wipe the tools dry and submit to the following dielectric tests:

7.4.2.1 *Insulated Tools*—Immerse the sample tool with its insulated part in a bath of tap water to a level of 24 ± 2 mm ($1 \pm \frac{1}{16}$ in.) from the nearest non-insulated part. The conductive part shall be above water level (see Fig. 5 6) with its insulated part in a bath of tap water to a level of 24 ± 2 mm ($1 \pm \frac{1}{16}$ in.) from the nearest non-insulated part. The conductive part shall be above water level.

7.4.1.1 *Test*.

7.4.3.1 Test pliers and similar tools in such a position that the gap “D” “d” between the two inner sides of the insulated handles is 2 to 3 mm ($\frac{1}{16}$ to $\frac{1}{8}$ in.), or the minimum possible by the tools construction, but not less than 2 mm ($\frac{1}{16}$ in.) (see Fig. 6).

7.4.3.2 For tools capable of being field assembled, replace the water bath by a bath of 3- mm ($\frac{1}{8}$ - in.) diameter nickel stainless steel or copper/steel balls (measured measured with normal industrial tolerances).

7.4.3.3 Continuously apply a voltage of 10 kV (rms) at commercial power frequencies for 3 min in accordance with IEC 60; and measure the leakage current. This current shall be less than 1 mA for 200 mm ($2\frac{5}{32}$ (8 in.) of coated tool. This corresponds to a maximum value of the leakage current of:

$$I = 5L$$

of: $I = 5L$

where:

I = Leakage current rounded to the upper value, mA, and
 L = Coated developed length in m (rounded to the lower value; in centimeters).

NOTE 3—Appendix X1 gives examples of calculations of the developed length of coating and the limits of acceptable leakage current.

7.4.3.4 Test tools capable of being field assembled in all possible variations. Test tools with holding devices on both end positions, if applicable. The test is considered passed if no electrical puncture, sparkover, or flashover occurs during the test period, and the limits of the leakage current are not exceeded.

7.4.24 *Insulating Tools—Dielectric Test Between the Working Head and the Handle (or Handles):*

7.4.2.1 *Tools Having Only One Working Head With or Without*

7.4.4.1 Tools having a Conductive Part—Cover the metallic working head with conductive tape, foil, or conductive paint shall

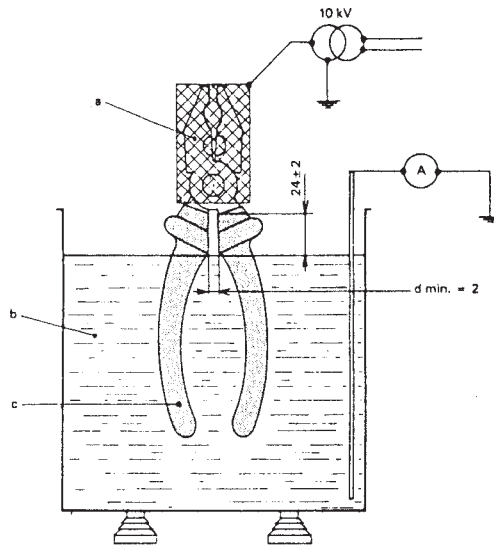

NOTE 1—Dimensions in millimetres.

NOTE 2—a = conductive working head,

b = tap water bath,

c = insulated part of the tool, and

d = gap to be maintained between the two inner sides of the legs.

FIG. 5.6 Electrical Testing Device for Insulated Tools

be tested in contact accordance with all exposed conductive parts 7.4.3.

7.4.4.2 *Tools Having No Exposed Metal Parts*—The purpose of the working head. Also cover the body of the tool (one or two handles) with conductive tape, foil, or conductive paint, and in the places usually touched by the user's hand (guard included). The distance between the conductive tape placed on the working head, or any metallic part related this test is to it, and check the conductive tape placed on the body dielectric quality of the tool nearest to material used for the working head shall be 22 ± 2 mm. (See handles. Electrodes (see Fig. 6 7.)

7.4.2.2 A voltage of 10 kV rms at commercial power frequencies shall be continuously applied for 3 min in accordance with Test Method D 149 between the working head and the handle of the tool. Measure the leakage current. The test is successful if no electrical puncture or flashover occurs during the test period, and if the leakage current measured is less than 0.5 mA.

7.4.2.3 *Tools Having Two or More Working Heads*—Repeat the same test as in 7.4.2.2 in all configurations.

7.4.3 *Dielectric Test of the Handles*—The purpose of this test is to check the dielectric quality of the material used for the handles. Electrodes (see Fig. 6) of conductive tape, foil, or conductive paint 5-mm ($\frac{3}{16}$ -in.) wide are placed on the surface of the handles at 40 mm ($1\frac{19}{32}$ 24 \pm 2-mm ($1\frac{5}{16} \pm \frac{1}{16}$ in.) spacing. Continuously apply a spacing.

7.4.4.3 A voltage of 10 kV rms at commercial power frequencies shall be continuously applied for 3 min in accordance with Test Methods D 149 between two consecutive electrodes. each adjacent electrode. Measure the leakage current. The test is considered passed successful if no electrical puncture or flashover occurs during the test period, and if the leakage current measured is less than 0.5 mA multiplied by the number of spaces between the electrodes.

7.5 Indentation Tests (for Insulated Tools):

7.5.1 All parts of the insulated coating electrically tested in accordance with 7.4 shall pass this test. Perform the test on the most vulnerable part(s) for screwdrivers with insulated blades, and for other tools, at the external middle part of the handles.

7.5.2 If the radius, r , at the test point is greater than or equal to 10 mm ($\frac{3}{8}$ in.), make the test with a test device in accordance with Fig. 7 8a in a heating chamber with natural ventilation. The part of the mass, Mm , that contacts the test piece shall be a stainless steel hemispheric nose piece of 5-mm ($\frac{3}{16}$ -in.) diameter. The applied force F shall be 20 N (4.5 lbf).

7.5.3 If the radius, r , at the test point is less than 10 mm ($\frac{3}{8}$ in.), use a rod of 5 mm 4-mm ($\frac{3}{16}$ -in.) diameter at least 30-mm ($1\frac{3}{4}$ to $1\frac{3}{16}$ -in.) length with the same force, F , of 20 N (4.5 lbf) placed at right angles to the tool axis (see Fig. 8b).

7.5.4 Position the tool in such a way that the insulating material coating at the test point is in a horizontal position. After setting up the testing device, hold the arrangement in accordance with Methods Practice D 618 ($2h[\text{sol}]70^\circ\text{C}[\text{sol}] < 20\%$). At the end of the heating time and after a cooling period outside the chamber of 5 min, apply a voltage of ± 10 5 kV rms at commercial power frequencies continuously between the testing device and the conductive part of the tool for 3 min in accordance with Test Method D 149. The test is successful if no electrical puncture, sparkover, or flashover occurs during the test period.

7.6 Test for Adhesion of the Insulating Material Coating for Insulated Tools:

7.6.1 *Conditioning*— Condition the tools before the test in a heating chamber with normal ventilation at a temperature of $70 \pm 2^\circ\text{C}$ for 168 h in accordance with Test Method D 149. Carry out the following tests at room temperature between the third and

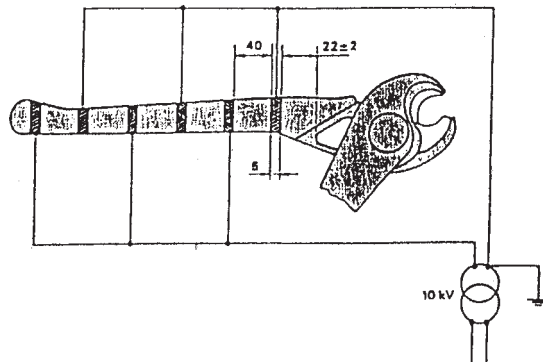
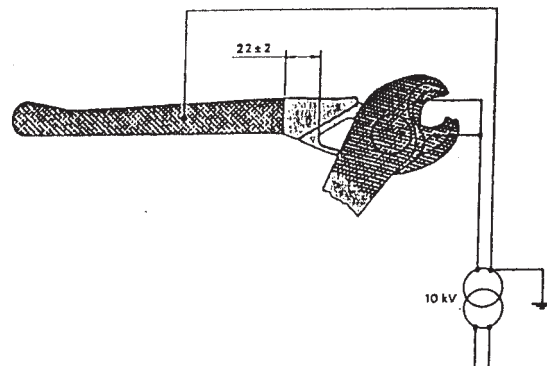
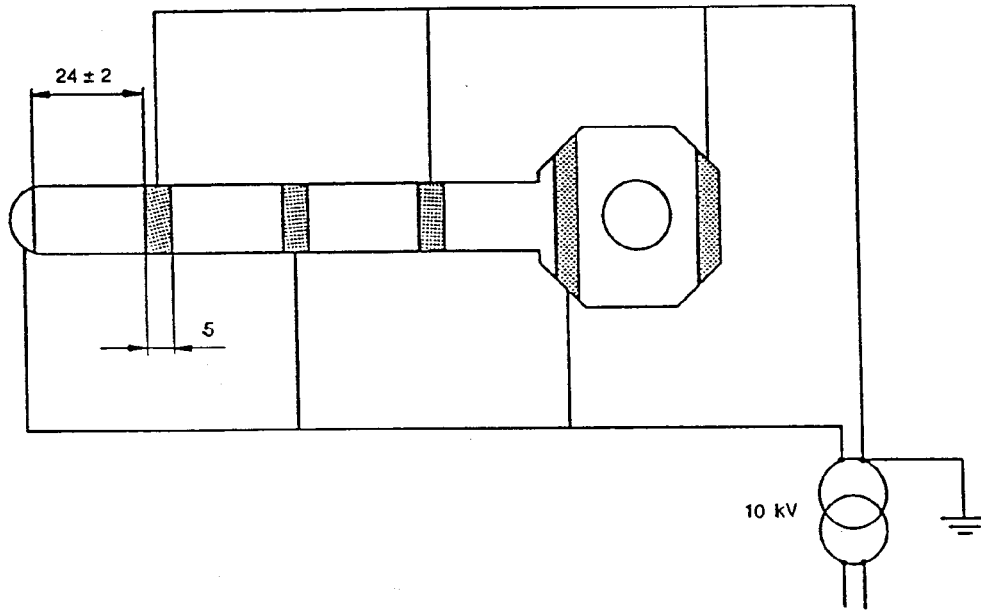

(a) Dielectric Test Between the Working Head and the Handle or the Legs
 (b) Dielectric Test of the Handle or Legs

FIG. 6 Dielee

NOTICE TESTING 1—Device Insulating Tool millimetres
FIG. 7 Dielectric Testing Device for Insulating Tools

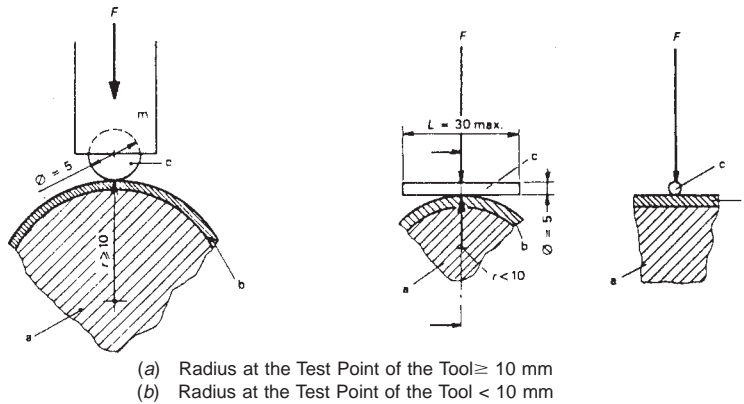

NOTE 1—Dimensions in millimetres.

NOTE 2—For Fig. 7(a):

- a = conductive part,
- b = insulation (test point),
- c = hemispheric nose-piece,
- r = radius at the test point of the tool, and
- m = testing mass.

NOTE 3—For Fig. 7(b):

- a = conductive part,
- b = insulation (test point),
- c = rod, and
- d = radius at the test point of the tool.

FIG. 7 8 Indentation Test

fifth minute after removal from the heating chamber in accordance with Method Practice D 618.

7.6.2 *Test on the Working Head*—Make the test on the following tools: wrenches (that is, open-end, box-end, and adjustable wrenches); any other tool with a covered working head; and tools capable of being assembled (except for pieces acting as screwdrivers). The test may be carried out using either method in Fig. 8 9a and Fig. 9 9b respectively.

7.6.2.1 *Test Method A* (See Fig. 8 9a)—Place a hook having a cutting edge of 5-mm ($3/16$ -in.) width in such a manner that it does not touch the conductive part. Apply a force, F , of 50 N (11.25 lbf) in the direction of the line dividing the insulating material coating from the conductive part for 3 min.

7.6.2.2 *Test Method B* (See Fig. 10 Fig. 9b)—Place a device having the cutting edges, each of 5-mm ($3/16$ -in.) width, on the working head in such a manner that they do not touch the conductive part. Apply a force, F , of 100 N (22.4 lbf) in the direction of the dividing line of the insulating material coating and the conductive part for 3 min.

7.6.2.3 Either test is considered passed if the insulating material coating does not move more than 3 mm ($1/8$ in.) from its initial location on the conductive part, and if there is no breakage of the insulating material.

7.6.3 *Test on the Insulation of the Blade of Screwdrivers:*

7.6.3.1 Carry out the test on a screwdriver with the testing apparatus as shown in Fig. 11 10. The penetration depth of the cutting edges of the testing apparatus shall not exceed 50 % of the insulating thickness, t , of the insulating material coating. Place the cutting edges on the blade insulation 10 to 15 mm ($3/8$ to $5/8$ in.) from the point where the blade emerges from the handle.

7.6.3.2 If the cutting edges slide on the insulation, it is permissible to cut a groove up to 50 % of the thickness into the blade insulation to prevent movement.

7.6.3.3 The force, F , in Newtons shall be equal to 35 times the blade diameter or 35 times the greatest dimension of the blade cross section in millimetres and applied in the axial direction to the blade for 1 min.

7.6.3.4 The test is considered passed if the insulating coating does not move more than 3 mm ($1/8$ in.) from its initial location on the conductive part and if there is no breakage of the insulating material.

7.6.4 *Test of Adhesion of the Insulation of the Complete Tool:*

7.6.4.1 Conduct the test on pliers, strippers, cable-cutting tools, cable scissors, and knives with the testing apparatus in accordance with Fig. 9 11. Apply the force, F , of 500 N (112.4 lbf) for 3 min.

7.6.4.2 The test is considered passed if the handle(s) remain firmly attached to the conductive part(s), and if the guard(s) remain firmly attached to the handle.

NOTE 34—Deformation of the insulation coating is not considered a failure.

7.7 *Flame Resistance Test*—Carry out the test in a draft-free room. Clamp the sample in a horizontal position. Arrange a small burner in such a way that the axis of the burner nozzle and the axis of the handle of the tool are at right angles; and form a vertical plane. The gas supply shall be technical grade methane gas with a suitable regulator and meter to produce a uniform gas flow.

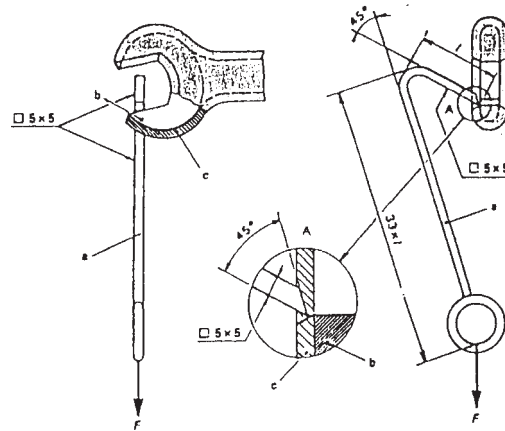

(a) Method A — Test on the Working Head

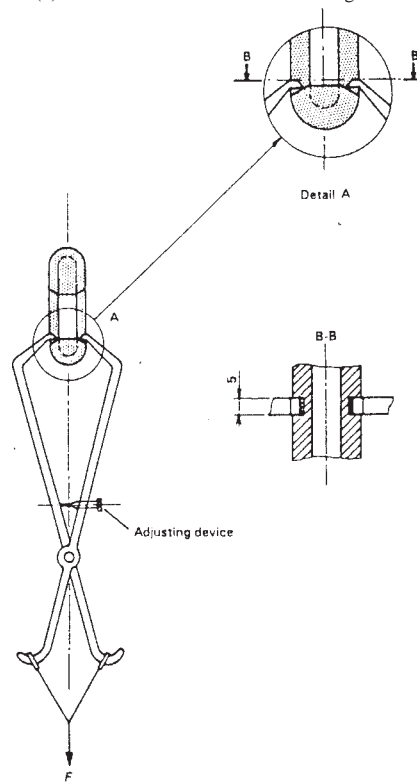

(b) Method B — Test on the Working Head

NOTE 1—Dimensions in millimetres.

NOTE 2—*a* = hook (the length of the leg depends on the size of the tool),

b = conductive parts,

c = insulating material coating, and

l = length of the short arm of the hook.

FIG. 8.9 Principle of the Testing Device for Checking Adhesion of the Insulating Coating on Metallic Parts of the Tools

NOTE 45—If natural gas is used as an alternative to methane, its heat content should be approximately 37 MJ/m^3 that has been found to provide similar results.

7.7.1 The nozzle of the burner shall have a diameter of $9.5 \pm 0.5 \text{ mm}$ ($\frac{3}{8} \pm \frac{1}{32} \text{ in.}$) to produce a $20 \pm 2\text{-mm}$ ($\frac{3}{4} \pm \frac{1}{16}\text{-in.}$) high blue flame. Place the burner remote from the sample and adjust in the vertical position to produce a blue flame $20 \pm 2 \text{ mm}$ ($\frac{3}{4} \pm \frac{1}{16} \text{ in.}$) high. The flame is then is obtained by adjusting the gas supply and the air ports of the burner until a $20 \pm 2\text{-mm}$ ($\frac{3}{4} \pm \frac{1}{16}\text{-in.}$) yellow-tipped blue flame is produced, then increase the air supply until the yellow tip disappears. Measure the height of the flame again, and correct if necessary.

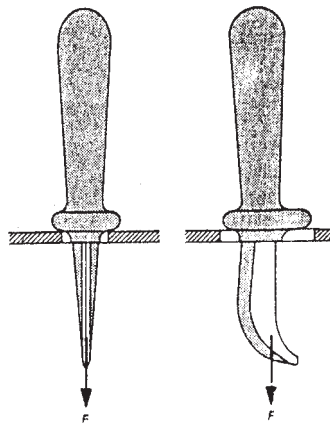
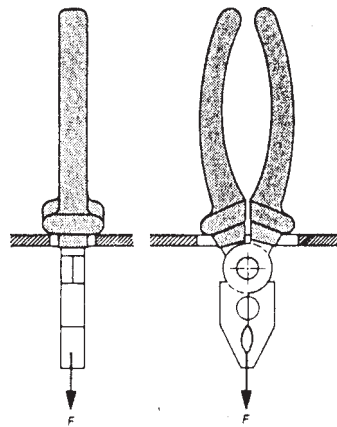
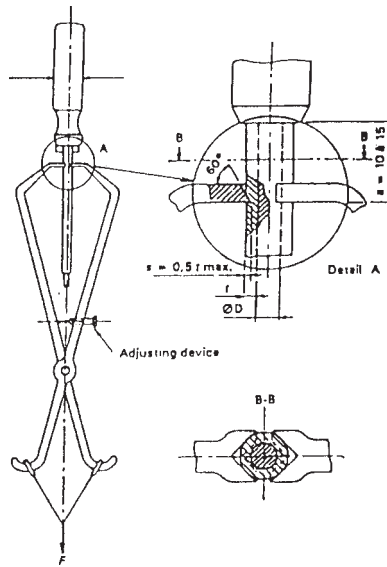

(a) Pliers
(b) Knife

FIG. 9-Exa

NOTE 1—Dimensions in millimetres.

NOTE 2— s = depth of penetration ($s = 0.5 t \text{ max.}$),

t = thickness of the insulating material coating,

F = testing force, and

a = spacing between the point where the blade comes out of the handle and the cutting edge of the testing appliance.

FIG. 10 Testing Device for Checking Adhesion of the Insulating Coating of Screwdrivers on Conductive Parts and the Handle

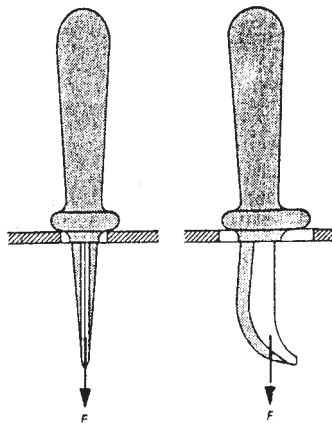
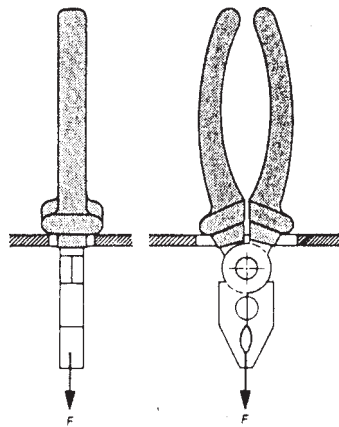
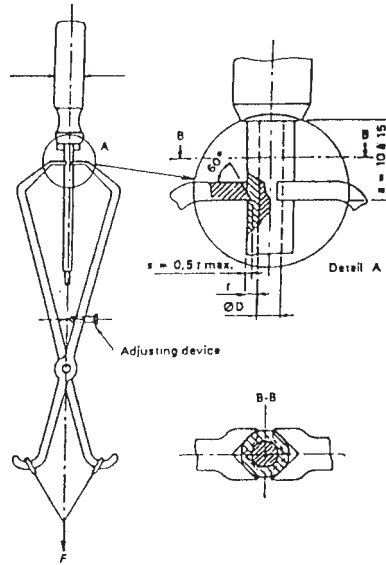

- (a) Pliers
- (b) Knife

Note—

FIG. 1—Dimensions in millimetres:

NOTE 2— s = depth of penetration ($s = 0.5t$ max);
 t = thickness of the Checkinsulating-ma Steriabil-coating;
 F = testing force, and A = spacing between the point where the blade comes out of the handle and the cutting edge of the testing appliance. Tool

7.7.2 Then place

7.7.2 Place the burner in the test position as shown in Fig. 12 with the axis of the flame being at right angles to that of the tool. At the start of the test, the tip of the testing flame should touch the insulating material at the lower part of the working head facing the sample (see Fig. 12). The horizontal reference line No. 4 of Fig. 12 at the level of the lower end of the insulating material, is the datum for measuring the flame height on the sample. If different types of insulating material are used for the same tool, conduct the test made on each individual type insulating material.

7.7.3 The testing flame shall act upon the specimen for 10 s. After this period, withdraw the testing flame. Ensure that no air draft interferes with the test. Observe the propagation of the flame on the sample for 20 s after the withdrawal of the testing flame. The test is considered passed if the flame height, h , on the sample does not exceed 120 mm ($4\frac{3}{4}$ in.) during the 20 s of the observation period and there are no drops of melted material.

7.8 Mechanical Tests:

7.8.1 Insulated Tools— The tools shall comply with all specific mechanical requirements of ANSI/ASME or ISO standards corresponding to the different types of tools. The manufacturers shall provide the certificates of these tests at the request of the customer.

7.8.2 Insulating Tools— Tools with shape and function identical to those of insulated tools, such as wrenches, cutting edges of nippers, etc., shall also shall comply with the corresponding mechanical requirements of applicable ANSI/ASME or ISO standards, or both.

7.8.3 applicable.

7.8.2.1 Pliers and Nippers—Test these tools as follows:

7.8.3.1 Bending

(a) Bending Test of the Handles (See Fig. 11) (see Fig. 13—A force, F , in Newtons shall be applied to the legs as indicated

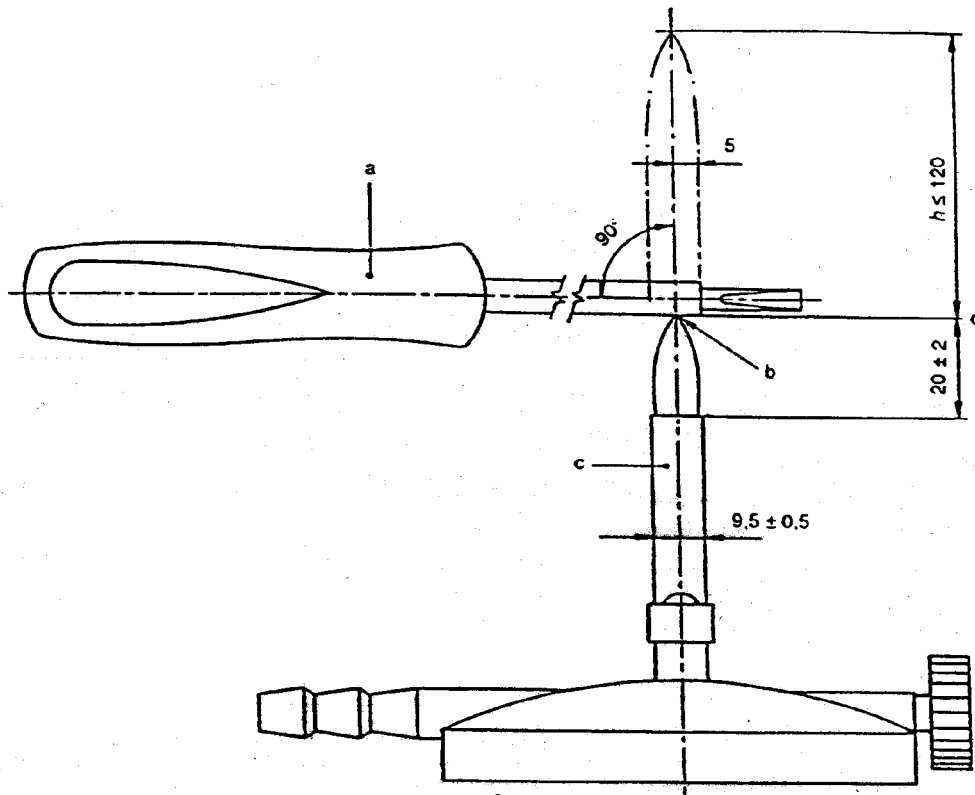

NOTE 1—Dimensions in millimetres.

NOTE 2— a = test piece,

b = tip of the flame,

c = burner,

d = horizontal reference line, and

e = maximum flame height h .

FIG. 12 Example of a Flame Retardancy Test Arrangement

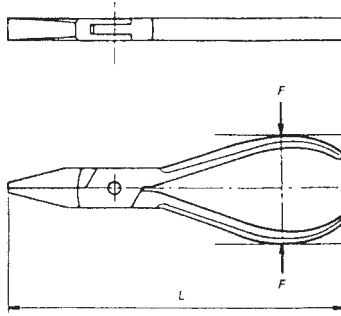

NOTE 1— F (newtons) = $0.5 L$ (mm), with a maximum of 50 N.

FIG. 113 Insulating Pliers;—Bending Test on Legs

in Fig. 113 for 3 min. If L in millimetres is smaller than 100 mm (4 in.), $F = 0.5 L$; if L is equal to or greater than 100 mm (4 in.), $F = 50$ N.

7.8.3.2 The = 50 N. The test is considered passed if there is no break in any part of the tool and if the ends of the legs do not meet.

7.8.3.3 Torque Test (See

(b) Fig. 13(b)) Torque Test (see Fig. 14(b))—Connect the pliers by means of a test piece to a device capable of measuring the torque.

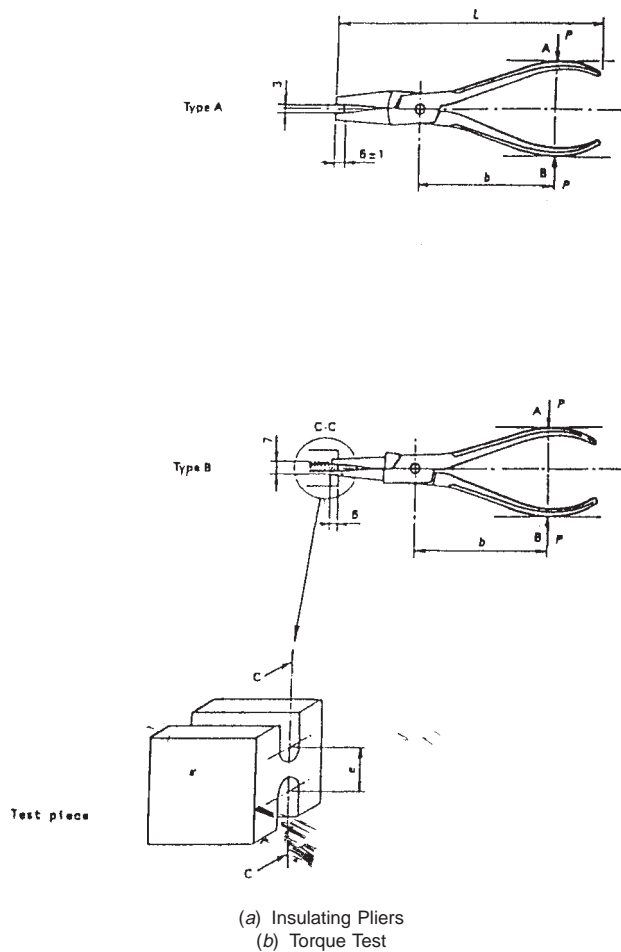

(a) Insulating Pliers
(b) Torque Test

NOTE 1—Dimensions in millimetres.

NOTE 2— e = the distance between the axis of the holes depends on the dimensions of the nose.

NOTE 3— $P = F$ (newtons) = $0.5 L$ (mm) with a maximum of 50 N.

FIG. 134 Insulating Pliers;—Torque Test

7.8.3.4 In

(c) In the case of flat nose pliers, the test piece shall be of steel, 12₋mm (1/2₋in.) wide and 3₋mm (1/8₋in.) thick. Insert into the jaws for a distance of 6 ± 1 mm (1/4 ± 1/32 in.).

7.8.3.5 In

(d) In the case of round-nose pliers, the test piece shall have two parallel holes or grooves with center-axis and diameter adapted to allow the plier noses to be inserted to a depth of 6 ± 1 mm (1/4 ± 1/32 in.). The edges of the holes or grooves shall be rounded. The test pieces shall have a hardness of at least 50 HRC. Tighten the legs of the pliers between the Points A and B, defined by the Length b, with force *P* equal to the force *F* indicated for the bending test. The force in *F* (Newtons) = 0.5 *L* (millimeters) with a maximum of 50 N (11.2 lbf).

~~7.8.3.6 Hold lbf.~~

(e) Hold correctly the handles of the pliers in order to be able to resist the torque.

~~7.8.3.7 The~~

(f) The test is considered passed if the tools withstand a torque of 5 N·m (3.7 ft·lb) without any visible permanent deformation.

7.8.2.2 Tweezers—The required test is the same as 7.8.3. The clamping force shall be not less than 10 N (2.2 lbf) and shall not cause any permanent deformation.

7.9 Locking Test— Assemble tools that consist of more than one part in accordance with the manufacturer’s instructions.

7.9.1 Tools With Spring-Loaded Balls —For ~~detachable~~ tools capable of being assembled with spring-loaded balls, use the following values:

7.9.1.1 4 N (0.89 lbf) for the square drive of 6.3 mm (1/4 in.),

7.9.1.2 11 N (2.7 lbf) for the square drive of 10 mm (3/8 in.),

7.9.1.3 30 N (6.74 lbf) for the square drive of 12.5 mm (1/2 in.), and

7.9.1.4 80 N (17.98 lbf) for the square drive exceeding 12.5 mm (1/2 in.).

7.9.2 Tools With Screwed Fittings —In the case of screwed fittings, use a load of 500 N (112 lbf).

7.9.3 Procedure:

7.9.3.1 Maintain the tool in such a position that the dismantling direction of the detachable part is vertical and downwards.

7.9.3.2 Gradually apply the load along the dismantling direction to reach the value given in 7.9.1 and 7.9.2 within 2 s. Hold for 1 min. The test is considered passed if the assembly does not come apart.

7.10 Durability of Marking—~~If there is any doubt about~~ Rub the durability of the marking, ~~rub~~ the tools for 15 s with a rag soaked in water and then for 15 s with a rag soaked in suitable solvent (mineral spirits). After this rubbing, the markings shall still be legible. ~~NOTE 5—For special service requirements, the customer may specify the durability test.~~

8. Routine Tests

~~8.1 Visual Check~~—~~Visually check the tool (in particular the insulation)~~

~~8.1 Routine tests are performed to be free from external defects. Check the markings for legibility and completeness. Tools failing the visual inspection shall be either repaired or rejected. detect critical defects.~~

8.2 Visual Check— Visually check the tool according to 7.2.1. Tools failing the visual inspection shall be either repaired or rejected.

8.3 Dielectric Test— Test tools in accordance with 7.4, but with the following modifications:

~~8.23.1~~ Conditioning as specified in 7.4.4~~3~~ is not necessary.

~~8.23.2~~ The test time shall be 10 s after reaching the specified voltage.

~~8.23.3~~ The leakage current measurement shall not be carried out.

~~8.23.4~~ The distance of the water level (or ball level) from the nearest exposed metal part shall be 24~~±~~ mm + 4 or – 2 mm (1 ± in. + 1/8 or – 1/16 in.).

~~8.34~~ Test tools ~~with detachable parts capable of being assembled~~ either as a complete assembly or as separate parts.

~~8.34.1~~ The test method used shall be equivalent to the requirements for surface contact in accordance with ~~7.1~~.

~~8.4 Reject tools~~ 7.4.3.

8.5 Tools failing dielectric tests in accordance with 7.4. shall be rejected. Rejected tools shall be either destroyed or rendered unsuitable for use.

9. Sampling Tests

~~9.1 Dimensional Check~~—Carry out a dimensional check

9.1 The sampling procedure shall be based on the type test procedures in accordance conformance with 7.2 using the following:

Batch or Lot Size	Sample Size	Acceptance Number	Rejection Number
2 to 15	2	0	4
16 to 25	3	0	4
26 to 90	5	0	4
91 to 150	8	0	4
151 to 500	13	4	2

~~501 to 1200~~
~~1201 to 10 000~~

~~20~~
~~22~~

~~4~~
~~2~~

~~2~~
~~3~~

~~9.2 Destructive Tests:~~

- ~~9.2.1 Low-temperature impact test, see Section 7;~~
- ~~9.2.2 Dielectric test, see Section 7;~~
- ~~9.2.3 Indentation test, see Section 7;~~
- ~~9.2.4 Adhesion test, see Section 7;~~
- ~~9.2.5 Flame retardancy test, see Section 7, and~~
- ~~9.2.6 Mechanical tests, see Section 7-Appendix X3.~~

10. Acceptance Test

- ~~10.1 The customer shall specify these tests in the contract with the manufacturer (see Appendix X2).~~
- ~~10.2 The manufacturer shall keep records of all tools tests in accordance with Section 7.~~
- ~~10.1.1 If the manufacturer's quality control procedures, for inspection by a prospective customer-i.~~
- ~~10.3 Records also shall be kept of any additional tests requested in by the specification that customer.~~

11. Quality Assurance Plan

~~11.1 In order to ensure the tools must delivery of products that meet this ASTM specification, the acceptance tests are those (both routine and sampling) manufacturer shall employ an approved quality assurance plan that complies with the provisions of ISO 9000 series.~~

~~11.2 The quality assurance plan shall ascertain that the product meets the requirement contained in this specification.~~

~~10.1.2 The customer may wish to witness~~

~~11.3 In the tests, have someone witness the tests, or simply accept the results absence of the test an accepted quality assurance plan as carried out by specified herein, the manufacturer. The customer may also specify that the sampling tests contained in this specification shall be carried out in an independent laboratory of his choosing or in his own laboratory.~~

~~10.1.3 Further, the customer may specify the additional tests or larger sampling sizes when purchasing from a new manufacturer, because the customer has experienced problems with a particular manufacturer, or because of purchasing a new product or a new design.~~

~~(see Appendix X3).~~

APPENDIXES

(Nonmandatory Information)

X1. EXAMPLES OF CALCULATION OF THE DEVELOPED LENGTH OF COATING AND ACCEPTABLE LEAKAGE CURRENT

X2. ACCEPTANCE TESTS

Designations	Developed length of coating L	Limits of acceptable leakage current $I_M = 5 L$
 <p>Engineers' wrench, single head</p>	$L = a$ <i>Example:</i> for a 22 mm wrench $L = a = 0,20$ m	$5 L = 1$ $I_M = 1$ mA
 <p>All-purpose pliers</p>	$L = a_1 + a_2 = 2a_1$ <i>Example:</i> $a_1 = a_2 = 0,14$ m $L = 0,28$ m	$5 L = 1,4$ rounded to $I_M = 2$ mA
 <p>Socket wrench, single head</p>	$L = a_1 + a_2$ <i>Example:</i> $a_1 = 0,10$ m $a_2 = 0,30$ m $L = 0,40$ m	$5 L = 2$ $I_M = 2$ mA
 <p>Speed brace</p>	$L = a_1 + a_2 + a_3 + 2a_4$ <i>Example:</i> $a_1 = 0,30$ m $a_2 = 0,15$ m $a_3 = 0,15$ m $a_4 = 0,25$ m $L = 1,10$ m	$5 L = 5,50$ rounded to $I_M = 6$ mA

FIG. X1.1

X2.1 An acceptance test is a contractual test to prove to the customer that the device meets certain conditions of its specification. These tests may be carried out on every unit (routine tests) or on a sampling of the units (sampling tests).

X2.2 If a customer indicates in this specification that the device must meet this specification only, the acceptance tests are those (both routine and sampling), which are specified in this specification.

X2.3 The customer however, may ask for additional tests or modify the sampling size. These modifications must be included in their specification.

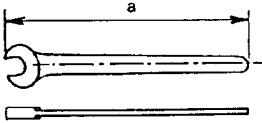
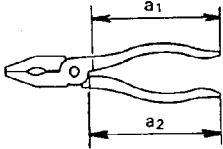
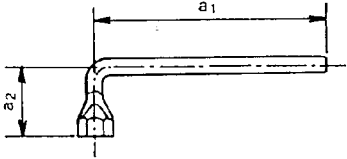
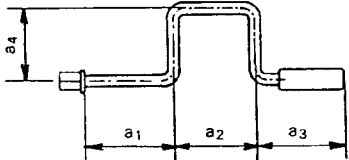
X2.4 The customer may wish to witness the tests, have someone witness them, or simply accept the results of the tests as carried out by the manufacturer. It may be specified that the tests be carried out in an independent laboratory of the customer's choosing or even in his own laboratory.

X3. SAMPLING PROCEDURE

X3.1 General

X3.1.1 The sampling procedure does not follow in its entirety the sampling procedure developed in IEC 410. The product covered by this specification does not lend itself to the application of IEC 410, due to its nature.

X3.1.2 The quality assurance plan used in conjunction with this standard on hand tools should be specially developed, based on the quality assurance practices of ISO 9000 series. If such a quality assurance system does not exist, the procedures in this appendix are applicable.

X3.2 Classification of Defects

X3.2.1 Defects are classified as major or minor. Table X3.1 gives the nature of defects in relation with the tests specified for the sampling procedure.

X3.3 General Sampling Plan

X3.3.1 *Plans for Major Defects*—For major defects, Table X3.2 is limited to 35 000 units. For lots equal to or larger than 35 001, use other test lots less than 35 000 according to Table X3.2.

X3.3.2 *Plans for Minor Defects*—For minor defects, Table X3.2 is limited to 35 000 units. For lots equal to or larger than 35 001, use other test lots less than 35 000 according to Table X3.3.

TABLE X3.3 Minor Defects

Batch or Lot Size	Sample Size	Acceptance Number	Rejection Number
Up to 50	2	0	1
51–500	3	0	1
501–35000	5	1	2

TABLE X3.1 Classification of Defects

Description of Test	Section	Minor Defect	Major Defect
Dimensional	7.2	X	
Impact	7.3		X
Dielectric	7.4		X
Indentation	7.5	X	
Adhesion	7.6		X
Flame retardancy	7.7	X	
Mechanical	7.8	X	
Locking	7.9	X	
Durability of marking	7.10	X	

TABLE X3.2 Major Defects

Batch or Lot Size	Sample Size	Acceptance Number	Rejection Number
Up to 15	2	0	1
16–50	3	0	1
51–150	5	0	1
151–500	8	0	1
501–3200	13	1	2
3201–35000	20	1	2

X4. RECOMMENDATION FOR USE AND IN-SERVICE CARE

X4.1 This appendix is for guidance only for the maintenance, inspection, retest, and use of hand tools after purchase.

X4.1.21 Storage—Hand tools should be ~~properly~~ stored properly to minimize risk of damage to the insulation. Care should be taken that they are not stored in proximity to sources of heat such as steam pipes.

X4.1.32 Inspection Before Use:

X4.1.3.1 Before Use—~~Before~~ use, each hand tool should be ~~visually~~ inspected visually by the ~~user~~.

X4.1.3.2 If user. If there is any doubt concerning the safety of the tool it should either be scrapped or subject to examination by ~~a~~ a competent person and retested if necessary.

X4.1.43 Temperature— According to their compatibility, tools should be used only in areas having ambient temperature between ~~—~~ –20 and +70°C and, for tools marked “C”, between –40 and +70°C.

X4.1.54 Periodic Examination and Electrical Retesting—~~An~~—An annual visual examination by a suitably trained person is recommended to determine the suitability of the tool for further service. If an electrical retest is required by national regulation or by customer specifications or in case of doubt after visual examination, the routine test shall apply.—

ASTM International takes no position respecting the validity of any patent rights asserted in connection with any item mentioned in this standard. Users of this standard are expressly advised that determination of the validity of any such patent rights, and the risk of infringement of such rights, are entirely their own responsibility.

This standard is subject to revision at any time by the responsible technical committee and must be reviewed every five years and if not revised, either reapproved or withdrawn. Your comments are invited either for revision of this standard or for additional standards and should be addressed to ASTM International Headquarters. Your comments will receive careful consideration at a meeting of the responsible technical committee, which you may attend. If you feel that your comments have not received a fair hearing you should make your views known to the ASTM Committee on Standards, at the address shown below.

This standard is copyrighted by ASTM International, 100 Barr Harbor Drive, PO Box C700, West Conshohocken, PA 19428-2959, United States. Individual reprints (single or multiple copies) of this standard may be obtained by contacting ASTM at the above address or at 610-832-9585 (phone), 610-832-9555 (fax), or service@astm.org (e-mail); or through the ASTM website (www.astm.org). acx;