



Standard Test Method for Acoustic Emission Testing of Insulated Digger Derricks¹

This standard is issued under the fixed designation F 1797; the number immediately following the designation indicates the year of original adoption or, in the case of revision, the year of last revision. A number in parentheses indicates the year of last reapproval. A superscript epsilon (ϵ) indicates an editorial change since the last revision or reapproval.

1. Scope

1.1 This test method covers a procedure for acoustic emission (AE) testing of insulated digger derricks.

1.1.1 *Equipment Covered*—This test method applies to special multipurpose vehicle-mounted machines, commonly known as digger derricks. These machines are primarily designed to dig holes, set poles, and position materials and apparatus.

1.1.1.1 Insulated type digger derricks may be evaluated with this test method.

1.1.1.2 Digger derricks, if so equipped to position personnel or equipment, or both, may also be evaluated with this test method in conjunction with Test Method F 914.

1.1.2 *Equipment Not Covered*—Excluded from this test method are general-purpose cranes designed only for lifting service and machines primarily designed only for digging holes.

1.2 The AE test method is used to detect and area-locate emission sources. Verification of emission sources may require the use of other nondestructive test (NDT) methods, such as radiography, ultrasonic, magnetic particle, liquid penetrant, and visual inspection.

1.3 **Precaution**—This test method requires that external loads be applied to the superstructure of the vehicle under test. During the test, caution must be taken to safeguard personnel and equipment against unexpected failure or instability of the vehicle or components.

1.4 *This standard does not purport to address all of the safety concerns, if any, associated with its use. It is the responsibility of the user of this standard to establish appropriate safety and health practices and determine the applicability of regulatory limitations prior to use.*

2. Referenced Documents

2.1 ASTM Standards:

E 569 Practice for Acoustic Emission Monitoring of Structures During Controlled Stimulation²

E 610 Definitions of Terms Relating to Acoustic Emission²

E 650 Guide for Mounting Piezoelectric Acoustic Emission Contact Sensors²

E 750 Practice for Characterizing Acoustic Emission Instrumentation²

E 976 Guide for Determining the Reproducibility of Acoustic Emission Sensor Response²

E 1067 Practice for Acoustic Emission Examination of Fiberglass Reinforced Plastic Resin (FRP) Tanks/Vessels²

F 914 Test Method for Acoustic Emission for Insulated Aerial Personnel Devices³

2.2 Other Standards:

ASNT Recommended Practice SNT-TC-1A—Personnel Qualification and Certification in Nondestructive Testing⁴

ANSI A10.31 Digger Derricks—Safety Requirements, Definitions, and Specifications⁵

EMI Nomenclature and Specifications for Truck-Mounted Extensible Aerial Devices, Articulating Aerial Devices, Digger-Derricks⁶

3. Terminology

3.1 Definitions:

3.1.1 *acoustic emission, AE*—the class of phenomena whereby elastic waves are generated by the rapid release of energy from a localized source or sources within a material, or the transient elastic wave(s) so generated.

3.1.1.1 *Discussion*—acoustic emission is the recommended term for general use. Other terms that have been used in AE literature include (1) stress wave emission, (2) microseismic activity, and (3) emission or acoustic emission with other qualifying modifiers.

3.1.2 *amplitude (acoustic emission signal amplitude)*—the peak voltage of the largest excursion attained by the signal waveform from an emission event.

3.1.3 *amplitude distribution*—a display of the number of acoustic emission events with signals that exceed an arbitrary amplitude as a function of amplitude.

3.1.4 *attenuation*—loss of energy per unit distance, typically measured as loss of signal peak amplitude with unit distance from the source of emission.

¹ This test method is under the jurisdiction of ASTM Committee F-18 on Electrical Protective Equipment for Workers and is the direct responsibility of Subcommittee F18.55 on Acoustic Emission.

Current edition approved Nov. 10, 1998. Published February 1999. Originally published as F 1797–97. Last previous edition F 1797–97.

² *Annual Book of ASTM Standards*, Vol 03.03.

³ *Annual Book of ASTM Standards*, Vol 10.03.

⁴ Available from American Society of Nondestructive Testing, 4153 Arlingate Plaza, Caller #28518, Columbus, OH 43228.

⁵ Available from the American National Standards Institute, 1430 Broadway, New York, NY 10018.

⁶ Available from the Equipment Manufacturer's Institute, 410 N. Michigan Ave., Chicago, IL 60611.

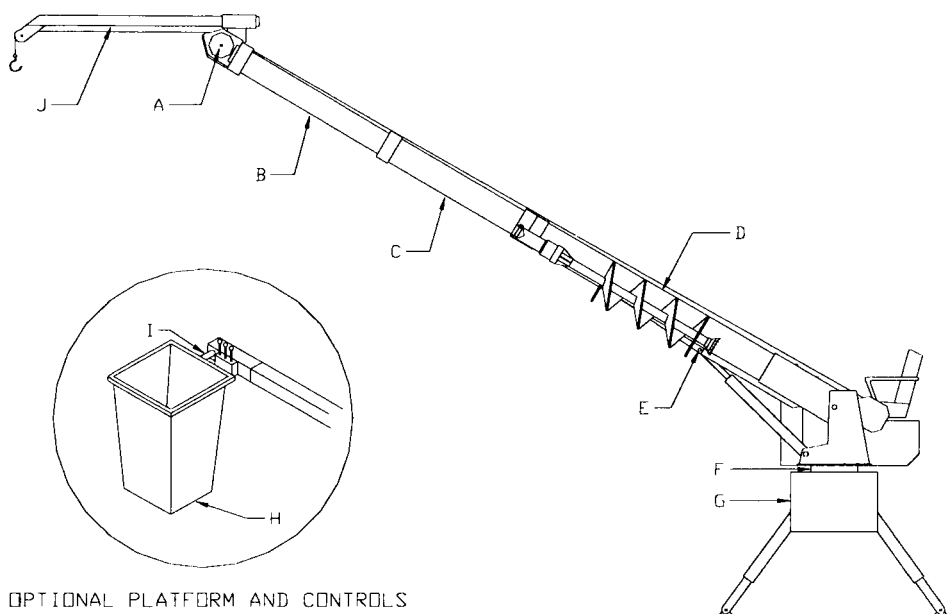

FIG. 1 Insulated Digger Derrick Nomenclature

3.1.5 *channel*—an input to the main AE instrument that accepts a preamplifier output.

3.1.6 *commoned*—two or more sensors interconnected such that the sensor outputs are electronically processed by a single channel without differentiation of sensor origin. (syn. teed)

3.1.7 *count, n*—(acoustic emission count) the number of times the acoustic emission signal amplitude exceeds a preset threshold during any selected portion of a test.

3.1.8 *decibel, dB*—a reference scale that expresses the logarithmic ratio of a signal peak amplitude to a fixed reference amplitude.

$$\text{Signal peak amplitude (dB)} = 20 \log_{10} \frac{A_1}{A_0} \quad (1)$$

where:

A_0 = 1 μV at the sensor output (before amplification), and
 A_1 = peak voltage of the measured acoustic emission signal.

Acoustic Emission Reference Scale

dB Value	Voltage At Sensor Output	Voltage at Integral Preamp Sensor Output (40 dB Gain)
0	1 μV	100 μV
20	10 μV	1 mV
40	100 μV	10 mV
60	1 mV	100 mV
80	10 mV	1 V
100	100 mV	10 V

3.1.9 *event (acoustic emission event)*—a local material change giving rise to acoustic emission.

3.1.10 *event count, N*—the number obtained by counting each discerned acoustic emission event once.

3.1.11 *first-hit*—a mode of operation of AE monitoring equipment in which an event occurring on one channel will prevent all other channels from processing data for a specified period of time. The channel with a sensor closest to the physical location of the emission source will then be the only channel processing data from that source.

3.1.12 *insulator*—any part of the digger derrick such as, but not limited to, any of the extensible boom sections or supporting structure, made of a material having a high dielectric strength, usually FRP or the equivalent.

3.1.13 *noise*—any undesired signal that tends to interfere with the normal reception or processing of the desired signal.

3.1.14 *qualified personnel*—personnel who, by possession of a recognized degree, certificate, professional standing, or skill, and who, by knowledge, training, and experience, have demonstrated the ability to deal with problems relating to the subject matter, the work, or the project.

3.1.15 *signal (emission signal)*—a signal obtained by detection of one or more acoustic emission events.

3.1.16 For definitions of other terms in this test method, refer to Definitions E 610 and the EMI Nomenclature and Specifications.

3.2 Definitions of Terms Specific to the Standard:

3.2.1 *auger*—the hole-boring tool of the digger.

3.2.2 *authorized person*—a qualified person approved and assigned by the user to perform a specific type of duty or duties or to be at a specific location or locations at the job site.

3.2.3 *boom angle indicator*—a device that indicates the angle between the boom and a horizontal plane.

3.2.4 *boom pin*—the horizontal shaft about which the boom pivots as it is raised or lowered relative to the turntable.

3.2.5 *boom tip sheave*—the sheave, located at the tip of a boom, that carries the winch line.

3.2.6 *capacity chart*—a chart that indicates the load capacity or rated capacity of the digger derrick, and by the choice of the user reflects either the load capacity or the rated capacity.

3.2.7 *centerline of rotation*—the vertical axis about which the digger derrick rotates.

3.2.8 *critical members*—those components, members, or structures in a digger derrick whose failure would cause catastrophic failure of the digger derrick system.

3.2.9 *design stress*—the maximum stress at which the component is designed to operate under conditions of rated capacity.

3.2.10 *digger*—the mechanism that drives the auger.

3.2.11 *extension cylinder*—the hydraulic cylinder or cylinders that extend the boom.

3.2.12 *instability*—a condition of a mobile unit in which the sum of the moments tending to overturn the unit is equal to or exceeds the sum of the moments tending to resist overturning.

3.2.13 *intermediate boom (C)*⁷—structural member or members that extend and are located between the upper and lower booms.

3.2.14 *jib*—an auxiliary boom that attaches to the upper boom tip to extend the reach of the boom.

3.2.15 *lift cylinder*—a hydraulic cylinder that lifts the boom.

3.2.16 *load block*—a component consisting of a sheave or sheaves and a hook that is used for multiple parting of the load line.

3.2.17 *load capacity*—the maximum load, specified by the manufacturer, that can be lifted by the mobile unit at regular intervals of load radius and boom angle, through the specified ranges of boom elevation, extension, and rotation, with options installed and inclusive of stability requirements.

3.2.18 *load line*—the load hoisting line.

3.2.19 *lower boom (D)*—the structural member, attached to the turntable, that supports the extensible boom or booms.

3.2.20 *manufacturer*—one who originally constructs the digger derrick.

3.2.21 *model*—manufacturer's designation for digger derrick specified.

3.2.22 *operator*—the person actually engaged in the operation of the digger derrick.

3.2.23 *outrigger cylinder*—the hydraulic cylinder that extends the outrigger.

3.2.24 *outriggers (L)*—the structural members that are extended or deployed to assist in stabilizing the mobile unit.

3.2.25 *pedestal (G)*—the stationary base of the digger derrick that supports the turntable.

3.2.26 *platform (H)*—the optional personnel-carrying component of a digger derrick, such as a bucket, basket, stand, or equivalent.

3.2.27 *platform pin*—the horizontal pin about which the optional platform rotates relative to the boom.

3.2.28 *structural components*—those elements of a digger derrick that are subjected to stress during operation.

3.2.29 *turntable (F)*—the structure above the rotation bearing that supports the booms.

3.2.30 *ultimate strength*—for materials that do not have a clearly defined yield strength, the stress level at which failure of a material will occur.

3.2.31 *upper boom (B)*—the structural member that extends the farthest, and that supports the boom tip sheave, or the optional platform, or both.

3.2.32 *upper boom tip (A)*—the end of the boom farthest from the turntable.

4. Summary of Test Method

4.1 This test method consists of applying a predetermined load to an insulated digger derrick while it is being monitored by sensors that are sensitive to acoustic emissions (AE) caused by active defects. These acoustic emissions can be generated by, but are not limited to, the following: crack nucleation, movement, or propagation in the metal components; or matrix crazing, delamination or fiber breakage of the fiber reinforced plastic (FRP) material, or both.

4.2 The insulated digger derrick is loaded at a uniform rate until a predetermined load is reached, which is held for a period of time. The load is removed and the cycle is repeated. Acoustic emissions are monitored for the components being evaluated during both cycles, and the data is reviewed.

5. Significance and Use

5.1 This test method permits testing of the major components of an insulated digger derrick shown in Table 1. The test method provides a means of detecting acoustic emissions generated by the rapid release of energy from localized sources within the digger derrick under controlled loading. The energy releases occur during intentional application of a predetermined load. These energy releases can be monitored and interpreted by qualified individuals. Acceptance/rejection criteria are beyond the scope of this test method. The test may be discontinued at any time to investigate a particular area of concern, or to avoid imminent damage to the digger derrick resulting from the application of the test load.

5.2 Significant sources of acoustic emission found with this test method shall be evaluated by either more refined acoustic emission test techniques or by other nondestructive methods (visual, liquid penetrant, radiography, ultrasonic, magnetic particle, etc.). Other nondestructive methods may be required in order to precisely locate defects in the digger derrick, and to estimate their size. Additional tests are outside the scope of this test method.

5.3 Defective areas found in digger derricks by this test method should be repaired and retested as appropriate. Repair procedure recommendations are outside the scope of this test method.

6. Personnel Qualifications

6.1 The test method shall be performed by qualified personnel. Qualification shall be in accordance with an established

TABLE 1 Insulated Digger Derrick Components That May be Monitored with Acoustic Emission

Component	Corresponding Letter in Fig. 1
Upper Boom Tip	A ^A
Upper Boom	B ^A
Intermediate Boom(s), if equipped	C
Lower Boom	D
Lower Boom Lift Cylinder Attach Bracket	E
Turntable	F
Pedestal	G
Optional Components—if equipped	
Platform	H
Platform Attachment	I
Jib	J ^A
Jib Bracket/Cylinder Attach Bracket	K ^A
Outriggers	L

^A These components must be monitored.

⁷ Letters in parentheses refer to the corresponding letters in Table 1 and Fig. 1.

written program prepared by a person familiar with design, manufacture, and operation of insulated digger derricks. The program shall include an established format of ASNT SNT-TC-1A for training, qualification, and certification of personnel for conducting AE testing.

NOTE 1—Personnel performing subsequent nondestructive evaluation (visual, liquid penetrant, radiography, ultrasonic, magnetic particle, etc.) on digger derricks should be certified in accordance with ASNT SNT-TC-1A guidelines.

6.2 Acoustic emission test personnel shall be familiar with the design, manufacture, and operation of insulated digger derricks. Relevant information is contained in ANSI A10.31 and manufacturers' operating and service manuals.

7. Acoustic Emission Instrumentation

7.1 The AE instrument shall be capable of data acquisition from discrete channels using 60 kHz and 150 kHz sensors. The number of AE instrument channels shall be determined by the attenuation characteristics of the digger derrick in order to provide coverage of those components identified in Table 1. Refer to the description of mandatory instrumentation characteristics in Annex A1.

NOTE 2—Annex A1 requires the use of a minimum of eight channels.

NOTE 3—The sensors used by most testing agencies are resonant at 60 kHz for FRP components and 150 kHz for metal components. Selection of sensors other than these may significantly affect test results.

8. Test Preparation

8.1 Prior to the AE test, a visual evaluation of the digger derrick shall be performed to determine, as far as practical, that the derrick is free from any condition that may prohibit the test or adversely affect the test results.

8.2 The components to be monitored in an insulated digger derrick shall include, but not be limited to, those specified in Table 1. Additional channels and sensors may be used to supplement the minimum test requirements and improve location resolution.

8.3 Position the sensors on the FRP and metal portions of the components to be monitored. The extent of the coverage is determined by the number of sensors used and the attenuation characteristics of the individual components, and can be verified by a simulated AE technique as indicated in Guide E 976. Record the amplitude of the simulated AE source at a distance of 12 in. (304 mm) from the sensor as a reference. Continue to move the simulated AE source away from the sensor until the amplitude is no more than 15 dB less than the reference amplitude. This will establish the maximum effective coverage of the sensor.

8.4 The mounting of sensors shall be in accordance with Practice E 569 and E 650. The couplant used shall not affect the integrity of the digger derrick.

NOTE 4—The couplant should be compatible with the digger derrick; not a possible cause of contamination. The couplant should be completely removable from the surface after testing, leaving the original surface intact.

9. AE Instrumentation System Performance Check

9.1 Performance verification shall be made with an AE simulator immediately prior to application of test load. This

simulator should be capable of producing a transient elastic wave having an amplitude representative of the AE signals to be recorded.

9.2 The AE simulator may be gas jet, pencil lead break technique or an electronically induced event or equivalent.

9.3 The detected peak amplitude of the simulated event at a fixed distance, typically 6 to 9 in. (152 to 228 mm), from each sensor shall not vary more than 6 dB from the average of all the sensors on the same type material. The detected peak amplitude of any sensor shall not exceed 90 dB to avoid saturation of amplifier(s).

10. System Calibration

10.1 Subject the AE system to a thorough calibration and functional check to verify accurate performance in accordance with the manufacturer's specification, in conjunction with Practice E 750. Perform calibration annually as a minimum in accordance with a written calibration procedure. Include in the calibration, as a minimum: calibration of threshold levels, amplitude measurement circuits, count measurement circuits, AE sensors and load measuring devices.

10.2 Subject the AE system to a routine performance check, which shall include as a minimum, verification of threshold levels and amplitude measurements. Performance checks should be conducted monthly or after 40 h of operation, whichever is more frequent.

11. Procedure

11.1 Test the digger derrick in a position such that the components indicated in Table 1 can be monitored. Ideally, this would be with the insulated boom only extended at an angle of zero degrees (horizontal). Fig. 2 shows the recommended test positions. The insulated boom test load shall be 150 % of its maximum rated capacity.

11.2 Attach the load measuring device to the load application system, which in turn shall attach to an adequate dead weight or anchor.

11.3 Loads should be applied to the actual load line used for material handling. The line may run just over the outer sheave and a loading mechanism or stiffer line attached to minimize line stretch.

11.4 All components of the load application system shall be capable of supporting the test load.

11.5 Perform the loading sequence as shown in Fig. 3.

11.6 Platforms should be tested separately in accordance with Test Method F 914.

11.7 If the unit is equipped with a jib, it should be tested separately with booms retracted so as not to require the monitoring of the digger derrick during the jib tests, except for the interface between the jib and derrick. The jib shall be tested in its fully extended position at an angle of 0-degrees. The test load shall be 150 % of its rated capacity. Where applicable the actual loadline shall be used.

11.8 If the digger derrick is rated with other load ratings or other loading positions that would cause significantly different stresses or potential for defect initiation, then it shall be tested in those positions in addition to the standard position described previously.

ASTM F 1797

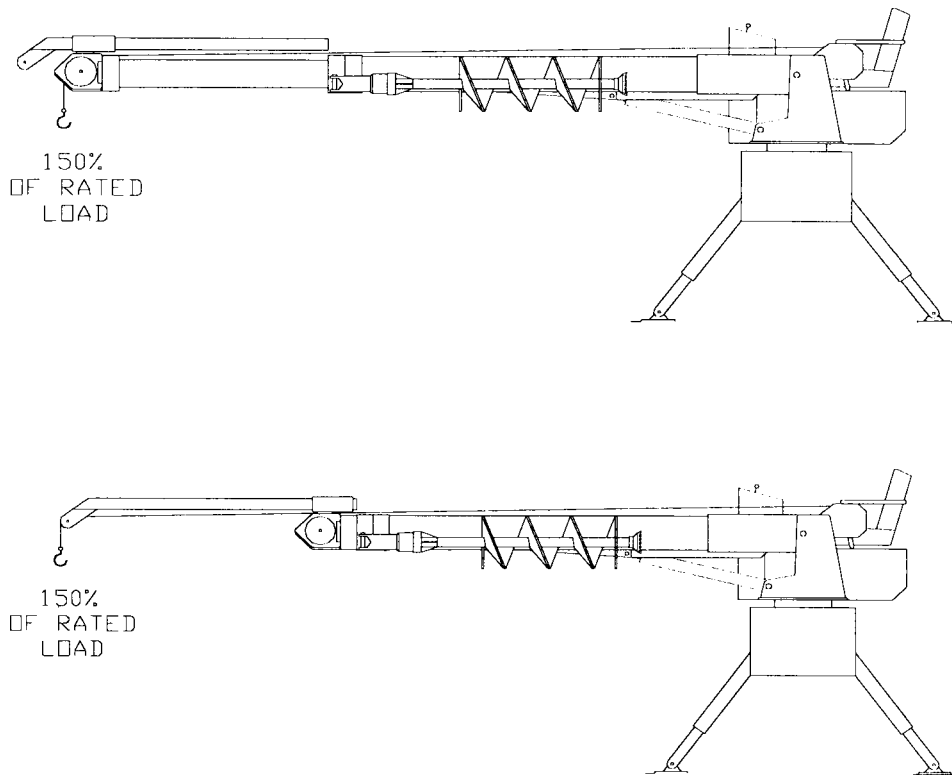

Notes (Apply To All Tests):

- (1) Position truck in most favorable stable position, on firm, level ground.
- (2) Extend outriggers.
- (3) Refer to manufacturers load charts, operational manuals, and decals before testing.
- (4) Maintain weights (test loads) within 2 ft of the ground at all times.

FIG. 2 Insulated Digger Derrick Recommended Test Positions and Test Loads

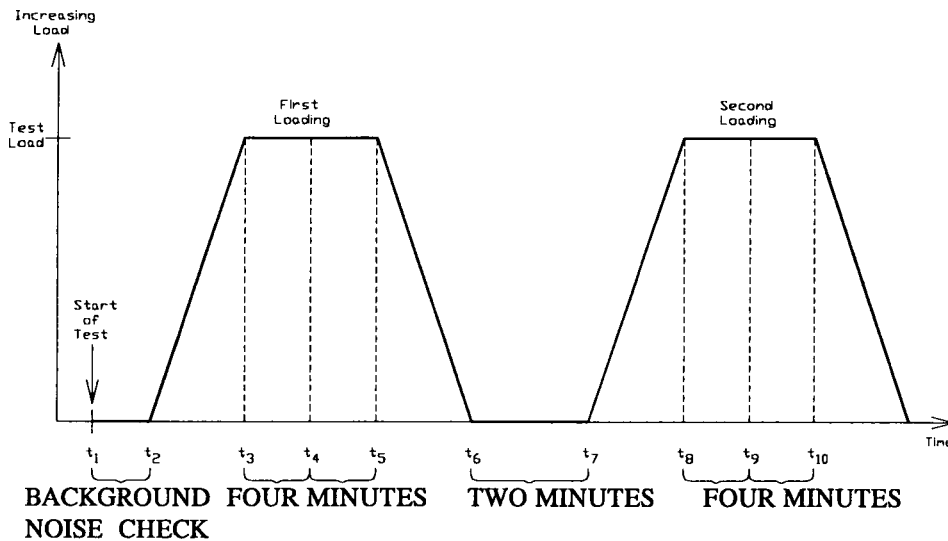

FIG. 3 Acoustic Emission Test Sequence for Insulated Digger Derrick

11.9 Pass/Fail Criteria for Acoustic Emission Testing of FRP Components:

11.9.1 The following acceptance criteria are valid only when using this test method and applied loads remain constant during hold cycles. The following AE responses from monitoring FRP components constitute acceptance:

11.9.1.1 Zero events or counts, or both, during the last 3 min of the second hold, at test load, or

11.9.1.2 Fewer total events or counts, or both, recorded during the second hold period at test load than the total events or counts, or both, recorded during the first hold period (Kaiser effect). A clear reduction in the rate of acoustic activity over both hold periods should also be observed (that is, the slope of events/time or counts/time decreases over the hold periods).

11.9.2 Acoustic responses outside the previously described parameters are unacceptable to this test method. Suitability for



service of FRP components that do not meet this test method must be carefully evaluated.

12. Report

12.1 The report shall be signed and dated by the responsible qualified personnel performing the tests. The information recorded shall be sufficient to permit complete analysis of the results.

12.2 *Test Equipment*—Instrument settings shall be included in all reports submitted for the examination. The report shall include, but is not limited to:

12.2.1 Sensor manufacturer, model number, serial numbers, nominal peak frequency response, methods of sensor attachment, and type of couplant.

12.2.2 Diagram or sketch of sensor locations including a description indicating areas of coverage.

12.2.3 Description of load application and measured test load sequence.

12.2.3.1 Identify the type of load application, that is, constant load versus time or constant displacement versus time.

12.2.3.2 Report the variation of load versus time during each of the load hold periods in pounds or percent of full load.

12.2.4 Permanent data record in the form of charts, graphs or tabulations, or combination thereof.

12.2.5 Ambient conditions during test, such as wind, temperature, rain, etc.

12.3 *Digger Derrick*—All submitted reports of the examination shall include, but not be limited to, the following information:

12.3.1 The digger derrick manufacturer, model, serial number, and year of manufacture.

12.3.2 General description including rated capacities of the boom, jibs, platforms and other attachments in the positions tested.

12.3.3 Modifications, changes, repairs and damage or suspected damage to the digger derrick.

12.4 *Other Test Information:*

12.4.1 The method used for determination of the test load.

12.4.2 A description of the test position(s) used, and

12.4.3 Any additional pertinent information.

12.5 Any departure from the procedures specified in this test method shall be adequately justified and documented in the test record.

13. Precision and Bias

13.1 Each testing agency has the responsibility of judging the acceptability of its own results. The precision of the results is a function of the procedures, facilities utilized, as well as compliance to the recommended industry state-of-the-art practices. Reproducible analysis determinations by different users can be achieved only with identical facilities and trained conscientious personnel.

ANNEX

(Mandatory Information)

A1. INSTRUMENT PERFORMANCE REQUIREMENTS

A1.1 *Sensors*—AE sensors shall be stable over the temperature range of use, and shall not exhibit sensitivity changes greater than 3 dB over this range. Sensors shall be shielded against radio frequency and electromagnetic noise interference through proper shielding practice or differential (anticoincident) element design, or both. Sensors shall have omnidirectional response, with variations not exceeding 4 dB from the peak response.

A1.1.1 High frequency sensors, used on metal components of the digger derrick, should have the primary resonant frequency at 150 kHz \pm 10 kHz. Minimum sensitivity shall be -80 dB referred to 1 V per microbar, or -40 dB for integral preamp sensors as determined by face-to-face ultrasonic swept-frequency calibration. AE sensors should not vary in sensitivity more than 3 dB from the average.

A1.1.2 Low frequency sensors, used on fiberglass components of the digger derrick, should have the primary resonant frequency at 60 kHz \pm 10 kHz. Minimum sensitivity shall be equivalent or greater than high sensitivity accelerometers designed for use at 60 kHz.

A1.1.3 Up to two sensors may be commoned into a single channel.

A1.2 *Signal Cable*—The signal cable from sensor to

preamplifier shall not exceed 6 ft (1.8 m) in length and shall be shielded against electromagnetic interference. This requirement is omitted where the preamplifier is mounted in the sensor housing, or a line-driving (matched impedance) sensor is used.

A1.3 *Preamplifier*—The preamplifier may be separate or may be mounted in the sensor housing. For sensors with integral preamplifiers, frequency response characteristics may be confined to a range consistent with the operational frequency of the sensor. If the preamplifier is of differential design, a minimum of 40 dB of common-mode noise rejection shall be provided. Unfiltered frequency response shall not vary more than 3 dB over the frequency range of 20 to 400 kHz, and over the temperature range of use.

A1.4 *Filters*—Filters shall be of the band pass or high pass type, and shall provide a minimum of -24 dB/octave signal attenuation. Filters may be located in preamplifier or post-preamplifier circuits, or may be integrated into the component design of the sensor, preamplifier, or processor to limit frequency response. Filters or integral design characteristics, or both, shall ensure that the principal processing frequency for high frequency sensors is not less than 100 kHz, and for low frequency sensors, not less than 25 kHz.

A1.5 *Power-Signal Cable*—The cable providing power to

the preamplifier and conducting the amplified signal to the main processor shall be shielded against electromagnetic noise. Signal loss shall be no more than 1 dB per 100 ft (30.4 m) of cable length. Five hundred feet (152 m) is the recommended maximum cable length to avoid excessive signal attenuation. Digital or radio transmission of signals is allowed consistent with standard practice in transmitting those signal forms.

A1.6 Main Amplifiers—The main amplifier, if used, shall have signal response with variations not exceeding 3 dB over the frequency range of 20 to 400 kHz, and temperature range of use. The main amplifier shall have adjustable gain, or an adjustable threshold for event detection and counting.

A1.7 Main Processor:

A1.7.1 General—The main processors shall have a minimum of eight independent channel inputs for signal processing of events. If mixer(s) are used, first-hit event processing for each channel must be provided.

A1.7.1.1 Independent processing of counts, events, and amplitude (per event) for each channel is preferred; but as a minimum, two active processing circuits shall process counts and amplitude information from metal and fiberglass channels independently.

A1.7.1.2 The system shall be capable of processing and storing at least 100 events/s for limited periods of time.

A1.7.2 Peak Amplitude Detection—Usable dynamic range shall be a minimum of 60 dB with 5 dB resolution over the frequency band of 20 to 400 kHz, and the temperature range of use. Not more than 2 dB variation in peak detection accuracy shall be allowed over the stated temperature range. Amplitude

values may be stated in volts or dB, but must be referenced to a fixed gain output of the system (sensor or preamp).

A1.7.3 Source Location—Source location using time difference processing between channels is optional, and may be used where it improves source identification on the structure. However, use of the source location algorithms shall not prohibit processing of individual or first-hit sensor information.

A1.7.4 Signal Outputs and Recording—The processor shall provide as a minimum outputs for permanent recording of:

A1.7.4.1 Events by channel (events versus time).

A1.7.4.2 Counts versus time or load for metal channels,

A1.7.4.3 Counts versus time or load for fiberglass channels,

A1.7.4.4 Amplitude distribution for metal channels,

A1.7.4.5 Amplitude distribution for fiberglass channels, and

A1.7.4.6 Load versus time.

NOTE A1.1—The required outputs should be based on first hit information.

A1.7.5 Load Measuring Device—The load cell or other load measuring device shall be capable of registering the loads applied during testing within its calibration range. The device shall be calibrated in a manner and at intervals recommended by the manufacturer's specifications. The percent error for loads within the loading range of the load cell and readout shall not exceed $\pm 1.0\%$ of reading. In load readouts that possess multiple-capacity ranges, the verified loading of each range shall not exceed $\pm 1.0\%$ of reading. An electronic output of the load measuring device, proportional to applied load, shall be properly conditioned and amplified to match the requirements of the recording device used.

The American Society for Testing and Materials takes no position respecting the validity of any patent rights asserted in connection with any item mentioned in this standard. Users of this standard are expressly advised that determination of the validity of any such patent rights, and the risk of infringement of such rights, are entirely their own responsibility.

This standard is subject to revision at any time by the responsible technical committee and must be reviewed every five years and if not revised, either reapproved or withdrawn. Your comments are invited either for revision of this standard or for additional standards and should be addressed to ASTM Headquarters. Your comments will receive careful consideration at a meeting of the responsible technical committee, which you may attend. If you feel that your comments have not received a fair hearing you should make your views known to the ASTM Committee on Standards, at the address shown below.

This standard is copyrighted by ASTM, 100 Barr Harbor Drive, PO Box C700, West Conshohocken, PA 19428-2959, United States. Individual reprints (single or multiple copies) of this standard may be obtained by contacting ASTM at the above address or at 610-832-9585 (phone), 610-832-9555 (fax), or service@astm.org (e-mail); or through the ASTM website (www.astm.org).