



Designation: **F 1826 – 9700**

Standard Specification for Telescoping Live Live Line and Measuring Telescoping Tools¹

This standard is issued under the fixed designation F 1826; the number immediately following the designation indicates the year of original adoption or, in the case of revision, the year of last revision. A number in parentheses indicates the year of last reapproval. A superscript epsilon (ϵ) indicates an editorial change since the last revision or reapproval.

1. Scope

1.1 This specification covers mechanical and electrical testing and acceptance criteria for telescoping live line tools.

1.1.1 A tool designed only for use as a measuring device need not comply with mechanical strength requirements of this specification.

1.2 The use and maintenance of this equipment is beyond the scope of this specification.

1.3 This specification does not cover multiple section ~~measuring sticks~~ or extendable section clampsticks.

1.4 The values stated in SI units are to be regarded as the standard. The inch-pound units given in parentheses are provided for information only.

1.5 The following safety hazards caveat pertains to Section 9 only. *This standard does not purport to address all of the safety concerns, if any, associated with its use. It is the responsibility of the user of this standard to establish appropriate safety and health practices and determine the applicability of regulatory limitations prior to use.*

2. Referenced Documents

2.1 *ASTM Standards:*

D 149 Test Method for Dielectric Breakdown Voltage and Dielectric Strength of Solid Electrical Insulating Materials at Commercial Power Frequencies²

¹ This specification is under the jurisdiction of ASTM Committee F-18 on Electrical Protective Equipment for Workers and is the direct responsibility of Subcommittee F18.35 on Tools and Equipment.

Current edition approved Oct. 10, 1997; 2000. Published February 1998. Originally published as F 1826-97. Last previous edition F 1826-97.

~~F-711 Specification for Fiberglass-Reinforced Plastic (FRP) Rod and Tube Used in Live Line Tools³~~
~~F-819 Definitions~~ 819 Definitions of Terms Relating to Electrical Protective Equipment for Workers³

² *Annual Book of ASTM Standards*, Vol 10.01.

³ *Annual Book of ASTM Standards*, Vol 10.03.

3. Terminology

3.1 *Definitions*— Terminology used in this specification is in accordance with Definitions F 819.

3.2 *Definitions of Terms Specific to This Standard:*

3.2.1 *acceptance test, n*—one made at the option of the purchaser to verify that a product meets design criteria.

3.2.2 *design test, n*—one made on a sample treated as representative of an industrial product. These tests generally will not be repeated in quantity production.

3.2.3 *dimensional check, n*—measurements made to verify that a product complies with the dimension stated by the manufacturer.

3.2.4 *hydrophobic, adj*—lacking affinity for water.

3.2.5 *routine test, n*—a type of test made regularly on production material.

3.2.6 *telescoping live line tool, n*—an extendable multiple section FRP tool designed to carry an attachment to perform mechanical tasks.

3.2.7 *telescoping measuring tool, n*—an extendable multiple section FRP tool designed only to measure vertical heights.

3.2.8 *visual inspection, n*—a visual check made to detect manufacturing defects.

4. Significance and Use

4.1 This specification shall be used for design, routine, and acceptance testing of telescoping live line and measuring telescoping tools.

5. Ordering Information

5.1 Include the following information when ordering telescoping live line or measuring tools, or both:

5.1.1 Quantity.

5.1.2 Catalog number.

NOTE 1—Live line tools may also be designed as a measuring tool.

5.1.3 Tested to meet ASTM Specification F 1826 design tests.

6. Workmanship, Finish, and Appearance

6.1 The external and internal surfaces shall have hydrophobic abilities.

6.2 The external and internal surfaces shall be free of any abrasions, scratches, blemishes and surface defects that may capture an impurity and impair the dielectric integrity of the product.

6.3 After a finish coating, such as paint, has been applied, the material shall meet all physical, electrical, and mechanical properties.

6.4 Measuring units on telescoping tools shall be readable and clearly legible on all sections designed for measuring.

7. Sampling

7.1 *Design Test*— Perform the test on a minimum of three samples. The design test will be used to qualify a specific item and normally will not be repeated during production.

7.2 *Routine Test*— Perform the test on all pieces delivered to the purchaser.

7.3 *Acceptance Tests*— A test made at the option of the purchaser.

8. Tests to Be Conducted

8.1 *Mechanical:*

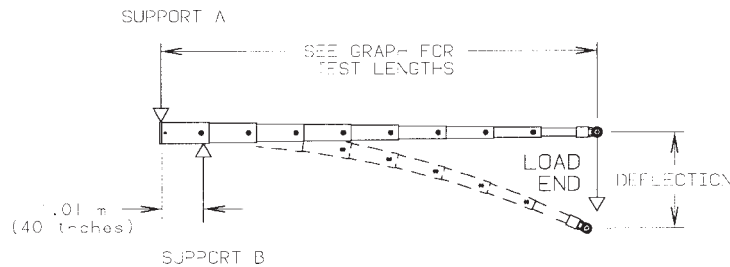

FIG. 1 Horizontal Test Set-Up

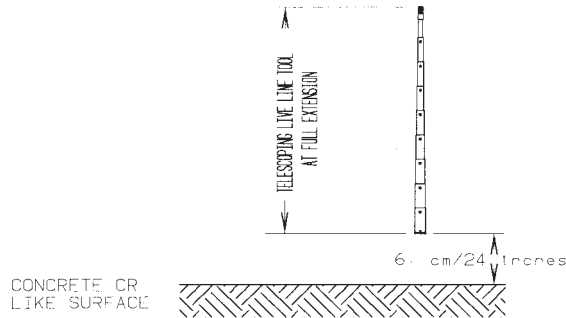

FIG. 2 Position of Stick Prior to Release for Free Fall Test

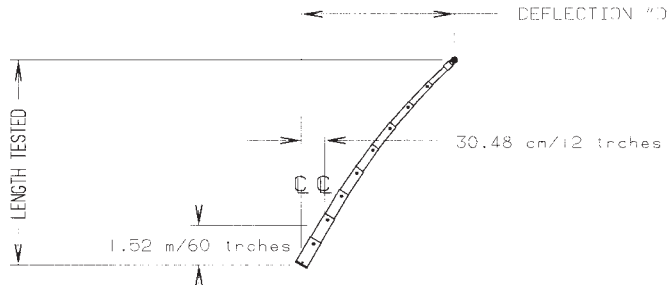
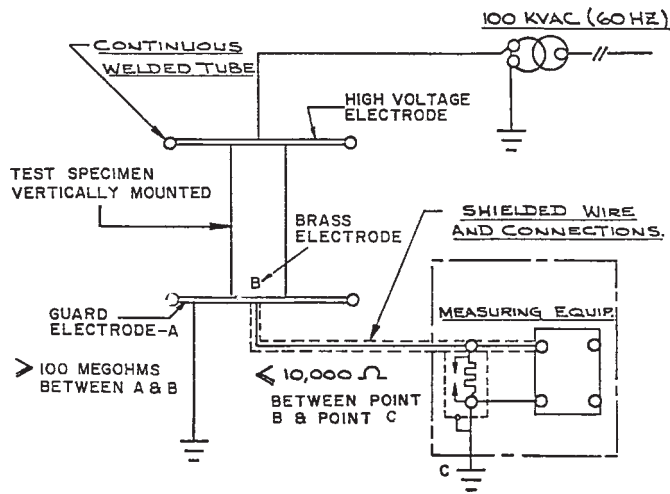

FIG. 3 Block Edge of Telescoping Stick to Obtain Correct 30.48 cm (12 in.) Centerline to Centerline Measurement

ELECTRICAL TEST CARRIED OUT DRY AND AFTER MOISTURE ABSORPTION.



NOTE 1—For details of Fig. 4, see Figs. 5-10.

FIG. 4 Typical AC Test Set-Up

Test	Type
Visual	Routine/Acceptance
Dimensional	Design/Acceptance
Horizontal Bending Deflection	Design
Free Fall Impact	Design
Tension	Design
Vertical Deflection	Design

8.2 Electrical:

Test	Type
Leakage Current	Design
Withstand	Routine/Acceptance

9. Mechanical Test Methods

9.1 *Visual Inspection*—In accordance with the manufacturer’s recommendation, a visual inspection shall be made to detect constructional defects, for example, evidence of faulty bonding between fibers and resin, air bubbles, foreign bodies, or particles. Check all operational components for fit and function.

9.2 *Dimensional Values*—The manufacturer, upon request by the purchaser, shall furnish product dimensional values to the customer.

9.3 *Mechanical Tests:*

9.3.1 *Horizontal Bending Deflection Tests*—When extended to the maximum length, a telescoping live line tool shall be placed horizontally in a testing device as shown in Fig. 1.

9.3.1.1 The distance between supports is 1.01 m (40 in.). Support B serves only as a fulcrum and can be a cradle to mate with the pole diameter of the location.

9.3.1.2 With telescoping live line tool fully extended and no weight added, the deflection shall not exceed the values specified in Table 1.

9.3.1.3 With telescoping live line tool fully extended, attach an external load of 2.27 kg (5 lb) to the load end. See Fig. 1. The deflection shall not exceed the values specified in Table 1.

9.3.2 *Free Fall Impact Test*—The telescoping tool shall be extended to its maximum length and shall be positioned vertically. The bottom of the tool shall be located 61 cm (24 in.) above a concrete or like surface. When released, the downward movement of the tool shall not be restricted or slowed. The tool shall not collapse or reveal significant signs of damage to the lock devices and shall display no sign of cracking of the FRP tubes. See Fig. 2-2.

9.3.3 *Tension Test*—When extended to the maximum length, a telescoping live line tool shall withstand a tensile load of 136.36 kg (300 lb) along its axis for 10 min without damage. The tool shall not elongate or show any sign of deterioration.

9.3.4 *Vertical Deflection Test*—The telescoping live line tool shall be placed vertically in a testing device such that the bottom section can be tilted. See Fig. 3-3. The tilt shall be 30.48 cm (12 in.) from vertical at 152 cm (60 in.) from the bottom of the tool. Without additional restraint, the deflection *D* at the top of the fully extended tool shall not exceed the values given in Table 2.

10. Electrical Design Test Specimen Preparation

10.1 Three telescoping tools shall each have a specimen cut from each telescoping section. Each specimen shall be 300 mm (12 in.) in length.

10.2 *Conditioning Prior to Electrical Tests:*

10.2.1 Prior to the first or initial electrical test, the sample shall be cleaned inside and out with a suitable solvent, as recommended by the manufacturer, specifically a solvent that neither destroys the materials from which the tube is made nor leaves any residue on the surface of the sample.

10.2.2 All tests shall be made before and after exposure to moisture conditioning, as specified, using 60 Hz voltage.

10.3 *Moisture Conditioning:*

10.3.1 *Before Current Measurement* —After initial cleaning (see 10.2.1), the specimen shall remain in the ambient atmosphere of the test premises for at least 24 h.

10.3.2 Upon completion of the before-moisture conditioning electrical test (*I*₁), the specimen shall then be placed in a suitable chamber and undergo the following conditioning prior to the after-moisture conditioning electrical test, (*I*₂). See Table 3.

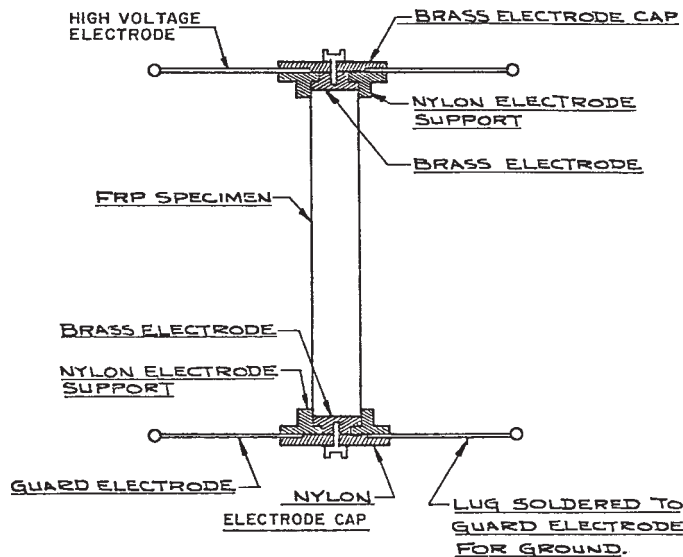

FIG. 5 Assembly Detail

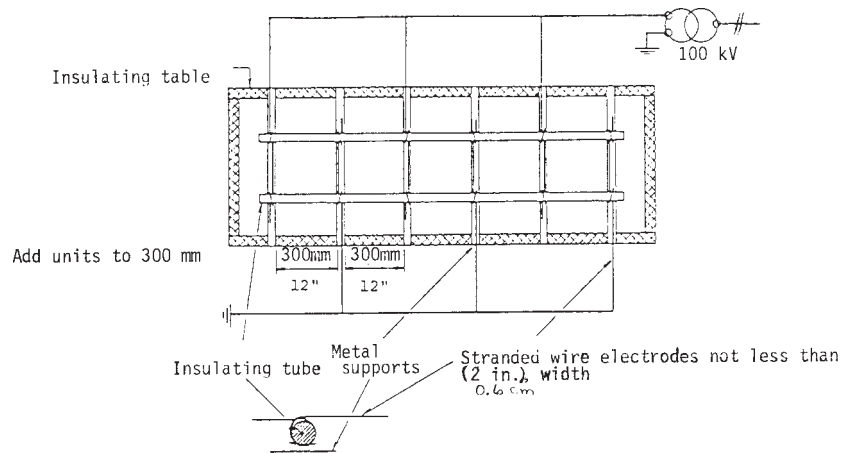

FIG. 11 Typical Test Arrangement for Electrical Withstand Acceptance Test

TABLE 1 Telescoping Live Line Tool Horizontal Bending Deflection Test Acceptable Values of Deflection Versus Extended Length

Extended Length	No Weight Added	2.27 kg (5 lb) Added
2.4 m (8 ft)	1.3 cm (½ in.)	9.2 cm (3⅝ in.)
3.7 m (12 ft)	9 cm (3¾ in.)	0.4 m (1 ft 3⅝ in.)
4.9 m (16 ft)	26.7 cm (10½ in.)	0.9 m (2 ft 11¼ in.)
6.0 m (20 ft)	0.53 m (1 ft 9 in.)	1.7 m (5 ft 6½ in.)
7.6 m (25 ft)	0.95 m (3 ft 1½ in.)	2.4 m (8 ft 0 in.)
9.1 m (30 ft)	1.5 m (5 ft 1 in.)	3.1 m (10 ft 10⅞ in.)
10.7 m (35 ft)	2.3 m (7 ft 7 in.)	4.4 m (14 ft 4 in.)
12.2 m (40 ft)	3.15 m (10 ft 4 in.)	5.6 m (18 ft 4 in.)

TABLE 2 Telescoping Live Line Tool Vertical Deflection Test (No Weight Added)

Extended Length	No Weight Added
2.4 m (8 ft)	0.53 m (1 ft 9 in.)
3.7 m (12 ft)	0.83 m (2 ft 8½ in.)
4.9 m (16 ft)	1.1 m (3 ft 8½ in.)
6.1 m (20 ft)	1.6 m (5 ft 4½ in.)
7.6 m (25 ft)	2.0 m (6 ft 8 in.)
9.1 m (30 ft)	2.5 m (8 ft 2 in.)
10.7 m (35 ft)	3.1 m (10 ft 1½ in.)
12.2 m (40 ft)	3.7 m (12 ft 3 in.)

TABLE 3 Moisture Conditioning Values

Time:	168 h
Temperature:	23 ± -2°C
Relative humidity:	93 % or greater

11. Electrical Test Methods

11.1 *Electrical Tests*— The test apparatus shall be designed to provide the operator full protection in the performance of duties and provide reliable means of de-energizing and grounding the high-voltage circuit.

11.1.1 During the course of the testing, there shall be no sign of flashover or puncture on any of the samples.

11.1.2 The ambient temperature for the test location shall not be lower than 20°C (68°F).

11.2 *Electrical Design Test*—A typical test setup is shown in Fig. 4. Details are shown in Figs. 5-10. The measuring equipment should not be less than 1.8 m (6 ft) from the high-voltage electrode. Shield and ground the assembly of connection for the measuring equipment. Vertically mount the test specimen at least 0.9 m (3 ft) above the floor on an insulating support. Apply the voltage of 100 kV rms at 60 Hz between the electrodes, in accordance with Test Method D 149 at a maximum voltage rise of 3000 V/s. Measure the current passing over or through the test specimen in rms values by passing it through a known resistance.

11.2.1 The current I_1 is the maximum dielectric current measured with an alternating voltage of 100 kV rms 60 Hz applied between the electrodes for one minute.

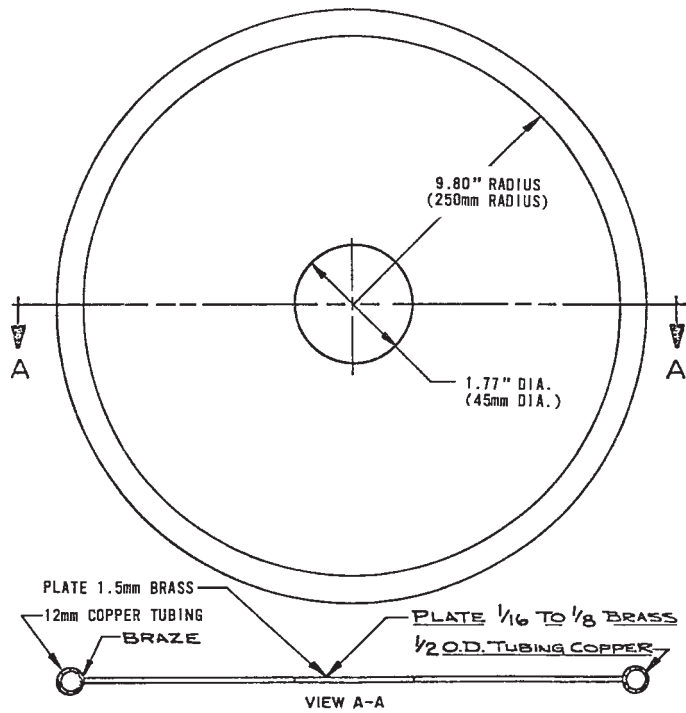

2 REQUIRED

FIG. 6 Electrode Detail

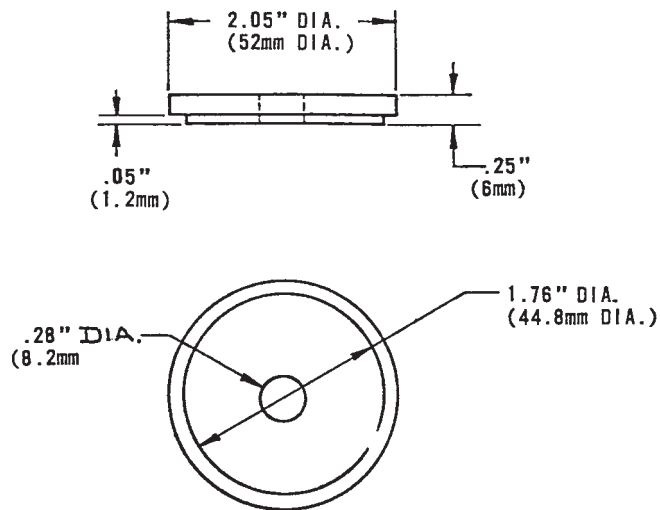

1 REQ'D NYLON

1 REQ'D BRASS

FIG. 7 Electrode Cap Detail

11.2.2 After moisture conditioning and a light wiping with a dry cloth, the current I_2 is measured under the same conditions as was I_1 .

11.2.3 Locate the specimen in the same relative position to earth. The high-potential end of the sample shall be the same for both tests.

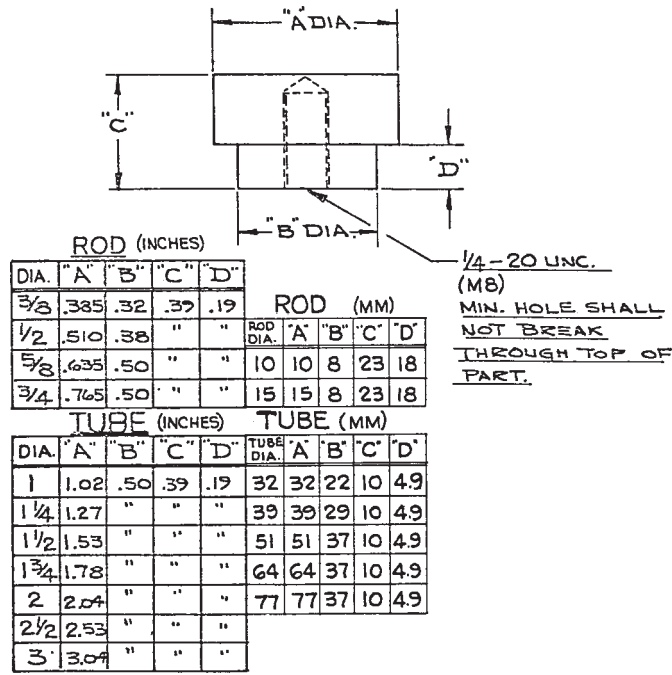

2 REQ'D EACH SIZE

BRASS

FIG. 8 Brass Electrode Detail

11.2.4 *Test Results*— The currents (I_1) measured must be less than the values in Table-4. The difference between I_1 and I_2 shall be less than 20 μ A.

11.3 *Electrical Withstand Test*—The typical test setup is shown in Fig. 11. Horizontally mount the test specimen above the floor or ground plane at a distance sufficient to prevent flashover. The electrodes shall be spaced 30.48 cm (12 in.) apart. An alternative test method may be used upon agreement between manufacturer and purchaser. See Appendix X1.

11.3.1 During the electrical withstand test, the tubes shall be subjected to an alternating voltage of 100 kV rms/ft at 60 Hz power frequency in accordance with Test Method D 149 at a maximum voltage rise of 3000 V/s. The test voltage shall be applied between electrodes for five minutes.

11.3.2 During the course of the testing, there shall be no sign of flashover, puncture, tracking, or erosion on the surface of any sample. There shall be no perceptible temperature rise of any sample.

12. Marking

12.1 Finished telescoping live line or measuring tools, or both, shall carry the following information affixed to the item in a manner that does not affect the performance:

12.1.1 Name of manufacturer,

12.1.2 Month and year of manufacture, and

12.1.3 That the product meets the requirement and bears the designated number of this specification.

13. Keywords

13.1 telescoping live line tools; telescoping measuring tools

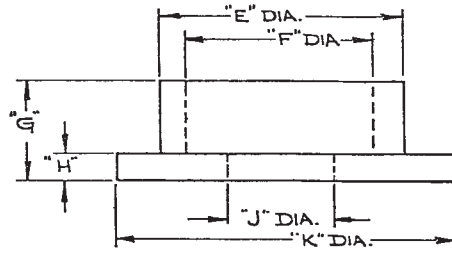

ROD (INCHES)							ROD (mm)						
DIA.	"E"	"F"	"G"	"H"	"J"	"K"	DIA.	"E"	"F"	"G"	"H"	"J"	"K"
3/8	.80	.41	.78	.20	.34	2.05	10	20	10.4	20	5	8.2	52
1/2	.90	.53	"	"	.40	"	15	25	15.04	20	5	8.2	52
5/8	1.10	.66	"	"	.52	"							
3/4	1.20	.79	"	"	.52	"							

TUBE (INCHES)							TUBE (mm)						
DIA.	"E"	"F"	"G"	"H"	"J"	"K"	DIA.	"E"	"F"	"G"	"H"	"J"	"K"
1	1.45	1.04	.78	.20	.52	2.05	32	42	32.2	20	5	22.2	52
1 1/4	1.70	1.29	"	"	"	"	39	49	39.2	20	5	29.2	52
1 1/2	1.95	1.55	"	"	"	"	51	61	51.2	20	5	37.2	61
1 3/4	2.20	1.80	"	"	"	"	64	74	64.2	20	5	37.2	74
2	2.45	2.06	"	"	"	2.45	77	87	77.2	20	5	37.2	87
2 1/2	2.95	2.55	"	"	"	2.95							
3	3.45	3.06	"	"	"	3.45							

2 REQ'D EACH SIZE
NYLON

FIG. 9 Nylon Electrode Support Detail

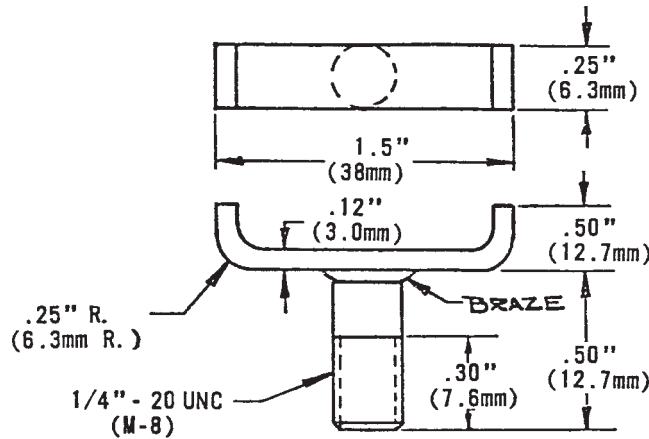

2 REQ'D BRASS

FIG. 10 Brass Screw Detail

TABLE 4 Leakage Current I_1 ^A

Type	Outside Diameter		Leakage Current I_1 μA
	mm	in.	
Tube	> ^B 0 – 25.4	> 0 – 1	5
	> 25.4 – 31.8	> 1 – 1 ¼	6
	> 31.8 – 38.1	> 1¼ – 1½	8
	> 38.1 – 44.5	> 1½ – 1¾	9
	> 44.5 – 50.8	> 1¾ – 2	10
	> 50.8 – 63.5	> 2 – 2½	12
	> 63.5 – 76.2	> 2½ – 3	14

^A Values listed for maximum I_1 are based on pole constructed of a relatively thin wall and filled internally with foam or hollow tube. Some special applications require a thicker wall, denser foam, or different materials, which could change the dielectric constant of the test setup and consequently I_1 . Tubes, such as these, will still meet the requirements of this specification if the dry leakage is less than twice the listed maximum value of I_1 in the table.

^B > = one set not two.

APPENDIX

(Nonmandatory Information)

X1. Alternative Electrical Withstand Test

X1.1 The test apparatus shall be designed to provide the operator full protection in the performance of duties and provide reliable means of de-energizing and grounding the high voltage circuit.

X1.2 The typical test set-up is shown in Fig. X1.1 and Fig. X1.2. The necessary equipment should be shielded adequately to provide accurate readings. The test fixture should be enclosed for worker protection and equipped with an exhaust fan to provide a stable atmosphere. A drive mechanism should be utilized to ensure a uniform rate of feed. The feed rate shall be proportional to the response time of the metering circuit, that is, it should be run slow enough that maximum readings are obtained. At no time should this rate of feed exceed 12.2 m/min (40 ft/min).

X1.3 With 150 mm (6 in.) electrode spacing, the applied voltage will be 50 kV. The equipment shall be designed such that at flashover, excessive leakage current will disable the drive mechanism so that intentional action on the part of the operator is required to reset the equipment.

X1.4 Acceptable values of leakage current shall be a rise above ambient of less than I_1 as listed in Table 4.

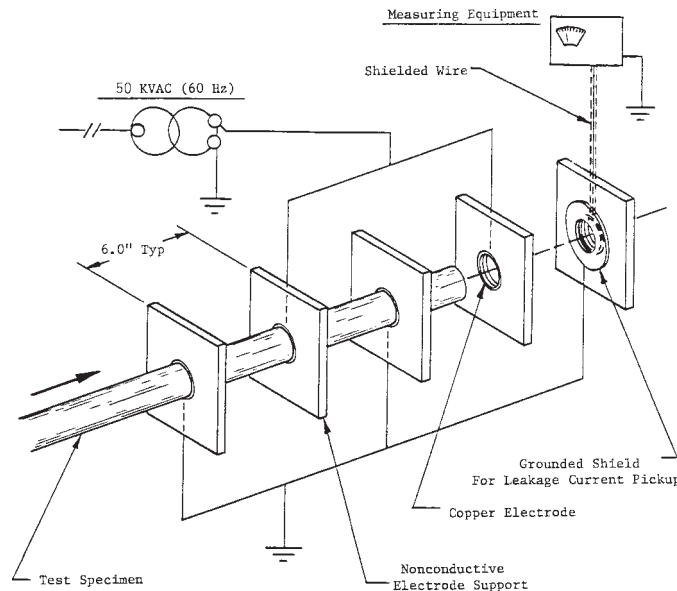

FIG. X1.1 Alternative Electrical Test Set-Up

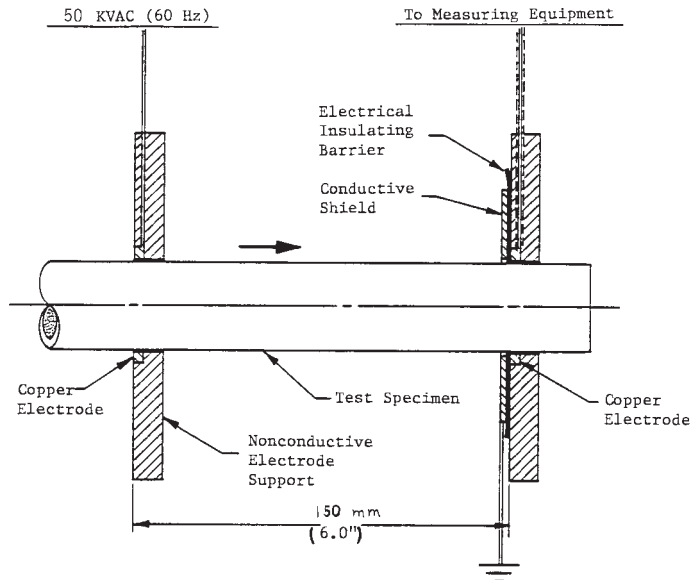

FIG. X1.2 Alternative Electrical Test Set-Up

ASTM International takes no position respecting the validity of any patent rights asserted in connection with any item mentioned in this standard. Users of this standard are expressly advised that determination of the validity of any such patent rights, and the risk of infringement of such rights, are entirely their own responsibility.

This standard is subject to revision at any time by the responsible technical committee and must be reviewed every five years and if not revised, either reapproved or withdrawn. Your comments are invited either for revision of this standard or for additional standards and should be addressed to ASTM International Headquarters. Your comments will receive careful consideration at a meeting of the responsible technical committee, which you may attend. If you feel that your comments have not received a fair hearing you should make your views known to the ASTM Committee on Standards, at the address shown below.

This standard is copyrighted by ASTM International, 100 Barr Harbor Drive, PO Box C700, West Conshohocken, PA 19428-2959, United States. Individual reprints (single or multiple copies) of this standard may be obtained by contacting ASTM at the above address or at 610-832-9585 (phone), 610-832-9555 (fax), or service@astm.org (e-mail); or through the ASTM website (www.astm.org).