



Standard Specification for Fiberglass-Reinforced Plastic (FRP) Rod and Tube Used in Live Line Tools¹

This standard is issued under the fixed designation F 711; the number immediately following the designation indicates the year of original adoption or, in the case of revision, the year of last revision. A number in parentheses indicates the year of last reapproval. A superscript epsilon (ϵ) indicates an editorial change since the last revision or reapproval.

1. Scope

1.1 This specification covers insulating rods and foam-filled tubes made from fiberglass-reinforced plastic (FRP) that are intended for use in live line tools.

1.2 This specification does not include insulating foam-filled tubes and rods from other materials. Specifications for fittings and attachments to rods and foam-filled tubes for complete tools are not covered in this specification.

1.3 This specification establishes the technical characteristics that the tubes and rods must satisfy.

1.4 The following safety hazards caveat pertains only to the test method portion, Section 12, of this specification. *This standard does not purport to address all of the safety concerns, if any, associated with its use. It is the responsibility of the user of this standard to establish appropriate safety and health practices and determine the applicability of regulatory limitations prior to use.*

2. Referenced Documents

2.1 ASTM Standards:

D 149 Test Method for Dielectric Breakdown Voltage and Dielectric Strength of Solid Electrical Insulating Materials at Commercial Power Frequencies²

D 638 Test Method for Tensile Properties of Plastics³

D 695 Test Method for Compressive Properties of Rigid Plastics³

3. Terminology

3.1 Definitions of Terms Specific to This Standard:

3.1.1 *acceptance test*—a type of test made at the option of the purchaser.

3.1.2 *design test*—a type of test made on a sample treated as representative of an industrial product. These tests will not generally be repeated in quantity production.

3.1.3 *insulating tubes and rods*—fiberglass-reinforced plastic (FRP) products manufactured using processes so that the

tubes and rods produced will meet the electrical and mechanical tests prescribed in this specification.

3.1.4 *interior foam-filled tube*—homogeneous unicellular thermosetting foam filling with closed cells blown with non-combustible gases. The foam filling shall be bonded to the interior tube wall. The foam filling should be free of voids, separations, holes, cracks, etc.

3.1.5 *routine test*—a type of test made regularly on production material.

3.1.6 *visual inspection*—a visual check made to detect constructional defects.

4. Ordering Information

4.1 *Outside Diameter Sizes*—Foam-filled FRP tube and solid FRP rod shall meet the outside diameter dimensions shown in Table 1. The tolerances shown will assist in ensuring interchangeability with interfacing equipment.

4.2 Inspection of the material shall be agreed upon between the purchaser and the seller as part of the purchase contract.

5. Materials and Manufacture

5.1 Except for those test methods leading to destruction, neither the FRP tube, foam, or the bond between them shall deteriorate during the prescribed mechanical and electrical tests of this specification.

6. Physical Requirements

6.1 The materials shall conform to the diameters prescribed in Table 1 for tube and rod.

6.2 The standard sizes listed by nominal diameter are recommended and do not preclude the manufacture of other sizes or shapes.

7. Weight

7.1 It has not been found necessary to specify the weight of the product produced under this specification in order for it to comply with performance requirements.

8. Workmanship, Finish, and Appearance

8.1 The external surface shall be uniform, symmetrical, and free of abrasions, scratches, blemishes, and surface defects.

8.2 Any defect that may capture an impurity or impair the dielectric integrity of the product shall be cause for rejection.

¹ This specification is under the jurisdiction of ASTM Committee F18 on Electrical Protective Equipment for Workers and is the direct responsibility of Subcommittee F18.35 on Tools and Equipment.

Current edition approved May 10, 2002. Published July 2002. Originally published as F 711 – 81. Last previous edition F 711 – 00¹.

² *Annual Book of ASTM Standards*, Vol 10.01.

³ *Annual Book of ASTM Standards*, Vol 08.01.

TABLE 1 Standard Tube and Rod Outside Diameters

TYPE	Nominal Diameter		Min Diameter		Max Diameter	
	in.	(mm)	in.	(mm)	in.	(mm)
Tube	1	(25.4)	0.98	(24.9)	1.02	(25.9)
	1¼	(31.8)	1.22	(31.0)	1.27	(32.3)
	1½	(38.1)	1.47	(37.3)	1.53	(38.9)
	1¾	(44.5)	1.73	(43.9)	1.78	(45.2)
	2	(50.8)	1.97	(50.0)	2.04	(51.8)
	2½	(63.5)	2.47	(62.7)	2.54	(64.5)
Rod	3	(76.2)	2.97	(75.3)	3.04	(77.2)
	¾	(9.5)	0.369	(9.4)	0.385	(9.8)
	½	(12.7)	0.490	(12.4)	0.510	(13.0)
	⅝	(15.9)	0.610	(15.5)	0.635	(16.1)
	¾	(19.1)	0.720	(18.3)	0.765	(19.4)

8.3 FRP rod or tube material after which a finish coating, such as paint, is applied must meet all physical, electrical, and mechanical requirements.

9. Sampling

9.1 Design Test—Perform the test on a minimum of three samples only when changes are made to a new or existing design of the product that may affect the mechanical and electrical characteristics.

9.1.1 The design test will be used to qualify a specific item and normally will not be repeated during production.

9.2 Sample Test—A test specimen shall consist of one or more items, dependent on 1 % of the lot being tested.

9.2.1 A lot is represented either by all items produced in one production run or in one shipment.

9.2.2 Lots of new, unused items shall have test specimens selected at random.

9.3 Routine Test—Perform the test on all pieces delivered to the purchaser.

9.4 Acceptance Test—A test made at the option of the purchaser.

10. Conduct of Tests on Samples

10.1 Mechanical:

Test	Type	Material
Wicking	design	tube
Bending deflection	design	tube
Horizontal crush	design	tube
Tension	acceptance	tube
	design	tube
	design	rod
Shear	design	tube
Compression	design	rod
Modulus of elasticity (tension)	design	rod
Mechanical aging (flexure)	design	tube
	design	rod
	design	tube
	design	rod
Visual	acceptance	tube
	acceptance	rod
	acceptance	tube
	acceptance	rod
Dimensional	routine	tube
	routine	rod

10.2 Electrical:

Test	Type	Material
Dielectric current (leakage) (before moisture conditioning)	design	rod
Dielectric current (leakage) (after moisture conditioning)	design	tube
	design	rod
	design	tube

Withstand (either method 1 or 2)

routine
routine
rod
tube

11. Number of Tests and Samples (Three each)

11.1 Tubes:

11.1.1 Wicking Test—Three samples, each 1-in. (25-mm) long.

11.1.2 Bending Deflection Test— 8 ft, 5 in. (2.6 m) or longer. See Fig. 13.

11.1.3 Horizontal Crush Test—Three diameters long. See Fig. 14.

11.1.4 Tension Test—12-in. (300-mm) long, prepared in accordance with Fig. 1 and Test Method D 638.

11.1.5 Shear Test— 4-in. (100-mm) long, prepared in accordance with Fig. 2.

11.1.6 Electrical Tests—12-in. (300-mm) long, prepared in accordance with Section 12.

11.2 Rod:

11.2.1 Compression Test (Applicable to solid rod only)— 4-ft (1.2-m) long, prepared in accordance with Test Method D 695.

11.2.2 Modulus of Elasticity (Tension) (Applicable to solid rod only)— 4 ft (1.2 m) long, prepared in accordance with Test Method D 638.

11.3 Rod and Tube Mechanical Aging Tests:

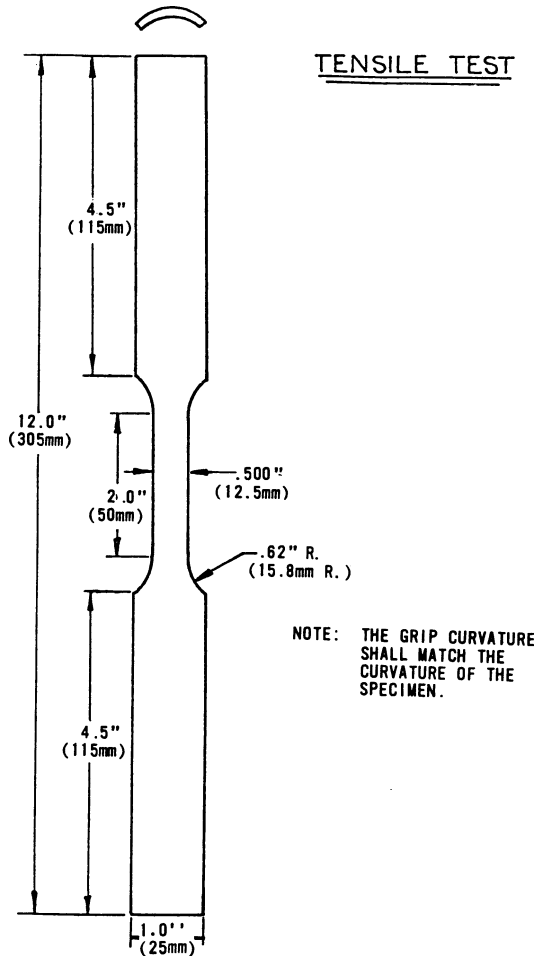

FIG. 1 Tension Test

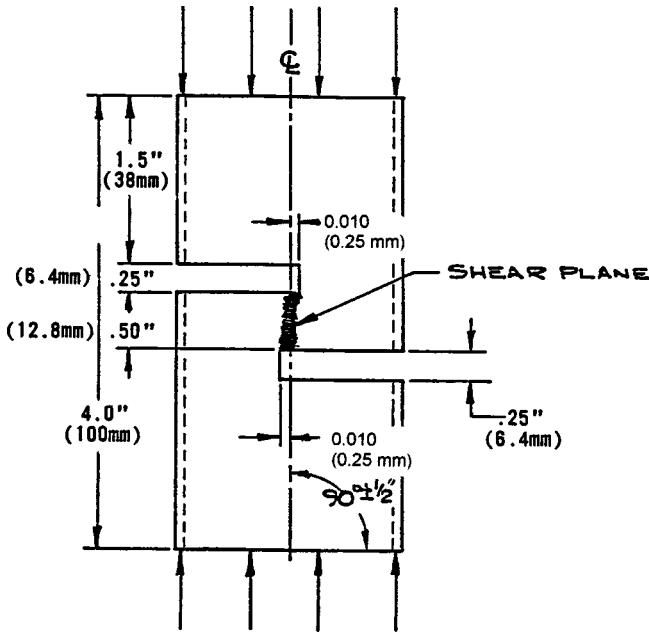

FIG. 2 Shear Test

11.3.1 *Flexure*—Rod, 4 ft (1.2 m) or tube, 8 ft (2.4 m) in length.

12. Test Methods

12.1 *Visual Inspection*—Make a visual check to detect manufacturing defects (for example, evidence of faulty bonding between fibers and resin, air bubbles, foreign bodies, or particles).

12.2 *Electrical Tests*—The test apparatus shall be designed to provide the operator full protection in the performance of his duties and provide reliable means of de-energizing and grounding the high voltage circuit.

12.2.1 During the course of the testing, there shall be no sign of flashover or puncture on any of the samples.

12.2.2 The ambient temperature for the test location shall not be lower than 60°F (16°C).

12.2.3 Prior to the first or initial electrical test, the sample shall be cleaned with a suitable solvent as recommended by the manufacturer (specifically a solvent that neither destroys the materials from which the tube or rod is made nor leaves any residue on the surface of the sample).

12.2.3.1 After initial cleaning, the sample shall remain in the ambient atmosphere of the test premises for at least 24 h.

12.2.4 *Electrical Design Test*—The sample for the dielectric test shall be 12 in. (300 mm) in length.

12.2.4.1 The electrical design tests shall be made before and after exposure to moisture conditions, as specified, using 60-Hz voltage.

12.2.4.2 A typical test setup is shown in Fig. 3. Details are shown in Figs. 4-9. The measuring equipment should not be less than 6 ft (1.8 m) from the high-voltage electrode. Shield and ground the assembly for the measuring equipment. Vertically mount the test specimen at least 3 ft (0.9 m) above the floor on an insulating support. Apply the voltage of 100 kV rms at 60 Hz between the electrodes, in accordance with Test Method D 149 at a maximum voltage rise of 3000 V/s. Measure the current passing over or through the test specimen in rms values by passing it through a known resistance.

(a) The current I_1 is the maximum dielectric current measured with an alternating voltage of 100 kV rms 60 Hz applied between the electrodes for 1 min.

(b) Upon completion of the before-moisture conditioning electrical test (I_1), the sample shall then be placed in a suitable chamber and undergo the following conditioning prior to the after-moisture conditioning electrical test, (I_2).

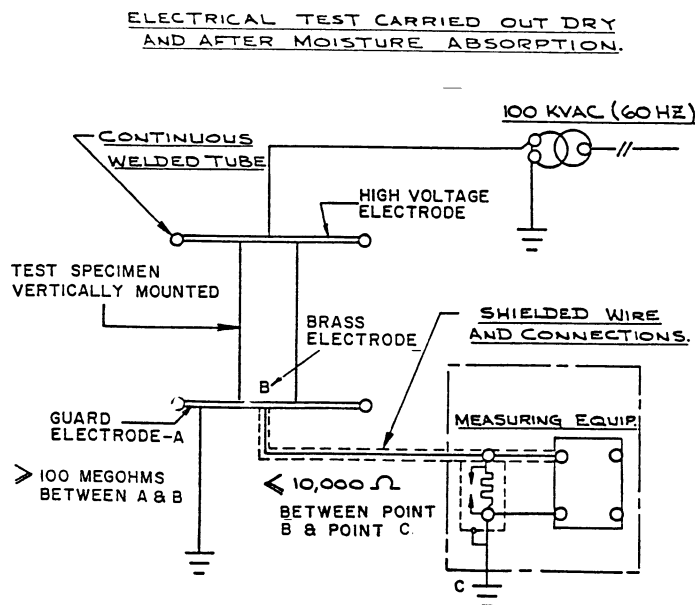

NOTE 1—For details of Fig. 3 see Figs. 4-9.

FIG. 3 Typical AC Test Set Up

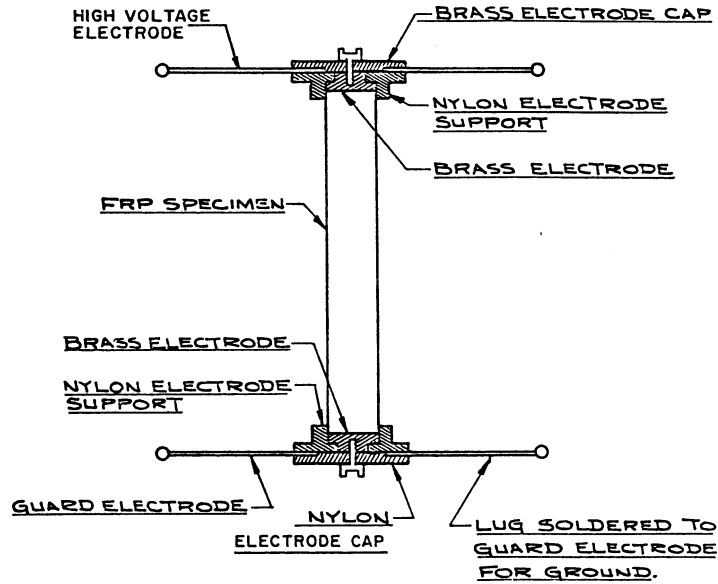
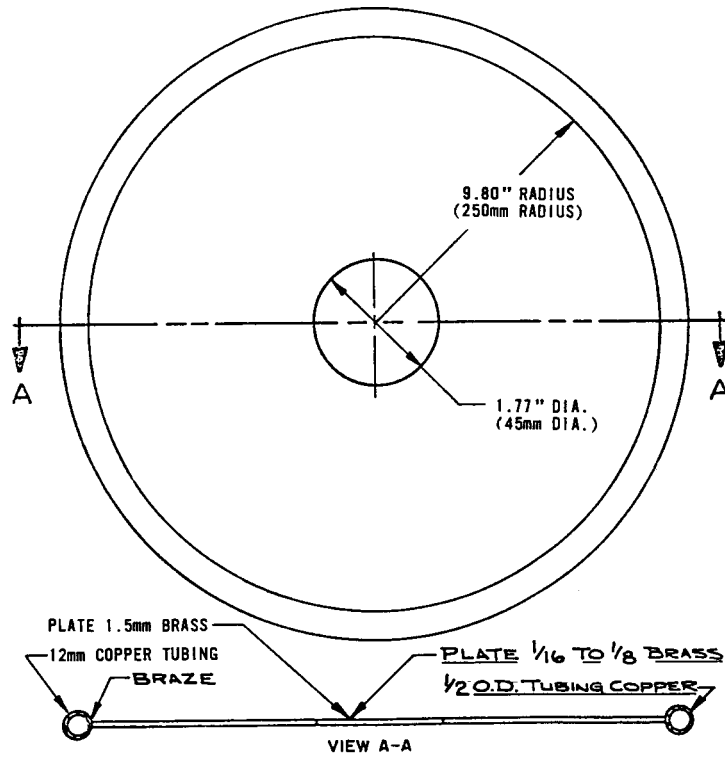

FIG. 4 Assembly Detail



2 REQUIRED

FIG. 5 Electrode Detail

Time: 168 h
 Temperature: 23 ± 4°C
 Relative humidity: 93 %, or greater

(d) Locate the specimen in the same relative position to earth; the high-potential end of the sample shall be the same for both tests.

(c) After moisture conditioning and a light wiping with a dry cloth, the current I_2 is measured under the same conditions as was I_1 .

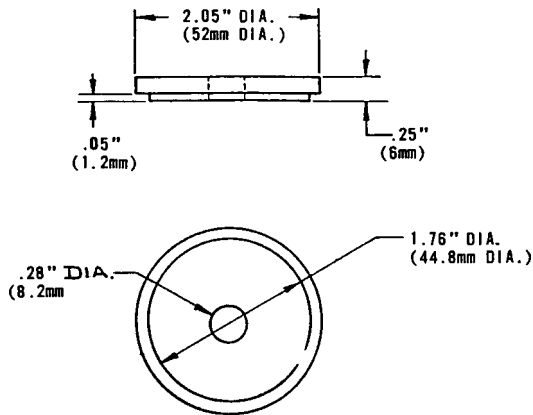

1 REQ'D NYLON

1 REQ'D BRASS

FIG. 6 Electrode Cap Detail

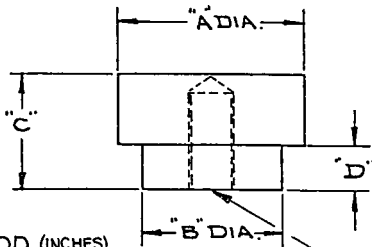

ROD (INCHES)					ROD (MM)				
DIA.	"A"	"B"	"C"	"D"	ROD DIA.	"A"	"B"	"C"	"D"
3/8	.385	.32	.39	.19	10	10	8	23	18
1/2	.510	.38	"	"	15	15	8	23	18
5/8	.635	.50	"	"					
3/4	.765	.50	"	"					

TUBE (INCHES)					TUBE (MM)				
DIA.	"A"	"B"	"C"	"D"	TUBE DIA.	"A"	"B"	"C"	"D"
1	1.02	.50	.39	.19	32	32	22	10	4.9
1 1/4	1.27	"	"	"	39	39	29	10	4.9
1 1/2	1.53	"	"	"	51	51	37	10	4.9
1 3/4	1.78	"	"	"	64	64	37	10	4.9
2	2.04	"	"	"	77	77	37	10	4.9
2 1/2	2.53	"	"	"					
3	3.04	"	"	"					

2 REQ'D EACH SIZE
BRASS

FIG. 7 Brass Electrode Detail

12.2.4.3 *Test Results*—The currents (I_1) measured shall be less than the values in Table 2. The difference between I_1 and I_2 shall be less than 20 μ A.

12.2.5 *Electrical Withstand Routine Tests*—Either Method 1 or Method 2 shall be used to perform the routine electrical withstand test for both FRP rods and FRP foam-filled tubes.

12.2.5.1 *Electrical Withstand Acceptance Test (Method 1) Without Dielectric Current Monitoring*—The typical test setup is shown in Fig. 10. Horizontally mount the test specimen at

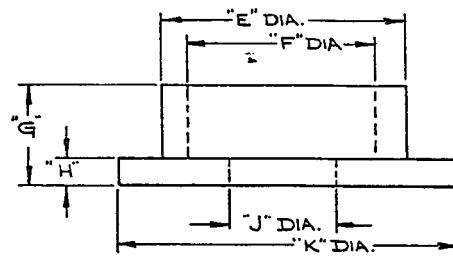

ROD (INCHES)							ROD (mm)						
DIA.	"E"	"F"	"G"	"H"	"J"	"K"	DIA.	"E"	"F"	"G"	"H"	"J"	"K"
3/8	.80	.41	.78	.20	.34	2.05	10	20	10.4	20	5	8.2	52
1/2	.90	.53	"	"	.40	"	15	25	15.4	20	5	8.2	52
5/8	1.10	.66	"	"	.52	"							
3/4	1.20	.79	"	"	.52	"							

TUBE (INCHES)							TUBE (mm)						
DIA.	"E"	"F"	"G"	"H"	"J"	"K"	DIA.	"E"	"F"	"G"	"H"	"J"	"K"
1	1.45	1.04	.78	.20	.52	2.05	32	42	32.2	20	5	22.2	52
1 1/4	1.70	1.29	"	"	"	"	39	49	39.2	20	5	29.2	52
1 1/2	1.95	1.55	"	"	"	"	51	61	51.2	20	5	37.2	61
1 3/4	2.20	1.80	"	"	"	"	64	74	64.2	20	5	37.2	74
2	2.45	2.06	"	"	"	2.45	77	87	77.2	20	5	37.2	87
2 1/2	2.95	2.55	"	"	"	2.95							
3	3.45	3.06	"	"	"	3.45							

2 REQ'D EACH SIZE
NYLON

FIG. 8 Nylon Electrode Support Detail

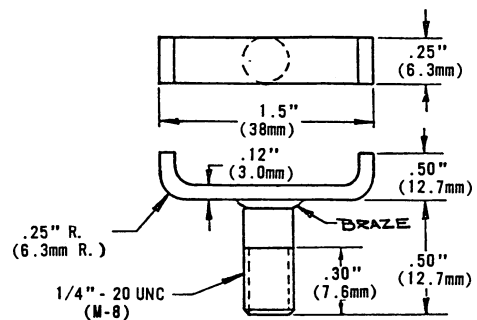

2 REQ'D BRASS

FIG. 9 Brass Screw Detail

least 3 ft (0.9 m) above the floor on an insulating support. The electrodes shall be spaced 12 in. apart.

(a) During the electrical withstand acceptance test, the tubes or rods shall be subjected to an alternating voltage of 100 kV rms at power frequency in accordance with Test Method D 149 at a maximum voltage rise of 3000 V/s. The test voltage shall be applied between electrodes for 5 min.

(b) During the course of the testing, there shall be no sign of flashover, puncture, tracking, or erosion on the surface of any sample. There shall be no perceptible temperature rise of any sample.

12.2.5.2 *Electrical Withstand Test (Method 2) With Dielectric Current Monitoring*—The typical test set-up is shown in

TABLE 2 Flexure Forces and Leakage Current ^A

TYPE	Outside Diameter		Flexure Forces		Leakage Current, <i>I</i> _l
	in.	(mm)	lbf	(N)	μA
Tube	1	(25.4)	220	(978.6)	5
	1¼	(31.8)	270	(1201.0)	6
	1½	(38.1)	370	(1645.8)	8
	1¾	(44.5)	550	(2446.5)	9
	2	(50.8)	670	(2980.3)	10
	2½	(63.5)	1680	(7473.0)	12
Rod	3	(76.2)	3030	(13 478.1)	14
	¾	(9.5)	50	(222.4)	6
	½	(12.7)	150	(667.2)	6
	¾	(15.9)	375	(1668.0)	6
	¾	(19.1)	800	(3058.6)	6

^A Values listed for maximum *I*_l are based on pole constructed of a relatively thin wall and filled internally with foam. Some special applications require a thicker wall, denser foam, or different materials, which could change the dielectric constant of the test setup and consequently *I*_l. Tubes such as these will still meet the requirements of this specification if the dry leakage is less than twice the listed maximum value of *I*_l in the table.

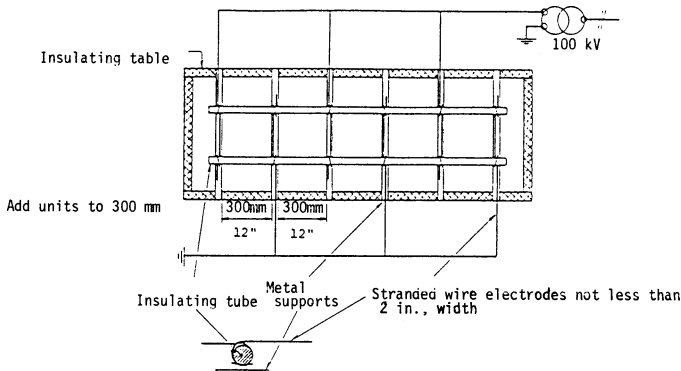

FIG. 10 Typical Test Arrangement for Electrical Withstand Acceptance Test

Figs. 11 and 12. The necessary equipment should be adequately shielded to provide accurate readings. The test fixture should be enclosed for worker protection and equipped with an

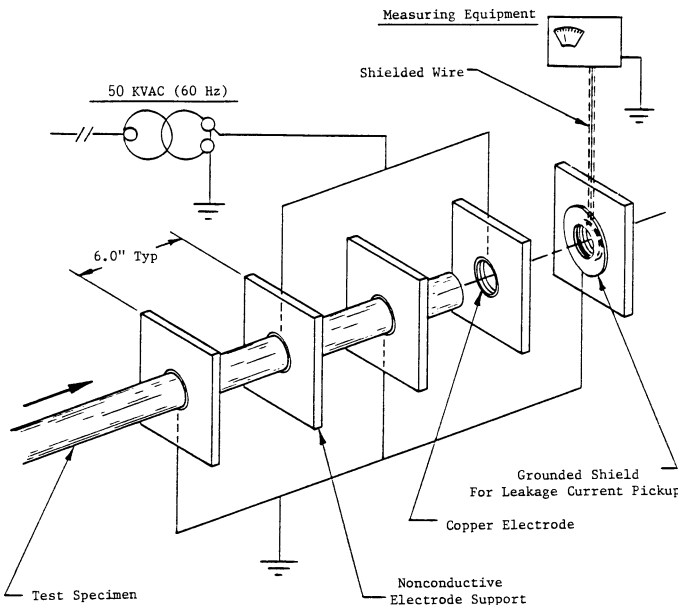

FIG. 11 Typical Test Set-Up

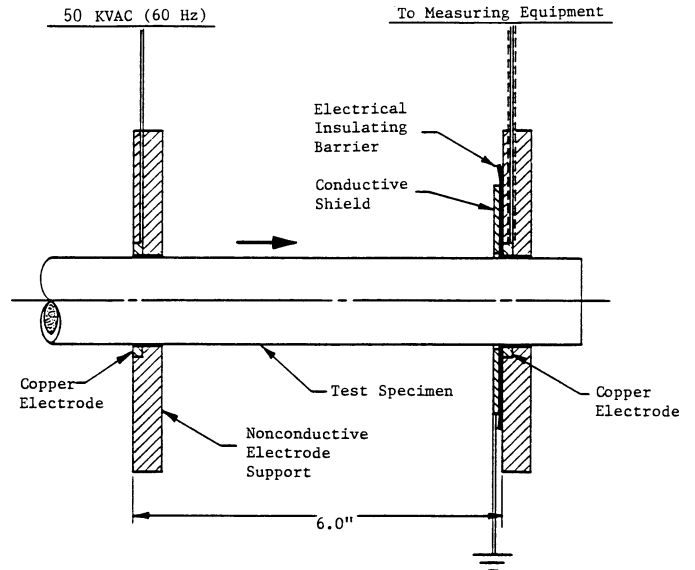

FIG. 12 Typical Test Set-Up

exhaust fan to provide a stable atmosphere. A motor drive should be utilized to ensure a uniform rate of feed. The feed rate should be proportional to the response time of the metering circuit; that is, it shall be run slowly enough that maximum readings are obtained. At no time should this rate of feed exceed 40 ft/min.

(a) With 6-in. electrode spacing, the applied voltage will be 50 kV. The equipment shall be designed such that a flashover, excessive dielectric current will disable the motor drive so that intentional action on the part of the operator is required to reset the equipment.

(b) Acceptable rise above ambient of less than *I*_l as listed in Table 2. During the course of the testing, there shall be no sign of flashover, puncture, tracking, or erosion on the surface of any sample.

12.3 Mechanical Testing of FRP Tube:

12.3.1 Bending Deflection Test (design)—A tube 8 ft 5 in. (2.6 m) or longer shall be placed in a testing device such that the overhang arm is 60 in. (1.5 m) in length, and the distance between supports is as shown in Fig. 13.

12.3.1.1 The support shall be of the pole clamp-type (approximately 4-in. (100-mm) long) with the back clamp tightened to hold specimen in place while the front clamp remains loose and serves only as a fulcrum. Both clamps shall be free to pivot as load (in Table 3) is applied 60 in. (1.5 m) from center of front clamping device (see Fig. 13).

12.3.1.2 The deflection of each tube tested shall not exceed the value specified in Table 3.

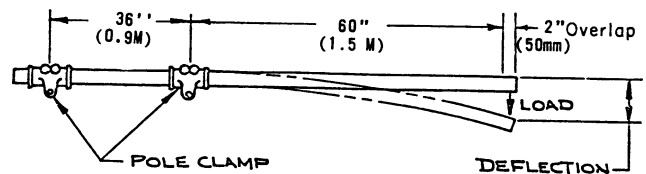

FIG. 13 Bending Deflection Test

TABLE 3 Deflection

Outside Diameter of Tube		Applied Force		Max Deflection	
in.	(mm)	lbf	(N)	in.	(mm)
1	(25.4)	20	(89.0)	20	(508.0)
1¼	(31.8)	50	(222.4)	20	(508.0)
1½	(38.1)	50	(222.4)	10	(254.0)
1¾	(44.5)	50	(222.4)	5.5	(139.7)
2	(50.8)	50	(222.4)	3.5	(88.9)
2½	(63.5)	50	(222.4)	1.75	(44.5)
3	(76.2)	150	(667.2)	2	(50.8)

12.3.2 *Horizontal Crush Test (design)*—The test specimens shall be 3 nominal diameters in length. Each specimen shall be tested separately. Each specimen shall be placed between smooth, flat, parallel, and rigid plates for the test (see Fig. 14). The length of the plates shall be at least equal to the specimen length plus ¾ in. (19 mm).

12.3.2.1 Reduce the distance between the two plates until a force, not greater than 20 lb, registers on the load instrumentation. Zero all instrumentation.

12.3.2.2 The distance between the two plates is then continuously decreased at a constant rate between 0.08 to 0.2 in. (2 to 5 mm)/min. Once selected this constant rate shall not be changed for that test.

NOTE 1—It is recognized that horizontal crush tests performed at a higher constant displacement rate are more severe.

12.3.2.3 Record the constant displacement rate selected. Record the maximum force applied to the test specimen during the first 0.25-in. (6-mm) displacement. All tubes shall be capable of exhibiting a crush strength equal to or in excess of minimum values listed in Table 4.

12.3.3 *Tension Test (design)*—The FRP tube shall exhibit axial tension strength equal to or in excess of the minimum values listed in Table 5. Cut the test specimens from the wall of a tube and accurately measure to permit cross section area calculations within 5 % of true value and in accordance with Test Method D 638 (see example in Fig. 1). The tensile strength of a tube is the product of the specimen ultimate load and the ratio of the area of the entire tube wall cross section to that of the test specimen. At the manufacturer’s option, the complete tube may be loaded to the tensile minimum of Table 5. When this option is chosen, the specimen length and holding means are optional with the manufacturer.

12.3.4 *Shear Test (design)*—FRP tube shall have a minimum average shear strength, parallel to the axis of the tube, as indicated in Table 6. Place the specimens between flat and parallel blocks for testing. Test two specimens from the same tube, with the shear planes radially separated by approximately 90°. Apply the testing force at a crosshead speed of 0.2 in. (5

TABLE 4 Crush Minimums

Diameter		Min Crush Strength	
in.	(mm)	lbf	(N)
1	(25)	650	(2891)
1¼	(32)	750	(3336)
1½	(39)	800	(3559)
1¾	(44)	850	(3781)
2	(51)	890	(3959)
2½	(64)	1210	(5382)
3	(76)	1500	(6672)

TABLE 5 Tensile Minimums for FRP Tubes

Diameter		Min Tensile Strength	
in.	(mm)	lbf	(N)
1	(25.4)	14 000	(62 275.1)
1¼	(31.8)	18 000	(80 068.0)
1½	(38.1)	29 000	(12 8998.4)
1¾	(44.5)	42 000	(18 6825.3)
2	(50.8)	43 000	(19 1273.5)
2½	(63.5)	64 000	(28 4686.2)
3	(76.2)	99 000	(44 0374.0)

TABLE 6 Average Shear Minimums for FRP Tubes

Diameter		Min Average Shear Strength	
in.	(mm)	lbf	(N)
1	(25.4)	590	(2624.5)
1¼	(31.8)	590	(2624.5)
1½	(38.1)	815	(3625.3)
1¾	(44.5)	1000	(4448.2)
2	(50.8)	890	(3958.9)
2½	(63.5)	1050	(4670.6)
3	(76.2)	1350	(6005.1)

mm)/per min. Record the maximum load at the point the sample shears (see example in Fig. 2).

12.4 *Mechanical Test of Solid Rod (design)*—The tensile strength of the rod in the direction of the fibers, when tested in accordance with Test Method D 638, shall be 80 000 psi (550 MPa) minimum. Compressive strength of the rod in the direction of the fibers, when tested in accordance with Test Method D 695, shall be 30 000 psi (205 MPa) minimum. The rod tensile modulus of elasticity when tested in accordance with Test Method D 638 shall be 1.5 × 10⁶ minimum.

12.5 *Mechanical Aging Test (design)*—Submit specimens of tubes and rods to cycles of simple flexure as described below. Each test is to be made on three specimens at environmental temperature of 60°F (16°C) minimum.

12.5.1 *Flexure*—Place a tube 8-ft (2.4-m) long or a rod 4-ft (1.2-m) long between two supports consisting of pulleys (see Fig. 15), the support points being separated as follows:

- 20 in. for solid rod
- 60 in. for 1 in., 1¼ in. tube
- 80 in. for 1½ in. tube and larger
- 0.5 m for solid rod
- 1.5 m for 32 mm tube
- 2.0 m for 39 mm tube and larger

12.5.1.1 At the center of the span, apply a vertical force to a fiber strap 2-in. (50-mm) wide, placed on the tube. The test consists of submitting each specimen to 1000 cycles of flexure in each quadrant by applying the force specified in Table 2.

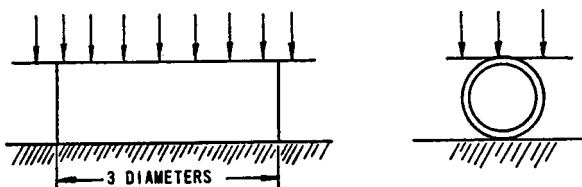
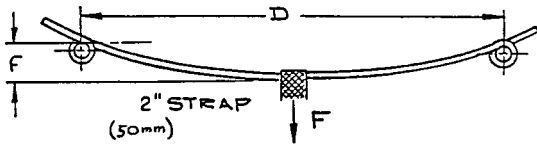
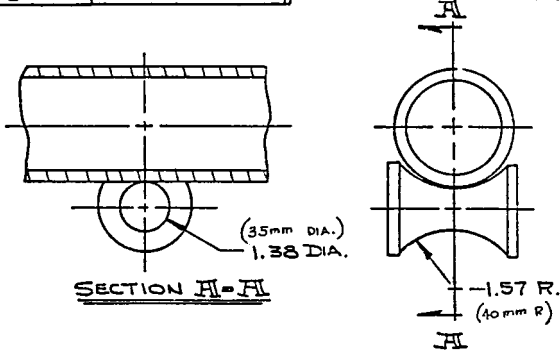

FIG. 14 Crush Test



INCHES		METRIC	
DIAMETER OF THE TUBE OR ROD	DISTANCE BETWEEN SUPPORTS "D"	DIAMETER OF ROD OR TUBE (mm)	DISTANCE BETWEEN SUPPORTS "D" - M.
3/8, 1/2, 5/8, 3/4	20	10-15	0.50
1, 1 1/4	60	32	1.50
1 1/2, 1 3/4, 2, 2 1/2, 3	80	39-51-64-77	2.00



DETAILS OF THE SUPPORTS

FIG. 15 Mechanical Tests

12.5.1.2 The flexure frequency during the test shall be between 1 and 5 cpm. After completion of the test, the tubes and rods shall reveal no visible signs of deterioration, bearing surfaces excluded.

12.5.2 *Wicking Test (design)*—Take three samples, each 1-in. (25-mm) long from midspan of mechanically aged tubes, and immerse them in Superior Viking Quick Drying Ink or equal with 50/50 ink/water solution to a minimum depth of 1/2 in. (12 mm). After 24 h in the ink solution, no wicking shall be observed at the free end of the 1-in. (25-mm) sample.

12.6 *Dimensional Check (Routine)*—Measure the diameters to verify conformity with the requirements of Table 1.

13. Rejection and Rehearing

13.1 Material that fails to conform to the requirements of this specification may be rejected. Rejection should be reported to the producer or supplier promptly and in writing. In case of dissatisfaction with the results of the test, the producer or supplier may request another test in the presence of his representative, and such a request should be granted.

14. Certification

14.1 Upon request of the purchaser in the contract or order, a manufacturer's certification that the material was manufactured and tested in accordance with this specification, together with a report of the test results, shall be furnished at the time of shipment.

15. Packaging, Marking, Shipping, and Preservation

15.1 Finished tubes and rods shall carry the following information affixed to the item in a manner that does not affect the performance:

- 15.1.1 Name of manufacturer,
- 15.1.2 Month and year of manufacture, and
- 15.1.3 That the product meets the requirements and bears the designated number of this specification.

SUPPLEMENTARY REQUIREMENTS

The following supplementary requirement shall apply only when specified in the purchaser order.

S1. Acceptance

S1.1 At the option of the purchaser, all or any part of an order of tubes or rods may be subjected to the following checks:

- S1.1.1 Visual check for general appearance, surface blemishes, air bubbles, or foreign bodies,
- S1.1.2 Dimensional checks,

S1.1.3 *Electrical Tests*—Tubes or rods selected shall withstand 100 kV at 60 Hz/12 in. (300 mm) for 5 min with a maximum rise of 3000 V/s or 50 kV at 60 Hz over a minimum length of 6 in. (150 mm), and

S1.1.4 *Mechanical Tests*—Tubes selected for mechanical tests shall be subjected to the bending deflection test and the loading forces as prescribed in 12.3.1. Deflection shall not exceed values specified in Table 3.

ASTM International takes no position respecting the validity of any patent rights asserted in connection with any item mentioned in this standard. Users of this standard are expressly advised that determination of the validity of any such patent rights, and the risk of infringement of such rights, are entirely their own responsibility.

This standard is subject to revision at any time by the responsible technical committee and must be reviewed every five years and if not revised, either reapproved or withdrawn. Your comments are invited either for revision of this standard or for additional standards and should be addressed to ASTM International Headquarters. Your comments will receive careful consideration at a meeting of the responsible technical committee, which you may attend. If you feel that your comments have not received a fair hearing you should make your views known to the ASTM Committee on Standards, at the address shown below.

This standard is copyrighted by ASTM International, 100 Barr Harbor Drive, PO Box C700, West Conshohocken, PA 19428-2959, United States. Individual reprints (single or multiple copies) of this standard may be obtained by contacting ASTM at the above address or at 610-832-9585 (phone), 610-832-9555 (fax), or service@astm.org (e-mail); or through the ASTM website (www.astm.org).