



Designation: F 855 – 97^{e1}

Standard Specifications for Temporary Protective Grounds to Be Used on De-energized Electric Power Lines and Equipment¹

This standard is issued under the fixed designation F 855; the number immediately following the designation indicates the year of original adoption or, in the case of revision, the year of last revision. A number in parentheses indicates the year of last reapproval. A superscript epsilon (ϵ) indicates an editorial change since the last revision or reapproval.

^{e1} NOTE—Editorial changes were made in February 2000.

1. Scope

1.1 These specifications cover the equipment making up the temporary grounding system used on de-energized electric power lines, electric supply stations, and equipment.

1.2 It is common practice for the users of protective grounding equipment to prepare complete instructions and regulations to govern in detail the correct use and maintenance of such equipment.

1.3 The uses and maintenance of this equipment are beyond the scope of these specifications.

1.4 These specifications for a system of protective grounding utilizing copper cables are covered in four parts, as follows:

	Sections
Clamps for Temporary Protective Grounds	4-16
Ferrules for Temporary Protective Grounds	17-30
Cables for Temporary Protective Grounds	31-39
Protective Grounds (Complete Assembly With Clamps, Ferrules, and Cable)	40-52

1.5 Each of the four parts is an entity of itself, but is listed as a part of the system for completeness and clarification.

1.6 The values stated in Newton-Meter units are to be regarded as the standard. The values in parentheses are the inch-pound units.

1.7 Currents presented in Table 1 and Table 2 are based upon cable melting times, as determined from equations by I. M. Onderdonk. See Appendix X3.

1.7.1 Currents presented in Table 3 were determined by use of EPRI Project RP2446 Computer Program RTGC “A Desktop Computer Program for Calculating Rating of Temporary Grounding Cables”.

1.7.2 See Appendix X3 and Appendix X4 for a discussion of these values.

1.8 The following precautionary caveat pertains to the test method portions, Sections 12 and 25 of these specifications: *This standard does not purport to address all of the safety*

concerns, if any, associated with its use. It is the responsibility of the user of this standard to establish appropriate safety and health practices and determine the applicability of regulatory limitations prior to use.

2. Referenced Documents

2.1 ASTM Standards:

B 172 Specification for Rope-Lay-Stranded Copper Conductors Having Bunch-Stranded Members, for Electrical Conductors²

B 173 Specification for Rope-Lay-Stranded Copper Conductors Having Concentric-Stranded Members, for Electrical Conductors²

B 263 Test Method for Determination of Cross-Sectional Area of Stranded Conductors²

D 470 Test Methods for Cross-linked Insulations and Jackets for Wire and Cable³

D 753 Specification for General-Purpose Polychloroprene Jacket for Wire and Cable³

D 2219 Specification for Poly(Vinyl Chloride) Insulation for Wire and Cable, 60 Operation³

D 2633 Methods of Testing Thermoplastic Insulations and Jackets for Wire and Cable³

D 2768 Specification for General-Purpose Ethylene Propylene Rubber Jacket for Wire and Cable³

D 2770 Specification for Ozone-Resisting Ethylene Propylene Rubber Integral Insulation and Jacket for Wire and Cable³

E 8 Test Methods of Tension Testing of Metallic Materials⁴

E 380 Practice for Use of the International System of Units (SI) (the Modernized Metric System)⁵

2.2 ANSI Standard:

C 37.09 Standard Test Procedure for AC High-Voltage Circuit Breakers Rated on a Symmetrical Basis⁶

2.3 ICEA/NEMA Standard:

² Annual Book of ASTM Standards, Vol 02.03.

³ Annual Book of ASTM Standards, Vol 10.01.

⁴ Annual Book of ASTM Standards, Vol 03.01.

⁵ Annual Book of ASTM Standards, Vol 14.02.

⁶ Available from American National Standards Institute, 11 West 42nd St., 13th Floor, New York, NY 10036.

¹ These specifications are under the jurisdiction of ASTM Committee F-18 on Electrical Protective Equipment for Workers and are the direct responsibility of Subcommittee F18.45 on Mechanical Apparatus.

Current edition approved Dec. 10, 1997. Published February 1999. Originally published as F 855 – 83. Last previous edition F 855 – 96.



TABLE 1 Protective Ground Clamp Ratings

Grade	Grounding Clamp Torque Strength, min				Short Circuit Properties ^A								Continuous Current Rating, A RMS, 60 Hz	Minimum Cable Size with Ferrule Installed Equal or Larger Than
	Yield ^B		Ultimate		Withstand Rating, Symmetrical kA RMS, 60 Hz				Ultimate Rating/Capacity, ^{CD} Symmetrical kA RMS, 60 Hz					
					15 cycles (250 ms)	30 cycles (500 ms)	Copper Cable Size	6 cycles (100 ms)	15 cycles (250 ms)	30 cycles (500 ms)	60 cycles (1 s)	Maximum Copper Test Cable Size		
	lbf-in.	n-m	lbf-in.	n-m										
1	280	32	330	37	14	10	#2	29	18	13	9	2/0	200	#2
2	280	32	330	37	21	15	1/0	47	29	21	14	4/0	250	1/0
3	280	32	330	37	27	20	2/0	58	37	26	18	4/0	300	2/0
4	330	37	400	45	34	25	3/0	74	47	33	23	250 kcmil	350	3/0
5	330	37	400	45	43	30	4/0	94	59	42	29	250 kcmil	400	4/0
6	330	37	400	45	54	39	250 kcmil or 2 2/0	111	70	49	35	350 kcmil	450	250 kcmil or 2 2/0
7	330	37	400	45	74	54	350 kcmil or 2 4/0	155	98	69	48	550 kcmil	550	350 kcmil or 2 4/0

^A Withstand and ultimate short circuit properties are based on performance with surges not exceeding 20 % asymmetry factor (see 9.1 and 12.3.4.2).

^B Yield shall mean no permanent deformation such that the clamp cannot be reused throughout its entire range of application.

^C Ultimate rating represents a symmetrical current which the clamp shall carry for the specified time.

^D Ultimate values are based upon application of Onderdonk's equation to 98 % of nominal circular mil area allowed by Specifications B 172 and B 173.

TABLE 2 Protective Ground Cable Ferrule, and Assembly Ratings

Grade	Cable Size	Short Circuit Properties ^A —Symmetrical kA RMS 60 Hz						Continuous Current Rating, RMS 60 Hz
		Withstand Rating			Ultimate Rating/Capacity ^{B,C}			
		15 cycles (250 ms)	30 cycles (500 ms)	6 cycles (100 ms)	15 cycles (250 ms)	30 cycles (500 ms)	60 cycles (1 s)	
1	2	14	10	28	18	13	9	200
2	1/0	21	15	47	29	21	14	250
3	2/0	27	20	59	37	26	18	300
4	3/0	34	25	74	47	33	23	350
5	4/0	43	30	94	59	42	29	400
6	250 kcmil	54	39	111	70	49	35	450
7	350 kcmil	74	54	155	98	69	49	550

^A Withstand and ultimate short circuit properties are based on performance with surges not exceeding 20 % asymmetry factor (see 9.1 and 12.3.4.2).

^B Ultimate rating represents a symmetrical current which the ferrule shall carry for the time specified.

^C Ultimate value based upon application of Onderdonk's equation to 98 % of nominal circular mil area allowed by Specifications B 172 and B 173.

ICEA S-19-81/NEMA WC 80 (R 1986) Rubber Insulated Wire and Cable for the Transmission and Distribution of Electrical Energy ⁷

2.4 IEC Standard:

IEC 1230 Portable Equipment for Earthing or Earthing and Short-Circuiting (currently under review) ⁸

3. Terminology

3.1 Definitions of Terms Specific to This Standard:

3.1.1 *continuous current rating*—designated RMS current which can be carried continuously under specified conditions.

3.1.2 *protective ground assembly*—a temporary electrical connection between a source of potential energization and the earth, rated for the maximum anticipated fault current or continuous induced current, or both.

3.1.2.1 *Discussion*—Throughout this specification, kcmil = 1000 circular mils.

3.1.3 *protective grounding equipment*—devices installed temporarily on de-energized electric power circuits for the

purposes of potential equalization and to conduct a short circuit current for a specified duration (time).

3.1.4 *time to failure*—failure time of the cable is the time between the initiation of current flow and the instant at which arcing begins.

3.1.5 *ultimate capacity*—this represents a current which it is calculated the component is capable of conducting for the specified time. It is expected that component damage may result. The component shall not be reused, except in test situations.

3.1.6 *withstand rating*—this represents a near symmetrical current which shall be conducted without any component being damaged sufficiently to prevent being operable and reusable. The protective ground shall be capable of passing a second test at this current after being cooled to ambient temperature.

CLAMPS FOR TEMPORARY PROTECTIVE GROUNDS

4. Scope

4.1 This specification covers clamps used with ferrules and elastomer or thermoplastic covered flexible cable in the manufacture of protective grounds installed temporarily for protective grounding of de-energized circuits.

⁷ Available from Insulated Cable Engineers Assoc., P.O. Box P, South Yarmouth, MA 02664.

⁸ Available from IEC.



TABLE 3 Ultimate Current Carrying Capabilities of Copper Grounding Cable Derived from EPRI RP2446

TABLE 3a Worst Case: X/R = 40; DC Offset = 92 %, Kiloamperes, Asymmetrical, RMS, 60 Hz

Copper Grounding Cable Size, AWG	Nominal Cross Section, mm ²	6 Cycles (100 ms)	15 Cycles (250 ms)	30 Cycles (500 ms)	45 Cycles (750 ms)	60 Cycles (1 s)	Continuous Current Rating, RMS, 60 Hz
#2	33.63	23	17	13	11	9	200
1/0	53.48	36	26	20	17	15	250
2/0	67.42	46	33	26	21	19	300
3/0	85.03	57	42	32	27	24	350
4/0	107.2	72	53	41	34	30	400
250 kcmil	126.65	86	63	48	40	35	450
350 kcmil	177.36	120	88	67	56	50	550

Table 3b Midrange: X/R = 10; DC Offset = 74 %, Kiloamperes, Asymmetrical, RMS, 60 Hz

Copper Grounding Cable Size, AWG	Nominal Cross Section, mm ²	6 Cycles (100 ms)	15 Cycles (250 ms)	30 Cycles (500 ms)	45 Cycles (750 ms)	60 Cycles (1 s)	Continuous Current Rating, RMS, 60 Hz
#2	33.63	28	19	14	11	10	200
1/0	53.48	44	30	22	18	16	250
2/0	67.42	57	38	27	23	20	300
3/0	85.03	71	48	35	28	25	350
4/0	107.2	89	60	44	36	31	400
250 kcmil	126.65	105	71	51	42	37	450
350 kcmil	177.36	147	100	72	59	52	550

Table 3c Best Case: X/R = 0; DC Offset = 0 %, Kiloamperes, Asymmetrical, RMS, 60 Hz

Copper Grounding Cable Size, AWG	Nominal Cross Section, mm ²	6 Cycles (100 ms)	15 Cycles (250 ms)	30 Cycles (500 ms)	45 Cycles (750 ms)	60 Cycles (1 s)	Continuous Current Rating, RMS, 60 Hz
#2	33.63	31	20	14	11	10	200
1/0	53.48	50	32	22	18	16	250
2/0	67.42	63	40	28	23	20	300
3/0	85.03	79	50	35	29	25	350
4/0	107.2	100	63	45	36	32	400
250 kcmil	126.65	118	75	53	43	37	450
350 kcmil	177.36	165	104	74	60	52	550

5. Classification

5.1 Clamps are furnished in, but not limited to, three types according to their function and method of installation, as follows:

5.1.1 *Type I*—Clamps for installation on de-energized conductors equipped with eyes for installation with removable hot sticks.

5.1.2 *Type II*—Clamps for installation on de-energized conductors having permanently mounted hot sticks.

5.1.3 *Type III*—Clamps for installation on permanently grounded conductors or metal structures with tee handles, and eyes or square or hexagon head screw(s), or both.

5.1.4 Other types of special clamps, such as those for cluster grounds or for underground equipment grounding, may be made, tested, and certified by the manufacturer as meeting the requirements of this specification.

5.2 Clamps are furnished in grades according to mechanical strengths, short circuit capabilities, and duration of faults, as indicated in Table 1.

5.3 Clamps are furnished in two classes according to the characteristics of the main contact jaws:

5.3.1 *Class A*—Clamp jaws with smooth contact surfaces.

5.3.2 *Class B*—Clamp jaws with serrations, or cross hatching, or other means intended to abrade or bite through corrosion products on the surfaces of the conductor being clamped.

6. Sizes

6.1 Clamp size is the combination of the main contact and cable size ranges as listed by the manufacturers. It should be noted that the main contact may connect to a cable or bus bar or be used at the “ground end” to connect to a variety of conductive grounded objects.

7. Ordering Information

7.1 Orders for clamps under this specification shall include this ASTM designation and the following information:

7.1.1 Quantity,

7.1.2 Name (grounding clamp),

7.1.3 Main contact size ranges, conductor descriptions, and materials which are to be clamped by main contact,

7.1.4 Cable size, material, and description by which clamps are to be assembled,

7.1.5 Type (see 5.1),

7.1.6 Grade (see 5.2 and Table 1),

7.1.7 Class (see 5.3), and

7.1.8 Asymmetrical current or other supplementary requirements, if applicable. (See Supplementary Requirements S1 to S10 for styles and designs.)

NOTE 1—A typical ordering description is as follows: 100 Grounding Clamps, Main contact range #2 to 350 kcmil for 2/0 Copper flexible grounding cable, ASTM F855, Type 1, Grade 2, Class A, Design C, Style 7, or X/R maximum, in addition to the grade designation.

NOTE 2—It is expected that manufacturers will publish catalog data



conforming to this specification that will combine the requirements of 7.1.2-7.1.8 in a single product number. With that system, a typical order description is: 100 (Smith Manufacturing Co. Product No. XXXX) grounding clamps ASTM F855, Grade 2.

8. Materials

8.1 Current carrying parts made of copper base or aluminum base alloy shall have the following material properties in accordance with Test Methods E 8:

	Copper Base Alloy	Aluminum Base Alloy
Tensile strength, min	207 MPa (30 000 psi)	207 MPa (30 000 psi)
Yield strength, min	90 MPa (13 000 psi)	138 MPa (20 000 psi)
Elongation, min	6 %	3 %

8.2 Type II clamps shall be equipped with an insulating handle (hot stick) appropriate for the nominal voltage of the circuit to be grounded.

9. Electrical and Mechanical Properties

9.1 Electrical and mechanical properties shall conform to the requirements prescribed in Table 1 or Table 3, as appropriate, and the following paragraphs. See Appendix X3 for a discussion and derivation of the current levels. See Appendix X4 for a discussion of the effects of asymmetrical current.

9.1.1 Types I and II stick installed clamps shall be designed such that a failure does not increase the risk of injury to the user or have excess mechanical strength to prevent failure, defined as follows:

9.1.1.1 In the event the clamp is over-torqued during installation, normal fracture shall be such that the attached cable remains under control by being retained with the stick.

9.1.1.2 Clamps with an ultimate torque strength exceeding 45 N·m (400 lbf-in.) are exempt from the provisions of 9.1.1.1.

9.1.2 Resistance from the main contact to the attached cable contact shall be less than that for an equal length of maximum size cable(s) for which the clamp is rated.

9.1.3 Main contacts shall accept and clamp all conductors or structural members in accordance with the manufacturer’s rating.

9.1.4 Clamp shall accept hand assembly of all cables fitted with compatible ferrules as rated by the manufacturer (see Table 2 and Table 4).

9.1.5 Cable termination shall include a cable support or shall be made to accept a cable supporting ferrule, available from the same manufacturer. This support shall secure the entire cable over the jacket and is provided in addition to the electrical connection to the strand.

9.1.6 Type I clamps shall be operable with clamp sticks and shall fit securely inside a nominal 13 mm (½ in.) wide slot in the head of the stick.

10. Workmanship, Finish, and Appearance

10.1 Components shall be free of structural porosity, fins, sharp edges, splits, cracks, and other defects that affect handling or performance.

10.2 All parts shall be formed, machined, and assembled with sufficient accuracy for smooth operation by hand, and shall be free of excessive looseness to the extent detrimental to repeated applications at the recommended installing torque.

TABLE 4 Cable Terminations and Compatible Ferrules for Protective Ground Clamps

Grounding Clamp			Matching Cable Ferrule		
ASTM Cable Termination Style	Cable Termination Description	Essential Size Data	ASTM Ferrule Type	Ferrule Description	Essential Data ^A
					Size
1	Cable retaining eyebolt	ferrule OD accepted Stud and shroud OD accepted	I	compression	compressed OD
			III	plain stud shrouded compression	stud dia and compressed shroud dia
2	eyebolt and cable support	ferrule or stud dia accepted	I	compression	compressed OD
3	plain bore bolted clamp and cable support		III	plain stud shrouded compression	stud dia and compressed shroud dia
4	plain bore tubular with screws and cable support				
5	plain bore boss	nominal ID ½ in. (12.7 mm), ⅝ in. (16 mm), or ¾ in. (20 mm) and included angle of cone contact	IV	threaded stud shrouded	stud or bolt dia ^B ½ in.-13NC, ⅝ in.-11 NC, or ¾ in.-10 NC and included angle of cone contact
6	plain bore boss and cable support		V	compression	stud size ^B ½ in.-13 NC, ⅝ in.-11 NC, or ¾ in.-10 NC
			IV	bolted shrouded compression	
			V	compression	
			V	threaded stud shrouded compression	
7	threaded bore boss	thread size ^B ½ in.-13 NC, ⅝ in.-11 NC, or ¾ in.-10 NC	VI	threaded stud shrouded	stud size ^B ½ in.-13 NC, ⅝ in.-11 NC, or ¾ in.-10 NC
IV			compression		
VI			threaded stud compression		
8	threaded bore boss and cable support				
9	threaded bore clamp and cable support			ferrule	

^A The material shall be copper or aluminum base. The cable size and material description shall include overall outside diameter.

^B Bolt stud and thread sizes metric conversion is as follows: 1 / 2 in.-13 NC = M12 × 1.75, 5 / 8 in.-11 NC = M16 × 2.00, 3 / 4 in.-10 NC = M20 × 2.50

10.3 Class A (smooth jaw) clamps shall have smooth contact surfaces free of burrs, fins, or other protuberances that would impair performance.

10.4 Class B (serrated jaw) clamps shall have longitudinally level surfaces that, with clamp movement as specified by the manufacturer, will provide a cleaning effect on the surface of the conductor.

10.5 Snag grinding marks, depressions, and other surface irregularities which do not affect strength, performance, or handling are not cause for rejection.

11. Sampling

11.1 A product model represents a manufacturer's design specification standard according to which the production lot is manufactured.

11.2 A production lot shall consist of all clamps of one product model produced at one time.

11.3 A test sample shall consist of two specimens for each different test specified. Specimens are selected at random and shall pass the inspection requirements of Section 13. When a failure occurs in one specimen from the first sample, a second sample from the same lot shall be selected and tested. If the second sample (two specimens) passes, the lot shall be accepted. If one specimen from the second sample fails, the lot shall be rejected.

12. Design Tests

12.1 The design tests that follow shall be made on test samples of each product model to verify that the requirements of this specification are met.

12.2 Mechanical Torque Strength:

12.2.1 Install the clamp on the main conductor of the minimum and maximum size for which the clamp is rated and apply torsional force to the main screw. Force may be applied to other devices designed to secure the clamp on the conductor.

12.2.2 Measure torque by a torque wrench that indicates torque directly or by another manner easily convertible.

12.2.3 The main conductor is defined as the material(s) for which the clamp is rated to be used.

12.2.4 Yield and ultimate strength shall equal or exceed the values shown in Table 1.

12.3 Electrical Short Circuit Capacity:

12.3.1 Assemble the clamp with ferrules and cable in accordance with the manufacturer's specifications. The current is to be determined by the method described in ANSI C37.09-1979 (R-1989, Section 7).

12.3.2 Electrode spacing shall be as specified in Fig. 1, with the clamps in a vertical position, in order that the slack cable length stresses the clamps with electromagnetic tensile impact during test surge.

12.3.3 Test the clamp on the main conductor within the rated range established by manufacturer.

12.3.4 Short circuit values and time durations specified by the customer shall be as specified in Table 1 or Table 3, as appropriate. Table 1 shall be used if no asymmetrical currents have been specified.

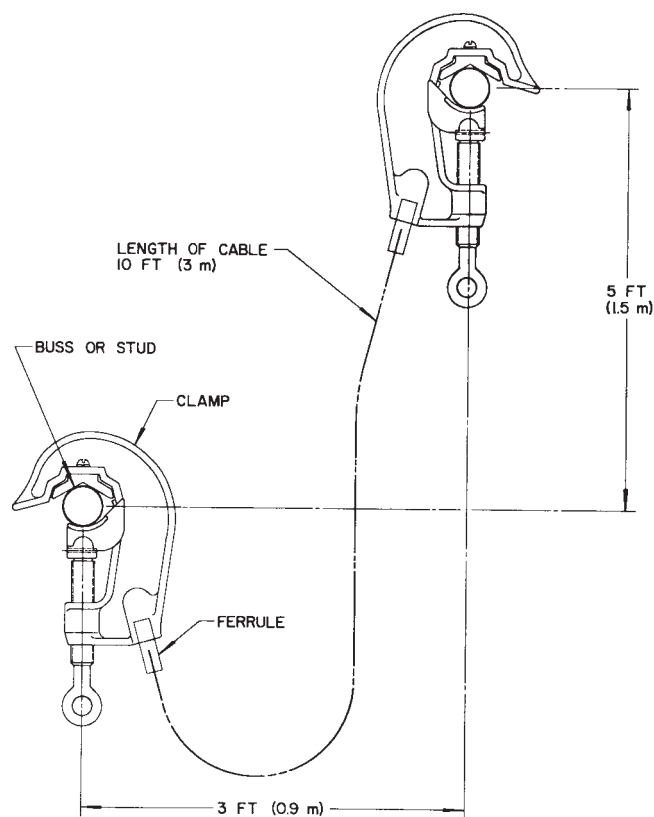

FIG. 1 Fixture for Testing Ground Clamps, Ferrules, Cables, and Jumpers

12.3.4.1 The withstand rating of Table 1 represents a near symmetrical current which the clamp shall conduct without being damaged sufficiently to prevent being operable and reusable.

12.3.4.2 The ultimate rating of Table 1 represents a current which the clamp shall carry for the specified time. Table 3 represents an ultimate current, at a specified X/R ratio. The clamp thus tested might be damaged and shall not be reused.

12.4 Grounding, clamps and ferrules tested at their continuous current rating shall have a lower maximum temperature than that of the maximum size copper main or tap cable for which rated. Temperature shall be measured at the warmest spot on the clamp, midpoint on the ferrule and on the metal strand at the midpoint of the main and top conductors, each a minimum of 1.5 m (5 ft).

13. Inspection and Product Testing

13.1 The clamps shall be inspected and tested as follows:

13.1.1 Verification of the main contact and cable capacities shall be in accordance with 9.1.2 and 9.1.3.

13.1.2 Visual inspection and hand operation to verify workmanship, finish, and appearance shall be in accordance with Section 10.

13.1.3 Torque test on a test sample shall be in accordance with 12.2.

14. Acceptance, Rejection, and Rehearing

14.1 At the option of the purchaser, a production lot may be subjected to the following:

CABLE FERRULES FOR TEMPORARY PROTECTIVE GROUNDS

14.1.1 Inspection in accordance with 13.1 for operation, main contact range, workmanship, and appearance. Individual clamps that do not conform may be rejected.

14.1.2 Resistance comparison test in accordance with 9.1.2.

14.2 Material that fails to conform to the requirements of this specification may be rejected. Rejection should be reported to the producer or supplier promptly and in writing. In case of dissatisfaction with the results of the test, the producer or supplier may make claim for a rehearing.

14.3 If electrical, or mechanical testing, or both, are required by a user prior to acceptance, or for in-service testing, minimum testing shall be done in accordance with this specification for any part or for all of the tests to be performed.

15. Certification

15.1 When specified in the purchase order or contract, a manufacturer's or supplier's certification shall be furnished to the purchaser that the clamps were manufactured, sampled, tested, and inspected in accordance with this specification and found to meet the requirements. When specified in the purchase order or contract, a report of design test, or surge test oscillogram, or both, shall be furnished.

16. Packaging and Package Marking

16.1 Clamps shall be marked with the name or logo of the manufacturer, identity number, and date code to indicate year of manufacture.

16.2 A packing list indicating manufacturer's product numbers and quantities of each different clamp shall be provided with each shipment.

16.3 Each shipment shall be packaged to provide protection of the contents appropriate for the mode of transportation.

17. Scope

17.1 This specification covers ferrules used with cables, clamps, and connectors in the manufacture of protective grounds, installed temporarily for protective grounding of de-energized circuits.

18. Classification

18.1 Ferrules are furnished in five types as shown in Table 5 and Table 6, and are as follows:

18.1.1 *Type I*—Compression ferrule is cylindrical and made for installation on cable stranding by compression.

18.1.2 *Type III*—Plain stud-shrouded compression ferrule has a stepped bore that accepts entire cable over jacket.

18.1.3 *Type IV*—Threaded stud shrouded compression ferrule has a stepped bore that accepts entire cable over jacket and has male threads at forward end.

18.1.4 *Type V*—Bolted shrouded compression ferrule has internal threads and a bolt at forward end.

18.1.5 *Type VI*—Threaded stud compression ferrule has male threads at forward end.



18.2 Ferrules are furnished in grades in accordance with cable capacity, short circuit capabilities, and duration of faults as indicated in Table 2.

19. Size

19.1 Ferrule size is the combination of cable capacity, stud description, and size after installation of cable (see Table 4 for standard sizes according to types and minimum grade requirements).

TABLE 5 Protective Ground Cable Ferrule Physical Specifications

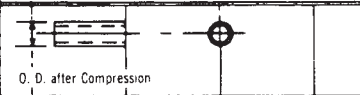
Note—Inspection or vent holes are optional for Types III, IV, V, and VI.

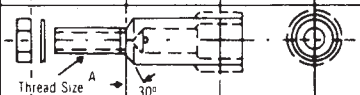
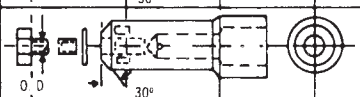
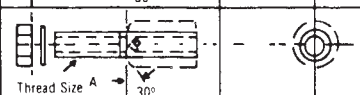
Type	Description	Shape	Minimum Specifications to be Supplied by Manufacturers in Addition to Cable Capacity and Material
I	Compression		Installing Die Code O. D. after Installation
III	Plain Stud Shrouded Compression		Installing Die Codes Stud O. D.
IV	Threaded Stud Shrouded Compression		Installing Die Codes Thread Size A
V	Bolted Shrouded Compression		Installing Die Codes Bolt O. D. or Thread Size
VI	Threaded Compression		Installing Die Codes Thread Size A

^A Standard thread sizes are as follows: 1/2in.-13 UNC = M12 × 1.75, 5/8in.-11 UNC = M16 × 2.00, [frac;3;4] in.-10 UNC = M20 × 2.50.

TABLE 6 Protective Ground Cable Ferrule and Compatible Clamp Terminations

Note—Inspection or vent holes are optional for Types III, IV, V, and VI.

CABLE FERRULES ASTM			MATCHING GRUNDING CLAMP CABLE TERMINATION ASTM		
ASTM Ferrule Type	Ferrule Description	Illustration of Ferrule Including Essential Interface Application Data Required	ASTM Termination Style	Termination Description	Essential Interface Application Data Required
I	Compression Ferrule		1.	Cable Retaining Eyebolt	Ferrule or Stud O. D. Accepted
			2.	Eyebolt & Cable Support	
			3.	Plain Bore Clamp and Cable Support	
III	Plain Stud Shrouded Compression Ferrule		4.	Plain Bore Tubular With Screws and Cable Support	
IV	Threaded Stud Shrouded Compression Ferrule		5.	Plain Bore Boss	Tap Boss I. D. or Thread Size ^A and Material
			6.	Plain Bore Boss and Cable Support	
			7.	Threaded Bore Boss	
V	Bolted Shrouded Compression Ferrule		5.	Plain Bore Boss	Tap Boss I. D. and Material
			6.	Plain Bore Boss and Cable Support	
VI	Threaded Compression Ferrule		6.	Plain Bore Boss and Cable Support	Tap Boss Thread Size ^A and Material
			8.	Threaded Bore Boss and Cable Support	
			9.	Threaded Bore Clamp and Cable Support	

^AStandard thread sizes are as follows: 1/2 in.—13 UNC = M12 × 1.75, 5/8 in.—11 UNC = M16 × 2.00, [frac;3;4] in.—10 UNC = M20 × 2.50.

20. Ordering Information

20.1 Orders for ferrules under this specification should include this ASTM designation and the following information:

- 20.1.1 Quantity,
- 20.1.2 Unit of measure (each or pair),
- 20.1.3 Name (grounding cable ferrules),
- 20.1.4 Tap contact size, description, and material of clamp or connector in which ferrule is to be installed,
- 20.1.5 Cable description, to include strand size, material, and outside diameter on which ferrule is to be installed,
- 20.1.6 Type (see 18.1),
- 20.1.7 Grade (see 18.2 and Table 2), and
- 20.1.8 Asymmetrical current or other supplementary requirements, if applicable (see Supplementary Requirements S1 to S17).

NOTE 3—A typical ordering description is as follows: 100 Pairs Grounding Cable Ferrules, for tap contact 5/8-11 NC aluminum clamp and grounding cable 4/0-2019 W CU 21 mm (0.83 in.) O.D., ASTM F855, Type IV, Grade 4, or X/R maximum, in addition to the grade designation.

NOTE 4—It is expected that manufacturers will publish catalog data conforming to this specification which will combine the requirements of 20.1.2-20.1.8 in a single product number. With that system, a typical order description is as follows: 100 (Smith Manufacturing Co. Product No. XXXX) grounding cable ferrules, ASTM F855, Grade 4.

21. Materials

21.1 Current carrying parts of copper base or aluminum base ferrules shall meet the following requirements:

- 21.1.1 *Copper Base Alloy*—Copper content 60 % minimum.
- 21.1.2 *Aluminum Base Alloy*—Aluminum content 90 % minimum.

22. Electrical and Physical Properties

22.1 Closed end ferrules utilizing the compression method for cable installation may have a 3 mm (0.125 in.) minimum diameter inspection vent hole through one side at the bottom of the (cable) bore. This applies to Types III, IV, V, and VI.

22.2 Ferrules shall accept cables for which they are rated without alteration of strands, and can be assembled by hand with compatible clamps.

22.3 Table 2 and Table 3 specify current levels. See Appendix X3 for a discussion and the derivation of these current levels. See Appendix X4 for a discussion of the effects of asymmetrical current.

23. Workmanship, Finish, and Appearance

23.1 Components shall be free of structural defects that affect installation, assembly, or performance.

23.2 Minor surface irregularities that do not affect strength or performance are not cause for rejection.

24. Sampling

24.1 A product model represents a manufacturer’s design specification according to which the production lot is manufactured.

24.2 A production lot shall consist of all ferrules of one product model produced at one time.

24.3 A test sample shall consist of two specimens selected at random from a production lot for each different test specified. When a failure occurs in one specimen from the first sample, a second sample shall be selected from the same lot and tested.



If the second sample (two specimens) passes, the lot shall be acceptable. If one specimen from the second sample fails, the lot shall be rejected.

25. Design Tests

25.1 Design tests shall be made on test samples of each product model to verify that the requirements of the specification are met.

25.2 *Electrical Short-Circuit Capacity:*

25.2.1 Install the ferrules in accordance with specifications on maximum capacity grounding cable and clamps which have been rated. The current is to be determined by the method described in ANSI C37.09, Section 7. Cables shall have a minimum length of 3 m (10 ft).

25.2.2 Cable configuration and electrode spacing shall be as specified in Fig. 1, with the clamps in the vertical position, in order that the slack cable length stresses the ferrules with electromagnetic tensile impact during test surge.

25.2.3 Short circuit values and time durations specified by the customer shall be as specified in Table 2 or Table 3, as appropriate. Table 2 shall be used if no asymmetrical currents have been specified.

25.2.3.1 The withstand rating of Table 2 represents a current which ferrules shall conduct without being damaged sufficiently to prevent being operable and reusable.

25.2.3.2 The ultimate rating of Table 2 represents a symmetrical current which the ferrule shall carry for the specified time. Table 3 represents an ultimate current at a specified *X/R* ratio. The ferrule thus tested might be damaged and shall not be reused except for test purposes.

25.3 *Continuous Current Rating*—Grounding, clamps and ferrules tested at their continuous current rating shall have a lower maximum temperature than that of the maximum size copper main or tap cable for which rated. Temperature shall be measured at the warmest spot on the clamp, midpoint on the ferrule and on the metal strand at the midpoint of the main and top conductors, each a minimum of 1.5 m (5 ft).

26. Inspection

26.1 Visual and gaging inspection shall verify workmanship, finish, and appearance in accordance with Section 23.

27. Acceptance, Rejection, and Rehearing

27.1 At the option of the purchaser, a production lot may be subjected to the following:

27.1.1 Gaging inspection in accordance with Section 26. Individual ferrules that do not conform may be rejected.

27.1.2 A test sample may be tested for continuous current, or surge, or both, in accordance with Table 2 or Table 3, as appropriate.

27.1.3 Failure of two specimens from two test samples which have been properly installed in accordance with the manufacturer's specifications shall be cause for rejection of the production lot from which the samples were taken.

27.1.4 Material that fails to conform to the requirements of this specification may be rejected. Rejection should be reported to the producer or supplier promptly and in writing. In case of dissatisfaction with the results of the test, the producer or supplier may make claim for a rehearing.

28. Certification

28.1 When specified in the purchase order or contract, a producer's or supplier's certification shall be furnished to the purchaser that the ferrules were manufactured, sampled, tested, and inspected in accordance with this specification and have been found to meet the requirements. When specified in the purchase order or contract, a report of design test shall be furnished.

29. Product Marking

29.1 Ferrules shall be marked with the manufacturer's identity code.

30. Packaging

30.1 Each shipment shall be packaged to provide protection of the contents appropriate for the mode of transportation.

CABLES FOR TEMPORARY PROTECTIVE GROUNDS

31. Scope

31.1 This specification covers the elastomer or thermoplastic covered flexible cable used with ferrules, clamps, and connectors in the manufacture of protective grounds, installed temporarily for protective grounding of de-energized circuits.

32. Classification

32.1 Grounding cables have flexible elastomer or thermoplastic jackets primarily for mechanical protection of the conductor it covers.

32.2 Electrical characteristics shall be in accordance with Table 2 or Table 3. See Appendix X3 for a discussion and derivation of the current levels. See Appendix X4 for a discussion of the effects of asymmetrical current.

32.3 Grounding cables are furnished in three types, as follows:

32.3.1 *Type I*—Cables shall have stranded soft drawn copper conductor with stranding of 665 wires or more #30 AWG (0.254 mm/0.0100 in. diameter) or #34 AWG (0.160 mm/0.0063 in. diameter) wire, and elastomer jackets rated by the manufacturer flexible for installation and serviceable for continuous use at temperatures ranging from -40°C (-40°F) through $+90^{\circ}\text{C}$ ($+194^{\circ}\text{F}$).

32.3.2 *Type II*—Cables shall have stranded soft drawn copper conductor with stranding of 133 wires or more for Size #2, or 259 wires or more for size 1/0 and larger, and elastomer jackets rated by the manufacturer flexible for installation and serviceable for continuous use at temperatures ranging from -25°C (-13°F) to $+90^{\circ}\text{C}$ ($+194^{\circ}\text{F}$).

32.3.3 *Type III*—Cables shall have stranded soft drawn copper conductor with stranding of 665 wires or more #30 AWG (0.0100 in. diameter) and thermoplastic jackets rated by the manufacturer flexible for installation and serviceable for continuous use at temperatures ranging from -10°C ($+14^{\circ}\text{F}$) through $+60^{\circ}\text{C}$ ($+140^{\circ}\text{F}$).

NOTE 5—**Caution:** The use of Type III jacketed cables is restricted to open areas or spaces with adequate ventilation, so that fumes which could be produced by overheating the jacket during a short circuit fault on the cable can be dispersed.



32.4 Nonstandard cables and conductors which meet the electrical requirements of standard cables in accordance with Table 2 or 5 may be utilized at the discretion of the user.

33. Size

33.1 Cable sizes shall be stated in American Wires Gage numbers (AWG). (See Table 7 for standard sizes and a comparison of AWG and SI wire sizes.)

34. Ordering Information

34.1 Orders for cables under this specification shall include this ASTM designation and the following information:

- 34.1.1 Quantity,
- 34.1.2 Unit of measure, (feet or meters),
- 34.1.3 Type (see Section 32),
- 34.1.4 Size (see Section 33), and
- 34.1.5 Conductor material, if other than Type I, Type II, or Type III.

NOTE 6—A typical ordering description is as follows: 100 feet ASTM F855 Type I Copper Grounding Cable 1/0 AWG.

NOTE 7—It is expected that manufacturers will publish catalog data conforming to this specification which will combine the requirements of 34.1.3-34.1.5 in a single product number. With that system, a typical order description is as follows: 100 ft (Smith Manufacturing Co. Product No. XXXXX) Grounding Cable, ASTM F855, Type I.

35. Materials

35.1 Copper Conductor:

35.1.1 *Type I Cables*— Specification B 172, Class K or M, or bunch stranded equal, copper.

35.1.2 *Type II Cables*— Specification B 173, Class H, Specification B 172, Class I, K, or M, or bunch stranded equal, copper.

35.1.3 *Type III Cables*— Specification B 172, Class K, or bunch stranded equal, copper.

35.1.4 Except as otherwise modified by this specification, grounding cables shall conform to the dc resistance requirements of Table 6.5-1 of ICEA S-19-81/NEMA WC 3-80 (R 1986).

35.1.5 See Table 8 for cable stranding.

35.2 Jacketing:

35.2.1 *General*—The jacket material shall be flexible without cracking within the temperature ranges established in 32.2.

35.2.2 *Thickness*—All grounding cable jackets covered by this specification shall have a minimum thickness of 1.14 mm (0.045 in.).

35.2.3 Material:

35.2.3.1 All jacket material shall conform to Specifications D 753 (for polychloroprene), D2768 and D2770 (for ethylene propylene rubber), and D2219 (for PVC combinations).

35.2.3.2 Thermoplastic rubber, when used, shall possess the following:

Tensile strength, min (1500 psi)	10.3 MPa
Elongation, min	250 %

35.2.3.3 Sample after aging by heat (oven for 168 h at 70 ± 1°C) and oil immersion (18 h at 121 ± 1°C) at 75 % of original values.

36. Workmanship, Finish, and Appearance

36.1 Cable shall be free of structural defects that affect installation, assembly, or performance.

36.2 Minor surface irregularities that do not affect strength or performance are not cause for rejection.

37. Sampling

37.1 Sampling for jacket tests shall be in accordance with Methods D 470.

37.2 Sampling for Electrical Short Circuit Testing:

37.2.1 A product model represents a manufacturer's design specification according to which production lot is manufactured.

37.2.2 A production lot shall consist of all cable of one product model produced at one time.

37.2.3 A test sample shall consist of two specimens of cable, each a minimum of 3 m (10 ft) long, selected at random from a production lot for each different test specified. When a failure occurs in one specimen from the first sample, a second sample shall be selected from the same lot and tested. If the second sample (two specimens) passes, the lot shall be accepted. If one specimen from the second sample fails, the lot shall be rejected.

38. Tests

38.1 The testing of jackets shall conform to Test Methods D 470 and D 2633 and 35.2.3.2.

39. Protective Cable Ratings

39.1 The current values listed in Table 2 are divided into three general headings: withstand, ultimate and continuous. Table 3 lists ultimate only.

39.1.1 *Continuous Capacity*—Designated RMS current which the cable can carry under specified conditions.

39.2 Current-Carrying Capabilities:

39.2.1 Table 1 and Table 2 currents are based upon the fusing (melting) current-time values for copper derived from I. M. Onderdonk's equation (see Fig. 2 and Appendix X3). The cable thus tested might be damaged and shall not be reused

TABLE 7 AWG Versus Metric Wire Sizes

Circular Mils	Equivalent Circular Mils	AWG Size	Metric Wire Size, mm ²
...	365 100	...	185
350 000
300 000	150
250 000
...	237 800	...	120
211 600	...	4/0	...
...	187 500	...	95
...	187 500	...	95
167 800	...	3/0	...
167 800	...	3/0	...
...	138 100	...	70
133 100	...	2/0	...
105 600	...	1/0	...
...	98 680	...	50
83 690	...	1	...
...	69 070	...	35
...	69 070	...	35
66 360	...	2	...



TABLE 8 Rope Lay Stranded Copper Conductors

Area of Cross Section, cmils	AWG Size	Class H		Class I		Class K		Class M		
		No. of Wires	Dia of Wires, mils	No. of Wires in each Member	No. of Wires 0.0201 in. In Dia (#24 AWG)	Strand Construction	No. of Wires 0.0100 in. in Dia (#30 AWG)	Strand Construction	No. of Wires 0.0063 in. In Dia (#34 AWG)	Strand Construction
350 000	...	427	28.6	7	882	7 × 7 × 18	3458	19 × 7 × 2*6	8806	37 × 7 × 34
300 000	...	427	26.5	7	735	7 × 7 × 15	2989	7 × 7 × 61	7581	19 × 7 × 57
250 000	...	427	24.2	7	637	7 × 7 × 13	2499	7 × 7 × 51	6384	19 × 7 × 48
211 600	4/0	259	28.6	7	532	19 × 28	2107	7 × 7 × 43	5320	19 × 7 × 40
167 800	3/0	259	25.5	7	418	19 × 22	1666	7 × 7 × 34	4256	19 × 7 × 32
133 100	2/0	259	22.7	7	342	19 × 18	1323	7 × 7 × 27	3325	19 × 7 × 25
105 600	1/0	259	20.2	7	266	19 × 14	1064	19 × 56	2646	7 × 7 × 54
66 360	#2	133	22.3	7	161	7 × 23	665	19 × 35	1666	7 × 7 × 34

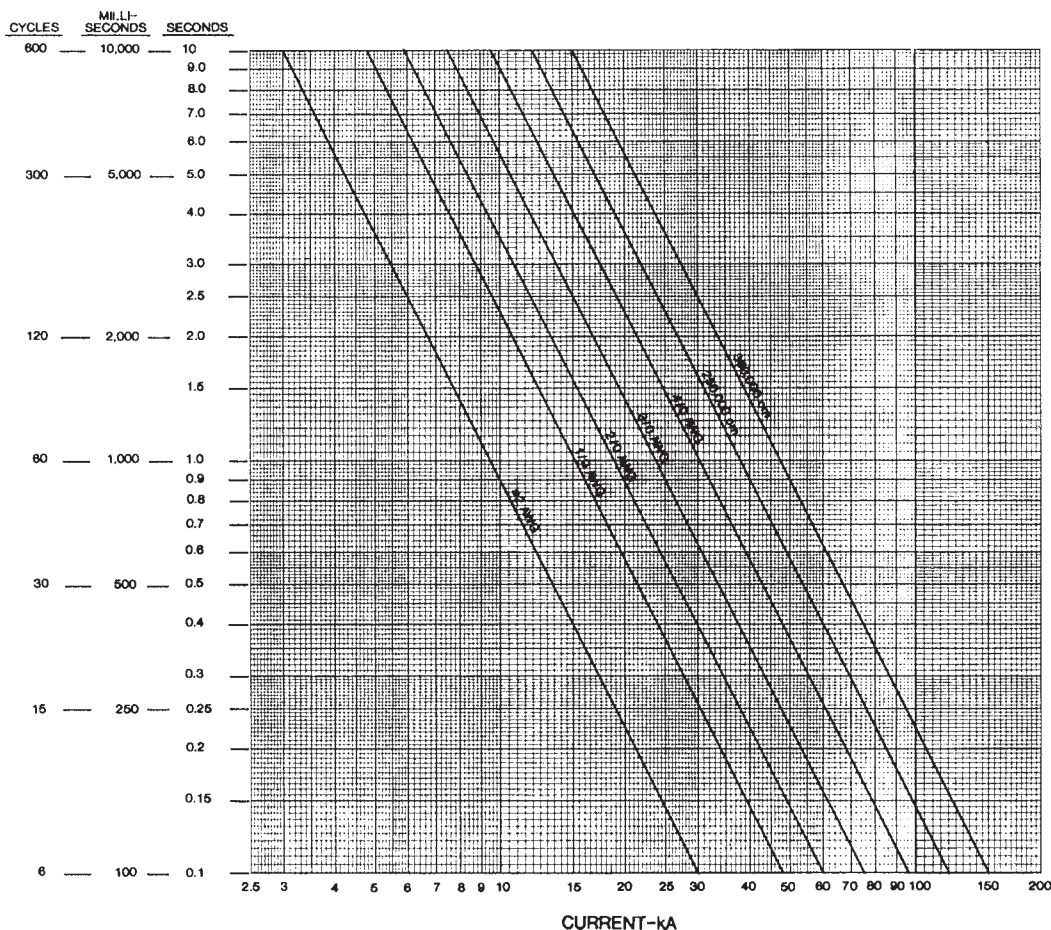

FIG. 2 Fusing Current Versus Time for Copper Conductors

except in testing situations. Table 1 and Table 2 are based on performance with surges not exceeding 20 % asymmetry factor.

39.2.2 The values shown in Table 3a, Table 3b, and Table 3c are derived from EPRI Project RP2446 Computer Program RTGC, “A Desktop Computer Program for Calculating Rating of Temporary Grounding Cables.” See Appendix X4 for a discussion of asymmetrical current resulting from higher X/R ratios and further recommendations.

39.2.3 The rationalization for detailing the grounding cable ratings in the manner in which it is presented is that it enables the user to choose which cable and which rating is required for the user’s system and company’s philosophy.

39.2.3.1 The choice of a withstand rating is conservative in that larger cables will generally be required, but may allow grounding sets to be reused after being subjected to a short circuit fault. Users should verify to their own satisfaction that the cable can be reused.

39.2.3.2 Fig. 2 provides guidance to users in selecting grounding cables if the user wishes to exceed the withstand values in rating the grounding cables. The user must recognize that the ultimate capacity of Table 2 and Table 3 is the calculated capacity of the cable at which melting or failure will occur. A suitable safety margin shall be maintained in selecting the cable size.

39.2.3.3 The derived current-carrying capabilities shown in Table 3a, Table 3b, and Table 3c may allow a higher current for a given size-time combination. These values take advantage of actual tests that have considered the added quality due to stranding, or jacket, or both.

ASSEMBLED TEMPORARY PROTECTIVE GROUNDS

40. Scope

40.1 This specification covers temporary protective grounds assembled with clamps, ferrules, and elastomercovered flexible cable primarily intended to be installed temporarily for protective grounding of de-energized circuits.

41. Classification

41.1 Protective grounds may be furnished with various combinations of clamps including, but not limited to, the following:

41.1.1 *Design I*—Protective grounds are equipped with a conductor clamp (Type I or Type II) on each end of the cable.

41.1.2 *Design II*—Protective grounds are equipped with a conductor clamp (Type I or Type II) on one end of the cable, and a ground clamp (Type III) on the other end.

41.1.3 *Design III*—Protective grounds are equipped with a ground clamp (Type III) on each end of the cable.

41.1.4 *Design IV*—Protective grounds are equipped with either a conductor or ground clamp on one end of the cable and a special (ground cluster or other) clamp at the other end.

41.1.5 *Design V*—Protective grounds are equipped with various special clamps or fittings designed for use on underground equipment.

41.2 Protective grounds are furnished in grades according to short circuit capabilities and duration of faults as indicated in Table 1.

41.3 Protective grounds are furnished in two classes according to the characteristics of the clamp main contact jaws:

41.3.1 *Class A*—Protective grounds have conductor clamps with jaws having smooth (without serration or cross hatching) contact surfaces.

41.3.2 *Class B*—Protective grounds have conductor clamps with jaws having serrations or cross hatching or other means intended to abrade or bite through corrosion products on the surfaces of the conductor being clamped.

42. Sizes

42.1 Protective grounds size is the combination of the main contact and cable size range as listed by the manufacturers. Cable lengths shall be as specified by the purchaser, and the measured length shall include cables and their ferrules prior to securing to the clamp(s).

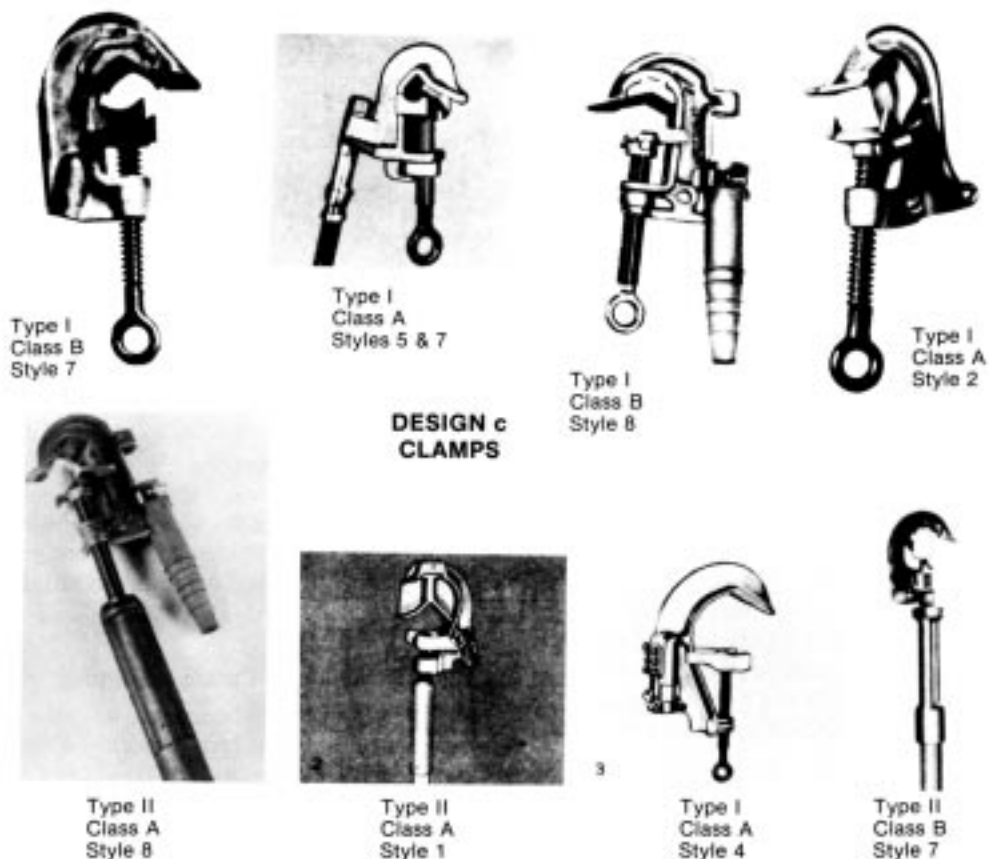

FIG. 3 Design c Clamps



FIG. 4 Design ca Clamps

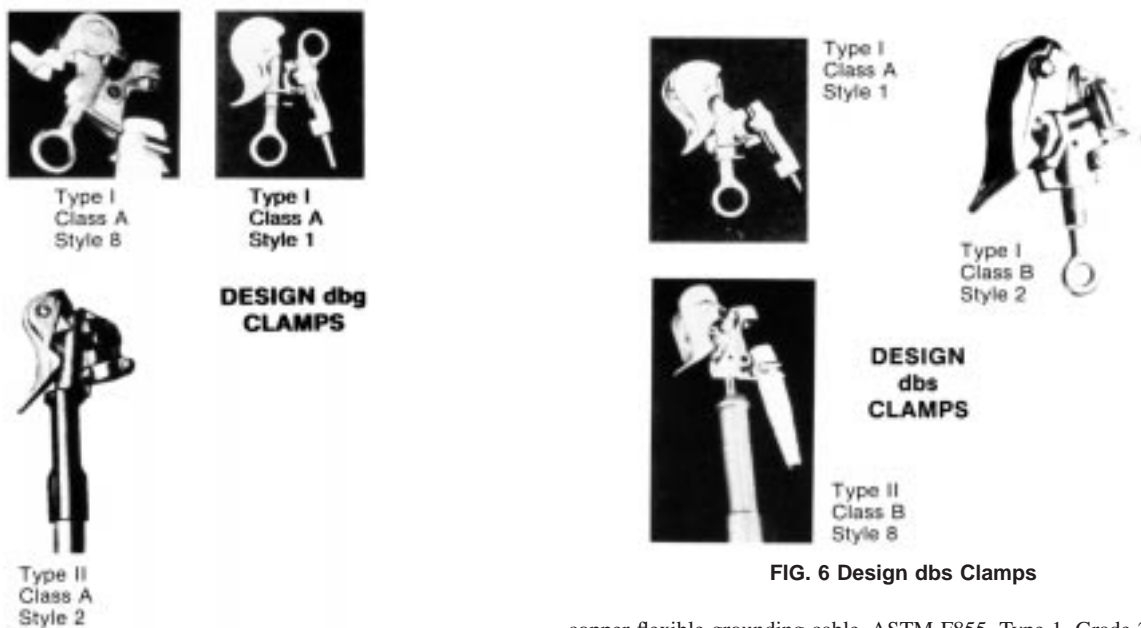

FIG. 5 Design dbg Clamps

FIG. 6 Design dbs Clamps

43. Ordering Information

43.1 Orders for protective grounds under this specification shall include this ASTM designation and the following information:

- 43.1.1 Quantity,
- 43.1.2 Name (Protective Ground),
- 43.1.3 Main clamp contact size ranges, conductor description, and materials which are to be clamped by main contact of clamp on each end of cable,
- 43.1.4 Cable size, lengths, material, and description by which protective grounds are to be assembled,
- 43.1.5 Type (see 41.1),
- 43.1.6 Grade for each component; grade of protective ground assembly assumes grade of lowest graded component (see 41.2 and Table 1),
- 43.1.7 Class (see 41.3), and
- 43.1.8 Asymmetrical current or other supplementary requirements, if applicable (see Supplementary Requirements S1 to S10).

NOTE 8—A typical ordering description is as follows: 100 protective grounds, main contact range #2 to 350 kcmil with 6 ft (1.828 m) 2/0

copper flexible grounding cable, ASTM F855, Type 1, Grade 2, Class A, Design C, Style 7 or X/R maximum, in addition to the grade designation.

NOTE 9—It is expected that manufacturers will publish catalog data on clamps, cables, and ferrules conforming to this specification: 100 protective grounds, ASTM F855, each as follows: one (Manufacturer's Catalog No.) clamp one end, 10 ft (Manufacturer's Catalog No.) cable, one (Manufacturer's Catalog No.) clamp one end, and two each or one pair (Manufacturer's Catalog No.) cable ferrules. Manufacturers may catalog protective grounds combining the requirements of 43.1.2-43.1.8, by specific catalog numbers to simplify ordering description, as follows: 100 # (Manufacturer's Catalog No.) Protective Grounds, ASTM F855.

44. Materials

44.1 Clamps, cables, and ferrules shall meet the requirements prescribed in these specifications and Test Methods E 8.

45. Electrical and Mechanical Properties

45.1 Electrical and mechanical properties shall conform to the requirements prescribed in Table 2 or Table 3, as appropriate. See Appendix X3 for a discussion and the derivation of these current levels. See Appendix X4 for a discussion of the effects of asymmetrical current.

46. Workmanship, Finish, and Appearance

46.1 Components shall be free of structural porosity, fins, sharp edges, splits, cracks, and other defects that affect handling or performance.

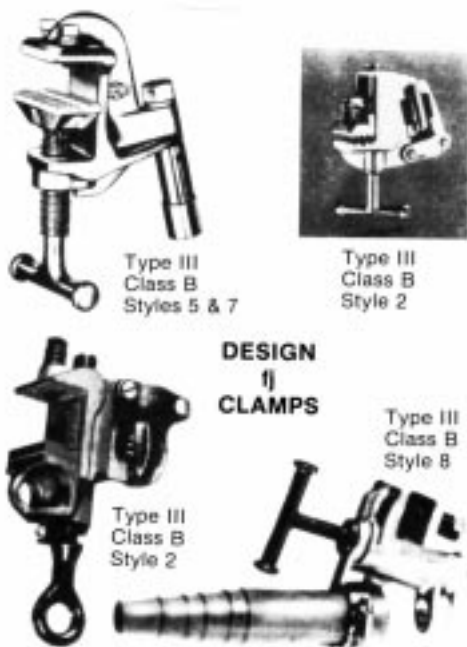

FIG. 7 Design fj Clamps



FIG. 8 Design fjk Clamp

46.2 All parts shall be formed, machined, and assembled with sufficient accuracy for smooth operation by hand. Clamps shall be free of excessive looseness to the extent detrimental to repeated applications at recommended installing torque.

46.3 Clamps, cables, and ferrules shall be assembled tightly and securely to develop the full short circuit capacity specified in Table 1 or Table 3 as appropriate.



FIG. 9 Design ha Clamp

47. Sampling

47.1 A component product model represents a manufacturer's design specification standard according to which the product model is manufactured.

47.2 A production lot shall consist of all protective grounds of one product model produced at one time.

47.3 A test sample consists of two specimens of protective grounds selected at random from a production lot for each different test specified. When a failure occurs in one specimen from the first sample, a second sample shall be selected from the same lot and tested. If the second sample (two specimens) passes, the lot shall be accepted. If one specimen from the second sample fails, the lot shall be rejected.

48. Design Tests

48.1 Test samples of each component product model shall have been tested by the manufacturer or supplier to verify conformance with the performance requirements of these specifications and Methods E 8.

49. Inspection and Production Testing

49.1 Inspection and production testing shall include the following:

49.1.1 Main contact capacities of grounding clamps in accordance with 9.1.2 and 9.1.3,

49.1.2 Visual inspection and hand operation of grounding clamps to verify workmanship, finish, appearance, and tight and secure assembly in accordance with Section 46, and

49.1.3 Verification that the clamps, ferrules and cable sizes, and lengths are as specified by purchaser.

50. Acceptance, Rejection, and Rehearing

50.1 At the option of the purchaser, a production lot may be subjected to the following:

50.1.1 Inspection in accordance with Section 49 for operation, main contact range, workmanship, and appearance. Individual components or permanent assemblies that do not conform may be rejected.

**CABLE TERMINATIONS AND COMPATIBLE CABLE
FERRULES FOR GROUNDING CLAMPS**



FIG. 10 Cable Terminations and Compatible Cable Ferrules for Grounding Clamps

50.1.2 Resistance comparison test of clamps in accordance with 9.1.

50.1.3 Material that fails to conform to the requirements of this specification may be rejected. Rejection should be reported to the producer or supplier promptly and in writing. In case of dissatisfaction with the results of the test, the producer or supplier may make claim for a rehearing.

50.1.4 If electrical testing, or mechanical testing, or both, is required by a user prior to acceptance or for in service testing, it shall be done in accordance with the criteria set down in these specifications for any part or complete assembly, as required.

51. Certification

51.1 When specified in the purchase order or contract, a producer's or supplier's certification shall be furnished to the purchaser that the components and assemblies were manufactured, sampled, tested, and inspected in accordance with this specification and have been found to meet the requirements.

52. Packaging and Package Marking

52.1 Each shipment shall be packaged to provide protection of the contents appropriate for the mode of transportation.

CABLE TERMINATIONS AND COMPATIBLE CABLE FERRULES FOR GROUNDING CLAMPS

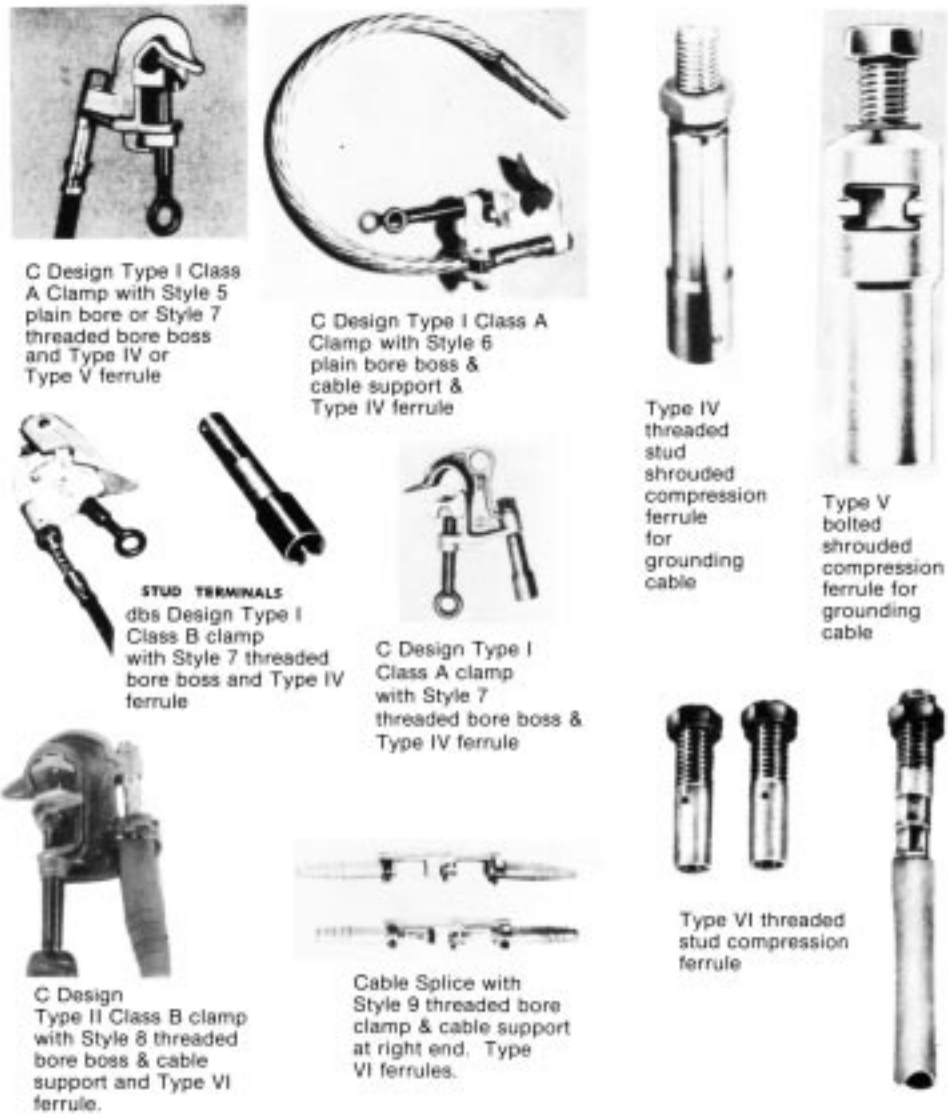

FIG. 11 Cable Terminations and Compatible Cable Ferrules for Grounding Clamps

52.2 A packing list indicating the manufacturer's product numbers and quantities of each different clamp shall be provided with each shipment.



SUPPLEMENTARY REQUIREMENTS

One or more of the following supplementary requirements shall be applied only when specified by purchaser in the inquiry, contract, or order. Details shall be agreed on by the producer or supplier and the purchaser. Supplementary requirements shall in no way negate any requirement of the specification itself.

CLAMPS AND CABLES FOR TEMPORARY PROTECTIVE GROUNDING SYSTEMS

S1. Specific shape or design illustrated in Figs. 3-11 with designations as follows:

"C" shape clamps	design c
"C" adjustable size clamp	design ca
Duckbill gravity actuated clamp	design dbg
Duckbill spring loaded clamp	design dbs
Flat jaw clamp	design fj
Flat jaw clamp with keeper	design fjk
Hinged arm clamp	design ha

S2. *Specific Cable Termination Design*—These are included with matching cable ferrules in Figs. 3-11. Styles are as follows:

Style 1 Cable retaining eyebolt
Style 2 Eyebolt and cable support
Style 3 Plain bore bolted clamp and cable support
Style 4 Plain bore tubular with screws and cable support
Style 5 Plain bore boss
Style 6 Plain bore boss and cable support
Style 7 Threaded bore boss
Style 8 Threaded bore boss and cable support
Style 9 Threaded bore bolted clamp and cable support

S3. Bending stress relief component for cable termination.

S4. Design of clamp not included in Figs. 3-11.

S5. Specific short circuit requirement other than as specified in Table 1.

S6. Material(s) more strictly specified than included in Section 8.

S7. Main conductor size, description, or material other than covered by manufacturer's standard products made to this specification.

S8. Cable size, description, material, or termination specification other than provided by manufacturer's standard products made to this specification.

S9. Additional product marking, labeling.

S10. Special packaging.

CABLE FERRULES FOR TEMPORARY PROTECTIVE GROUNDS

S11. Type other than specified in 18.1.1-18.1.5.

S12. Specific short circuit requirement other than as specified in Table 2 or Table 3.

S13. Physical requirements other than as shown in Table 5.

S14. Materials more strictly specified than included in Section 21.

S15. Additional product marking, labeling.

S16. Special packaging.

S17. Cadweld is not intended for use in protective grounds.

APPENDIXES

(Nonmandatory Information)

X1. MANUFACTURE OF GROUNDING CABLE

X1.1 It is recognized that most of the grounding cables in use today are actually made for another purpose, such as welding. These cables are constructed in accordance with the suitable ASTM standard and in most circumstances have performed well.

X1.2 Although grounding cable is cable that was constructed for another purpose, it has an excellent record in the utility industry. Numerous short circuit tests have been per-

formed for specific application, and the results have been perfect as to quality of construction. This tremendous sampling has indicated that this cable manufactured for another purpose is acceptable as a grounding cable.

X1.3 Should a specific ASTM standard be required and accepted for grounding cables, this specification will be revised to include the appropriate information.



X2. COMMENTARY

X2.1 It is recognized that these specifications are not entirely complete. More work will be done on testing and application in the future.

X2.2 It is recognized that a void may exist in the application where these specifications are not considered.

X2.3 Although this standard is not in its ultimate form, it does present solid, practical, and usable information. It is intended that these specifications be updated and improved whenever additional information is available.

X3. DISCUSSION OF CABLE FUSING

X3.1 A discussion of Onderdonk's Equation and E. R. Stauffacher's chart taken from the *Standard Handbook for Electrical Engineers*,⁹ Pages 4 to 84, reprinted with the permission. Fusing current-time for copper conductors and connections may be determined by an equation developed by I. M. Onderdonk:

$$33 (I/A)^2 S = \log ((T_m - T_a)/(234 + T_a) + 1)$$
$$I = A (\log ((T_m - T_a)/(234 + T_a) + 1))$$

where:

- I = current in amperes,
- A = conductor area in circular mils,
- S = time current applied in seconds,
- T_m = melting point of copper, °C, and
- T_a = ambient temperature, °C.

X3.1.1 *Copper Conductors*—These currents are nominal calculated values for bare copper at an ambient temperature of 40°C. E. R. Stauffacher has prepared a chart of the fusing current for sizes from 30 AWG to 500 000 cmils from 0.1 to 10 s. This chart is based on the assumptions that (I) radiation may

be neglected owing to the short time involved, that is, 10 s; (2) resistance of 1 cm cube of copper at 0°C is 1.589 $\mu\Omega$; (3) temperature-resistance coefficient of copper at 0°C is 1/234; (4) melting point of copper is 1083°C; and (5) ambient temperature is 40°C.

X3.1.2 Solder shall not be used, except for weatherproofing purposes.

X3.1.3 *Bolted Connections*—Generally accepted value of T_m is 250°C.⁹

X3.2 *Discussion of "A Desktop Computer Program for Calculating Rating of Temporary Grounding Cables"*—The values shown in Table 3a, Table 3b, and Table 3c are derived from EPRI Project RP2446 Computer Program RTGC, "A Desktop Computer Program for Calculating Rating of Temporary Grounding Cables." The program is based on an approach suggested by V. T. Morgan ("Rating of Cables for Short Duration Currents," IEEE Volume 118, No. 3/4, March/April 1971) which assumes that cable parameters such as resistance, specific heat capacity, linear dimensions, density, and thermal conductivity are quadratic functions of temperature. The derived values listed in the tables are supported by an adequate number of actual fault tests on 1/0 Class K cables (see Table 8) to ensure a high confidence level for the program.

⁹ Fink, and Beatty, *Standard Handbook for Electrical Engineers*, Eleventh ed., McGraw-Hill, New York, NY, 1978, pp. 4–84.

X4. EFFECT OF ASYMMETRICAL CURRENTS ON TEMPORARY PROTECTIVE GROUNDING EQUIPMENT

X4.1 At de-energized work sites, with temporary protective grounds in place, available fault currents from all sources must be considered. ASTM F855 was originally written around cable fusing equations developed by I. M. Onderdonk (see Appendix X3). Table 1 and Table 2 are based upon these equations, and consider conductor melting only. They reflect a near symmetrical current, as indicated by the footnote, which limits to a maximum asymmetry of 20 %. This limits the X/R ratio to a maximum of approximately 1.8. The success of these tables has been due in large part to lower current values and a worksite location remote from a substation or switchyard.

X4.2 As available fault current levels have increased, and work near or within substations is also required, additional guidelines became necessary. An EPRI study was conducted which provides some guidance in these situations. The study included tests on full-size protective grounds. This provided a consideration of the mechanical forces created from the cable

whipping at high currents, as well as melting or fusing times. Table 3a, Table 3b and Table 3c report ultimate values at three X/R levels. Table 3a is based on an X/R of 40, a typical value for many substations. The midrange, Table 3b, reflects an X/R of 10 and Table 3c is for an X/R of 0. It should be noticed that the values of ultimate current of Table 1 and Table 2 are substantially the same as those in Table 3 for values up to an $X/R = 10$.

X4.3 The variation in X/R values result in substantially different asymmetrical currents. The greater the X/R , the greater the instantaneous peak current, and the longer the time required for the asymmetrical current to return to a symmetrical form.

X4.4 Asymmetrical current is defined by the following equation:

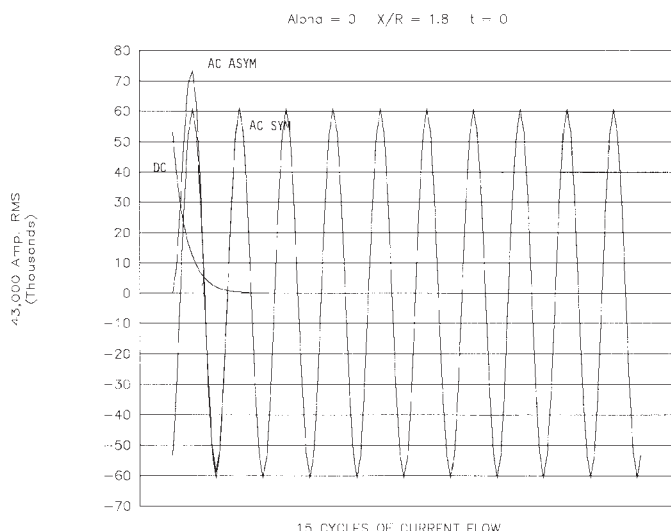

FIG. X4.1 15 Cycles of Current Flow

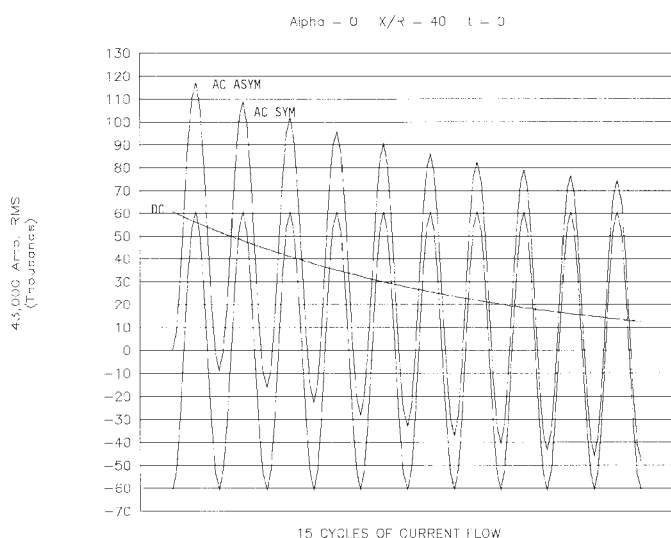

FIG. X4.2 15 Cycles of Current Flow

$$i = |V_m/Z|[\sin(\omega t + \alpha - \theta) - e^{-Rt/L}\sin(\alpha - \theta)]$$

$$= |I|[\sin(\omega t + \alpha - \theta) - e^{-\alpha R t/X}\sin(\alpha - \theta)]$$

where:

- $|V_m|$ = peak voltage available, v ,
- $|Z|$ = circuit impedance, Ω ,
- $|I|$ = peak current available, A ,

- R = circuit resistance, Ω ,
- t = time from current initiation,
- ω = $2\pi f$ (radians/s),
- f = frequency, H ,
- α = voltage angle at current initiation, radians,
- θ = circuit phase angle, radians, and
- L = circuit inductance X/W , Ω .

X4.4.1 Study of the equation shows that a near maximum instantaneous peak occurs when $t = 0$ and $\alpha = 0$. The equation is divided into two parts. The sine function represents the symmetrical AC portion. The exponential function represents the decaying DC portion. The summation of the AC and DC portions yields the asymmetrical wave. Also indicated is that the exponential decay of the transient portion is slowed as the X/R increases.

X4.5 Asymmetrical currents are measured as described in ANSI C37.09-1979 (R-1989) Section 7. It is an instantaneous measurement, in that the values may vary with time.

X4.6 Fig. X4.3 and Fig. X4.4 illustrate the variations due to differing X/R ratios. The two figures represent an ASTM Grade 5 assembly, rated 43 000 RMS amperes, at two X/R values. The larger peak currents result in increased heating of the assembly and increased mechanical forces on the clamps. Failure to take this into account may result in the loss of worker protection.

X4.7 Further review of the EPRI study should be conducted if the ultimate current limitations are approached at a worksite which also has a higher X/R present.

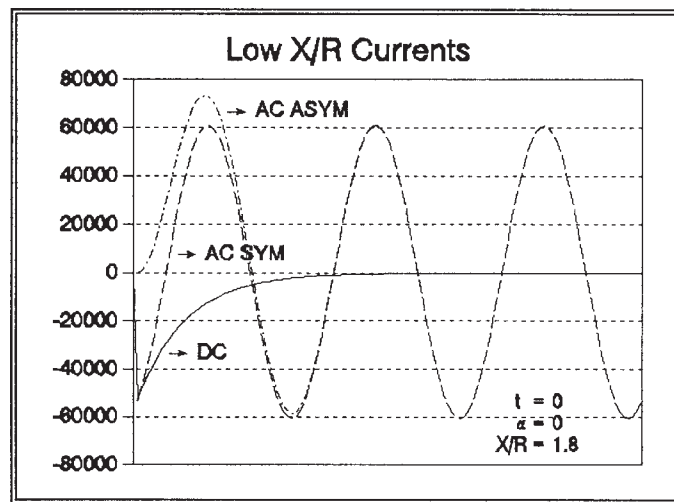

FIG. X4.3 Low X/R Currents

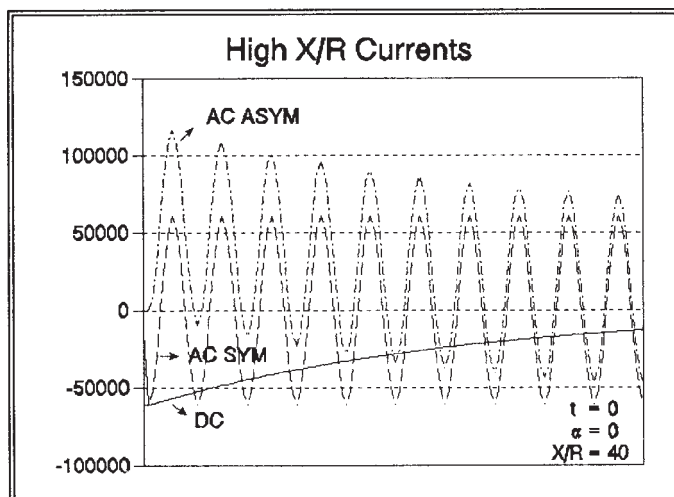

FIG. X4.4 High X/R Currents

The American Society for Testing and Materials takes no position respecting the validity of any patent rights asserted in connection with any item mentioned in this standard. Users of this standard are expressly advised that determination of the validity of any such patent rights, and the risk of infringement of such rights, are entirely their own responsibility.

This standard is subject to revision at any time by the responsible technical committee and must be reviewed every five years and if not revised, either reapproved or withdrawn. Your comments are invited either for revision of this standard or for additional standards and should be addressed to ASTM Headquarters. Your comments will receive careful consideration at a meeting of the responsible technical committee, which you may attend. If you feel that your comments have not received a fair hearing you should make your views known to the ASTM Committee on Standards, at the address shown below.

This standard is copyrighted by ASTM, 100 Barr Harbor Drive, PO Box C700, West Conshohocken, PA 19428-2959, United States. Individual reprints (single or multiple copies) of this standard may be obtained by contacting ASTM at the above address or at 610-832-9585 (phone), 610-832-9555 (fax), or service@astm.org (e-mail); or through the ASTM website (www.astm.org).