



Designation: F 76 – 86 (Reapproved 1996)^{ε1}

Standard Test Methods for Measuring Resistivity and Hall Coefficient and Determining Hall Mobility in Single-Crystal Semiconductors¹

This standard is issued under the fixed designation F 76; the number immediately following the designation indicates the year of original adoption or, in the case of revision, the year of last revision. A number in parentheses indicates the year of last reapproval. A superscript epsilon (ε) indicates an editorial change since the last revision or reapproval.

^{ε1} NOTE—Keywords were added editorially in February 1997.

1. Scope

1.1 These test methods cover two procedures for measuring the resistivity and Hall coefficient of single-crystal semiconductor specimens. These test methods differ most substantially in their test specimen requirements.

1.1.1 *Test Method A, van der Pauw (1)*²—This test method requires a singly connected test specimen (without any isolated holes), homogeneous in thickness, but of *arbitrary* shape. The contacts must be sufficiently small and located at the periphery of the specimen. The measurement is most easily interpreted for an isotropic semiconductor whose conduction is dominated by a single type of carrier.

1.1.2 *Test Method B, Parallelepiped or Bridge-Type*—This test method requires a specimen homogeneous in thickness and of *specified* shape. Contact requirements are specified for both the parallelepiped and bridge geometries. These test specimen geometries are desirable for anisotropic semiconductors for which the measured parameters depend on the direction of current flow. The test method is also most easily interpreted when conduction is dominated by a single type of carrier.

1.2 These test methods do not provide procedures for shaping, cleaning, or contacting specimens; however, a procedure for verifying contact quality is given.

NOTE 1—Practice F 418 covers the preparation of gallium arsenide phosphide specimens.

1.3 The method in Practice F 418 does not provide an interpretation of the results in terms of basic semiconductor properties (for example, majority and minority carrier mobilities and densities). Some general guidance, applicable to certain semiconductors and temperature ranges, is provided in the Appendix. For the most part, however, the interpretation is left to the user.

1.4 Interlaboratory tests of these test methods (Section 19) have been conducted only over a limited range of resistivities

and for the semiconductors, germanium, silicon, and gallium arsenide. However, the method is applicable to other semiconductors provided suitable specimen preparation and contacting procedures are known. The resistivity range over which the method is applicable is limited by the test specimen geometry and instrumentation sensitivity.

1.5 The values stated in acceptable metric units are to be regarded as the standard. The values given in parentheses are for information only. (See also 3.1.4.)

1.6 *This standard does not purport to address all of the safety concerns, if any, associated with its use. It is the responsibility of the user of this standard to establish appropriate safety and health practices and determine the applicability of regulatory limitations prior to use.*

2. Referenced Documents

2.1 ASTM Standards:

D 1125 Test Methods for Electrical Conductivity and Resistivity of Water³

E 177 Practice for Use of the Terms Precision and Bias in ASTM Test Methods⁴

F 26 Test Methods for Determining the Orientation of a Semiconductive Single Crystal⁵

F 43 Test Methods for Resistivity of Semiconductor Materials⁵

F 47 Test Method for Crystallographic Perfection of Silicon by Preferential Etch Techniques⁵

F 418 Practice for Preparation of Samples of the Constant Composition Region of Epitaxial Gallium Arsenide Phosphide for Hall Effect Measurements⁵

2.2 SEMI Standard:

C1 Specifications for Reagents⁶

3. Terminology

3.1 Definitions:

3.1.1 *Hall coefficient*—the ratio of the Hall electric field (due to the Hall voltage) to the product of the current density

¹ These test methods are under the jurisdiction of ASTM Committee F-1 on Electronics and are the direct responsibility of Subcommittee F01.15 on Gallium Arsenide.

Current edition approved Oct. 31, 1986. Published December 1986. Originally published as F 76 – 67T. Last previous edition F 76 – 84.

² The boldface numbers in parentheses refer to the list of references at the end of these test methods.

³ *Annual Book of ASTM Standards*, Vol 11.01.

⁴ *Annual Book of ASTM Standards*, Vol 14.02.

⁵ *Annual Book of ASTM Standards*, Vol 10.05.

⁶ Available from Semiconductor Equipment and Materials Institute, 625 Ellis St., Suite 212, Mountain View, CA 94043.

and the magnetic flux density (see X1.4).

3.1.2 *Hall mobility*—the ratio of the magnitude of the Hall coefficient to the resistivity; it is readily interpreted only in a system with carriers of one charge type. (See X1.5)

3.1.3 *resistivity—of a material*, is the ratio of the potential gradient parallel to the current in the material to the current density. For the purposes of this method, the resistivity shall always be determined for the case of zero magnetic flux. (See X1.2.)

3.1.4 *units*—in these test methods SI units are not always used. For these test methods, it is convenient to measure length in centimetres and to measure magnetic flux density in gauss. This choice of units requires that magnetic flux density be expressed in $V \cdot s \cdot cm^{-2}$ where:

$$1 V \cdot s \cdot cm^{-2} = 10^8 \text{ gauss}$$

The units employed and the factors relating them are summarized in Table 1.

4. Significance and Use

4.1 In order to choose the proper material for producing semiconductor devices, knowledge of material properties such as resistivity, Hall coefficient, and Hall mobility is useful. Under certain conditions, as outlined in the Appendix, other useful quantities for materials specification, including the charge carrier density and the drift mobility, can be inferred.

5. Interferences

5.1 In making resistivity and Hall-effect measurements, spurious results can arise from a number of sources.

5.1.1 Photoconductive and photovoltaic effects can seriously influence the observed resistivity, particularly with high-resistivity material. Therefore, all determinations should be made in a dark chamber unless experience shows that the results are insensitive to ambient illumination.

5.1.2 Minority-carrier injection during the measurement can also seriously influence the observed resistivity. This interference is indicated if the contacts to the test specimen do not have linear current-versus-voltage characteristics in the range used in the measurement procedure. These effects can also be detected by repeating the measurements over several decades of current. In the absence of injection, no change in resistivity

should be observed. It is recommended that the current used in the measurements be as low as possible for the required precision.

5.1.3 Semiconductors have a significant temperature coefficient of resistivity. Consequently, the temperature of the specimen should be known at the time of measurement and the current used should be small to avoid resistive heating. Resistive heating can be detected by a change in readings as a function of time starting immediately after the current is applied and any circuit time constants have settled.

5.1.4 Spurious currents can be introduced in the testing circuit when the equipment is located near high-frequency generators. If equipment is located near such sources, adequate shielding must be provided.

5.1.5 Surface leakage can be a serious problem when measurements are made on high-resistivity specimens. Surface effects can often be observed as a difference in measured value of resistivity or Hall coefficient when the surface condition of the specimen is changed (2, 3).

5.1.6 In measuring high-resistivity samples, particular attention should be paid to possible leakage paths in other parts of the circuit such as switches, connectors, wires, cables, and the like which may shunt some of the current around the sample. Since high values of lead capacitance may lengthen the time required for making measurements on high-resistivity samples, connecting cable should be as short as practicable.

5.1.7 Inhomogeneities of the carrier density, mobility, or of the magnetic flux will cause the measurements to be inaccurate. At best, the method will enable determination only of an undefined average resistivity or Hall coefficient. At worst, the measurements may be completely erroneous (2, 3, 4).

5.1.8 Thermomagnetic effects with the exception of the Ettingshausen effect can be eliminated by averaging of the measured transverse voltages as is specified in the measurement procedure (Sections 11 and 17). In general, the error due to the Ettingshausen effect is small and can be neglected, particularly if the sample is in good thermal contact with its surroundings (2, 3, 4).

5.1.9 For materials which are anisotropic, especially semiconductors with noncubic crystal structures, Hall measurements are affected by the orientation of the current and

TABLE 1 Units of Measurement

Quantity	Symbol	SI Unit	Factor ^A	Units of Measurement ^B
Resistivity	ρ	$\Omega \cdot m$	10^2	$\Omega \cdot cm$
Charge carrier concentration	n, p	m^{-3}	10^{-6}	cm^{-3}
Charge	e, q	C	1	C
Drift mobility, Hall mobility	μ, μ_H	$m^2 \cdot V^{-1} \cdot s^{-1}$	10^4	$cm^2 \cdot V^{-1} \cdot s^{-1}$
Hall coefficient	R_H	$m^3 \cdot C^{-1}$	10^6	$cm^3 \cdot C^{-1}$
Electric field	E	$V \cdot m^{-1}$	10^{-2}	$V \cdot cm^{-1}$
Magnetic flux density	B	T	10^4	gauss
Current density	J	$A \cdot m^{-2}$	10^{-4}	$A \cdot cm^{-2}$
Length	L, t, w, d a, b, c	m	10^2	cm
Potential difference	V	V	1	V

^AThe factors relate SI units to the units of measurement as in the following example:

$$1 \Omega \cdot m = 10^2 \Omega \cdot cm$$

^BThis system is not a consistent set of units. In order to obtain a consistent set, the magnetic flux density must be expressed in $V \cdot s \cdot cm^{-2}$. The proper conversion factor is:

$$1 \cdot V \cdot s \cdot cm^{-2} = 10^8 \text{ gauss}$$

magnetic field with respect to the crystal axes (Appendix, Note X1.1). Errors can result if the magnetic field is not within the low-field limit (Appendix, Note X1.1).

5.1.10 Spurious voltages, which may occur in the measuring circuit, for example, thermal voltages, can be detected by measuring the voltage across the specimen with no current flowing or with the voltage leads shorted at the sample position. If there is a measurable voltage, the measuring circuit should be checked carefully and modified so that these effects are eliminated.

5.1.11 An erroneous Hall coefficient will be measured if the current and transverse electric field axes are not precisely perpendicular to the magnetic flux. The Hall coefficient will be at an extremum with respect to rotation if the specimen is properly positioned (see 7.4.4 or 13.4.4).

5.2 In addition to these interferences the following must be noted for van der Pauw specimens.

5.2.1 Errors may result in voltage measurements due to contacts of finite size. Some of these errors are discussed in references (1, 5, 6).

5.2.2 Errors may be introduced if the contacts are not placed on the specimen periphery (7).

5.3 In addition to the interferences described in 5.1, the following must be noted for parallelepiped and bridge-type specimens.

5.3.1 It is essential that in the case of parallelepiped or bridge-type specimens the Hall-coefficient measurements be made on side contacts far enough removed from the end contacts that shorting effects can be neglected (2, 3). The specimen geometries described in 15.3.1 and 15.3.2 are designed so that the reduction in Hall voltage due to this shorting effect is less than 1 %.

TEST METHOD A—FOR VAN DER PAUW SPECIMENS

6. Summary of Test Method

6.1 In this test method, specifications for a van der Pauw (1) test specimen and procedures for testing it are covered. A procedure is described for determining resistivity and Hall coefficient using direct current techniques. The Hall mobility is calculated from the measured values.

7. Apparatus

7.1 *For Measurement of Specimen Thickness*—Micrometer, dial gage, microscope (with small depth of field and calibrated vertical-axis adjustment), or calibrated electronic thickness gage capable of measuring the specimen thickness to ± 1 %.

7.2 *Magnet*—A calibrated magnet capable of providing a magnetic flux density uniform to ± 1.0 % over the area in which the test specimen is to be located. It must be possible to reverse the direction of the magnetic flux (either electrically or by rotation of the magnet) or to rotate the test specimen 180° about its axis parallel to the current flow. Apparatus, such as an auxiliary Hall probe or nuclear magnetic resonance system, should be available for measuring the flux density to an accuracy of ± 1.0 % at the specimen position. If an electromagnet is used, provision must be made for monitoring the flux density during the measurements. Flux densities between 1000

and 10 000 gauss are frequently used; conditions governing the choice of flux density are discussed more fully elsewhere (2, 3, 4).

7.3 Instrumentation:

7.3.1 *Current Source*, capable of maintaining current through the specimen constant to ± 0.5 % during the measurement. This may consist either of a power supply or a battery, in series with a resistance greater than $200 \times$ the total specimen resistance (including contact resistance). The current source is accurate to ± 0.5 % on all ranges used in the measurement. The magnitude of current required is less than that associated with an electric field of $1 \text{ V}\cdot\text{cm}^{-1}$ in the specimen.

7.3.2 *Electrometer or Voltmeter*, with which voltage measurements can be made to an accuracy of ± 0.5 %. The current drawn by the measuring instrument during the resistivity and Hall voltage measurements shall be less than 0.1 % of the specimen current, that is, the input resistance of the electrometer (or voltmeter) must be $1000 \times$ greater than the resistance of the specimen.

7.3.3 *Switching Facilities*, used for reversal of current flow and for connecting in turn the required pairs of potential leads to the voltage-measuring device.

7.3.3.1 *Representative Circuit*, used for accomplishing the required switching is shown in Fig. 1.

7.3.3.2 *Unity-Gain Amplifiers*, used for high-resistivity semiconductors, with input impedance greater than $1000 \times$ the specimen resistance are located as close to the specimen as possible to minimize current leakage and circuit time-constants (8, 9). Triaxial cable is used between the specimen and the amplifiers with the guard shield driven by the respective amplifier output. This minimizes current leakage in the cabling. The current leakage through the insulation must be less than 0.1 % of the specimen current. Current leakage in the specimen holder must be prevented by utilizing a suitable high-resistivity insulator such as boron nitride or beryllium oxide.

7.3.3.3 *Representative Circuit*, used for measuring high-resistance specimens is shown in Fig. 2. Sixteen single-pole, single-throw, normally open, guarded reed relays are used to connect the current source and differential voltmeter to the appropriate specimen points. The relay closures necessary to accomplish the same switching achieved in the circuit of Fig. 1 are listed in the table of Fig. 2.

7.3.4 *Transistor Curve Tracer*, can be used for checking the linearity of contacts to low-resistivity material.

7.3.5 All instruments must be maintained within their specifications through periodic calibrations.

7.4 Specimen Holder:

7.4.1 *Container*, if low-temperature measurements are required, of such dimensions that it will enclose the specimen holder (7.4.3) and fit between the magnetic pole pieces. A glass or metal dewar or a foamed polystyrene boat is suitable.

7.4.2 *Temperature Detector*, located in close proximity to the test specimen and associated instruments for monitoring temperature to an accuracy of $\pm 1^\circ\text{C}$ during the measurement. This may include, for example, a thermocouple, a platinum resistance thermometer, or a suitable thermistor.

7.4.3 *Opaque Container*, used to hold the specimen in

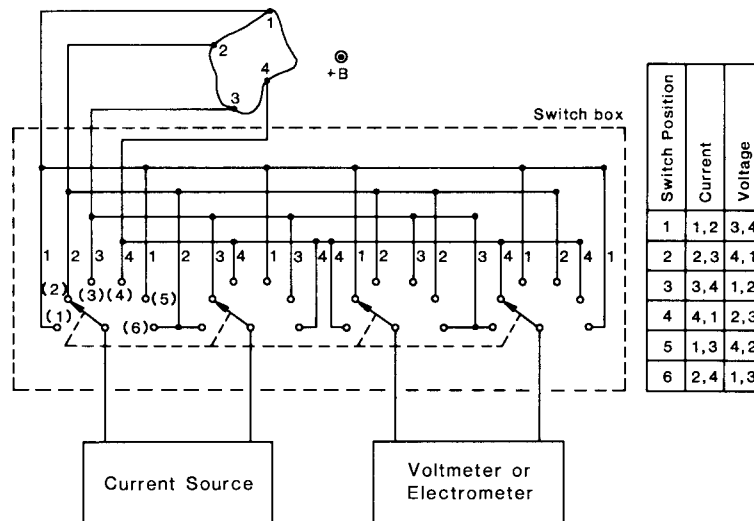
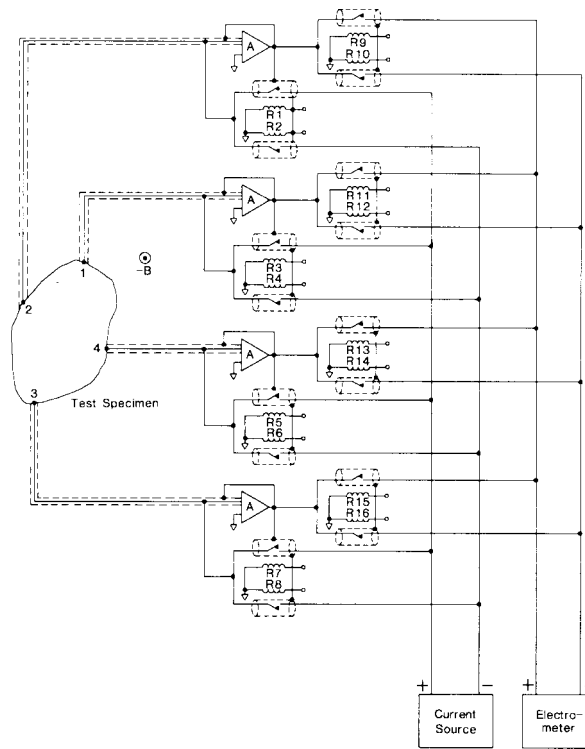

FIG. 1 Representative Manual Test Circuit for Measuring van der Pauw Specimens



NOTE 1—A—Unity gain amplifier

NOTE 2—R1-R16—Reed relays

Position	1	2	3	4	5	6
Switches	2, 3	1, 4	1, 8	2, 7	6, 7	5, 8
Closed	14, 15	14, 15	12, 13	12, 13	10, 11	10, 11
Current	1, 2	2, 1	2, 3	3, 2	3, 4	4, 3
Voltage	3, 4	3, 4	4, 1	4, 1	1, 2	1, 2

FIG. 2 Representative Test Circuit for Measuring High-Resistivity van der Pauw Specimens

position, to maintain an isothermal region around the specimen, and to shield the specimen from light and, in the case of low-temperature measurements, from room-temperature radiation. The mounting must be arranged so that mechanical stress on the specimen does not result from differential expansion

when measurements are made at temperatures different from room temperature. If liquids, such as boiling nitrogen, are used to establish low temperatures, the liquid may be allowed to enter the specimen container directly through ports that are suitably shielded against the entry of light.

7.4.4 If a metal dewar or specimen holder is used, it must be constructed of nonmagnetic materials such that the value of magnetic flux density at the specimen position will not be altered more than $\pm 1\%$ by its presence.

7.4.5 To orient the specimen perpendicular to the magnetic field it is desirable to employ both geometrical and electrical tests. Sign conventions are defined in Fig. 3.

7.4.5.1 The specimen holder can usually be visually aligned parallel with the flat faces of the magnet along the long axis (usually the vertical axis) of the specimen holder in a satisfactory manner. Care should be taken that the specimen is mounted within the container so that the flat faces are parallel with an external portion of the specimen holder.

7.4.5.2 Because the dimensions are much shorter in the direction perpendicular to the long axis, electrical orientation is preferred. This is most conveniently performed by rotating the specimen with respect to the magnetic flux and measuring the transverse voltage as a function of angle between the magnetic flux and a reference mark on the specimen holder over a range a few degrees on each side of the nominal perpendicular position. The correct position is that where the average Hall voltage is a maximum or, in some cases where orientation dependent effects are encountered, a minimum.

7.4.5.3 A more accurate method of electrical positioning involves rotation of the specimen with respect to the magnetic flux as in 7.4.5.2, but a few degrees around both positions approximately 90° away from the nominal perpendicular position. The correct angular position for the specimen during Hall-effect measurements is midway between the two points (about 180° apart) where the average transverse voltage is zero.

8. Reagents and Materials (See Section 9)

8.1 *Purity of Reagents*—All chemicals for which such specifications exist shall conform to SEMI Specifications C 1. Reagents for which SEMI specifications have not been developed shall conform to the specifications of the Committee on

Analytical Reagents of the American Chemical Society.⁷ Other grades may be used provided it is first ascertained that the reagent is sufficiently pure to permit its use without lessening the accuracy of the determination.

8.2 *Purity of Water*—When water is used it is either distilled water or deionized water having a resistivity greater than $2\text{ M}\Omega\text{-cm}$ at 25°C as determined by the Non-Referee Tests of Test Methods D 1125.

9. Test Specimen Requirements

9.1 Regardless of the specimen preparation process used, high-purity reagents and water are required.

9.2 *Crystal Perfection*—The test specimen is a single crystal.

NOTE 2—The procedure for revealing polycrystalline regions in silicon is given in Test Method F 47.

NOTE 3—The crystallographic orientation of the slice may be determined if desired, using either the X-ray or optical techniques of Method F 26.

9.3 *Specimen Shape*—The thickness shall be uniform to $\pm 1\%$. The minimum thickness is governed by the availability of apparatus which is capable of measuring the thickness to a precision of $\pm 1\%$. The test specimen shape can be formed by cleaving, machining, or photolithography. Machining techniques such as ultrasonic cutting, abrasive cutting, or sawing may be employed as required. Representative photolithographically defined test patterns are described in (10, 11, 12).

9.3.1 Although the specimen may be of arbitrary shape, one of the symmetrical configurations of Fig. 4 is recommended. The specimen must be completely free of (geometrical) holes. The recommended ratio of peripheral length of the specimen, L_p , to thickness of the specimen, t , is as follows:

$$L_p \geq 15t$$

Recommended thickness is less than or equal to 0.1 cm. This specimen shape can produce erroneous results when used on anisotropic materials (see 5.1.9 and Note X1.1).

9.4 Maintain the contact dimensions as small as possible relative to the peripheral length of the specimen. If possible, place the contacts on the specimen edge. Use line or dot contacts with a maximum dimension along the peripheral length, L_p , no greater than $0.05 L_p$. If the contacts must be placed on one of the two flat faces of the specimen that are separated by the dimension, t , make them as small as possible and locate them as close as possible to the edge (see 5.2.1 and 5.2.2).

10. Measurement Procedure

10.1 *Thickness Measurement*—Measure the specimen thickness (9.3) with a precision of $\pm 1\%$.

10.2 *Contact Evaluation*—Verify that all combinations of contact pairs in both polarities have linear current-voltage characteristics, without noticeable curvature, at the measurement temperature about the actual value of current to be used.

⁷ "Reagent Chemicals, American Chemical Society Specifications," Am. Chemical Soc., Washington, DC. For suggestions on the testing of reagents not listed by the American Chemical Society, see "Reagent Chemicals and Standards," by Joseph Rosin, D. Van Nostrand Co., Inc., New York, NY, and the "United States Pharmacopeia."

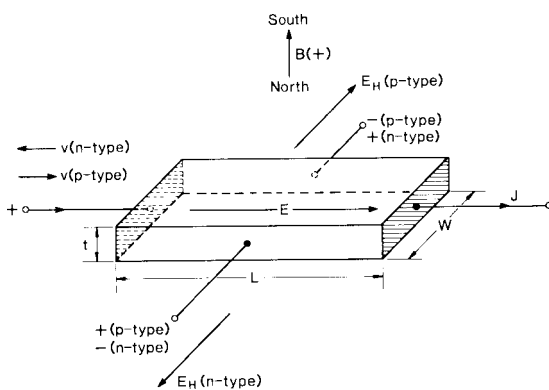

NOTE 1—The carrier velocity, V , for electrons and holes is in opposite directions as indicated.

FIG. 3 Hall-Effect Sign Conventions

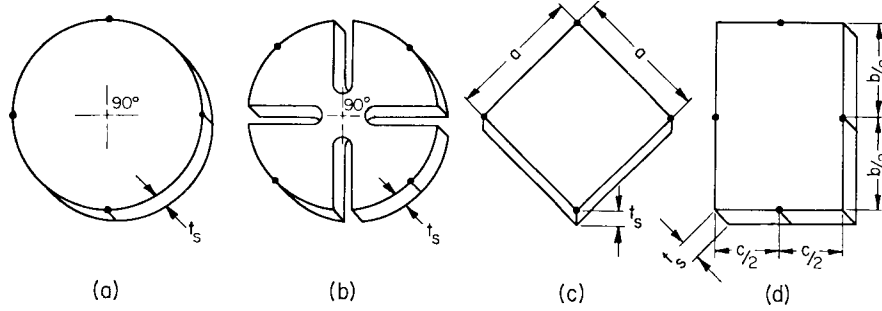

NOTE 1—Contact positions are indicated schematically by the small dots.

FIG. 4 Typical Symmetrical van der Pauw Specimens

10.3 *Specimen Placement*—Place the clean and contacted specimen in its container (7.4.3). If a permanent magnet is used to provide the flux, keep the magnet and the specimen separate during the measurement of resistivity. If possible, move the magnet without disturbing the specimen and its holder, so as to minimize the possibility of a change of temperature which must remain within the $\pm 1^\circ\text{C}$ tolerance between the resistivity and Hall-effect measurements. If an electromagnet is used, be certain that the residual flux density is small enough not to affect the resistivity measurement.

10.4 *Resistivity Measurement*—Measure the temperature of the specimen. Set the current magnitude, I , to the desired value (see 5.1.2). Measure the voltages $V_{21,34}$, $V_{12,34}$, $V_{32,41}$, $V_{23,41}$, $V_{43,12}$, $V_{34,12}$, $V_{14,23}$, and $V_{41,23}$ (Note 4). Remeasure the specimen temperature to check the temperature stability. If the second measurement of the temperature differs from the first by more than 1°C , allow the temperature to stabilize further, and then repeat the procedure of 10.4.

NOTE 4—The notation to be used, $V_{AB,CD}$, refers to the potential difference $V_C - V_D$ measured between Contacts C and D when current enters Contact A and exits Contact B . Both the sign and magnitude of all voltages must be determined and recorded. For van der Pauw specimens, the contacts are labeled consecutively in counter-clockwise order around the specimen periphery. Similarly the resistance $R_{AB,CD}$ is defined as the ratio of the voltage $V_C - V_D$ divided by the current directed into Contact A and out of Contact B .

10.5 *Hall-Coefficient Measurement*—Position the specimen between the magnet-pole pieces so that the magnetic flux is perpendicular to the two flat faces of the specimen which are separated by the dimension, t , (7.4.5). If an electromagnet is used to provide the flux, follow the appropriate procedure in 10.5.1. If a permanent magnet of known flux density is used, omit the adjustment and measurement of flux density.

10.5.1 In high-mobility materials such as lightly doped n -type gallium arsenide, the proportionality factor, r , (see Appendix X1) varies with the applied magnetic field. For the purposes of interlaboratory comparison, users should therefore use a field of 5 gauss (0.5 T) in the absence of other information. This effect is not expected to be significant for dopant density above 10^{17} cm^{-3} in n -type gallium arsenide.

10.5.2 Measure the temperature of the specimen. Turn on the magnetic flux and adjust it to the desired positive value of magnetic flux density. Measure the magnetic flux density. Measure the voltages $V_{31,42}(+B)$, $V_{13,42}(+B)$, $V_{42,13}(+B)$, and $V_{24,13}(+B)$ (Note 4 and Note 5). Remeasure the value of

the magnetic flux density in order to check the stability of the magnet. If the second value of magnetic flux density differs from the first by more than 1 %, make the necessary changes, and repeat the procedure until the specified stability is achieved. Rotate the specimen 180° or reverse the magnetic flux, and adjust it to the same magnitude ($\pm 1\%$) of magnetic flux density. Measure the voltages $V_{24,13}(-B)$, $V_{42,13}(-B)$, $V_{13,42}(-B)$, and $V_{31,42}(-B)$ (Note 4 and Note 5). Measure the temperature and magnetic flux density and check the stability as before.

NOTE 5—The parenthetical symbols (+B) and (-B) refer to oppositely applied magnetic fields where positive field is defined in Fig. 3.

10.6 *Cautions*—See Section 5 for discussion of spurious results.

11. Calculations

11.1 *Resistivity*—Calculate the sample resistivity from the data of 10.4. Two values of resistivity, ρ_A and ρ_B , are obtained as follows (Note 4):

$$\rho_A = \frac{1.1331 f_A t}{I} [V_{21,34} - V_{12,34} + V_{32,41} - V_{23,41}] \quad (1)$$

and

$$\rho_B = \frac{1.1331 f_B t}{I} [V_{43,12} - V_{34,12} + V_{14,23} - V_{41,23}] \Omega\text{-cm} \quad (2)$$

where the constant $1.1331 \sim \pi/4 \ln(2)$, the units of the voltages are in volts, the specimen thickness, t , is in centimetres, the current magnitude, I , is in amperes, and the geometrical factor f_A or f_B is a function of the resistance ratio, Q_A or Q_B , respectively:

$$Q_A = \frac{R_{21,34} - R_{12,34}}{R_{32,41} - R_{23,41}} = \frac{V_{21,34} - V_{12,34}}{V_{32,41} - V_{23,41}} \quad (3)$$

and

$$Q_B = \frac{R_{43,12} - R_{34,12}}{R_{14,23} - R_{41,23}} = \frac{V_{43,12} - V_{34,12}}{V_{14,23} - V_{41,23}} \quad (4)$$

The relationship between the factor f and Q is written explicitly and graphed in Fig. 5. If Q is less than one, take its reciprocal, and find the value of f for this number. If ρ_A is not equal to ρ_B within $\pm 10\%$, the specimen is inhomogeneous and a more uniform specimen is required. Calculate the average resistivity ρ_{av} as follows,

$$\rho_{av} = \frac{\rho_A + \rho_B}{2} \Omega\text{-cm} \quad (5)$$

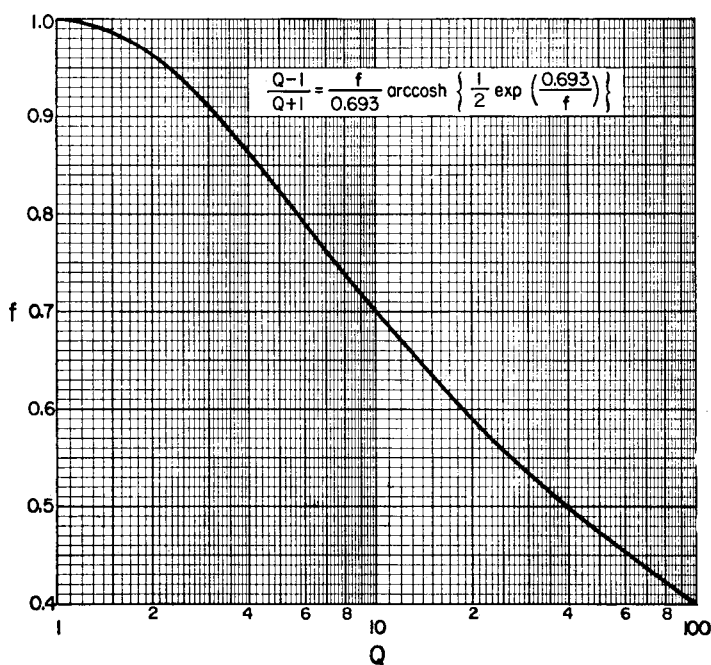

FIG. 5 The Factor *f* Plotted as a Function of *Q*

11.2 *Hall Coefficient*—Calculate the Hall coefficient from the data of 10.5. Two values of Hall coefficient, R_{HC} and R_{HD} , are obtained as follows (Note 4 and Note 5):

$$R_{HC} = \frac{2.50 \times 10^7 t}{BI} [V_{31,42}(+B) - V_{13,42}(+B) + V_{13,42}(-B) - V_{31,42}(-B)] \quad (6)$$

and

$$R_{HD} = \frac{2.50 \times 10^7 t}{BI} [V_{42,13}(+B) - V_{24,13}(+B) + V_{24,13}(-B) - V_{42,13}(-B)] \text{cm}^3 \cdot \text{C}^{-3} \quad (7)$$

If R_{HC} is not within $\pm 10\%$ of R_{HD} , the specimen is undesirably inhomogeneous and a more uniform specimen is required. Calculate the average Hall-coefficient R_{Hav} as follows:

$$R_{Hav} = \frac{R_{HC} + R_{HD}}{2} \text{cm}^3 \cdot \text{C}^{-1} \quad (8)$$

11.3 *Hall Mobility*—Calculate the Hall mobility,

$$\mu_H \equiv \frac{|R_{Hav}|}{\rho_{av}} \text{cm} \cdot \text{V}^{-1} \cdot \text{s}^{-1} \quad (9)$$

11.4 If this procedure is to be used to obtain carrier density, users should use a value of proportionality factor, r , of 1.0 in the absence of other information (see Appendix 1.3.2).

TEST METHOD B—FOR PARALLELEPIPED OR BRIDGE-TYPE SPECIMENS

12. Summary of Test Method

12.1 In this test method, specifications for rectangular parallelepiped and bridge-type specimens and procedures for testing these structures are covered. Procedures are described for determining resistivity and Hall coefficient using direct current techniques. The Hall mobility is calculated from the measured values.

NOTE 6—This test method for measuring resistivity is essentially equivalent to the two-probe measurement of Test Methods F 43, with the exception that in the present method the potential probes may be soldered, alloyed, or otherwise attached to the semiconductor specimen.

13. Apparatus

13.1 *For Measurement of Specimen Geometry:*

13.1.1 *Micrometer, Dial Gage, Microscope (with small depth of field and calibrated vertical-axis adjustment), or Calibrated Electronic Thickness gage*, capable of measuring the specimen thickness to $\pm 1\%$.

13.1.2 *Microscope*, with crosshair and calibrated mechanical stage, capable of measuring the specimen length and width to $\pm 1\%$.

13.2 *Magnet*—A calibrated magnet capable of providing a magnetic flux density uniform to $\pm 1.0\%$ over the area in which the test specimen is to be located. It must be possible to reverse the direction of the magnetic flux (either electrically or by rotation of the magnet) or to rotate the test specimen 180° about its axis parallel to the current flow. Apparatus, such as an auxiliary Hall probe or nuclear magnetic resonance system, should be available for measuring the flux density to an accuracy of $\pm 1.0\%$ at the specimen position. If an electromagnet is used, provision must be made for monitoring the flux density during the measurements. Flux densities between 1000 and 10 000 gauss are frequently used; conditions governing the choice of flux density are discussed more fully in Refs (2, 3, 4).

13.3 *Instrumentation:*

13.3.1 *Current Source*, capable of maintaining current through the specimen constant to $\pm 0.5\%$ during the measurement. This may consist either of a power supply or a battery, in series with a resistance greater than $200 \times$ the total specimen resistance (including contact resistance). The current source is accurate to $\pm 0.5\%$ on all ranges used in the measurement. The magnitude of current required is less than that associated with an electric field of $1 \text{ V} \cdot \text{cm}^{-1}$ in the specimen.

13.3.2 An electrometer or voltmeter with which voltage measurements can be made to an accuracy of $\pm 0.5\%$. The current drawn by the measuring instrument during the resistivity and Hall voltage measurements shall be less than 0.1% of the specimen current, that is, the input resistance of the electrometer (or voltmeter) must be $1000 \times$ greater than the resistance of the specimen.

13.3.3 Switching facilities for reversal of current flow and for connecting in turn the required pairs of potential leads to the voltage-measuring device.

13.3.3.1 A representative circuit for accomplishing the required switching is shown in Fig. 6.

13.3.3.2 Unity-Gain Amplifiers, for high-resistivity semiconductors, with input impedance greater than $1000 \times$ the specimen resistance are located as close to the specimen as possible to minimize current leakage and circuit time-constants (8, 9). Triaxial Cable, used between the specimen and the amplifiers with the guard shield driven by the respective amplifier output. This minimizes current leakage in the cabling. The current leakage through the insulation must be less than 0.1% of the specimen current. Current leakage in the specimen holder must be prevented by utilizing a suitable high-resistivity insulator such as boron nitride or beryllium oxide.

13.3.4 Transistor Curve Tracer, can be used for checking the linearity of contacts to low-resistivity material.

13.3.5 All instruments must be maintained within their specifications through periodic calibrations.

13.4 Specimen Holder:

13.4.1 A container of such dimensions that it will enclose the specimen holder (13.4.3) and fit between the magnetic pole pieces. A glass or metal dewar or a foamed polystyrene boat is suitable.

13.4.2 A temperature detector located in close proximity to the test specimen and associated instruments for monitoring temperature to an accuracy of $\pm 1^\circ\text{C}$ during the measurement. This may include, for example, a thermocouple, a platinum resistance thermometer, or a suitable thermistor.

13.4.3 An opaque container to hold the specimen in position, to maintain an isothermal region around the specimen,

and to shield the specimen from light and, in the case of low-temperature measurements, from room-temperature radiation. The mounting must be arranged so that mechanical stress on the specimen does not result from differential expansion when measurements are made at temperatures different from room temperature. If liquids, such as boiling nitrogen, are used to establish low temperatures, the liquid may be allowed to enter the specimen container directly through ports that are suitably shielded against the entry of light.

13.4.4 If a metal dewar or specimen holder is used, it must be constructed of nonmagnetic materials such that the value of magnetic flux density at the specimen position will not be altered more than $\pm 1\%$ by its presence.

13.4.5 To orient the specimen perpendicular to the magnetic field it is desirable to employ both geometrical and electrical tests. Sign conventions are defined in Fig. 3.

13.4.5.1 The specimen holder can usually be visually aligned parallel with the flat faces of the magnet along the long axis (usually the vertical axis) of the specimen holder in a satisfactory manner. Care should be taken that the specimen is mounted within the container so that the flat faces are parallel with an external portion of the specimen holder.

13.4.5.2 Because the dimensions are much shorter in the direction perpendicular to the long axis, electrical orientation is preferred. This is most conveniently performed by rotating the specimen with respect to the magnetic flux and measuring the transverse voltage as a function of angle between the magnetic flux and a reference mark on the specimen holder over a range a few degrees on each side of the nominal perpendicular position. The correct position is that where the average Hall voltage is a maximum or, in some cases where orientation dependent effects are encountered, a minimum.

13.4.5.3 A more accurate method of electrical positioning involves rotation of the specimen with respect to the magnetic flux as in 13.4.5.2, but a few degrees around both positions approximately 90° away from the nominal perpendicular position. The correct angular position for the specimen during Hall-effect measurements is midway between the two points (about 180° apart) where the average transverse voltage is zero.

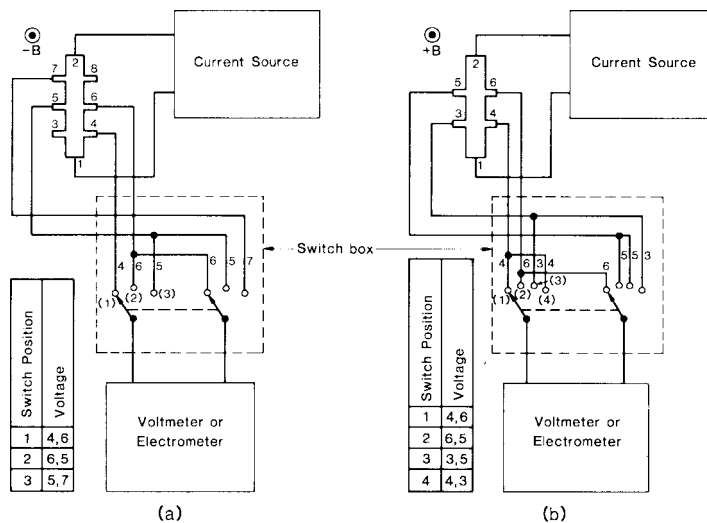

NOTE 1—(a) Eight-contact specimen (b) Six-contact specimen

FIG. 6 Representative Test Circuits for Measuring Bridge-Type and Parallelepiped Specimens

14. Reagents and Materials (See Section 15)

14.1 *Purity of Reagents*—All chemicals for which such specifications exist shall conform to SEMI Specifications C 1. Reagents for which SEMI specifications have not been developed shall conform to the specifications of the Committee on Analytical Reagents of the American Chemical Society.⁷ Other grades may be used provided it is first ascertained that the reagent is sufficiently pure to permit its use without lessening the accuracy of the determination.

14.1.1 *Purity of Water*—When water is used it is either distilled water or deionized water having a resistivity greater than 2 MΩ·cm at 25°C as determined by the Non-Referee Tests of Test Method D 1125.

15. Test Specimen Requirements

15.1 Regardless of the specimen preparation process used, high-purity reagents and water are required.

15.2 *Crystal Perfection*—The test specimen is a single crystal.

NOTE 7—The procedure for revealing polycrystalline regions in silicon is given in Test Method F 47.

NOTE 8—The crystallographic orientation of the slice may be determined if desired, using either the X-ray or optical techniques of Test Method F 26.

15.3 *Specimen Shape*—The thickness shall be uniform to ± 1 % and shall not exceed 0.10 cm. The minimum thickness is governed by the availability of apparatus which is capable of measuring the thickness to a precision of ±1 %. Machine or cleave the test specimen into one of the forms shown in Fig. 7 and Fig. 8, respectively. Machining techniques such as ultrasonic cutting, abrasive cutting, or sawing are employed as required.

15.3.1 *Parallelepiped Specimen*—The total length of the specimen shall be between 1.0 and 1.5 cm. The sides must be perpendicular to the specimen surface to within ±0.5°. If possible, the length to width ratio should be greater than 5, but in no case shall it be less than 4. The sample configuration is shown in Fig. 7(a).

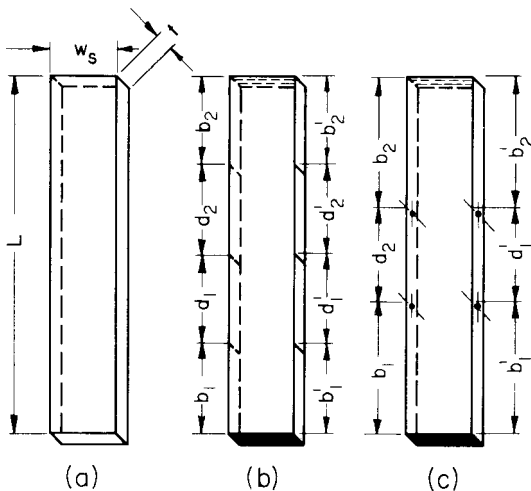

NOTE 1—Current contacts cover the entire end of the specimen. Potential contacts may be either lines as in (b) or dots as in (c).

FIG. 7 Typical Parallelepiped Specimens

15.3.2 *Bridge-Type Specimen*—Contact positions on this type of specimen are determined by the configuration of the die used in cutting it. The dies must enable sample dimensions to be held to a tolerance of 1 %. Any of the contact configurations shown in Fig. 8 are recommended. In some configurations the protruding side arms of the specimen are enlarged in cross section to facilitate the application of contacts. The ends of the specimen may also be enlarged in order to allow the use of contacts applied to the top surface, as in the case of evaporated contacts. See Fig. 8(c) and Fig. 8(d). The enlarged portions of the ends shall not be included in the total specimen length specified above.

15.3.3 *Eight-Contact Specimen*—The geometry of the specimen is defined below, see Fig. 8(a) and 8(c):

$$\begin{aligned}
 L &\geq 4w \\
 w &\geq 3a \\
 b_1, b_2 &\geq w \\
 t &\leq 0.1 \text{ cm} \\
 c &\geq 0.1 \text{ cm} \\
 1.0 \text{ cm} &\leq L \leq 1.5 \text{ cm} \\
 b_1 &= b_1' \pm 0.005 \text{ cm} \\
 b_2 &= b_2' \pm 0.005 \text{ cm} \\
 d_1 &= d_1' \pm 0.005 \text{ cm} \\
 d_2 &= d_2' \pm 0.005 \text{ cm} \\
 b_1 + d_1 &= (1/2)L + 0.005 \text{ cm} \\
 b_1' = d_1' &= (1/2)L \pm 0.005 \text{ cm} \\
 b_1 &\approx b_2, \quad d_1 \approx d_2
 \end{aligned}$$

15.3.4 *Six-Contact Specimen*—The geometry of the specimen is defined as follows, see Fig. 8(b) and 8(d):

$$\begin{aligned}
 L &\geq 5w \\
 w &\geq 3a \\
 b_1, b_2 &\geq 2w \\
 t &\leq 0.1 \text{ cm} \\
 c &\geq 0.1 \text{ cm} \\
 1.0 \text{ cm} &\leq L \leq 1.5 \text{ cm} \\
 b_1 &= b_1' \pm 0.005 \text{ cm} \\
 b_2 &= b_2' \pm 0.005 \text{ cm} \\
 d_2 &= d_1' \pm 0.005 \text{ cm} \\
 b_1 &\approx b_2
 \end{aligned}$$

15.4 Contact Requirements:

15.4.1 *Parallelepiped Specimens*—The two ends of the specimen must be completely covered with current contacts. Make the contact interface with the specimen for the other (voltage measurement) contacts less than 0.02 cm in width. If six potential contacts are employed, position them as shown in Fig. 7(b). If four voltage contacts are employed, position them as shown in Fig. 7(c).

15.4.2 *Bridge-Type Specimens Without Expanded End Contacts*—Completely cover the ends of the specimen with current contacts.

15.4.3 *Bridge-Type Specimens with Expanded Side and End Contacts*—Place the contacts on appropriate locations on one of the two flat faces of the specimen which are separated by the dimension, *t* (see the shaded areas in Fig. 8(c) and (d)).

16. Measurement Procedure

16.1 *Dimension Measurement*—The specimen length, width, and thickness must be measured with a precision of ±1 % (13.1).

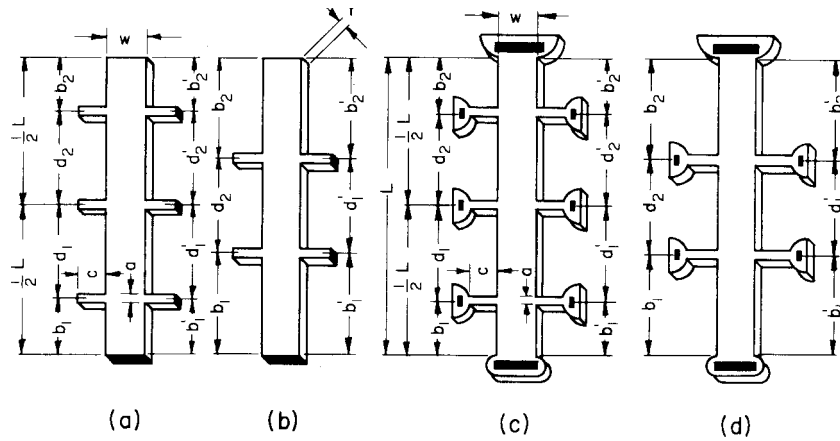

FIG. 8 Typical Bridge-Type Specimens

16.2 *Contact Evaluation*—Verify that all combinations of contact pairs in both polarities have linear current-voltage characteristics, without noticeable curvature, at the measurement temperature about the actual value of current to be used.

16.3 *Specimen Placement*—Place the clean and contacted specimen in its container (13.4.3). If a permanent magnet is used to provide the flux, keep the magnet and the specimen separate during the measurement of resistivity. If possible, move the magnet without disturbing the specimen and its holder, so as to minimize the possibility of a change of temperature which must remain within the $\pm 1^\circ\text{C}$ tolerance between the resistivity and Hall-effect measurements. If an electromagnet is used, be certain that the residual flux density is small enough not to affect the resistivity measurement.

16.4 *Resistivity Measurement:*

16.4.1 *Eight-Contact Specimen*—Measure the specimen temperature. With no magnetic flux, measure the voltages $V_{12,46}$ and $V_{12,57}$ (Note 9). Reverse the current and measure $V_{21,46}$ and $V_{21,57}$. Remeasure the specimen temperature to check the temperature stability. If the second temperature measurement differs from the first by more than 1°C , allow the temperature to stabilize further, and then repeat the procedure of 16.4.1.

NOTE 9—The notation to be used, $V_{AB,CD}$, refers to the potential difference $V_C - V_D$ measured between Contact C and D when current enters Contact A and exits Contact B. Both the sign and magnitude of all voltages must be determined and recorded. For parallelepiped and bridge-type specimens the contacts are labeled in Fig. 6. Similarly the resistance $R_{AB,CD}$ is defined as the ratio of the voltage $V_C - V_D$ divided by the current directed into Contact A and out of Contact B.

16.4.2 *Six-Contact Specimen*—Measure the specimen temperature. With no magnetic flux, measure the voltages $V_{12,46}$ and $V_{12,35}$ (Note 9). Reverse the current and measure $V_{21,46}$ and $V_{21,35}$. Remeasure the specimen temperature to check the temperature stability. If the second temperature measurement differs from the first by more than 1°C , allow the temperature to stabilize further, and then repeat the procedure of 16.4.2.

16.5 *Hall-Coefficient Measurement:*

16.5.1 *Eight-Contact Specimen*—Measure the specimen temperature. Turn on the magnetic flux, and adjust it to the desired positive value of magnetic flux density. Measure the magnetic flux density. Measure the voltage $V_{12,65}(+B)$. Re-

verse the current and measure $V_{21,65}(+B)$ (Note 5 and Note 9). Remeasure the magnetic flux density to check the stability of the magnet. If the second value of magnetic flux density differs from the first by more than 1 %, make the necessary changes and repeat the procedure until the specified stability is achieved. Rotate the specimen 180° or reverse the magnetic flux and adjust it to the same magnitude ($\pm 1\%$) of magnetic flux density. Measure the magnetic flux density. Repeat the voltage measurements to obtain $V_{21,65}(-B)$. Reverse the current and repeat the measurements to obtain $V_{12,65}(-B)$. Verify the stability of the magnetic flux density and temperature as before.

NOTE 10—The parenthetical symbols (+B) and (-B) refer to oppositely applied magnetic fields where positive field is defined in Fig. 2.

16.5.2 *Six-Contact Specimen*—Measure the specimen temperature. Turn on the magnetic flux, and adjust it to the desired positive value of magnetic flux density. Measure the magnetic flux density. Measure the voltages $V_{12,65}(+B)$ and $V_{12,43}(+B)$ (Note 5 and Note 9). Reverse the current and measure $V_{21,65}(+B)$ and $V_{21,43}(+B)$. Remeasure the magnetic flux density to check the stability of the magnetic field. If the second value of magnetic flux density differs from the first by more than 1 %, make the necessary changes and repeat the procedure until the specified stability is achieved. Rotate the specimen 180° or reverse the magnetic field and adjust it to the same magnitude ($\pm 1\%$) of magnetic flux density. Measure the magnetic flux density. Repeat the voltage measurements to obtain $V_{21,65}(-B)$ and $V_{21,43}(-B)$. Reverse the current and repeat the measurements to obtain $V_{12,65}(-B)$ and $V_{12,43}(-B)$. Verify the stability of the magnetic field and temperature as before.

16.6 *Cautions*—See Section 5 for a discussion of spurious results.

17. *Calculations*

17.1 *Resistivity:*

17.1.1 *Eight-Contact Specimens*—Calculate the sample resistivity at the two positions on the specimens from the data of 16.4.1. The resistivity at one position (ρ_A) is given by (Note 9):

$$\rho_A = \frac{V_{12,46} - V_{21,46}}{2I} \frac{Wt}{d_1^2} \Omega \cdot \text{cm} \quad (10)$$

and the resistivity at the other position (ρ_B) is given by:

$$\rho_B = \frac{V_{12,57} - V_{21,57}}{2I} \frac{wt}{d_2} \Omega \cdot \text{cm} \quad (11)$$

where the units of the voltages are in volts, current is in amperes and w , t , d_1 , and d_2 are in centimetres.

17.1.2 *Six-Contact Specimens*—Computed from the data of 16.4.2 with ρ_A given by the equation of 17.1.1 and ρ_B given by (Note 9),

$$\rho_B = \frac{V_{12,35} - V_{21,35}}{2I} \frac{wt}{d_2} \Omega \cdot \text{cm} \quad (12)$$

17.1.3 If ρ_A and ρ_B are not equal within $\pm 10\%$, the specimen is undesirably inhomogeneous and a more uniform specimen is required. Calculate the average resistivity ρ_{av} ,

$$\rho_{av} = \frac{\rho_A + \rho_B}{2} \Omega \cdot \text{cm} \quad (13)$$

17.2 Hall Coefficient:

17.2.1 *Eight-Contact Specimen*—Calculate the Hall coefficient from the data of 16.5.1 (Note 5 and Note 9),

$$R_{HA} = 2.50 \times 10^7 \frac{t}{B} \quad (14)$$

$$\frac{V_{12,65}(+B) - V_{21,65}(+B) + V_{21,65}(-B) - V_{12,65}(-B)}{I} \text{ cm}^3 \cdot \text{C}^{-1}$$

where the units of the voltage are in volts, current is in amperes, t is in centimetres, and B is in gauss. R_{HA} will be negative for n -type material and positive for p -type material.

17.2.2 *Six-Contact Specimen*—Using the data of 16.5.2 calculate R_{HA} as in 17.2.1 and a second Hall coefficient R_{HB} as follows (Note 5 and Note 9),

$$R_{HB} = 2.50 \times 10^7 \frac{t}{B} \quad (15)$$

$$\frac{V_{12,43}(+B) - V_{21,43}(+B) + V_{21,43}(-B) - V_{12,43}(-B)}{I} \text{ cm}^3 \cdot \text{C}^{-1}$$

If R_{HA} and R_{HB} are not equal within $\pm 10\%$, the specimen is undesirably inhomogeneous and a more uniform specimen is required. When two values of Hall coefficient are available calculate the average Hall coefficient R_{Hav} as follows,

$$R_{Hav} = \frac{R_{HA} + R_{HB}}{2} \text{ cm}^3 \cdot \text{C}^{-1} \quad (16)$$

17.3 *Hall Mobility*—Calculate the Hall mobility with R_{Hav} given by R_{HA} for the case of an eight-contact specimen.

$$\mu_H = \frac{|R_{Hav}|}{\rho_{av}} \text{ cm}^2 \cdot \text{V}^{-1} \cdot \text{s}^{-1} \quad (17)$$

18. Report

18.1 For referee tests report the following information:

18.1.1 Identification of test specimen,

18.1.2 Test temperature,

18.1.3 Specimen shape used, orientation, and corresponding dimensions,

18.1.4 Magnitude and polarity of all voltages and magnetic-flux density, and

18.1.5 Calculated average resistivity, average Hall-coefficient (including sign), and Hall mobility.

19. Precision and Bias

19.1 When the Hall mobility of the same specimen is measured in several laboratories under the same conditions of temperature ($\pm 1^\circ\text{C}$) and magnetic-flux density ($\pm 10\%$) the precision, as defined in Practice E 177, expected when the method is used for measurements on germanium, silicon, and gallium arsenide with resistivity in the range from 0.01 to 10 $\Omega \cdot \text{cm}$ is $\pm 7\%$ (*R2S*). This estimate is based on results of a preliminary interlaboratory test in which five laboratories measured each of two specimens at two temperatures. For other materials, and outside this resistivity range, comparable precision is expected, but this has not yet been verified by round-robin tests.

19.2 A second interlaboratory test conducted on four gallium arsenide parallelepipeds (six-contacts) and four gallium arsenide clover-leaf specimens yielded the following pooled estimates (*R2S*) for interlaboratory precision: $\pm 16\%$, $\pm 26\%$, and $\pm 14\%$ for the resistivity, Hall coefficient, and Hall mobility of the parallelepipeds and $\pm 3.2\%$, $\pm 15\%$, and $\pm 12\%$ for the resistivity, Hall coefficient, and Hall mobility of the clover-leaves. Contacts were applied only once to the clover-leaf specimens; each of the eight participants used the same thickness in the calculations. Each of the five participants who measured the parallelepipeds also measured the appropriate dimensions of the parallelepiped specimens. The following were the pooled estimates (*R2S*) for precision: $\pm 4.6\%$, $\pm 2.6\%$, and $\pm 3.2\%$ for the thickness (~ 0.6 mm), width (~ 3 mm), and distance between contacts (~ 5 mm). One of the parallelepipeds fractured after the third measurement. In each group there were three n -type specimens (with resistivity in the range 0.001 to 0.3 $\Omega \cdot \text{cm}$ and carrier density $\sim 5 \times 10^{16}$ to $\sim 4 \times 10^{18} \text{ cm}^{-3}$) and one p -type specimen (with resistivity $\sim 0.007 \Omega \cdot \text{cm}$ and carrier density $\sim 1 \times 10^{19} \text{ cm}^{-3}$). Measurements were made at nominal laboratory temperatures and in a magnetic-flux density in the range 3 to 10 kgauss (0.3 to 1.0 T).

19.3 The precision values quoted were obtained using version F76 – 67T of the method. Another interlaboratory test of the method for gallium arsenide is underway.

20. Keywords

20.1 gallium arsenide; Hall coefficient; Hall data; Hall mobility; Hall resistivity; semiconductor; silicon; single crystal; van der Pauw

APPENDIX

(Nonmandatory Information)

X1. INTERPRETATION

X1.1 The interpretation of the results of these measurements in terms of semiconductor material parameters is often not straightforward. When more information is needed than is provided here, the reader is referred to the literature (2, 3, 4).

X1.2 The *resistivity* of a material is the ratio of the potential gradient parallel to the current in the material to the current density. For the purposes of this method, the resistivity shall always be determined for the case of zero magnetic flux.

X1.2.1 In extrinsic semiconductors with a single type of charge carrier the resistivity is related to the fundamental material properties as follows:

$$\rho = \frac{1}{e\mu n} \quad (\text{X1.1})$$

where:

ρ = resistivity,

e = magnitude of the electronic charge,

μ = magnitude of the mobility of the charge carrier (X1.5),
and

n = charge carrier density.

When both electrons and holes are present, the following equation applies:

$$\rho = \frac{1}{e(\mu_n n + \mu_p p)} \quad (\text{X1.2})$$

where n and p represent the electron and hole densities, respectively, and μ_n and μ_p represent the corresponding average electron and hole mobilities. Eq 2 is appropriate for intrinsic semiconductors (where the electron and hole concentrations are approximately equal).

X1.3 When mutually perpendicular electric and magnetic fields are impressed on an isotropic solid, the charge carriers are deflected in the third mutually perpendicular direction. If the current in this direction is constrained by the boundary of the solid (to be zero), a *transverse voltage* is developed to oppose the deflection of the charge carriers. The magnetic-field dependence of the transverse voltage has both an odd and an even component. The even component of transverse voltage is attributed to magnetoresistance and contact misalignment voltages. The odd component is by definition the *Hall voltage*, that is, the component of the transverse voltage which reverses sign with reversal of magnetic-field direction.

X1.4 The *Hall coefficient* is the ratio of the Hall electric field (due to the Hall voltage) to the product of the current density and the magnetic flux density (see Fig. 3) as follows:

$$R_H = \frac{E_H}{JB} \quad (\text{X1.3})$$

where:

R_H = Hall coefficient,

E_H = Hall electric field,

J = current density, and

B = magnetic flux density.

NOTE X1.1—The Hall coefficient is independent of crystal orientation provided the crystal structure is cubic and the measurements are performed at low-magnetic fields. For noncubic crystals, the orientation of the current and magnetic field directions must be chosen appropriately. The low-magnetic-field condition is given as follows:

$$(\mu B)^2 \ll 1$$

where the mobility, μ , is given in $\text{m}^2/\text{V}\cdot\text{s}$ and the magnetic flux density, B , is given in tesla. As an example, high-mobility n -type gallium arsenic with a mobility of $4000 \text{ cm}^2/\text{V}\cdot\text{s}$ measured in a field of 0.5 T (5 kgauss) gives a value $(\mu B)^2 = 0.04$ which should be low enough so as not to introduce significant field-dependent anisotropies into R_H .

X1.4.1 For n -type extrinsic semiconductors, in which the conduction is primarily by electrons, the Hall coefficient is negative; for p -type extrinsic semiconductors, in which the conduction is primarily by holes, it is positive. Conventions relating the signs of the various quantities are shown in Fig. 3.

X1.4.2 For extrinsic semiconductors at temperatures below the intrinsic region with conduction dominated by a single charge-carrier type, the Hall coefficient is related to the material properties as follows:

$$R_H = \frac{r}{nq} \quad (\text{X1.4})$$

where:

r = proportionality factor and

q = charge of the carrier ($-e$ for electrons and $+e$ for holes).

The proportionality factor, which is of the order of unity, depends on the details of the band structure, scattering mechanism or mechanisms, specimen temperature, magnetic-flux density, and (in some cases) specimen orientation (13). Detailed knowledge of r is required in order to determine accurately the charge-carrier density from the Hall coefficient measured in a specific instance. In many cases, such information is not known and r must be estimated. A summary of the available information is given separately (2, 3, 4, 14). When both electrons and holes are present in comparable quantities, the density of each type cannot be found from a single, low-field Hall-coefficient measurement, because the Hall-coefficient depends on the density and mobility of each carrier (2, 3, 4).

X1.4.3 In principle, the proportionality factor r can experimentally be made equal to unity by performing measurements in the "high-field region" where the product of the magnetic field and the mobility is much greater than one:

$$\mu B \gg 1$$

Unfortunately, this condition is only practical in special cases (15) due to the high-magnetic field required for most semiconductors at room temperature.

X1.5 The average *Hall mobility* is the ratio of the magnitude of the Hall coefficient to the resistivity; it is readily interpreted only in a system with carriers of one charge type.

X1.6 The *drift mobility* of a charge carrier is the ratio of the mean velocity of the carriers to the applied electric field. In a single carrier system, either *n*- or *p*-type, the drift mobility, μ is related to the average Hall mobility, μ_H by the proportionality factor *r*,

$$\mu_H = r\mu \quad (X1.5)$$

If *r* is known for the material being studied and the conditions of the measurement (2, 3, 4), it is possible to obtain an accurate value of drift mobility from measurements of the Hall coefficient and resistivity.

REFERENCES

- (1) van der Pauw, L. J., "A Method of Measuring Specific Resistivity and Hall Effect of Discs of Arbitrary Shape," *Philips Research Reports*, Vol 13, 1958, pp. 1–9.
- (2) Putley, E. H., *Hall Effect and Related Phenomena*, Butterworth & Co., Ltd., London, 1960.
- (3) Beer, A. C., *Galvanomagnetic Effects in Semiconductors*, Academic Press, Inc., New York, NY, 1963.
- (4) Stillman, G. E., Wolfe, C. M., and Dimmock, J. O., "Hall Coefficient Factor for Polar Mode Scattering in n-type GaAs," *Journal of Physics and Chemistry of Solids*, Vol 31, 1970, pp. 1119–1204.
- (5) Chwang, R., Smith, B. J., and Crowell, C. R., "Contact Size Effects on the van der Pauw Method for Resistivity and Hall Coefficient Measurement," *Solid-State Electronics*, Vol 17, 1974, pp. 1217–1227.
- (6) Versnel, W., "Analysis of the Greek Cross, a van der Pauw Structure with Finite Contacts," *Solid-State Electronics*, Vol 22, 1979, pp. 911–914.
- (7) Buehler, M. G., and Thurber, W. R., "Measurements of the Resistivity of a Thin Sample with a Square Four-Probe Array," *Solid-State Electronics*, Vol 20, 1977, pp. 403–406.
- (8) Hemenger, P. M., "Measurements of High Resistivity Semiconductors Using the van der Pauw Method," *Review Science Instruments*, Vol 44, 1973, pp. 698–700.
- (9) Look, D. C., and Farmer, J. W., "Automated, High Resistivity Hall Effect and Photoelectronic Apparatus," *Journal Physics E: Science Instruments*, Vol 14, 1981, pp. 472–477.
- (10) Johansson, N. G. E., Mayer, J. W., and Marsh, O. J., "Technique Used in Hall Effect Analysis of Ion Implanted Si and Ge," *Solid-State Electronics*, Vol 13, 1970, pp. 317–335.
- (11) Crossley, P. A., and Ham, W. E., "Use of Test Structures and Results of Electrical Tests for Silicon-on-Sapphire Integrated Circuit Processes," *Journal of Electronic Materials*, Vol 2, 1973, pp. 465–483.
- (12) Buehler, M. G., "Semiconductor Measurement Technology: Microelectronic Test Pattern NBS-3 for Evaluating the Resistivity-Dopant Density Relationship of Silicon," *NBS Special Publication 400-22* (May 1976).
- (13) Allgaier, R. S., "Some General Input-Output Rules Governing Hall Coefficient Behavior," *The Hall Effect and Its Applications*, ed. by C. L. Chien and C. R. Westgate, Plenum Press, New York, NY, 1980.
- (14) Szmulowicz, F., "Calculation of Optical- and Acoustic-Phonon-Limited Conductivity and Hall Mobilities for p-Type Silicon and Germanium," *Physical Review B*, Vol 28, 1983, pp. 5943–5963.
- (15) Mitchel, W. C., and Hemenger, P. M., "Temperature Dependence of the Hall Factor and the Conductivity Mobility in p-Type Silicon," *Journal of Applied Physics*, Vol 53, 1982, pp. 6880–6884.

The American Society for Testing and Materials takes no position respecting the validity of any patent rights asserted in connection with any item mentioned in this standard. Users of this standard are expressly advised that determination of the validity of any such patent rights, and the risk of infringement of such rights, are entirely their own responsibility.

This standard is subject to revision at any time by the responsible technical committee and must be reviewed every five years and if not revised, either reapproved or withdrawn. Your comments are invited either for revision of this standard or for additional standards and should be addressed to ASTM Headquarters. Your comments will receive careful consideration at a meeting of the responsible technical committee, which you may attend. If you feel that your comments have not received a fair hearing you should make your views known to the ASTM Committee on Standards, at the address shown below.

This standard is copyrighted by ASTM, 100 Barr Harbor Drive, PO Box C700, West Conshohocken, PA 19428-2959, United States. Individual reprints (single or multiple copies) of this standard may be obtained by contacting ASTM at the above address or at 610-832-9585 (phone), 610-832-9555 (fax), or service@astm.org (e-mail); or through the ASTM website (www.astm.org).