



Standard Test Methods for Specific Gravity of Water and Brine¹

This standard is issued under the fixed designation D 1429; the number immediately following the designation indicates the year of original adoption or, in the case of revision, the year of last revision. A number in parentheses indicates the year of last reapproval. A superscript epsilon (ε) indicates an editorial change since the last revision or reapproval.

1. Scope*

1.1 These test methods cover the determination of the specific gravity of water and brine free of separable oil, as follows:

	Sections
Test Method A—Pycnometer	7 to 11, 21
Test Method B—Balance	12 to 16, 21
Test Method C—Erlenmeyer Flask	17 to 21
Test Method D—Hydrometer	22 to 27

1.2 Test Methods A and B are applicable to clear waters or those containing only a moderate amount of particulate matter. Test Method B is preferred for samples of sea water or brines and is more sensitive than Test Method D which has the same general application. Test Method C is intended for samples of water containing mud or sludge.

1.3 It is the user's responsibility to ensure the validity of these test methods for waters of untested matrices.

1.4 The test method was tested at 22°C over a range, shown in Tables 1-4, of 1.0252 through 1.2299; all data were corrected to 15.6°C (60°F).

1.5 *This standard does not purport to address all of the safety concerns, if any, associated with its use. It is the responsibility of the user of this standard to establish appropriate safety and health practices and determine the applicability of regulatory limitations prior to use.*

2. Referenced Documents

2.1 ASTM Standards:

- D 1066 Practice for Sampling Steam²
- D 1129 Terminology Relating to Water²
- D 1193 Specification for Reagent Water²
- D 2777 Practice for Determination of Precision and Bias of Applicable Methods of Committee D19 on Water²
- D 3370 Practices for Sampling Water from Closed Conduits²
- D 5847 Practice for Writing Quality Control Specifications for Standard Test Methods for Water Analysis³

¹ These test methods are under the jurisdiction of ASTM Committee D19 on Water, and are the direct responsibility of Subcommittee D19.05 on Inorganic Constituents in Water.

Current edition approved Aug. 10, 2003. Published September 2003. Originally approved in 1956. Last previous edition approved in 1999 as D 1429 – 95 (1999).

² *Annual Book of ASTM Standards*, Vol 11.01.

³ *Annual Book of ASTM Standards*, Vol 11.02.

E 1 Specification for ASTM Thermometers⁴

3. Terminology

3.1 Definitions:

3.1.1 *brine*—water that contains dissolved matter at an approximate concentration of more than 30 000 mg/L.

3.1.2 For definitions of terms used in these test methods, refer to Terminology D 1129.

4. Significance and Use

4.1 Specific gravity is an important property of fluids being related to density and viscosity. Knowing the specific gravity will allow determination of a fluid's characteristics compared to a standard, usually water, at a specified temperature. This will allow the user to determine if the test fluid will be heavier or lighter than the standard fluid.

5. Reagents

5.1 *Purity of Water*—Unless otherwise indicated, reference to water shall be understood to mean reagent water conforming to Specification D 1193, Type I. Other reagent water types may be used provided it is first ascertained that the water is of sufficiently high purity to permit its use without adversely affecting the precision and bias of the test method. Type III water was specified at the time of round robin testing of this test method.

6. Sampling

6.1 Collect the samples in accordance with Practices D 3370 and Practice D 1066.

6.2 In view of the lack of a standard test method for sampling mud or sludge, no instructions are given for sampling this type of material.

TEST METHOD A—PYCNOMETER

7. Summary of Test Method

7.1 The sample is introduced into a pycnometer, stabilized at the desired temperature, and weighed. The specific gravity is calculated from this weight and the previously determined weight of reagent water that is required to fill the pycnometer at the same temperature.

⁴ *Annual Book of ASTM Standards*, Vol 14.03.

*A Summary of Changes section appears at the end of this standard.

8. Apparatus

8.1 *Bath*—Constant-temperature bath designed to maintain a temperature of $15.6 \pm 1^\circ\text{C}$ ($60 \pm 1.8^\circ\text{F}$). If any other temperature must be used due to local conditions, appropriate corrections shall be made.

8.2 *Pycnometer*—Cylindrical or conical glass vessel carefully ground to receive an accurately fitting 24/12 standard taper glass stopper provided with a hole approximately 1.0 to 2.0 mm in diameter, centrally located in reference to the vertical axis. The top surface of the stopper shall be smooth and substantially plane, and the lower surface shall be concave in order to allow all air to escape through the bore. The height of the concave section shall be approximately 5 mm at the center. The stoppered pycnometer shall have a capacity of about 24 to 30 mL, and shall weigh not more than 40 g. Suitable pycnometers are shown in Fig. 1.

TABLE 1 Determination of Bias, Pycnometer Method

Calculated Specific Gravity	Specific Gravity Experimentally Determined	± %Bias	Statistically Significant (95 % Confidence Level)
1.0247	1.0262	-0.049	yes
1.0648	1.0665	+ 0.16	yes
1.1100	1.1119	+ 0.17	yes
1.2299	1.2235	-0.52	yes

TABLE 2 Determination of Bias, Balance Method

Calculated Specific Gravity	Specific Gravity Experimentally Determined	± %Bias	Statistically Significant (95 % Confidence Level)
1.0247	1.0264	-0.166	yes
1.0648	1.0657	+ 0.084	yes
1.1100	1.1126	+ 0.234	yes
1.2299	1.2233	-0.539	yes

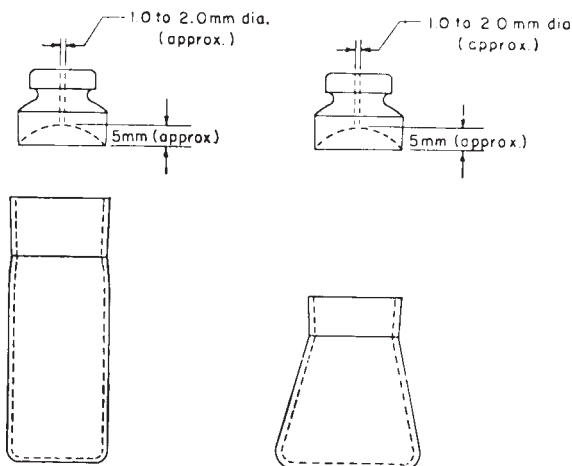

FIG. 1 Suitable Pycnometers

TABLE 3 Determination of Bias, Erlenmeyer Flask Method

Calculated Specific Gravity	Specific Gravity Experimentally Determined	± %Bias	Statistically Significant (95 % Confidence Level)
1.0247	1.026	+ 0.126	yes
1.0648	1.066	+ 0.169	yes
1.1100	1.1121	+ 0.74	no
1.2299	1.2225	-0.60	yes

TABLE 4 Determination of Bias, Hydrometer Method

Calculated Specific Gravity	Specific Gravity Experimentally Determined	± %Bias	Statistically Significant (95 % Confidence Level)
1.0247	1.0256	+ 0.088	no
1.0648	1.0647	-0.099	no
1.1100	1.1106	+ 0.054	no
1.2299	1.2207	-0.74	yes

8.3 *Thermometer*—An ASTM Gravity Thermometer having a range from -20 to $+102^\circ\text{C}$ or -5 to $+215^\circ\text{F}$, as specified, and conforming to the requirements for Thermometer 12C or 12F, respectively, as prescribed in Specification E 1.

9. Procedure

9.1 Weigh a clean, dry, calibrated pycnometer, complete with stopper, on an analytical balance, and record this weight to the nearest 0.1 mg, as *P*.

9.2 Remove the stopper and fill the pycnometer with recently boiled reagent water that has been cooled to room temperature, to within several millimetres of the top. Remove the air bubbles. Immerse the unstoppered pycnometer up to the neck in a constant-temperature bath maintained at $15.6 \pm 1^\circ\text{C}$ ($60 \pm 1.8^\circ\text{F}$). Allow the pycnometer to remain in the bath for a period of time sufficient to establish temperature equilibrium. Twenty minutes is usually sufficient.

9.3 After temperature equilibrium has been established, and before removing from the bath, firmly insert the stopper and remove the excess water from the top of the stopper, taking care to leave the capillary filled. Remove the stoppered pycnometer from the bath and wipe it dry. Immediately weigh the pycnometer, and record this weight to the nearest 0.1 mg, as *W*.

9.4 Empty the reagent water from the pycnometer and dry, or rinse with the sample to be tested.

9.5 Using the sample to be tested, repeat the procedure in accordance with 9.2 and 9.3, recording the weight of the pycnometer containing the sample under test as *S*.

10. Calculation

10.1 Calculate the specific gravity of the sample as follows:

$$\text{Specific gravity} = (S - P) / (W - P)$$

where:

P = weight of the empty pycnometer,

S = weight of the pycnometer and contained sample, and
 W = weight of the pycnometer and contained reagent water.

11. Precision and Bias

11.1 The overall precision (S_T) and single operator precision (S_o) of this test method within their designated ranges vary with quantity being tested in accordance with Fig. 2.

11.2 The bias for this test method, shown in Table 1, was produced in prepared standards by six laboratories in triplicate for four concentrations. The concentration range covered was 1.0247 to 1.2299.

11.3 Precision and bias for this test method conforms to Practice D 2777-77, which was in place at the time of collaborative testing. Under the allowances made in 1.4 of D 2777-98, these precision and bias data do meet existing requirements for interlaboratory studies of Committee D19 test methods.

TEST METHOD B—BALANCE

12. Summary of Test Method

12.1 The specific gravity balance is essentially an analytical balance which uses a plummet to determine the weight of a liquid by displacement. The plummet is calibrated in a standard liquid, usually reagent water, before the determination is made. Any oil present in the sample will interfere with this determination; therefore, only freshly filtered samples should be used.

13. Apparatus

13.1 *Specific Gravity Balance*—A Westphal-type balance or any of several accurate specific gravity balances may be used.

14. Procedure

14.1 Locate the specific gravity balance in a draft-free enclosure. Clean the plummet by immersion in distilled water followed by acetone. Dry with air or a lint-free tissue. Calibrate the plummet by determining its difference in weight in air and in reagent water at $15.6 \pm 1^\circ\text{C}$ ($60 \pm 1.8^\circ\text{F}$); record this displacement as d_1 .

14.2 Immerse the plummet in the sample, which has a stabilized temperature of $15.6 \pm 1^\circ\text{C}$ ($60 \pm 1.8^\circ\text{F}$). Make certain that the plummet does not touch the bottom or the sides of the container. The liquid displacement, d_2 , is the difference between the weight necessary to counterpoise the dry plummet in air and that necessary when the plummet is immersed in the liquid samples.

15. Calculation

15.1 Calculate the specific gravity of the sample as follows:

$$\text{Specific gravity} = \frac{d_2}{d_1}$$

where:

d_1 = difference in weight in air and in reagent water, and

d_2 = difference in weight in air and in the sample.

16. Precision and Bias

16.1 The overall precision (S_T) and single operator precision (S_o) of this test method within their designated ranges vary with quantity being tested in accordance with Fig. 3.

16.2 The bias data for this test method, shown in Table 2, was produced on prepared standards by five laboratories in triplicate for four concentrations. The concentration range covered was 1.0247 to 1.2299.

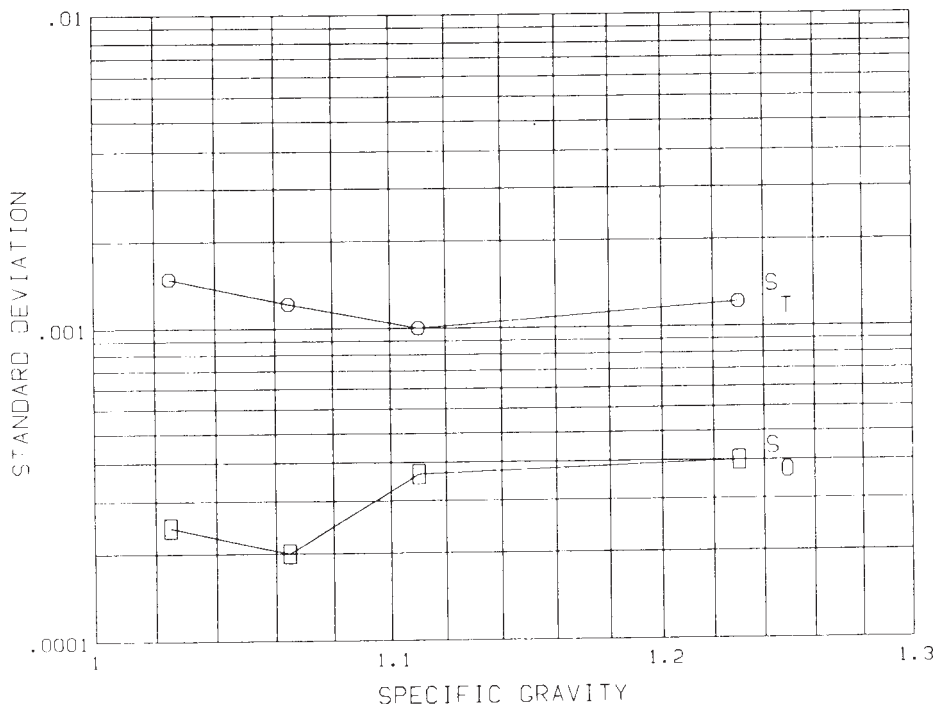

FIG. 2 Interlaboratory Precision for Specific Gravity of Brines by Pycnometer Method

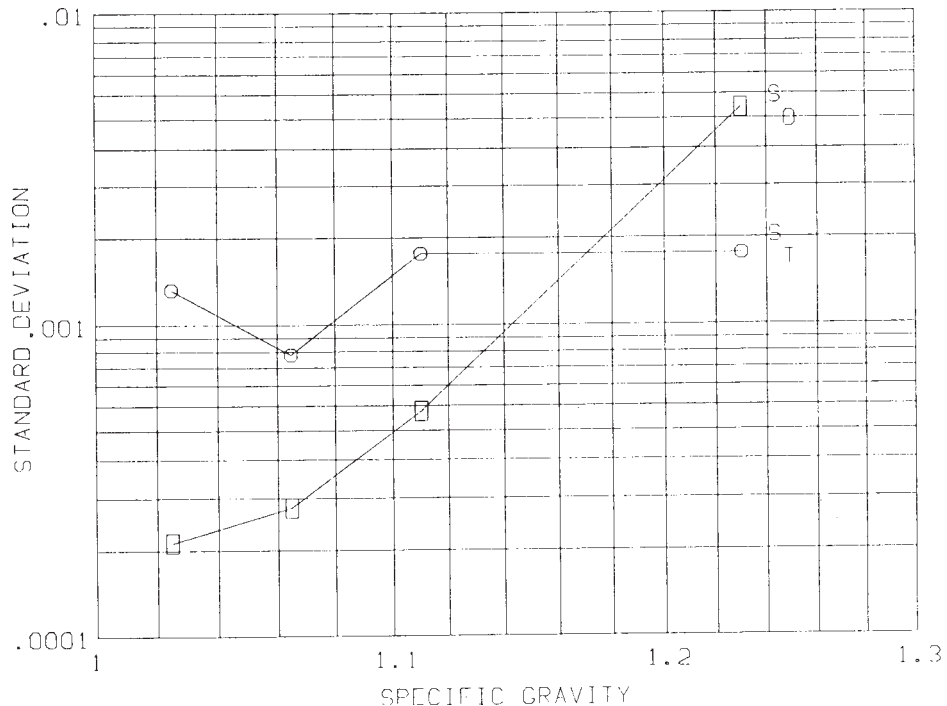

FIG. 3 Interlaboratory Precision for Specific Gravity of Brines by Balance Method

16.3 Precision and bias for this test method conforms to Practice D 2777-77, which was in place at the time of collaborative testing. Under the allowances made in 1.4 of D 2777-98, these precision and bias data do meet existing requirements for interlaboratory studies of Committee D19 test methods.

TEST METHOD C—ERLENMEYER FLASK

17. Summary of Test Method

17.1 The sample of mud or sludge is thoroughly stirred and poured into a wide-mouth Erlenmeyer flask until it is somewhat more than level full, the excess being struck off with a spatula blade. The specific gravity is calculated from this weight and the previously determined weight of water required to fill the flask completely.

17.2 If the sample is of a plastic solid consistency, the flask is partly filled with the sample and weighed. Water is then added to fill the flask completely, and the total weight is taken. The specific gravity is calculated from the weight of the volume of water displaced by the sample.

18. Procedure

18.1 Clean, dry, and weigh the Erlenmeyer flask to the nearest 0.1 g, and record this weight as *F*.

18.2 Fill the flask with reagent water or tap water. Both flask and water shall be at temperature equilibrium. Weigh the filled flask and record this weight as *W*. Empty and dry the flask.

18.3 If the sample flows readily, fill the flask completely with the sample, leveling the upper surface with a flat-bladed

spatula held at an angle of 45° with the rim of the flask. Weigh, and record this weight as *S*.

18.4 Mix the sample thoroughly by stirring, but do not shake. If the sample does not flow readily, add sufficient sample to approximately half fill the flask, without exerting pressure, and weigh. Record the weight of the flask and sample as *R*. Fill the flask containing the sample completely with reagent water or tap water, whichever was used in accordance with 18.2, taking care to remove all entrained air bubbles, and weigh again. Record this weight at *T*.

19. Calculation

19.1 In the case of free-flowing samples, calculate the specific gravity of the sample as follows:

$$\text{Specific gravity} = \frac{(S - F)}{(W - F)}$$

where:

- F* = weight of the empty flask,
- S* = weight of the flask completely filled with sample, and
- W* = weight of the flask and contained water.

19.2 In the case of samples that do not flow readily, calculate the specific gravity of the sample as follows:

$$\text{Specific gravity} = \frac{(R - F)}{(W - F) - (T - R)}$$

where:

- F* = weight of the empty flask,
- R* = weight of the flask partly filled with sample,

T = weight of the flask partly filled with sample, plus water added to fill remaining volume, and
 W = weight of the flask and contained water.

20. Precision and Bias

20.1 The overall precision (S_o) and single operator precision (S_o) of this test method within their designated ranges vary with quantity being tested in accordance with Fig. 4.

20.2 The bias data for this test method, shown in Table 3, was produced on prepared standards by six laboratories in triplicate for four concentrations. The concentration range covered was 1.0247 to 1.2299.

20.3 Precision and bias for this test method conforms to Practice D 2777-77, which was in place at the time of collaborative testing. Under the allowances made in 1.4 of D 2777-98, these precision and bias data do meet existing requirements for interlaboratory studies of Committee D19 test methods.

21. Quality Control

21.1 In order to be certain that analytical values obtained using these test methods are valid and accurate within the confidence limits of the test, the following QC procedures must be followed when analyzing specific gravity.

21.2 Calibration and Calibration Verification

21.2.1 Verify the balance calibration by weighing a weight at several weight limits.

21.3 Initial Demonstration of Laboratory Capability

21.3.1 If a laboratory has not performed the test before, or if there has been a major change in the measurement system, for example, new analyst, and so forth, a precision and bias study must be performed to demonstrate laboratory capability.

21.3.2 Analyze seven replicates of a solution with a known specific gravity. Each replicate must be taken through the complete analytical test method. The replicates may be interspersed with samples.

21.3.3 Calculate the mean and standard deviation of the seven values and compare to the acceptable ranges of bias in sections 11.1, 16.1, and 20.1. This study should be repeated until the recoveries are within the limits given in sections 11.1, 16.1, and 20.1. If an amount other than the recommended amount is used, refer to Practice D5847 for information on applying the F test and t test in evaluating the acceptability of the mean and standard deviation.

21.4 Laboratory Control Sample (LCS)

21.4.1 To ensure that the test method is in control, analyze a LCS having a known specific gravity with each batch or ten samples. If large numbers of samples are analyzed in the batch, analyze the LCS after every ten samples. The LCS must be taken through all of the steps of the analytical method. The result obtained for the LCS shall fall within $\pm 15\%$ of the known specific gravity.

21.4.2 If the result is not within these limits, analysis of samples is halted until the problem is corrected, and either all the samples in the batch must be reanalyzed, or the results must be qualified with an indication that they do not fall within the performance criteria of the test method.

21.5 Method Blank

21.5.1 Analyze a reagent water blank with each batch.

21.6 Matrix Spike (MS)

21.6.1 Specific gravity is not an analyte that can be feasibly spiked into samples.

21.7 Duplicate

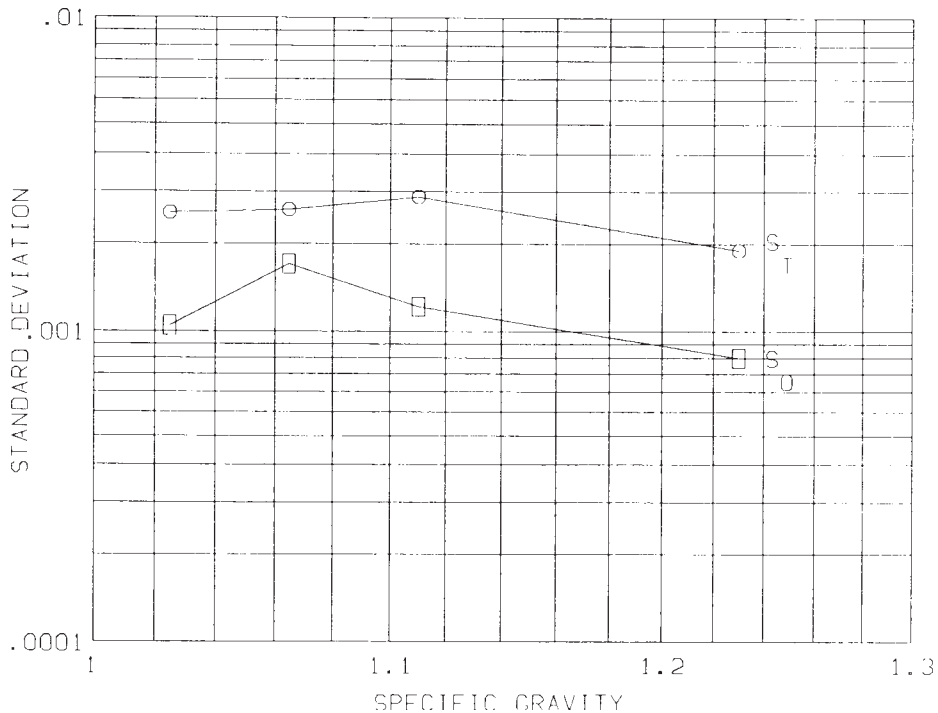

FIG. 4 Interlaboratory Precision for Specific Gravity of Brines by Erlenmeyer Flask Method

21.7.1 To check the precision of sample analyses, analyze a sample in duplicate with each batch. The value obtained must fall within the control limits established by the laboratory.

21.7.2 Calculate the standard deviation of the duplicate values and compare to the precision in the collaborative study using an F test. Refer to 6.4.4 of Practice D 5847 for information on applying the F test.

21.7.3 If the result exceeds the precision limit, the batch must be reanalyzed or the results must be qualified with an indication that they do not fall within the performance criteria of the test method.

21.8 Independent Reference Material (IRM)

21.8.1 In order to verify the quantitative value produced by the test method, analyze an Independent Reference Material (IRM) submitted as a regular sample (if practical) to the laboratory at least once per quarter. The specific gravity of the IRM should be within the control limits established by the laboratory.

TEST METHOD D—HYDROMETER

22. Summary of Test Method

22.1 The hydrometer is a weighted bulb with a graduated stem. The depth to which the hydrometer sinks in a fluid is determined by the density of the fluid. The specific gravity is read directly from the graduated stem. Any oil present in the sample will interfere with the determination; therefore, only freshly filtered samples should be used.

23. Apparatus

23.1 *Hydrometer*—A set of glass hydrometers (equipped with built-in thermometers) covering the range of specific gravities encountered in water and brine analyses. Graduations should not be greater than 0.002.

23.2 *Hydrometer Cylinder* of clear glass, or plastic. For convenience in pouring, the cylinder may have a lip on the rim. The inside diameter of the cylinder shall be at least 25 mm greater than the outside diameter of the hydrometer used. The height of the cylinder shall be such that the hydrometer floats in the sample with at least 25-mm clearance between the bottom of the hydrometer and the bottom of the cylinder.

24. Procedure

24.1 Fill the cylinder with the sample and carefully immerse the hydrometer. The hydrometer must float freely and not touch the sides of the cylinder. Allow the hydrometer to remain in the sample 5 min or until the thermometer establishes equilibrium. Read and record the specific gravity and temperature directly from the hydrometer.

25. Calculation for Correction to 60°F

25.1 The specific gravity may be corrected to 60/60°F by adding 0.0002 for each degree above 60°F. An example is as follows:

Specific gravity at 79°F	1.1225
Correction = (79– 60) 0.0002 =	+ 0.0038
Specific gravity at 60°F	1.1263

26. Precision and Bias

26.1 The overall precision (S_T) and single operator precision (S_o) of this test method within their designated ranges vary with quantity being tested in accordance with Fig. 5.

26.2 The bias data for this test method, shown in Table 4, was produced on prepared standards by six laboratories in triplicate for four concentrations. The concentration range covered was 1.0247 to 1.2299.

26.3 Precision and bias for this test method conforms to Practice D 2777–77, which was in place at the time of

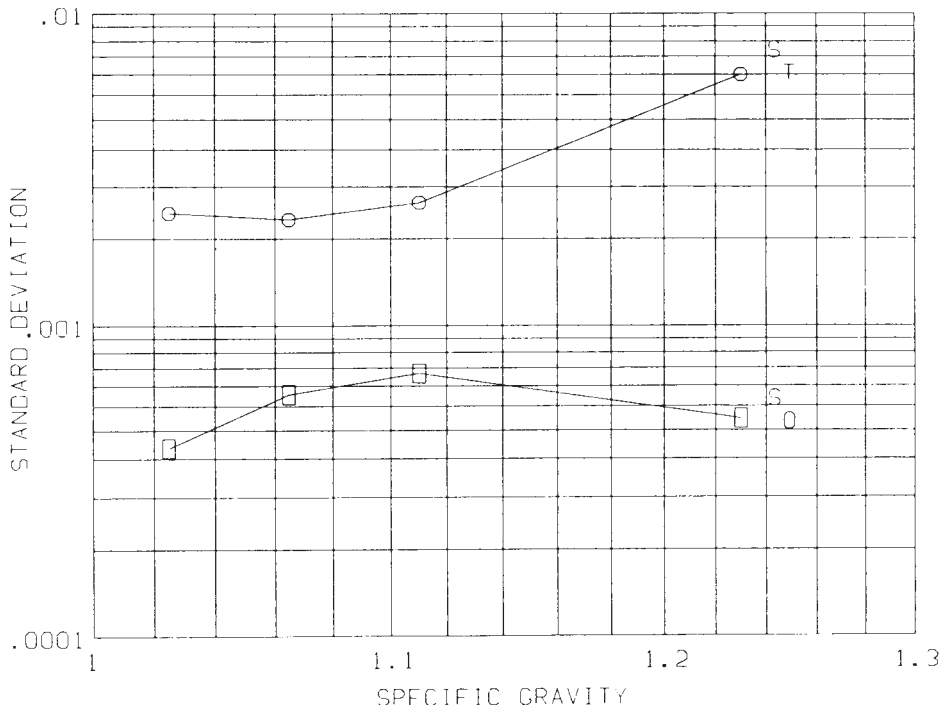

FIG. 5 Interlaboratory Precision for Specific Gravity of Brines by Hydrometer Method

collaborative testing. Under the allowances made in 1.4 of D 2777–98, these precision and bias data do meet existing requirements for interlaboratory studies of Committee D19 test methods.

27. Quality Control

27.1 In order to be certain that analytical values obtained using these test methods are valid and accurate within the confidence limits of the test, the following QC procedures must be followed when analyzing specific gravity.

27.2 Calibration and Calibration Verification

27.2.1 Verify the hydrometer by determining the specific gravity on a sample with a known specific gravity.

27.3 Initial Demonstration of Laboratory Capability

27.3.1 If a laboratory has not performed the test before, or if there has been a major change in the measurement system, for example, new analyst, and so forth, a precision and bias study must be performed to demonstrate laboratory capability.

27.3.2 Analyze seven replicates of a solution with a known specific gravity. Each replicate must be taken through the complete analytical test method. The replicates may be interspersed with samples.

27.3.3 Calculate the mean and standard deviation of the seven values and compare to the acceptable ranges of bias in section 26.1. This study should be repeated until the recoveries are within the limits given in section 26.1. If an amount other than the recommended amount is used, refer to Practice D5847 for information on applying the F test and t test in evaluating the acceptability of the mean and standard deviation.

27.4 Laboratory Control Sample (LCS)

27.4.1 To ensure that the test method is in control, analyze a LCS having a known specific gravity with each batch or ten samples. If large numbers of samples are analyzed in the batch, analyze the LCS after every ten samples. The LCS must be taken through all of the steps of the analytical method. The

result obtained for the LCS shall fall within $\pm 15\%$ of the known specific gravity.

27.4.2 If the result is not within these limits, analysis of samples is halted until the problem is corrected, and either all the samples in the batch must be reanalyzed, or the results must be qualified with an indication that they do not fall within the performance criteria of the test method.

27.5 Method Blank

27.5.1 Analyze a reagent water blank with each batch.

27.6 Matrix Spike (MS)

27.6.1 Specific gravity is not an analyte that can be feasibly spiked into samples.

27.7 Duplicate

27.7.1 To check the precision of sample analyses, analyze a sample in duplicate with each batch. The value obtained must fall within the control limits established by the laboratory.

27.7.2 Calculate the standard deviation of the duplicate values and compare to the precision in the collaborative study using an F test. Refer to 6.4.4 of Practice D 5847 for information on applying the F test.

27.7.3 If the result exceeds the precision limit, the batch must be reanalyzed or the results must be qualified with an indication that they do not fall within the performance criteria of the test method.

27.8 Independent Reference Material (IRM)

27.8.1 In order to verify the quantitative value produced by the test method, analyze an Independent Reference Material (IRM) submitted as a regular sample (if practical) to the laboratory at least once per quarter. The specific gravity of the IRM should be within the control limits established by the laboratory.

28. Keywords

28.1 brine; hydrometer; pycnometer; specific gravity

SUMMARY OF CHANGES

Committee D19 has identified the location of selected changes to this standard since the last issue (D 1429 – 95 (1999)) that may impact the use of this standard.

- | | |
|---|--|
| (1) Section 5.1 was modified. | (3) The QC Sections 21 and 27 were added to the test method. |
| (2) Sections 11.3, 16.3, 20.3, and 26.3 were added. | (4) Keywords were added. |

ASTM International takes no position respecting the validity of any patent rights asserted in connection with any item mentioned in this standard. Users of this standard are expressly advised that determination of the validity of any such patent rights, and the risk of infringement of such rights, are entirely their own responsibility.

This standard is subject to revision at any time by the responsible technical committee and must be reviewed every five years and if not revised, either reapproved or withdrawn. Your comments are invited either for revision of this standard or for additional standards and should be addressed to ASTM International Headquarters. Your comments will receive careful consideration at a meeting of the responsible technical committee, which you may attend. If you feel that your comments have not received a fair hearing you should make your views known to the ASTM Committee on Standards, at the address shown below.

This standard is copyrighted by ASTM International, 100 Barr Harbor Drive, PO Box C700, West Conshohocken, PA 19428-2959, United States. Individual reprints (single or multiple copies) of this standard may be obtained by contacting ASTM at the above address or at 610-832-9585 (phone), 610-832-9555 (fax), or service@astm.org (e-mail); or through the ASTM website (www.astm.org).