



Standard Test Method for Open-Channel Flow Measurement of Water with Thin-Plate Weirs¹

This standard is issued under the fixed designation D 5242; the number immediately following the designation indicates the year of original adoption or, in the case of revision, the year of last revision. A number in parentheses indicates the year of last reapproval. A superscript epsilon (ϵ) indicates an editorial change since the last revision or reapproval.

1. Scope

1.1 This test method covers measurement of the volumetric flowrate of water and wastewater in channels with thin-plate weirs. Information related to this test method can be found in Rantz (1)² and Ackers (2).

1.2 The values stated in inch-pound units are to be regarded as the standard. The SI units given in parentheses are for information only.

1.3 *This standard does not purport to address all of the safety concerns, if any, associated with its use. It is the responsibility of the user of this standard to establish appropriate safety and health practices and determine the applicability of regulatory limitations prior to use.*

2. Referenced Documents

2.1 ASTM Standards:

D 1129 Terminology Relating to Water³

D 2777 Practice for Determination of Precision and Bias of Applicable Methods of Committee D-19 on Water³

D 3858 Practice for Open-Channel Flow Measurement of Water by Velocity-Area Methods³

2.2 ISO Standards:

ISO 1438 Flow Measurement in Open Channels Using Weirs and Venturi Flumes—Part 1: Thin-Plate Weirs⁴

ISO 555 Liquid Flow Measurement in Open Channels, Delusion Methods for Measurement of Steady Flow-Constant Rate Injection Method⁴

3. Terminology

3.1 Definitions:

3.1.1 For definitions of terms used in this test method, refer to Terminology D 1129.

3.2 Definitions of Terms Specific to This Standard:

3.2.1 *crest*—the bottom of the overflow section or notch of a rectangular weir.

3.2.2 *head*—the height of a liquid above a specified point, for example, the weir crest.

3.2.3 *hydraulic jump*—an abrupt transition from supercritical flow to subcritical or tranquil flow.

3.2.4 *nappe*—the curved sheet or jet of water overfalling the weir.

3.2.5 *notch*—the overflow section of a triangular weir or of a rectangular weir with side contractions.

3.2.6 *primary instrument*—the device (in this case the weir) that creates a hydrodynamic condition that can be sensed by the secondary instrument.

3.2.7 *scow float*—an in-stream float for depth sensing, usually mounted on a hinged cantilever.

3.2.8 *secondary instrument*—in this case, a device that measures the depth of flow (referenced to the crest) at an appropriate location upstream of the weir plate. The secondary instrument may also convert the measured depth to an indicated flowrate.

3.2.9 *stilling well*—a small free-surface reservoir connected through a constricted channel to the approach channel upstream of the weir so that a depth (head) measurement can be made under quiescent conditions.

3.2.10 *subcritical flow*—open channel flow in which the average velocity is less than the square root of the product of the average depth and the acceleration due to gravity; sometimes called tranquil flow.

3.2.11 *submergence*—a condition where the water level on the downstream side of the weir is at the same or at a higher elevation than the weir crest; depending on the percent of submergence the flow over the weir and hence the head-discharge relation may be altered.

3.2.12 *supercritical flow*—open channel flow in which the average velocity exceeds the square root of the product of the average depth and the acceleration due to gravity.

3.2.13 *tailwater*—the water level immediately downstream of the weir.

¹ This test method is under the jurisdiction of ASTM Committee D-19 on Water and is the direct responsibility of Subcommittee D19.07 on Sediments, Geomorphology, and Open-Channel Flow.

Current edition approved May 15, 1992. Published September 1992.

² The boldface numbers in parentheses refer to a list of references at the end of the text.

³ *Annual Book of ASTM Standards*, Vol 11.01.

⁴ Available from American National Standards Institute, 11 West 42nd Street, NY, NY 10036.

4. Summary of Test Method

4.1 Thin-plate weirs are overflow structures of specified geometries for which the volumetric flowrate is a unique function of a single measured depth (head) above the weir crest or vertex, the other factors in the head-discharge relation having been experimentally or analytically determined as functions of the shape of the overflow section and approach channel geometry.

5. Significance and Use

5.1 Thin-plate weirs are reliable and simple devices that have the potential for highly accurate flow measurements. With proper selection of the shape of the overflow section a wide range of discharges can be covered; the recommendations in this test method are based on experiments with flowrates from about 0.008 ft³/s (0.00023 m³/s) to about 50 ft³/s (1.4 m³/s).

5.2 Thin-plate weirs are particularly suitable for use in water and wastewater without significant amounts of solids and in locations where a head loss is affordable.

6. Interferences

6.1 Because of the reduced velocities in the backwater upstream of the weir, solids normally transported by the flow will tend to deposit and ultimately affect the approach conditions.

6.2 Weirs are applicable only to open channel flow and become inoperative under pressurized-conduit conditions.

7. Apparatus

7.1 A weir measuring system consists of the weir plate and its immediate channel (the primary) and a depth (head) measuring device (the secondary). The secondary device can range from a simple scale for manual readings to an instrument that continuously senses the depth, converts it to a flowrate, and displays or transmits a readout or record of the instantaneous flowrate or totalized flow, or both.

7.2 Thin-Plate Weir:

7.2.1 *Shapes*—The thin-plate weir provides a precisely shaped overflow section symmetrically located in a (usually) rectangular approach section, as in Fig. 1 and Fig. 2. Although information is available in the literature (3) on a variety of overflow-section or notch shapes (for example, rectangular, triangular, trapezoidal, circular) only the rectangular and triangular shapes are considered to have a data base sufficient for promulgation as a standard method.

7.2.2 Weir Plate:

7.2.2.1 The plate thickness in the direction of flow must be from 0.03 in to 0.08 in. (about 1 to 2 mm); the lower limit is prescribed to minimize potential damage, and the upper limit is required to help avoid nappe clinging. See 7.2.5.4 and 7.2.6.3 for plates thicker than 0.08 in. (2 mm). The plate must be fabricated of smooth metal or other material of equivalent smoothness and sturdiness. Upstream corners of the overflow section must be sharp and burr-free, and the edges must be flat, smooth, and perpendicular to the weir face.

7.2.2.2 The plane of the weir plate must be vertical and perpendicular to the channel walls. The overflow section must be laterally symmetrical and its bisector must be vertical and

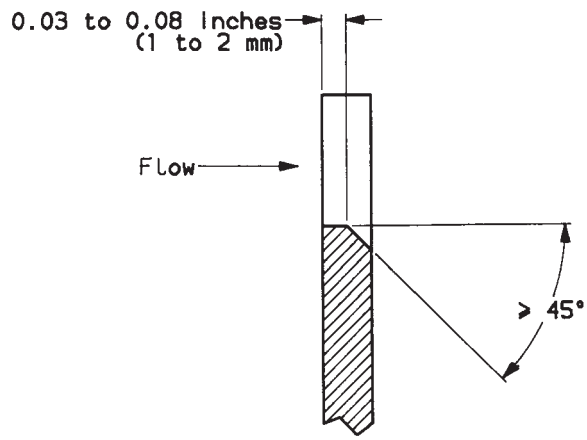
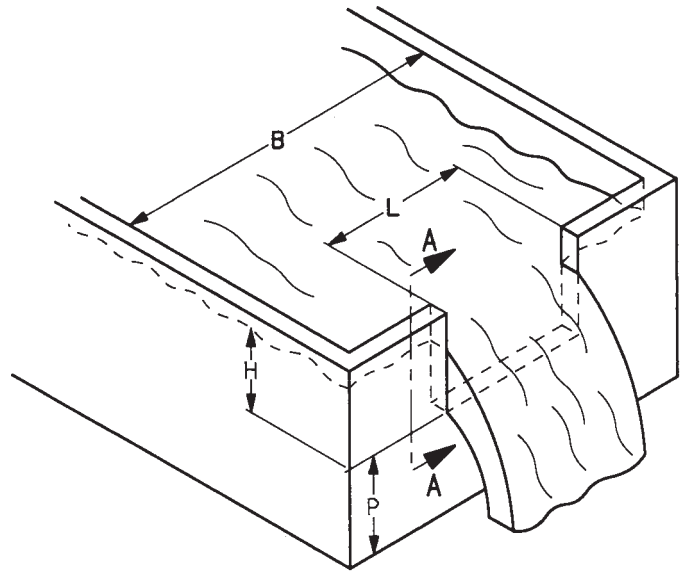

Notch edge section (A-A).

FIG. 1 Rectangular Weir

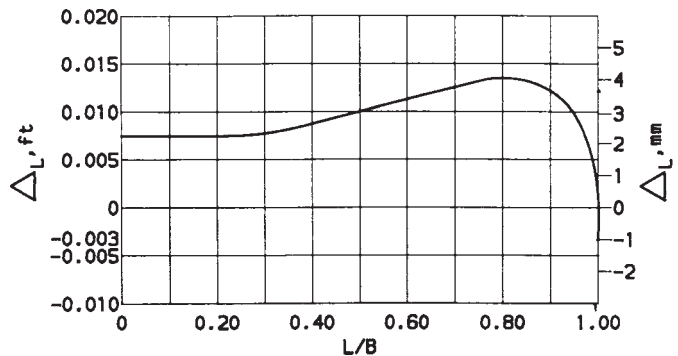

FIG. 2 Crest-Length Adjustment, Δ_L

located at the lateral midpoint of the approach channel. If the metal plate containing the overfall section does not form the entire weir, it must be mounted on the remainder of the

bulkhead so that the upstream face of the weir is flush and smooth. (This requirement may be relaxed if the metal plate is large enough in itself to form full contractions. See 7.2.3.) The weir structure must be firmly mounted in the channel so that there is no leakage around it.

7.2.2.3 Additional plate requirements specific to rectangular and triangular weirs are given in 7.2.5.4 and 7.2.6.3.

7.2.3 Weir Contractions—When the sidewalls and bottom of the approach channel are far enough from the edges of the notch for the contraction of the nappe to be unaffected by those boundaries, the weir is termed “fully contracted”. With lesser distances to the bottom or sidewalls, or both, the weir is “partially contracted”. Contraction requirements specific to rectangular and triangular weirs are given in 7.2.5.3, 7.2.5.6, 7.2.6.2, and 7.2.6.5.

7.2.4 Head Measurement Location—The head on the weir, H , is measured as a depth above the elevation of the crest or vertex of the notch. This measurement should be made at a distance upstream of the weir equal to $4H_{max}$ to $5H_{max}$, where H_{max} is the maximum head on the weir. In some cases a stilling well may be desirable or necessary. See 7.5.

7.2.5 Rectangular Weirs:

7.2.5.1 The rectangular overflow section can have either full or partial contractions (7.2.3) or the side contractions may be suppressed (7.2.5.2).

7.2.5.2 Suppressed Weirs—When there are no side contractions and the weir crest extends across the channel, the weir is termed “full width” or “suppressed”. In this case the approach channel must be rectangular (see also 7.3.4) and the channel walls must extend at least $0.3H$ downstream of the weir plate.

7.2.5.3 Contracted Rectangular Weirs—The conditions for full contraction are as follows:

$$\begin{aligned} H/P &\leq 0.5 \\ H/L &\leq 0.5 \\ 0.25 \text{ ft (0.08 m)} &\leq H \leq 2.0 \text{ ft (0.6 m)} \\ L &\geq 1.0 \text{ ft (0.3 m)} \\ P &\geq 1.0 \text{ ft (0.3 m)} \\ (B - L)/2 &\geq 2H \end{aligned}$$

where H is the measured head, P is the crest height above the bottom of the channel, L is the crest length, and B is the channel width. The partial contraction conditions covered by this test method are given in 7.2.5.6.

7.2.5.4 Weir Plate—The requirements of this section are in addition to those of 7.2.2. If the plate is thicker than 0.08 in. (2 mm) the downstream excess at the edges of the overflow section must be beveled at an angle of at least 45° as shown in Fig. 1. If there are side contractions, all of the edge requirements of this test method pertain to the sides as well as the crest. The sides must be exactly perpendicular to the crest; and the crest must be level, preferably to within a transverse slope of 0.001.

7.2.5.5 Discharge Relations—The flowrate, Q , over a rectangular weir that conforms to all requirements of 7.2 as well as the approach conditions in 7.3 is determined from the Kindsvater-Carter equation (4):

$$Q = (2/3)(2g)^{1/2} C_e L_e (H_e)^{3/2} \tag{1}$$

where g is the acceleration due to gravity in compatible units, H_e and L_e are the effective head and effective crest length

respectively, and C_e is a discharge coefficient. The effective head, H_e , is related to the measured head, H , by:

$$H_e = H + \delta H$$

where δH is an experimentally determined adjustment for the effects of viscosity and surface tension valid for water at ordinary temperatures (about 4 to 30°C); its value is constant at 0.003 ft (0.001 m). The effective crest length, L_e , is related to the measured length, L , by:

$$L_e = L + \delta L$$

where the adjustment, δL , is a function of the crest length-to-channel width ratio, L/B . Experimentally determined values of δL for water at ordinary temperatures are given in Fig. 3.

The discharge coefficient, C_e , is given in Fig. 4 as a function of L/B and the head-to-crest height ratio, H/P .

7.2.5.6 Limits of Application—The discharge relations given in 7.2.5.5 are applicable for these conditions:

$$\begin{aligned} H/P &\leq 2 \\ H &\geq 0.1 \text{ ft (0.03 m)} \\ L &\geq 0.5 \text{ ft (0.15 m)} \\ P &\geq 0.3 \text{ ft (0.1 m)} \end{aligned}$$

Although in principle Eq 1 could be applied to very large weirs, the experiments on which it is based included crest lengths up to about 4 ft (1.2 m) and heads up to about 2 ft (0.6 m); it is recommended that these values not be significantly exceeded.

7.2.5.7 Aeration Requirements—In order to avoid nappe clinging and maintain proper aeration of the nappe, the tailwater level should always be at least 0.2 ft (0.06 m) below the crest. In addition, in the case of suppressed weirs, aeration must be provided externally; this can be done with sidewall vents, for example. The user must measure the pressure in the air pocket to establish that it is sufficiently close to atmospheric for the flow to be unaffected (see 11.7.2).

7.2.6 Triangular Weirs:

7.2.6.1 Shape—The overflow section of a triangular weir is an isosceles triangle oriented with the vertex downward. Experimental results are available for notch angles, θ , of 20 to

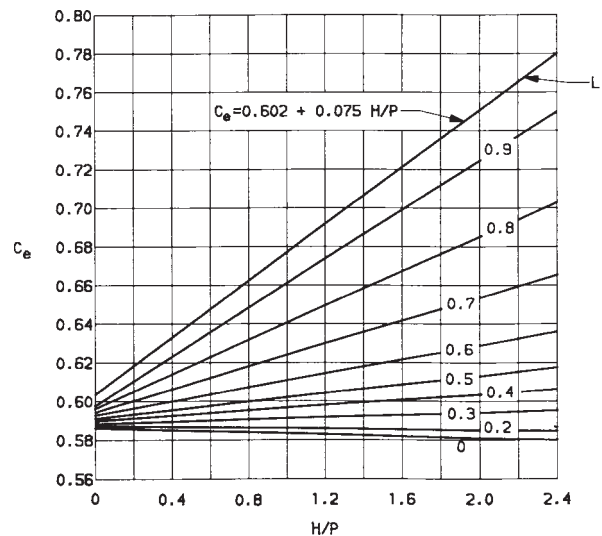

FIG. 3 Discharge Coefficient, C_e , for Rectangular Weirs

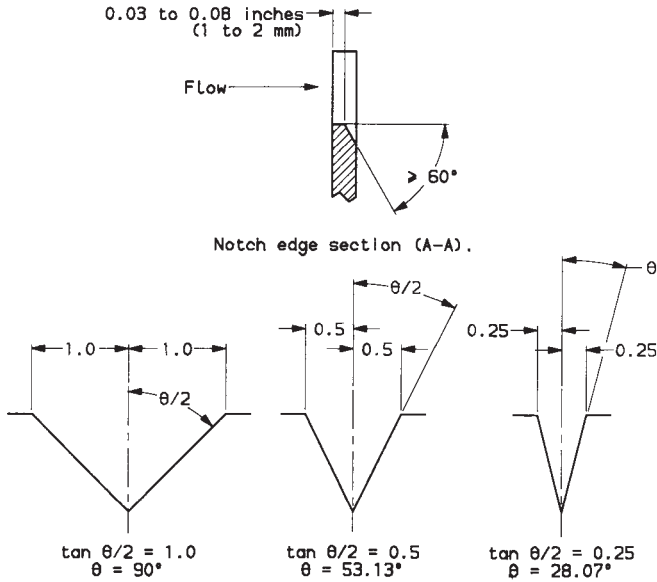
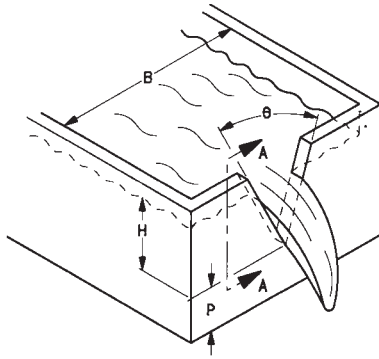

FIG. 4 Triangular Weirs

100°. However, the most commonly used weirs are 90° (tan $\theta/2 = 1$), 53.13° (tan $\theta/2 = 0.5$) and 28.07° (tan $\theta/2 = 0.25$). See Fig. 2.

7.2.6.2 *Contractions*—The conditions for full contraction of triangular weirs are as follows:

$$\begin{aligned} H/P &\leq 0.4 \\ H/B &\leq 0.2 \\ P &\geq 1.5 \text{ ft (0.45 m)} \\ B &\geq 3.0 \text{ ft (0.9 m)} \\ 0.15 \text{ ft (0.05 m)} &\leq H \leq 1.25 \text{ ft (0.38 m)} \end{aligned}$$

The conditions for partial contraction covered by this test method are listed in 7.2.6.5.

7.2.6.3 *Weir Plate*—If the plate is thicker than 0.08 in. (2 mm) the downstream excess at the notch must be beveled at an angle of at least 60° (Fig. 2). This requirement is in addition to those of 7.2.2.

7.2.6.4 *Discharge Relations*—The flowrate over a triangular weir that conforms to all requirements of 7.2.3 as well as the approach conditions in 7.3 is determined from the following:

$$Q = (8/15)(2g)^{1/2} C_{e_t} \tan(\theta/2) (H_{e_t})^{5/2} \quad (2)$$

where C_{e_t} and H_{e_t} are the discharge coefficient and effective head respectively. H_{e_t} is given by:

$$H_{e_t} = H + \delta_{H_t}$$

where δ_{H_t} is an adjustment for the combined effects of viscosity and surface tension for water at ordinary temperatures (4 to 30°C) and is given as a function of notch angle in Fig. 5. The discharge coefficient is given in Fig. 6 as a function of the notch angle for fully contracted weirs only. For partially contracted weirs the data base is considered adequate for 90° notches only and these discharge coefficients are shown in Fig. 7.

7.2.6.5 *Limits of Application*—For 90° notches only, the discharge relations given in 7.2.6.4 are valid for these partially contracted conditions:

$$\begin{aligned} H/P &\leq 1.2 \\ H/B &\leq 0.4 \\ P &\geq 0.3 \text{ ft (0.1 m)} \\ B &\geq 2 \text{ ft (0.6 m)} \\ 0.15 \text{ ft (0.05 m)} &\leq H \leq 2 \text{ ft (0.6 m)} \end{aligned}$$

For other angles between 20 and 100° the discharge relations are valid only for full contractions (see 7.2.6.2).

7.2.6.6 *Aeration Requirements*—In order to avoid nappe clinging and maintain proper aeration of the nappe, the tailwater level should always be at least 0.2 ft (0.05 m) below the vertex of the triangular notch.

7.3 *Approach Channel:*

7.3.1 Weirs can be sensitive to the quality of the approach flow. Therefore this flow should be tranquil and uniformly distributed across the channel in order to closely approximate the conditions of the experiments from which the discharge relations were developed. For this purpose, uniform velocity distribution can be defined as that associated with fully developed flow in a long, straight, moderately smooth channel. Unfortunately there are no universally accepted quantitative guidelines for implementing these recommendations. One standard (5) recommends a straight approach length of ten channel widths when the weir length is greater than half the channel width. However, the presence of upstream channel bends or sudden enlargements would clearly lengthen this approach requirement. Therefore the adequacy of the approach flow generally must be demonstrated on a case-by-case basis using velocity traverses, experience with similar situations, or analytical approximations.

7.3.2 In some cases baffles can be used to improve the velocity distribution; they must be placed more than 10H upstream of the head measurement location.

7.3.3 If the flow in the channel is supercritical, the installation should be designed so that the hydraulic jump is formed at

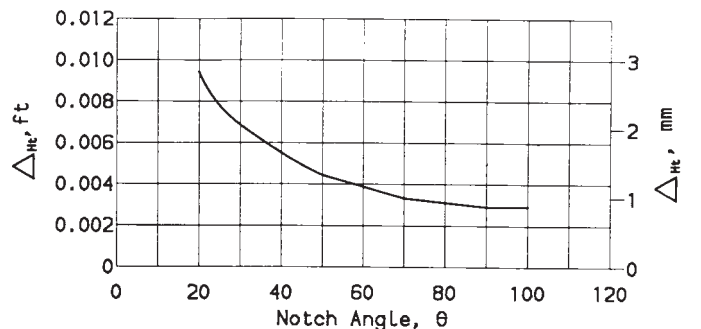

FIG. 5 Head Correction, ΔH_t , for Triangular Weirs

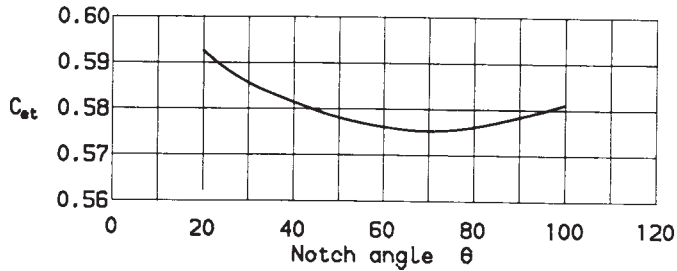

FIG. 6 Discharge Coefficient, C_{ep} , for Triangular Weirs, Fully Contracted Only

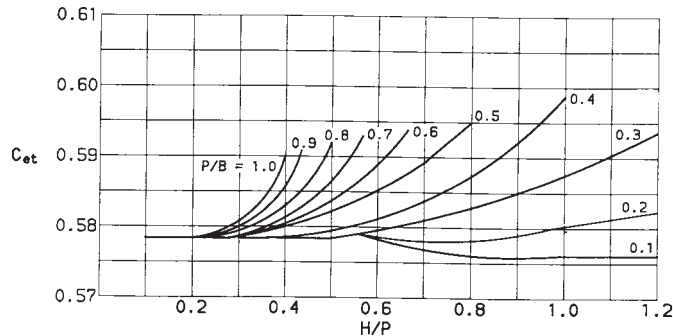

FIG. 7 Discharge Coefficient, C_{ep} , for Partially Contracted 90° Triangular Weirs

least $30H$ upstream and the velocity distribution should be checked for uniformity.

7.3.4 Channel Shape—A rectangular approach channel is preferred in the immediate vicinity of the weir. However, a different shape is acceptable provided the conditions for full contraction are met and the cross-sectional area of the channel is at least as large as the smallest rectangular section that would have provided full contraction. Rectangular channels are required for suppressed rectangular weirs.

7.4 Submerged Weirs—This section provides limited information on the performance of submerged weirs. However, it is strongly recommended that weir installations be designed for free flow because the experimental data base for submerged conditions is not adequate to provide the accuracy appropriate for a standard test method. Further, submerged conditions require that an additional head (relative to the crest or vertex) be measured downstream of the weir so that the submergence (ratio of downstream head to upstream head) can be determined; this measurement must be made in a manner that is unaffected by the disturbances downstream of the overflow. Estimates of the submerged-to-free flowrate ratio, Q_s/Q , where Q is the free flowrate computed from the upstream head, can be obtained from Table 1 for rectangular weirs and 90° triangular weirs (the only triangular notches for which experiments are available). Table 1 indicates that the submergence effect on triangular weirs is substantially less than that on rectangular weirs.

7.4.1 It is emphasized that Table 1 is based on limited experiments. For rectangular weirs the accuracy is probably no better than 5% for submergence ratios up to about 0.50 and small values of H/P . The accuracy for 90° triangular weirs cannot be quantified but it is expected to be superior to that for rectangular weirs.

TABLE 1 Submergence Corrections

Submergence Ratio, S	Q_s/Q Rectangular ^A	Q_s/Q 90° Notch ^B
0	1.000	1.000
0.1	1.007	0.999
0.2	0.978	0.993
0.3	0.939	0.981
0.4	0.895	0.960
0.5	0.842	0.928
0.6	0.778	0.882
0.7	0.698	0.816
0.8	0.589	0.721
0.9	0.435	0.569

^AFrom Table 13 of Ref (6).

^BFrom $Q_s/Q = (1 - S^{2.5})^{0.385}$, on p. 28 of Ref (6).

7.5 Stilling Well and Connector:

7.5.1 Stilling wells are recommended for accurate head measurements; they are required when wire-supported cylindrical floats are used or when the water surface in the channel is wavy or ruffled.

7.5.2 The lateral area of the stilling well is governed in part by the requirements of the secondary instrument. For example, the clearance between a float and the stilling-well wall should be at least 0.1 ft (3 cm) and should be increased to 0.25 ft (7.6 cm) if the well is made of concrete or other rough material, the float diameter itself being determined in part by permissible float lag error (see 11.6.1). Other types of sensors may also impose size requirements on the stilling well, and the maximum area may be limited by response lag. The height of the stilling well must be sufficient to accommodate the anticipated head range.

7.5.3 The stilling well and connector pipe must be leak-proof. Provision should be made for cleaning and flushing the well and pipe to remove any accumulated solids. It may be desirable to add a small purge flow of clean water to help keep the well, connector, and sensor parts clean. This flow should be low enough for any depth increase in the stilling well to be imperceptible.

NOTE 1—Although thin-plate weirs are not likely to be used in flows with obviously heavy solids loads, there might still be gradual solids accumulation in applications such as treated or partially treated wastewater.

7.5.4 The opening in the channel sidewall connecting to the stilling well either directly or through a pipe must be at least 0.2 ft (0.06 m) below the minimum water level and have a perpendicular, flush and burr-free junction with the wall. The wall should be smooth (at least equivalent to a smooth concrete) within a radius of at least ten hole diameters around the center of the hole. The hole or pipe must be small enough to effectively dampen surface disturbances yet not so small that it introduces a lag in the response to varying flowrates or is difficult to keep open. For relatively steady flows in clean water, diameters of about $\frac{1}{2}$ in. (1.3 cm) may suffice. In the case of rapidly varying flows, the connector sizes needed to restrict the stilling-well lag to a desired amount can be determined from hydraulic principles.

7.6 Secondary Instrumentation:

7.6.1 A minimal secondary system for continuous monitoring would contain a depth (head) sensing device and an



indicator or recorder from which the user could determine flowrates from the head-discharge relations. Optionally, the secondary system could convert the measured head to an indicated or recorded flowrate, or both, and totalized flow, and further could transmit the information electrically or pneumatically to a central location.

7.6.2 Continuous head measurements can be made with several types of sensors including, but not restricted to, the following:

7.6.2.1 *Floats*, for example, cylindrical or scow types,

7.6.2.2 *Pressure Sensors*, for example, bubble tubes, diaphragm gages, and

7.6.2.3 *Electrical Sensors*, for example, resistance, capacitance, oscillating probes.

8. Sampling

8.1 Sampling as defined in Terminology D 1129 is not applicable in this test method.

9. Calibration

9.1 In-place calibration of the entire weir system is necessary for highest accuracy if any nonstandard features exist. Calibration of the secondary instrument alone will suffice provided the weir itself meets all the fabrication, installation and approach requirements of 7.2 and 7.3 and provided further that the basic error associated with such a standard weir (see 11.4) is acceptable for the specific measurement purpose. Volumetric or weighting measurement techniques are considered superior to properly designed and operated sharp-crested weirs.

9.2 *Calibrating the Secondary System:*

9.2.1 Make independent reference head measurements with a scale or preferably a point gage to check the secondary instrument. These measurements are most accurately made in the stilling well or in an auxiliary well if needed. The zero of the scale or point gage must be carefully referenced to the crest or vertex elevation.

9.2.2 Compare the reference head (see 9.2.1) with the head indicated by the secondary instrument. If the secondary readout is in terms of flowrate, compare the indicated flowrate with the flowrate computed from the reference head and Eq 1 or Eq 2. Repetition of this process over a range of heads will indicate whether zero or span adjustment is required. Repetition of individual points will provide information on the precision of the system.

9.3 *Calibrating the Complete System:*

9.3.1 Methods for in-place weir calibration include velocity-area traverse (see Test Method D 3858), tracer dilution (see ISO 555), tracer velocity (7), volumetric or gravimetric, and comparison with reference flowrate meter.

9.3.2 There is no single calibration method that is applicable to all field situations, and in many cases only the first two methods of 9.3.1 can even be considered. For example, suitable basins and connecting conduits for direct volumetric calibration of large flows are seldom available; and a reference flowmeter, for example, venturi or orifice meter, for which published standards can be used only where there is adequate approach length for the standard to be applicable. Whatever method is used, conduct the calibration tests at enough flow-

rates with enough repetitions to establish the head-discharge relation. Use a scale or point gage to measure heads during these tests. Calibrate the secondary separately from the primary so that future performance checks need only involve the secondary, provided that conditions related to the primary remain unchanged.

10. Procedure

10.1 After initial calibration according to 9.2 or 9.3, compare the secondary measurement daily with a reference measurement until a suitable frequency of monitoring can be established from the accumulated data.

10.2 Make routine equipment checks frequently at first, in some cases daily, until a more suitable frequency can be derived from the performance history. These include, but are not limited to, purge flows, solids accumulation in the approach channel and stilling well, algal growth, weed and reed growth in the channel, secondary-sensor condition, crest level, etc. Particular attention must be given to the weir surface and overflow-edge conditions, which are sensitive to erosion and damage. Perform maintenance on the secondary instrumentation as recommended in the manufacturers' literature.

11. Precision and Bias

11.1 Determination of precision and bias for this test method is not possible, both at the multiple and single operator level, due to the high degree of instability of open-channel flow. Both temporal and spatial variability of the boundary and flow conditions do not allow for a consent standard to be used for representative sampling. A minimum bias, measured under ideal conditions, is directly related to the bias of the equipment used and is listed in the following sections. A maximum precision and bias cannot be estimated due to the variability of the sources of potential errors listed in this section and the temporal and spatial variability of open-channel flow. Any estimate of these errors could be very misleading to the user.

11.2 In accordance with 1.6 of Practice D 2777, an exemption to the precision and bias statement required by Practice D 2777 was recommended by the results advisor and concurred with by the Technical Operations Section of the Executive Subcommittee on June 15, 1990.

11.3 The error of a weir flowrate measurement results from a combination of individual errors, including errors in the basic head-discharge relation, errors in head measurement, errors in weir coefficient due to weir imperfections and approach conditions, and errors from other sources, some of which are cited in the following.

11.4 *Accuracy of Head-Discharge Relations*—For weirs that are in good condition and meet all the requirements of this test method, the following uncertainties apply to the discharge coefficients and length and head adjustments in Eq 1 and Eq 2.

11.4.1 *Rectangular Weirs:*

11.4.1.1 C_e (full contractions), $\pm 1\%$,

11.4.1.2 C_e (partial contractions), $\pm 2\%$,

11.4.1.3 δ_L , ± 0.001 ft (0.0003 m), and

11.4.1.4 δ_H , ± 0.001 ft (0.0003 m).

11.4.2 *Triangular Weirs:*

11.4.2.1 C_e (full contractions), $\pm 1\%$,

11.4.2.2 C_e (partial contractions, 90°), $\pm 2\%$, and



11.4.2.3 $\delta_{H_t} \pm 0.001$ ft (0.0003 m).

11.5 Errors Due to Weir Condition:

11.5.1 *Weir Plate Condition*—Rounded upstream corners in the notch and roughened surfaces on the upstream face of the weir plate, whether caused by wear, corrosion, or algal growth, tend to increase the discharge coefficient. These effects become relatively more important as the head decreases. Errors as large as 2 % for a rounding radius of 0.04 in. (1 mm) have been reported (8). In general these rounding and roughness effects cannot be quantified and careful monitoring and maintenance of plate condition are necessary.

11.5.2 *Weir Crest Level*—The error caused by a small transverse slope of the crest of a rectangular weir can be minimized if the zero of the head measurement is referenced to the mid-point of the crest. Percentage errors associated with non-level crests increase with decreasing head and with increasing crest length.

11.6 Secondary System Errors:

11.6.1 Some potential error sources are associated with specific types of secondary instruments. Examples include, but are not limited to, the following: acoustic devices may incorrectly sense surfaces covered with dense foam; bubbler-tube tips placed in flowing water may be subject to errors due to dynamic pressures, unless properly shaped; grease coatings may affect some types of wire probes; and float systems are subject to lag error if a measurable change in water level is needed to overcome the internal movement friction of the mechanism.

11.6.1.1 Except for the last example, such errors cannot be quantified and only cautionary statements can be made. Each situation must be individually evaluated based on experience, manufacturers' information, and the technical literature. In the case of float systems the potential lag error can be estimated from a measurement of the force needed to overcome friction and application of physical principles. In general the larger the float the more sensitivity to stage changes.

11.6.2 Regardless of the type of secondary device employed, any error in referencing its zero to the weir crest or vertex will introduce an error in head that is constant in magnitude and therefore relatively more important at low flows. See also 11.5.2.

NOTE 2—Triangular weirs are particularly sensitive to errors in head measurement because of the large exponent of head in the discharge equation.

11.6.3 Humidity effects on recorder chart paper can introduce errors of about 1 %.

11.7 Other Error Sources:

11.7.1 *Approach Conditions*—The errors introduced by distorted velocity profiles in the approach flow cannot be quantified, and measuring stations at which the upstream channels do not meet the conditions of 7.3 will generally require in-place calibration to ensure accuracy. Fully contracted weirs are likely

to be less sensitive than partially contracted or suppressed weirs to such velocity gradients.

11.7.2 *Aeration*—Lack of sufficient aeration tends to force the nappe downward and to increase the discharge coefficient. Limited empirical information is available for suppressed weirs (3) that relates the error in flowrate to the ratio of the underpressure in the air pocket (in terms of height of water below atmospheric) to the head on the weir. As an example, an underpressure ratio of 0.04 causes a flow-rate error of about 1 %, with the relationship (for purposes of approximation) being roughly linear.

11.8 Estimating the Total Measurement Error:

11.8.1 One method of estimating the total percentage error of a flow measurement uses the square root of the sum of the squares of the individual error contributions. For example, for the standard weirs of Section 7 this becomes

$$e_t = [(e_1)^2 + (e_2)^2 + n^2 (e_3)^2]^{\frac{1}{2}} \quad (3)$$

where:

- e_t = estimated total percentage error of a flow measurement,
- e_1 = estimated percentage error in the discharge coefficient, C_e or C_{e_t} ,
- e_2 (*rectangular weirs*) = estimated percentage error in the crest length, obtained by combining (square root of the sum of the squares) the estimated error of crest length measurement with the 0.001 ft (0.0003 m) error in the length adjustment term,
- e_2 (*triangular weirs*) = estimated percentage error in $\tan \theta/2$,
- n = exponent of the head in the discharge equation, 1.5 and 2.5 for rectangular and triangular weirs respectively, and
- e_3 = estimated percentage error in the effective head, obtained by combining (square root of the sum of the squares) estimates of all individual contributions to the head measurement error with the 0.001 ft (0.0003 m) error in the head adjustment term

11.8.2 Equations similar to Eq 3 can be developed to include head-discharge relations obtained from in-place calibrations or to accommodate other error sources. Additional details on estimating total error can be found in Refs (3) and (5) and in ISO 1438.

12. Keywords

12.1 flow measurement; open-channel flow; water discharge; weirs



REFERENCES

- (1) Rantz, S. E., "Measurement and Computation of Streamflow, Vol I—Measurement of Stage and Discharge," U.S. Geological Survey Water Supply Paper 2175, 1982.
- (2) Ackers, P. et al., *Weirs and Flumes for Flow Measurement*, John Wiley and Sons, 1978.
- (3) Bos, M. G., ed., *Discharge Measurement Structures*, Int. Inst. for Land Reclamation and Improvement, Wageningen, Netherlands, Publ. 20. (Also Delft Hydraulics Lab. Publ. 161).
- (4) Kindsvater, C. E., and Carter, R. W., "Discharge Characteristics of Rectangular Thin-Plate Weirs", Jour. Hydraulics Div., *Proc. Amer. Soc. Civ. Eng.*, Vol 83, No. HY6, December 1957.
- (5) British Standards Institution, BSI 3680, "Methods of Measurement of Liquid Flow in Open Channels, Part 4: Weirs and Flumes—4A: Thin-Plate Weirs and Venturi Flumes."
- (6) U.S. Bureau of Reclamation, *Water Measurement Manual*, Second edition, revised reprint, U.S. Govt. Printing Office, 1984.
- (7) American Society of Mechanical Engineers, *Fluid Meters—Their Theory and Application*, Sixth edition, 1971.
- (8) Thomas, C. W., "Errors in Measurement of Irrigation Water," *Jour. Irrig. & Drain. Div., Proc. Amer. Soc. Civ. Eng.*, Vol 83, Proc. Paper 1362, September 1957.

ASTM International takes no position respecting the validity of any patent rights asserted in connection with any item mentioned in this standard. Users of this standard are expressly advised that determination of the validity of any such patent rights, and the risk of infringement of such rights, are entirely their own responsibility.

This standard is subject to revision at any time by the responsible technical committee and must be reviewed every five years and if not revised, either reapproved or withdrawn. Your comments are invited either for revision of this standard or for additional standards and should be addressed to ASTM International Headquarters. Your comments will receive careful consideration at a meeting of the responsible technical committee, which you may attend. If you feel that your comments have not received a fair hearing you should make your views known to the ASTM Committee on Standards, at the address shown below.

This standard is copyrighted by ASTM International, 100 Barr Harbor Drive, PO Box C700, West Conshohocken, PA 19428-2959, United States. Individual reprints (single or multiple copies) of this standard may be obtained by contacting ASTM at the above address or at 610-832-9585 (phone), 610-832-9555 (fax), or service@astm.org (e-mail); or through the ASTM website (www.astm.org).