



Standard Test Method for Open-Channel Flow Measurement by Acoustic Velocity Meter Systems¹

This standard is issued under the fixed designation D 5389; the number immediately following the designation indicates the year of original adoption or, in the case of revision, the year of last revision. A number in parentheses indicates the year of last reapproval. A superscript epsilon (ε) indicates an editorial change since the last revision or reapproval.

1. Scope

1.1 This test method covers the measurement of flow rate of water in open channels, streams, and closed conduits with a free water surface.

1.2 The test method covers the use of acoustic transmissions to measure the average water velocity along a line between one or more opposing sets of transducers—by the time difference or frequency difference techniques.

1.3 The values stated in SI units are to be regarded as the standard.

1.4 *This standard does not purport to address all of the safety concerns, if any, associated with its use. It is the responsibility of the user of this standard to establish appropriate safety and health practices and determine the applicability of regulatory limitations prior to use.* Specific precautionary statements are given in Section 6.

2. Referenced Documents

2.1 ASTM Standards:

D 1129 Terminology Relating to Water²

D 2777 Practice for Determination of Precision and Bias of Applicable Methods of Committee D19 on Water²

D 3858 Test Method for Open-Channel Flow Measurement of Water by Velocity-Area Method²

2.2 ISO Standard:

ISO 6416 Liquid Flow Measurements in Open Channels—Measurement of Discharge by the Ultrasonic (Acoustic) Method³

3. Terminology

3.1 *Definitions*—For definitions of terms used in this test method, refer to Terminology D 1129.

3.2 Definitions of Terms Specific to This Standard:

3.2.1 *acoustic path*—the straight line between the centers of two acoustic transducers.

3.2.2 *acoustic path length*—the face-to-face distance between transducers on an acoustic path.

3.2.3 *acoustic transducer*—a device that is used to generate acoustic signals when driven by an electric voltage, and conversely, a device that is used to generate an electric voltage when excited by an acoustic signal.

3.2.4 *acoustic travel time*—the time required for an acoustic signal to propagate along an acoustic path, either upstream or downstream.

3.2.5 *discharge*—the rate of flow expressed in units of volume of water per unit of time. The discharge includes any sediment or other materials that may be dissolved or mixed with it.

3.2.6 *line velocity*—the downstream component of water velocity averaged over an acoustic path.

3.2.7 *measurement plane*—the plane formed by two or more parallel acoustic paths of different elevations.

3.2.8 *path velocity*—the water velocity averaged over the acoustic path.

3.2.9 *stage*—the height of a water surface above an established (or arbitrary) datum plane; also gage height.

3.2.10 *velocity sampling*—means of obtaining line velocities in a measurement plane that are suitable for determining flow rate by a velocity-area integration.

4. Summary of Test Method

4.1 Acoustic velocity meter (AVM) systems, also known as ultrasonic velocity meter (UVM) systems, operate on the principle that the point-to-point upstream traveltime of an acoustic pulse is longer than the downstream traveltime and that this difference in travel time can be accurately measured by electronic devices.

4.2 Most commercial AVM systems that measure streamflow use the time-of-travel method to determine velocity along an acoustic path set diagonal to the flow. This test method⁴ describes the general formula for determining line velocity defined as (Fig. 1 and Fig. 2):

$$V_L = \frac{B}{2 \cos \theta} \left[\frac{1}{t_{CA}} - \frac{1}{t_{AC}} \right] \quad (1)$$

¹ This test method is under the jurisdiction of ASTM Committee D19 on Water and is the direct responsibility of Subcommittee D19.07 on Sediments, Geomorphology, and Open-Channel Flow.

Current edition approved April 15, 1993. Published June 1993.

² Annual Book of ASTM Standards, Vol 11.01.

³ Available from the American National Standards Institute, 11 W. 42nd Street, 13th Floor, New York, NY 10036.

⁴ Laenen, A., and Smith, W., "Acoustic Systems for the Measurement of Streamflow," *U.S. Geological Survey Water Supply Paper 2213*, 1983.

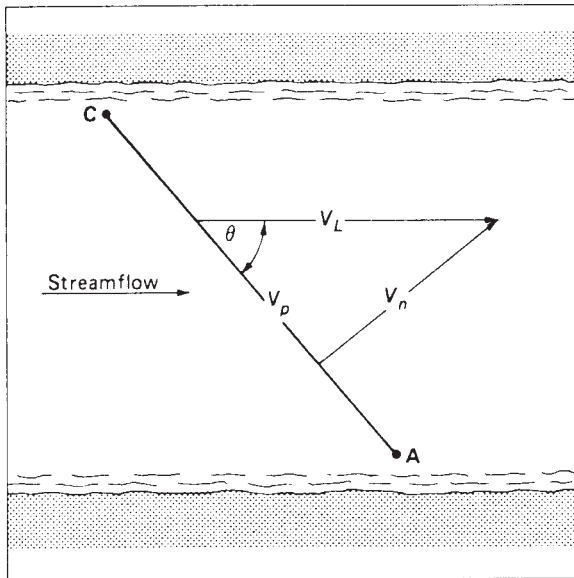

FIG. 1 Velocity Component Used in Developing Travel-Time Equations

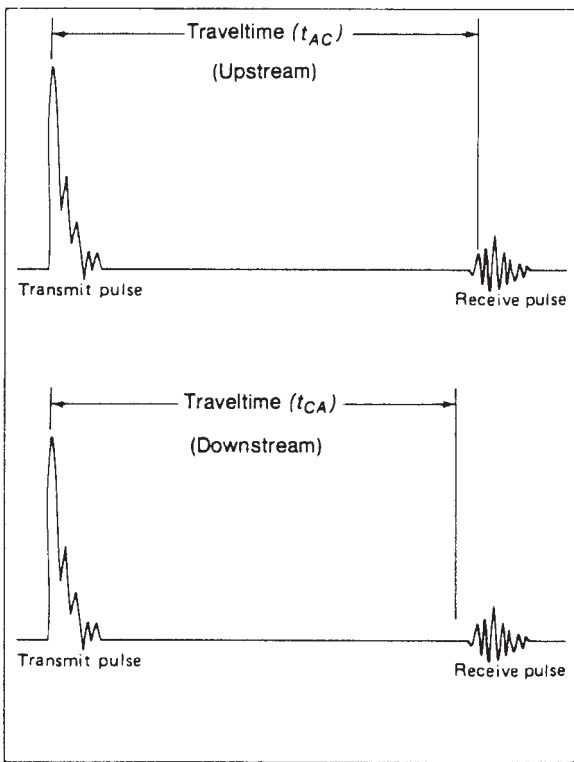

FIG. 2 Voltage Representation of Transmit and Receive Pulses at Upstream and Downstream Transducers

where:

- V_L = line velocity, or the average water velocity at the depth of the acoustic path,
- θ = angle of departure between streamflow and the acoustic path,
- t_{AC} = traveltime from A to C (upstream),
- t_{CA} = traveltime from C to A (downstream), and
- B = length of the acoustic path from A to C.

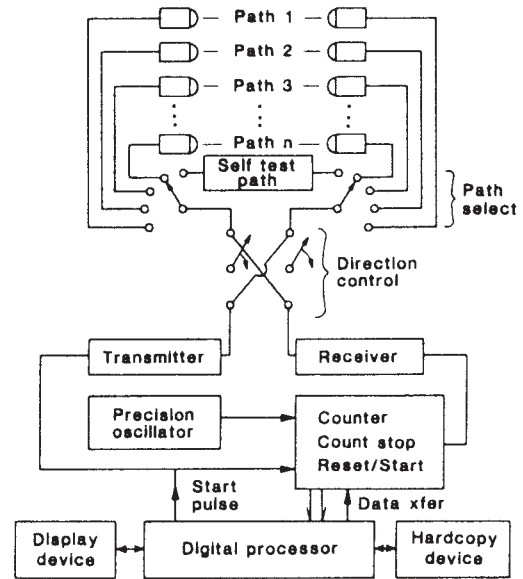
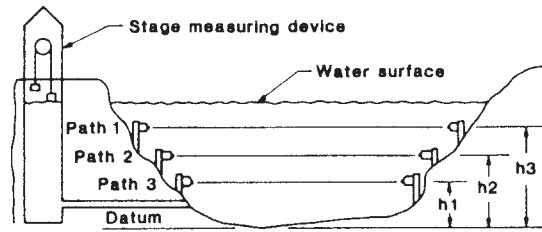

FIG. 3 Example of Acoustic Velocity/Flow Measuring System

4.3 The discharge measurement or volume flow rate determination made with an AVM relies on a calibrated or theoretical relation between the line velocity as measured by the AVM and mean velocity in the flow segment being measured. Taking more line velocity measurements across the channel at different elevations in the acoustic plane and performing a numerical integration or weighted summation of the measured velocities and areas of flow can be used to better define the volume flow rate. The spacing between acoustic paths, the spacing between the top path and the liquid surface, and the spacing between the lowest path and the bottom are determined on the basis of stream cross-section geometry or estimates of the vertical-velocity distribution and by the required measurement accuracy. In addition to several line velocity measurements, it is necessary to provide water level (stage) and cross-sectional area information for calculation of the volume flow rate (see Fig. 3).

5. Significance and Use

5.1 This test method is used where high accuracy of velocity or continuous discharge measurement over a long period of time is required and other test methods of measurement are not feasible due to low velocities in the channel, variable stage-discharge relations, complex stage-discharge relations, or the presence of marine traffic. It has the additional advantages of requiring no moving parts, introducing no head loss, and providing virtually instantaneous readings (1 to 100 readings per second).

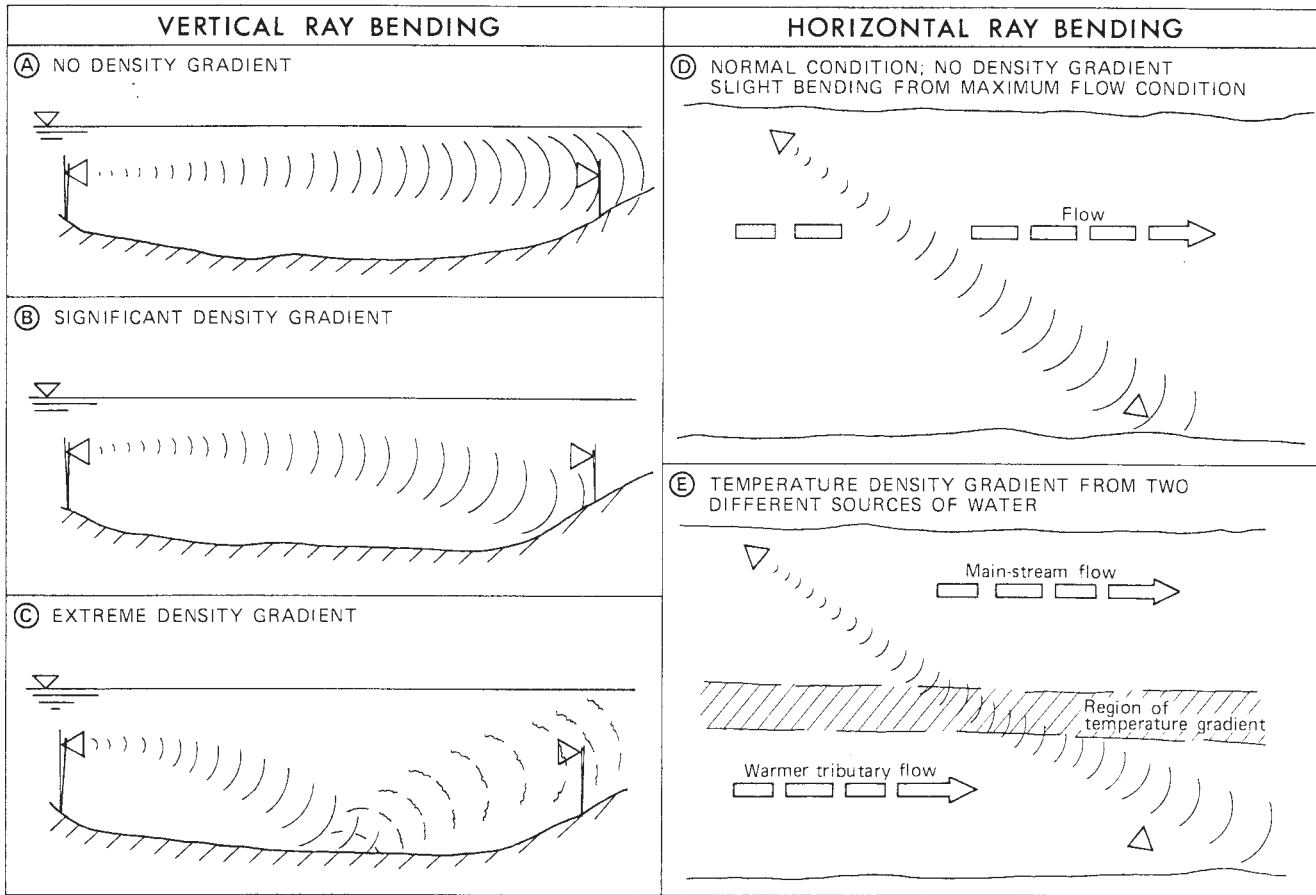

FIG. 4 Signal Bending Caused by Different Density Gradients⁴

5.2 The test method may require a relatively large amount of site work and survey effort and is therefore most suitable for permanent or semi-permanent installations.

6. Interferences

6.1 *Refraction*—The path taken by an acoustic signal will be bent if the medium through which it is propagating varies significantly in temperature or density. This condition, known as ray bending, is most severe in slow moving streams with poor vertical mixing or tidal (estuaries) with variable salinity. In extreme conditions the signal may be lost. Examples of ray bending are shown in Fig. 4. Beam deflection for various temperatures and specific conductivities are shown in Fig. 5 and Fig. 6.

6.2 *Reflection*—Acoustic signals may be reflected by the water surface or streambed. Reflected signals can interfere with, or cancel, signals propagated along the measurement plane. When thermal or density gradients are present, the placement of transducers with respect to boundaries is most critical. This condition is most critical in shallow streams. A general rule of thumb to prevent reflection interference is to maintain a minimum stream depth to path length ratio of 1 to 100 for path lengths greater than 50 m.

6.3 *Attenuation*—Acoustic signals are attenuated by absorption, spreading, or scattering. Absorption involves the conversion of acoustic energy into heat. Spreading loss is signal weakening as it spreads outward geometrically from its source.

Scattering losses are the dominant attenuation factors in streamflow applications. These losses are caused by air bubbles, sediment, or other particle or aquatic materials present in the water column. Table 1 presents tolerable sediment concentrations.

6.4 *Mechanical Obstructions*—Marine growth or water-borne debris may build up on transducers or weed growth, boats, or other channel obstructions may degrade propagation and timing of acoustic signals.

6.5 *Electrical Obstructions*—Nearby radio transmitters, electrical machinery, faulty electrical insulators, or other sources of electromagnetic interference (EMI) can cause failure or sporadic operation of AVMs.

7. Apparatus

7.1 The instrumentation used to measure open-channel flow by acoustic means consists of a complex and integrated electronic system known as an acoustic velocity meter (AVM). Three or four companies presently market AVM systems suitable for measurement of open-channel flow. System configurations range from simple single-path to complex-multi-path systems. Internal computation, transmission, and recording systems vary depending on local requirements. Most AVM systems must include the capability to compute an acoustic line velocity from one or more path velocities together with stage (water level) and other information related to channel geometry

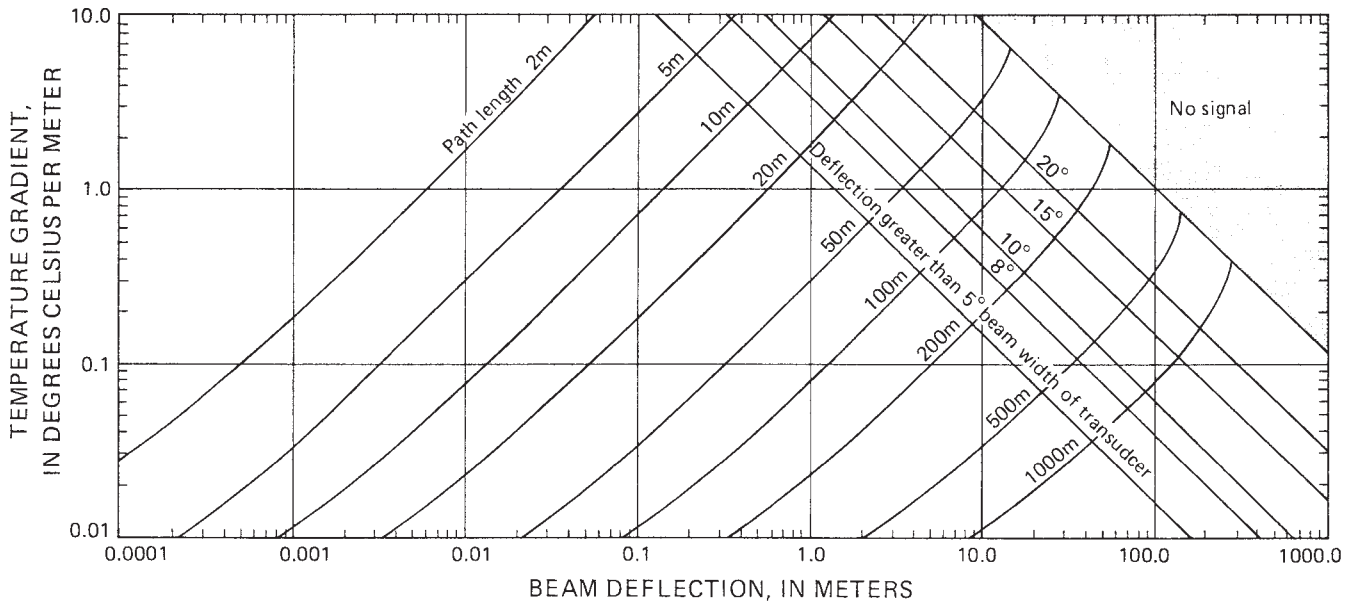

NOTE 1—Transducer directivity or beam width determined at the 30-dB level of the transmitted signal pattern. The signal is propagated beyond the beam width but at a weak level. In the shaded area the detection is so great that signals cannot be received directly for any transducer beam width.

FIG. 5 Beam Deflection From Linear Temperature Gradients for Different Path Lengths

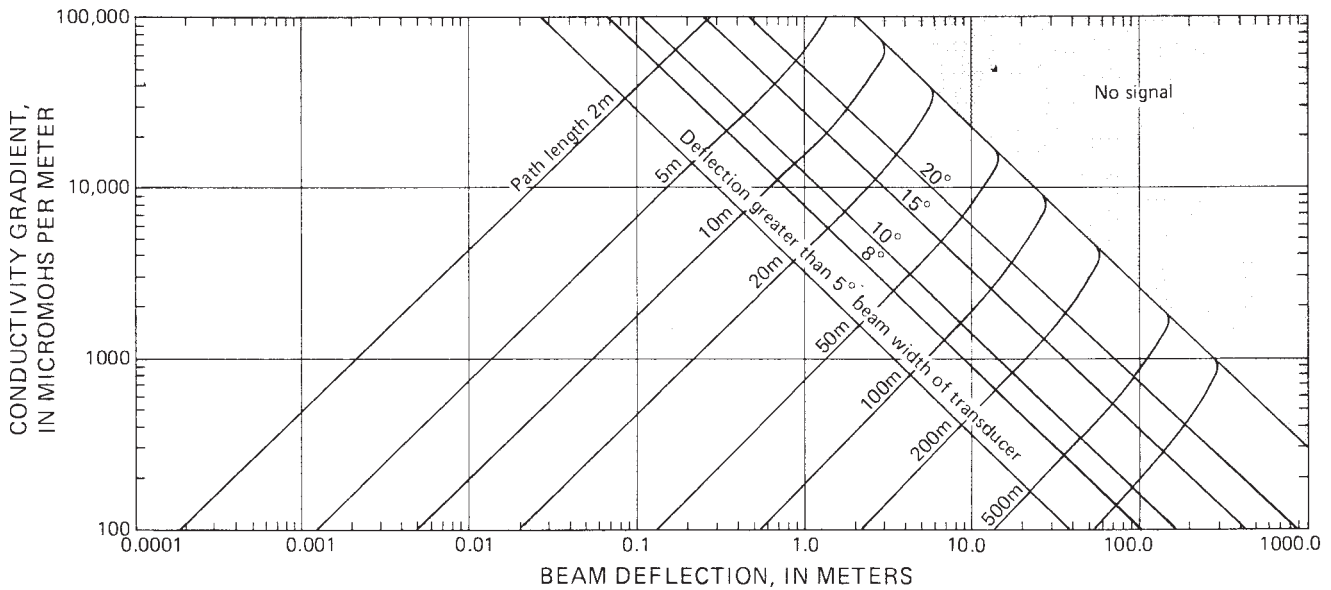

NOTE 1—Transducer directivity or beam width determined at the 30-dB level of the transmitted signal pattern. The signal is propagated beyond the beam width but at a weak level. In the shaded area the deflection is so great that signals cannot be received directly for any transducer beam width.

FIG. 6 Beam Deflection From Linear Conductivity Gradients for Different Path Lengths

necessary to calculate a flow rate per unit of time, usually cubic millimetres per second (m^3/s) or cubic feet per second (ft^3/s).

7.1.1 *Electronics Equipment*—There are several methods that are currently being used to implement the electro-acoustic functions and mathematical manipulations required to obtain a line-velocity measurement. Whatever method is used must include internal automatic means for continuously checking the accuracy. In addition, provision must be included to prevent erroneous readings during acoustic interruptions caused by river traffic, aquatic life, or gradual degradation of components.

7.1.2 *Flow Readout Equipment*—This equipment is functionally separated into three subsystems. These subsystems may or may not be physically separable but are discussed separately for clarity.

7.1.3 *Acoustic Tranceiver*—This system generates, receives, and measures the traveltimes of acoustic signals. The acoustic signals travel between the various pairs of acoustic transducers and form the acoustic paths from which line velocities are determined.

TABLE 1 Estimates of Tolerable Sediment Concentrations for AVM System Operation Based on Attenuation From Spherical Spreading and From Scattering From the Most Critical Particle Size

NOTE 1—Sediment concentrations in milligrams per litre.

Selected Transducer Frequency (kHz)	Path distance (m)							
	5	20	50	100	200	300	500	1000
1000	6300	1200	400	—	—	—	—	—
500	—	3500	1200	530	230	—	—	—
300	—	7900	2800	1300	560	350	—	—
200	—	11 000	4000	1800	830	520	280	—
100	—	—	10 000	4600	2200	1400	770	350
30	—	—	—	—	8800	5700	3200	1500

7.1.4 *Processor*—The processor performs the mathematical operations required to calculate acoustic line velocities, makes decisions about which acoustic paths should be used on the basis of stage, performs error checking, calculates total volume flow rate, and totalizes volume flow.

7.1.5 *Display/Recorder*—Generally, the output of the system is a display or a recorder, or both. The recorder normally includes calendar data, time, flow rate, stage, and any other information deemed desirable, such as error messages. Equipment of this type is often connected to other output devices, such as telemetry equipment.

7.2 *Acoustic Transducers*—Transducers may be active (containing Transmitter and first stage of amplification) or passive (no amplification) depending on path length and presence of electromagnetic interference EMI. Acoustic transducers must be rigidly mounted in the channel wall or bottom. Means must be provided for precise determination of acoustic path elevation, length, and angle to flow. The transducers and cabling must be sufficiently rugged to withstand the handling and operational environment into which they will be placed. Additionally, provision shall be made for simple replacement of transducer or cable, or both, in the event of failure or damage.

7.3 *Stage Measuring Device*—There are several methods for measuring stage and inputting this information to the system. The actual method used depends on the particular installation requirements. Some examples include visual measurement/manual keyboard entry, float/counterweight or bubbler systems with servo manometers connected to analog conversion equipment or digital encoders, upward looking acoustic transducers, or other electronic pressure sensors.

7.4 *Power Supply*—Several vendors currently offer battery-powered AVMs as well as systems operating on 110 V ac standard commercial electric power. Availability of electricity should be considered during site evaluation prior to equipment selection.

7.5 *Cabling*—All interconnected cabling to and from transducers shall be armored or protected, or both, to minimize damage during installation and operation.

7.6 *Responders*—A responder is an electronic device that receives an acoustic signal and then retransmits it back across the stream after a predetermined time interval. A responder is used where direct wire connection is impractical. A typical responder system is shown in Fig. 7

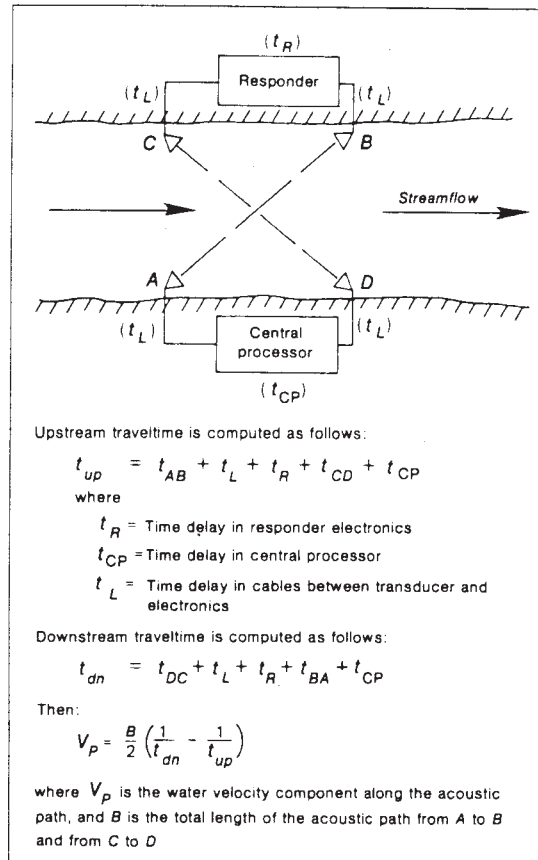

FIG. 7 Responder System

8. Sampling

8.1 Sampling, as defined in Terminology D 1129, is not applicable to this test method.

9. Preparation of Apparatus

9.1 Site Selections:

9.1.1 *Channel Geometry*—The gaged site should be in a section of channel that is straight for three to ten channel widths upstream and one to two channel widths downstream. The banks should be parallel and not subject to overflow. There should be minimal change in cross-section area between the upstream and downstream transducer locations. Calibrating discharge measurements must be made along the acoustic path where large differences exist in cross-sectional area between the upstream and downstream transducers. AVMs are not usually suitable for wide shallow channels, except by using multiple horizontal paths.

9.1.2 *Channel Stability*—The cross sections should not be subject to frequent shifting and the relationship between stage and cross-section area must be stable or frequently measured. Sites with unstable vertical velocity profiles should be avoided, or additional acoustic paths added within the vertical to obtain improved velocity averaging.

9.1.3 *Water Temperature Gradients*—Refraction of the acoustic signal is caused by temperature gradients in the water, and signal loss and resulting loss of accuracy may result. Channel reaches that maintain deep water during low-flow

periods (with consequent low mean velocities) may suffer from this problem during periods of high insolation.

9.1.4 Water Density Effects—Problems may be encountered at sites subject to the periodic intrusion of saline or brackish water, or where waters of differing density arising from other causes may be encountered. The effects will be similar to those associated with water temperature gradients. The key factor here is the periodic nature of the intrusion. The AVM techniques are not precluded from use in brackish or saline waters but, if a density interface is present at the gage location, signal loss due to refraction or reflection may occur. In wide estuaries, brackish water intrusions may cause cross-gradients and in such situations, time may need to be allowed for the flow to stabilize before measurements can be taken.

9.1.5 Sediment Load—The presence of suspended solids in the water may have a significant effect upon signal attenuation, causing both reflection and scatter. Signal loss from high sediment concentration is highly dependent on path length and transducer frequency, as shown in Table 1. At locations where concentrations greater than 1000 mg/L may be experienced for significant periods, or where reliable measurements is particularly important under such conditions, the ultrasonic technique may not be suitable.

9.1.6 Weed Growth—The gage cross section should be free of weed growth, that seriously attenuates the acoustic signal. Different types of weed may have different properties, because it is the air included within the plant structure that produces the unwanted effect.

9.1.7 Entrained Air—The presence of significant amounts of entrained air bubbles in the water may cause problems due to reflection and scattering of the propagated acoustic wave. Locations that are downstream of dams, weirs, waterfalls, or mill or power plant tail-races may suffer from this problem. Air entrainment from these hydraulic structures may persist for several kilometers downstream or 5 to 10 min from the source.

9.1.8 Remotely-Generated Hydraulic Effects—Hydraulic uniformity of a gage site is an important attribute. Velocity profiles that depart significantly from the ideal may be engendered by bed, bank, or tributary confluence conditions at locations remote from the gage location itself, but may persist to have an effect at the gage. They may be present during some river-flow states, but not during others. Locations close to tributary streams having hydrological regimes different from those of the main stream should be avoided.

9.1.9 Tributary Effects—The ultrasonic technique works most reliably where the physical properties of the water in the channel reach to be gaged are as nearly homogeneous as possible. In situations where an upstream tributary is injecting water of a significantly different physical character, difficulties may result. Usually these differences will be in the water temperature or suspended sediment load. Full mixing of the two bodies of water to a homogeneous state may not be achieved for a considerable distance downstream of the confluence.

9.1.10 Ambient Electrical Noise—The effective functioning of ultrasonic technique depends upon the reliability and sensitivity of electronic technology. Some instrumentation designs may suffer significantly from the effects of ambient electrical

TABLE 2 Possible Resolution Errors for Selected AVM Operating Frequencies and Path Lengths

Path Length (m)	Transducer Frequency (kHz)	Possible Error Using Multiple-Threshold Detection (m/s)	Possible Error Using Single-Threshold Detection (m/s)
1–5	1000	0.280–0.056	1.120–0.225
5–20	500	0.112–0.028	0.450–0.112
20–50	300	0.047–0.018	0.187–0.075
50–200	200	0.028–0.007	0.112–0.028
200–500	100	0.014–0.005	0.056–0.022
500–1000	30	0.018–0.009	0.075–0.037

noise (EMI), which may originate quite a distance away from the gage location. Powerful radio transmitters located many kilometres away from the gage may be a cause of difficulty. Most of these problems can be overcome by the use of active transducers, which greatly reduce the ratio of signal to noise on the transmission cabling.

9.2 Channel Environment, Width and Depth Constraints—In general, the transducer operating frequency used in a particular application depends on the acoustic path length, the minimum clearance between the acoustic path and adjacent acoustic reflectors (for example, surface and bottom), and the expected silt load or amount of entrained air, or both. If there were no sound absorption in water or spreading losses, the highest possible operating frequency would be used because this increases system timing accuracy and allows closer spacing between the acoustic path and the surface or bottom of the channel. However, sound absorption by water and scattering by particulate matter and entrained air increases with increasing frequency. Most systems operate at the upper limit of achievable power. A compromise must be reached that will provide sufficient system accuracy while at the same time sustain operating reliably under adverse absorption/scattering conditions. Table 2 provides rough ranges of frequencies and path lengths normally used in acoustic velocity measuring systems.⁵

9.3 Transducer-Mounting Requirements—When transducers are installed, it is necessary to determine and adjust the direction and elevations of each pair accurately, as well as the acoustic path lengths and the path angles. Transducer alignment is generally performed by moving the transducers (preferably from above the water surface) to maximize the received signals observed at the electronic equipment. Most systems have automatic gain control (AGC) circuitry; however, some systems require the use of an oscilloscope to view signal reception.

9.4 Supplemental Field Information—At the time of field installation, the following measurements must be made to support flow computations:

9.4.1 Determine and record the path length and angle between transducers for all installed paths. Measure the elevations of all transducers referenced to a common gage datum,

9.4.2 Determine and record the zero of stage sensing devices to a common gage datum,

⁵ Laenen, A., "Acoustic Velocity Meter Systems," *U.S. Geological Survey Techniques of Water Resources Investigations Book 3*, Chapter A17.

9.4.3 Determine and record the cross-sectional area at each transducer location for computation of stage-area relation,

9.4.4 Determine and record relevant site and equipment information to develop a station description for the gaging station, and

9.4.5 Determine and record any temperature or density gradients that may be present.

10. Calibration

10.1 *Single-Path Systems*—Calibrate with current-meter measurements (see Test Method D 3850) to establish the relation between line velocity and mean velocity for the range of stages present at a site. Conduct periodic checks to ensure that the relation remains stable.

10.2 *Multi-Path Systems*—Multi-path and single-path systems are both direct measuring systems if path angles and lengths are known. Multiple paths can be vertically or horizontally placed, or both. Multi-path systems, for paths placed vertically above one another, define the vertical velocity distribution and may require minimal calibration. If the paths provided in the system design are sufficiently numerous, there may be no need for calibration. However, calibration verification by current-meter measurements (see Test Method D 3850) will provide additional confidence in AVM data. Use multiple horizontal paths to minimize ray-bending in wide shallow streams, and frequent calibration by current-meter measurement is usually necessary.

NOTE 1—The use of a portable acoustic current meter is useful in calibrating AVMs. These meters have a high degree of low-velocity accuracy and the ability to measure the magnitude and direction of a point velocity. Particularly in a tidal-affected stream, the current direction will vary from lower to higher depths in the vertical. Under these conditions, the acoustic meter will improve the calibration accuracy.

11. Procedure

11.1 Properly install and calibrate the equipment. Follow procedures in the manufacturers operation manuals. Review data at least monthly to determine satisfactory system operation. Procedure does not have a specific requirement, but provide operational checks, calibration, and repair as required to maintain the systems.

12. Calculation

12.1 *Computation of Discharge*—Hydrologic data recorded are stage (h) and the average velocity along the acoustic path (v_p). Correlate these parameters to the geometric and hydraulic conditions at the gaged site in order to define the basic-flow equation:

$$Q = A\bar{V} \tag{2}$$

where:

- Q = discharge,
- A = area of the cross section, and
- \bar{V} = mean velocity of the cross section.

12.1.1 *Relation of Area and Stage*—The relation between area and stage can be adequately defined by a second-order polynomial equation:

$$A = C_1 + C_2h + C_3h^2 \tag{3}$$

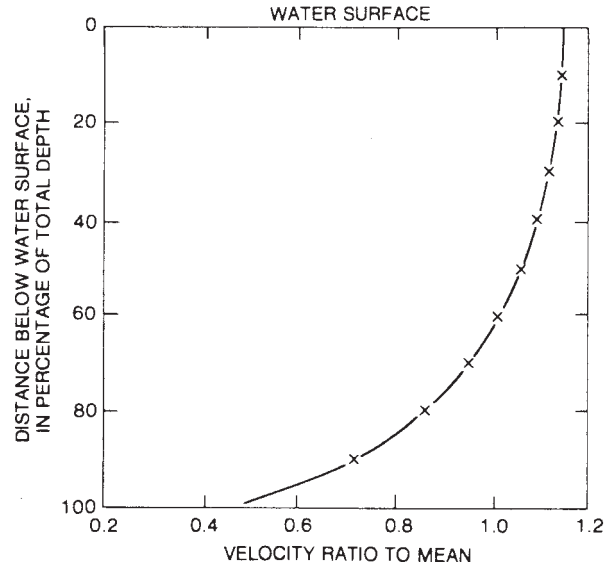

FIG. 8 Theoretical Vertical Velocity Distribution⁶

where C_1 , C_2 , and C_3 are constants that can be evaluated from data obtained during conventional current-meter measurements, or a cross-section survey, and h is stage. Some instruments store stage cross-sectional relations internally in various formats.

12.1.2 *Relation Between Path Velocity and Mean Cross-Section Velocity*—Determine the relation between the AVM path velocity and the mean in the cross section several methods depending on individual system configuration and channel conditions.

12.1.2.1 For a single- or cross path system, where channel conditions permit a reliable discharge measurement to be made (see Test Method D 3858) a relation of AVM path velocity to average stream velocity can be made for a series of measurements at various flow rates (see Fig. 8):⁶

$$K = \frac{\bar{V}}{V_p} \tag{4}$$

where:

- K = a ratio of path velocity to average velocity, and
- V_p = velocity in the acoustic path, adjusted from line velocity measured by AVM $V_p = V_{line} \cos \theta$.

12.1.2.2 For single- or cross-path systems, where reliable current-meter measurements cannot be made, the AVM can be used to define the average vertical velocity distribution in the cross section. Temporarily install a set of transducers at a series of discrete elevations in the water column and use them to determine the average velocity with respect to the path velocity. Compute K for different stages.

12.1.2.3 Where multiple path systems are used, averaging of the individual line velocities usually provides a good approximation of average stream velocities. In some systems it may be necessary to average these values and compute a K value as described in 12.1.2.1 or 12.1.2.2.

⁶ Buchanan, T. J., and Somers, W. P., "Discharge Measurements at Gaging Stations," *U.S. Geological Survey Techniques of Water-Resources Investigations, Book 3, Chapter A8.*

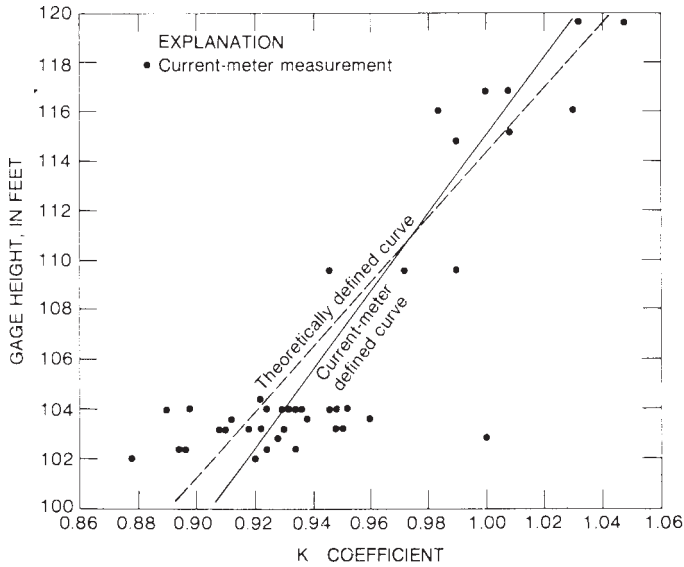

FIG. 9 Typical Velocity to Line Velocity Relation (K) for Various Stages⁴

12.1.2.4 Where an adequate number of discharge measurements have not or could not be made or other described methods are not possible, compute a good approximation of path velocity to mean cross-section velocity. Eq 5 approximates a horizontal-velocity distribution by assuming it will vary proportionately with the depth of flow in the cross section:

$$K = \frac{1}{A} \sum_{i=1}^n \frac{a_i}{0.1948 l_n \left(423.7 \frac{y_i}{d_i} \right)^9} \quad (5)$$

where:

- A = total cross-section area,
- a_i = incremental area,
- y_i = incremental distance above the streambed, and
- d_i = incremental total depth.

Fig. 9 shows typical K values from theoretically and current-meter measurement defined curves for various stages⁴.

12.1.2.5 Use multiple linear regression techniques to develop the relation of \bar{V} to V_p , where \bar{V} is the dependent and V_p the independent variable. This procedure is applicable in all cases, especially for a complex stage-discharge condition such as a tidal-affected stream. If other parameters are thought to have an influence on \bar{V} , it may be included in the regression, and tested for its level of significance.

13. Accuracy, Limitations, and Errors

13.1 Accuracy is affected by several factors (see Table 3). These are treated separately below:

13.1.1 *Timing Accuracy*—Timing accuracy is dependent on received signal-to-noise ratio, operating frequency, time-base accuracy, and time-base frequency, as shown in Table 3.

13.1.1.1 In general, signal-to-noise ratio and operating frequency are made as high as possible consistent with the propagation environment.

13.1.1.2 The time interval or pulse repetition frequency measurement is normally performed by a digital counter and crystal oscillator. Long-term stability of crystal oscillators are

TABLE 3 Error Sources

Path Length, m	Nominal Path Angle, °	% Velocity Error ^A	Velocity Error, m/s for Timing Uncertainty of:		
			±1 μs	±0.1 μs	±0.025 μs
300	30	1	0.008
	45	1.7	0.011
	60	3	0.014
100	30	1	0.025
	45	1.7	0.033	0.003	...
	60	3	0.043	0.004	...
30	30	1	0.08	0.008	...
	45	1.7	0.11	0.011	...
	60	3	0.14	0.014	...
10	30	1	0.25	0.025	...
	45	1.7	0.33	0.033	0.008
	60	3	0.43	0.043	0.011
3	30	1	0.8	0.06	0.014
	45	1.7	1.1	0.11	0.025
	60	3	1.4	0.14	0.033
1	30	1	2.5	0.25	0.043
	45	1.7	3.3	0.33	0.08
	60	3	4.3	0.43	0.11

^A Percent velocity error for 1° deviation between assumed and actual flow direction relative to acoustic path. This error results from uncertainty of both as-built path angle and unknown actual flow direction (streamline).

in the range from 10 to 50 ppm, errors from this source are therefore negligible. Short-term stability is in the 1-ppm range and is also negligible in its error contribution.

13.1.1.3 *Timing jitter* caused by the timing counting period constitutes a source of random error, as does noise on the received signal. However, both of these are random errors and are reduced as required by a suitable averaging period. Even with a 1000-ft (300 m) acoustic path, a single measurement can be made in less than 500 ms. Many individual measurements may easily be averaged together in a short period of time. For both ΔT and ΔF systems, longer averaging periods result in less reading to reading jitter in accordance with the well known $1/\sqrt{n}$ formula.

13.1.2 *Velocity of Sound Variations*—This does not constitute a significant source of error assuming sound velocity variations of less than 1% over the integration time of the acoustic path and that the velocity of the water is less than 15 m/s. The error from this source is usually less than 0.1%.

13.1.3 *Crossflow Errors*—This may be the largest potential source of errors for a single-path velocity measurement. Since the velocity component moving parallel to the acoustic path is proportional to the cosine of the angle between the assumed direction of flow and the acoustic path, a 1° error in assumed direction of flow or in the measurement of a 45° angle will result in a 1.76% error in line velocity measurement. This error increases as the path angle increases. If two crossed 45° paths are used and the outputs averaged, for practical purposes, this error is zero.

13.1.4 *Velocity Fluctuations*—Large-scale streamflow eddies introduce medium-term (10 to 300-s) random variations in the velocity readings. However, these variations can be averaged out over a suitable time interval that is long compared to the fluctuation period.

13.1.5 *Suspended Solids and Entrained Air*—Suspended materials will tend to reduce signal strength and may change the apparent velocity of sound. The main problem is to

minimize error due to excess or variable signal attenuation. This is accomplished as follows:

13.1.5.1 Use the lowest possible operating frequency consistent with other system requirements. This usually requires a tradeoff with timing accuracy for each installation before an operating frequency is chosen.

13.1.5.2 Use the highest possible transmitted power.

13.1.5.3 Use the optimal receiver gain possible within the constraints of ambient electrical or acoustic noise, or both.

13.1.5.4 Ensure that the receiver circuit is designed so that a signal that is sufficiently strong to meet the specified accuracy of measurement is used to compute velocity.

13.1.5.5 Receiver circuitry that employs AGC maintains similar levels of signal strength.

13.1.6 *Transducer Projection Into Flow*—There may be an error produced by the acoustic transducer or mounting cavity if it projects into the moving fluid streamlines. This error is generally less than the ratio of transducer diameter to path length, and can be corrected for if the streamline pattern past the transducer is known.

13.1.7 *Zero Stability*—Provision must be made to ensure continuous zero stability. This can be done either by using identical components for time measurement in each acoustic direction or by suitable electronic design to eliminate long-term electronic drift.

13.1.8 *Computational Error and Electronic Failures*—Computational errors can occur if the processor circuits malfunction. Means must be provided to automatically test timing and computational circuits as well as transmitter output and receiver sensitivity during system operation to ensure continuous accuracy.

13.1.9 *Path Length Error*—The computer line velocity is a function of the path length L . Therefore, errors in the assumed path length will directly affect the accuracy of the computed line velocity. A sensitivity test can be done by taking the water temperature and comparing the known velocity of sound in water for a given temperature with the AVM reading of velocity. The error in path length is proportional to the velocity of sound error.

13.1.10 *Signal Recognition Error*—Include means in the electronic/acoustic design to ensure that during operation only

those received acoustic signals that have sufficient amplitude and acceptable wave shape are used for time measurement.

13.1.11 *Non-Water Propagation Delay Errors*—These errors may result when measured travel times are not corrected for the time required by acoustic/electric signals to travel over cabling, through transducer acoustic window material, and through parts of the acoustic path that are stationary in water.

13.1.12 *Discontinuous Velocity Profile*—Discontinuous velocity profiles along an acoustic path can generate errors. However, in normal open-channel flow conditions, these are negligible.

13.1.13 *Path Deviation by Ray-Bending*—Temperature or density gradients change the mean velocity to path velocity relation by altering the location of the acoustic path between transducers. The error from ray-bending is variable and can be one of the largest potential sources in flow computation. Errors can be as great as $\pm 10\%$ before the system fails to operate because of ray-bending.

14. Precision and Bias

14.1 Open-channel multi-path acoustic flowmeters can be designed and installed to operate within an overall specified bias for known or assumed velocity distributions and water surface elevations. Bias of measurement can be improved appreciably by being able to optimize in the original planning and design, a system that can best accommodate problems identified in this test method.

14.2 System flow rate accuracies of 2% or better are achievable over a broad range of flow rates and channel conditions, if the system design avoids the main sources of error inherent in acoustic flowmeter installations. However, the accuracy can be confirmed only within the limits of the calibration method and program employed.

14.3 In accordance with 1.6 of Practice D 2777, an exemption to the precision and bias statement required by Practice D 2777 was recommended by the results advisor and concurred with by the Technical Operations Section of the Committee D-19 Executive Subcommittee on June 24, 1992.

15. Keywords

15.1 acoustic velocity meter; open channel flow; stream-flow; water discharge

ASTM International takes no position respecting the validity of any patent rights asserted in connection with any item mentioned in this standard. Users of this standard are expressly advised that determination of the validity of any such patent rights, and the risk of infringement of such rights, are entirely their own responsibility.

This standard is subject to revision at any time by the responsible technical committee and must be reviewed every five years and if not revised, either reapproved or withdrawn. Your comments are invited either for revision of this standard or for additional standards and should be addressed to ASTM International Headquarters. Your comments will receive careful consideration at a meeting of the responsible technical committee, which you may attend. If you feel that your comments have not received a fair hearing you should make your views known to the ASTM Committee on Standards, at the address shown below.

This standard is copyrighted by ASTM International, 100 Barr Harbor Drive, PO Box C700, West Conshohocken, PA 19428-2959, United States. Individual reprints (single or multiple copies) of this standard may be obtained by contacting ASTM at the above address or at 610-832-9585 (phone), 610-832-9555 (fax), or service@astm.org (e-mail); or through the ASTM website (www.astm.org).