



Designation: D 5640 – 95 (Reapproved 1999)

Standard Guide for Selection of Weirs and Flumes for Open-Channel Flow Measurement of Water¹

This standard is issued under the fixed designation D 5640; the number immediately following the designation indicates the year of original adoption or, in the case of revision, the year of last revision. A number in parentheses indicates the year of last reapproval. A superscript epsilon (ϵ) indicates an editorial change since the last revision or reapproval.

1. Scope

1.1 This guide covers recommendations for selection of weirs and flumes for the measurement of the volumetric flow rate of water and wastewater in open channels under a variety of field conditions.

1.2 This guide emphasizes the weirs and flumes for which ASTM standards are available, namely, thin-plate weirs, broad-crested weirs, Parshall flumes, and Palmer-Bowlus (and other long-throated) flumes. However, reference is also made to other measurement devices and methods that may be useful in specific situations.

1.3 *This standard does not purport to address all of the safety concerns, if any, associated with its use. It is the responsibility of the user of this standard to establish appropriate safety and health practices and determine the applicability of regulatory limitations prior to use.*

2. Referenced Documents

2.1 ASTM Standards:

- D 1129 Terminology Relating to Water²
- D 1941 Test Method for Open Channel Flow Measurement of Water with the Parshall Flume²
- D 3858 Test Method for Open-Channel Flow Measurement of Water by Velocity-Area Method²
- D 5242 Test Method for Open-Channel Flow Measurement of Water with Thin-Plate Weirs²
- D 5389 Test Method for Open-Channel Flow Measurement of Water by Acoustic Velocity Meter Systems²
- D 5390 Test Method for Open-Channel Flow Measurement of Water with Palmer-Bowlus Flume²
- D 5614 Test Method for Open-Channel Flow Measurement of Water with Broad-Crested Weirs²

2.2 ISO Standard:

- ISO 555-1973: Liquid Flow Measurement in Open Channels—Dilution Methods for Measurement of Steady Flow—Constant-Rate Injection Method³

¹ This guide is under the jurisdiction of ASTM Committee D-19 on Water and is the direct responsibility of Subcommittee D19.07 on Sediments, Geomorphology, and Open-Channel Flow.

Current edition approved April 15, 1995. Published June 1995.

² *Annual Book of ASTM Standards*, Vol 11.01.

³ Available from American National Standards Institute, 11 W. 42nd St., 13th Floor, New York, NY 10036.

3. Terminology

3.1 *Definitions*—For definitions of terms used in this guide, refer to Terminology D 1129.

3.2 Definitions of Terms Specific to This Standard:

3.2.1 *blackwater*—an increase in the depth of flow upstream of a channel obstruction, in this case a weir or flume.

3.2.2 *contracted weirs*—contractions of thin-plate weirs refer to the widths of weir plate between the notch and the sidewalls of the approach channel. In fully contracted weirs, the ratio of the notch area to the cross-sectional area of the approach channel is small enough for the shape of the channel to have little effect. In suppressed (full-width) rectangular weirs, the contractions are suppressed, and the weir crest extends the full width of the channel.

3.2.3 *crest*—in rectangular thin-plate weirs, the horizontal bottom of the overflow section; in broad-crested weirs and flumes, the plane, level floor of the flow section.

3.2.4 *critical flow*—open-channel flow in which the energy, expressed in terms of depth plus velocity head, is a minimum for a given flow rate and channel.

3.2.4.1 *Discussion*—The Froude number is unity at critical flow.

3.2.5 *Froude number*—a dimensionless number expressing the ratio of inertial to gravity forces in free-surface flow. It is equal to the average velocity divided by the square root of the product of the average depth and the acceleration due to gravity.

3.2.6 *head*—in this context, the depth of flow referenced to the crest of the weir or flume and measured at a specified location; this depth plus the velocity head are often termed the total head or total energy head.

3.2.7 *hydraulic jump*—an abrupt transition from supercritical to subcritical or tranquil flow, accompanied by considerable turbulence or gravity waves, or both.

3.2.8 *long-throated flume*—a flume in which the prismatic throat is long enough relative to the head for a region of essentially critical flow to develop on the crest.

3.2.9 *nappe*—the curved sheet or jet of water overfalling a weir.

3.2.10 *notch*—the overflow section of a triangular weir or of a rectangular weir with side contractions.

3.2.11 *primary instrument*—the device (in this case, a weir or flume) that creates a hydrodynamic condition that can be

sensed by the secondary instrument.

3.2.12 *rangeability*—the spread between the maximum, Q_{max} , and minimum, Q_{min} , flow rates that a measuring instrument can usefully and reliably accommodate; this may be described as the ratio Q_{max}/Q_{min} .

3.2.13 *secondary instrument*—in this case, a device that measures the head on the weir or flume; it may also convert this measured head to an indicated flowrate or could totalize the flow.

3.2.14 *subcritical flow*—open-channel flow that is deeper and at lower velocity than critical flow for the same flow rate; sometimes called tranquil flow.

3.2.14.1 *Discussion*—The Froude number is less than unity for this flow.

3.2.15 *submergence*—the ratio of downstream head to upstream head on a weir or flume. Submergence greater than a critical value affects the discharge for a given upstream head.

3.2.16 *supercritical flow*—open-channel flow that is shallower and at higher velocity than critical flow for the same flow rate.

3.2.16.1 *Discussion*—The Froude number is greater than unity for this flow.

3.2.17 *throat*—the constricted portion of a flume.

3.2.18 *velocity head*—the square of the average velocity divided by twice the acceleration due to gravity.

4. Significance and Use

4.1 Each type of weir and flume possesses advantages and disadvantages relative to the other types when it is considered for a specific application; consequently, the selection process often involves reaching a compromise among several features. This guide is intended to assist the user in making a selection that is hydraulically, structurally, and economically appropriate for the purpose.

4.2 It is recognized that not all open-channel situations are amenable to flow measurement by weirs and flumes and that in some cases, particularly in large streams, discharges may best be determined by other means. (See 6.2.2.)

5. Weirs and Flumes

5.1 Weirs:

5.1.1 Weirs are overflow structures of specified geometries for which the volumetric flow rate is a unique function of a single measured upstream head, the other elements in the head-discharge relation having been experimentally or analytically determined. Details of the individual weirs may be found in the ASTM standards cited as follows:

5.1.2 *Standard Weirs*— The following weirs, for which ASTM standards are available, are considered in this guide:

5.1.2.1 Thin-plate weirs (see Test Method D 5242).

(1) Rectangular weirs (see Fig. 1).

(2) Triangular (V-notch) weirs (see Fig. 2).

5.1.2.2 Broad-crested weirs (see Test Method D 5614).

(1) Square-edge (rectangular) weirs (see Fig. 3).

(2) Rounded-edge weirs (see Fig. 4).

5.1.3 The quantitative information on weirs presented in Figs. 1-4 is intended to give the user only an overview and assist in the preliminary assessments for selection. To that end, some approximations and omissions were necessary for the

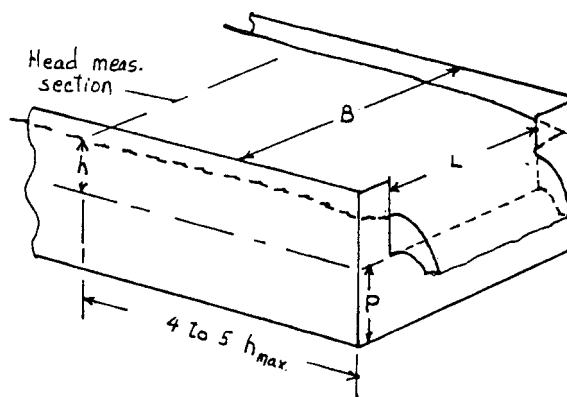

Limitations on geometry:^A $h/P \leq 2$
 $h \geq 0.1 \text{ ft (0.03 m)}$
 $L \geq 0.5 \text{ ft (0.15 m)}$
 $P \geq 0.3 \text{ ft (0.1 m)}$

Approximate discharge equation, for selection purposes only:^B

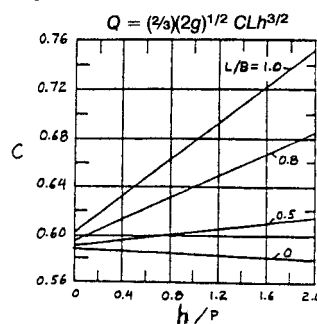

^A These limitations are for partially contracted weirs. See Test Method D 5242 for conditions on fully contracted weirs.

^B See Test Method D 5242 for more accurate standard equations. In compatible units, Q is flow rate, ft³/s (m³/s); g is acceleration due to gravity, ft/s² (m/s²); h is head in ft. (m); C is coefficient shown in Fig. 1.

FIG. 1 Rectangular Thin-Plate Weirs

sake of brevity and convenience, and the published standards must be consulted for exact and complete information on requirements, conditions, and equations.

5.2 Flumes:

5.2.1 Flumes use sidewall constrictions or bottom shapes or slopes of specified geometries, or both, to cause the flow to pass through the critical condition; this permits determination of the flow rate from a measured head and a head-discharge relation that has been experimentally or analytically obtained. Details of the individual flumes may be found in the ASTM standards cited as follows:

5.2.2 *Standard Flumes*— The following flumes, for which ASTM standards are available, are emphasized in this guide. Other flumes, which may be useful in specific situations, are cited in 5.2.4.

5.2.2.1 Parshall flumes (see Test Method D 1941, Fig. 5, and Table 1).

5.2.2.2 Palmer-Bowlus (and other long-throated) flumes (see Test Method D 5390 and Fig. 6).

5.2.3 The quantitative information on flumes presented in Fig. 5 and Fig. 6 is intended to give the user only an overview and assist in the preliminary assessments for selection. To that end, some approximations and omissions were necessary for the sake of brevity and convenience, and the published

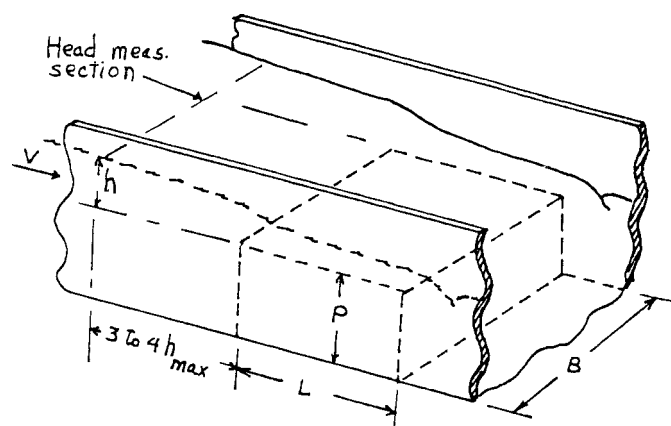
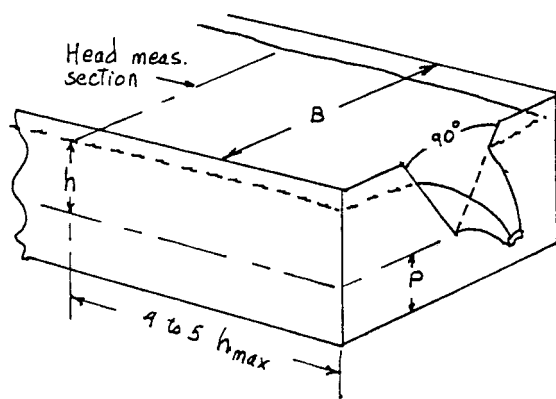

Limitations on geometry:^B

- $h/P \leq 1.2$
- $h/B \leq 0.4$
- $P \geq 0.3 \text{ ft (0.1 m)}$
- $B \geq 2 \text{ ft (0.6 m)}$
- $0.15 \text{ ft (0.05 m)} \leq h \leq 2 \text{ ft (0.6 m)}$

Approximate discharge equation, for selection purposes only:^C

$$C = (0.15)C(2g)^{1/2} (\tan \theta/2)h^{5/2}$$

^A A 90° notch is shown; information is also available on notch angles from 20 to 100; see Test Method D 5242.

^B These limits pertain to partially contracted 90° notches only. See Test Method D 5242 for other notch angles and full contractions.

^C C is approximately 0.58. See Test Method D 5242 for more accurate values of C and for the complete standard equation. Here θ is the notch angle, and the other terms are as described in footnote B of Fig. 1.

FIG. 2 Triangular Thin-Plate Weir^A

standards must be consulted for exact and complete information on requirements, conditions, and equations.

5.2.4 Other Flumes—The following flumes are not covered by ASTM standards but are listed here because they were developed for specific situations that may be of interest to users of this guide. Detailed information on them can be found in the reference section.

5.2.4.1 H-Series Flumes (1), (2)—This flume, which was developed for use on agricultural watersheds, is actually a combination of flume and triangular weir and consequently exhibits very high rangeability along with good sediment transport capability.

5.2.4.2 Portable Parshall Flume (1)—This 3-in. (7.6-cm) flume closely resembles the 3-in. standard Parshall flume with the downstream divergent section removed. Its small size makes it convenient to transport and install in some low-flow field applications.

5.2.4.3 Supercritical-Flow Flumes (1)—These flumes were developed for use in streams with heavy loads of coarse sediment. The depth measurement is made in the supercritical-flow portion of the flume rather than upstream.

6. Selection Criteria

6.1 Accuracy:

6.1.1 The error of a flow-rate measurement results from a combination of individual errors, including errors in the coefficients of the head-discharge relations; errors in the measurement of the head; and errors due to nonstandard shape or installation or other departures from the practices recommended in the various weir or flume standards, or both. This guide considers the accuracy of the primary devices only,

Limitations on geometry:^A

- $h \geq 0.2 \text{ ft (0.06 m)}$
- $b \geq 1.0 \text{ ft (0.3 m)}$
- $P \geq 0.5 \text{ ft (0.15 m)}$
- $0.1 < L/P < 4$
- $0.1 < h/L < 1.6$
- $h/P < 1.6$

Discharge equation:^B $Q = (2/3)^{3/2}(g)^{1/2} CBh^{3/2}$

Approximate C, for selection purposes only^C

h/P	h/L			
	0.2	0.6	1.0	1.6
0.1	0.85	0.88	0.97	(1.11)
0.5	0.88	0.91	1.01	1.15
1.0	(0.93)	0.96	1.06	1.19
1.5	(0.96)	1.02	1.11	1.24

^A See Test Method D 5390 for upstream transitions, allowable downstream-to-upstream head ratios, and other requirements.

^B Q, g, and h as described in Fig. 1, Footnote B.

^C See Test Method D 5390 for complete table; figures in parentheses are outside of the recommended geometric limits.

FIG. 3 Rectangular (Square-Edge) Broad-Crested Weirs

based on their accuracy potential under optimum or standard conditions; from information included in the individual standards, users can estimate secondary-system errors and other errors to obtain an estimate of the total measurement error.

6.1.2 The errors inherent in the basic head-discharge relations of the primary devices are as follows:

6.1.2.1 Thin-Plate weirs:

- (1) Triangular, fully contracted, ± 1 to 2 %.
- (2) 90° notch, partially contracted, ± 2 to 3 %.
- (3) Rectangular, fully contracted, ± 1 to 2 %.
- (4) Rectangular, partially contracted, ± 2 to 3 %.

6.1.2.2 Broad-crested weirs:

- (1) Square-edge, ± 3 to 5 % (depending on head-to-weir height ratio).
- (2) Rounded, ± 3 % (in the optimum range of head-to-length ratio).

6.1.2.3 Flumes:

- (1) Parshall flumes, ± 5 %.
- (2) Palmer Bowlus and long-throated flumes, ± 3 to 5 % (depending on head-to-length ratio).

6.1.2.4 This listing indicates that, with no consideration of other selection criteria, thin-plate weirs are potentially the most accurate of the devices.

6.1.3 Sensitivity—The discharge of weirs and flumes depends upon the measured head to the three-halves power for rectangular control sections (this is an approximation in the

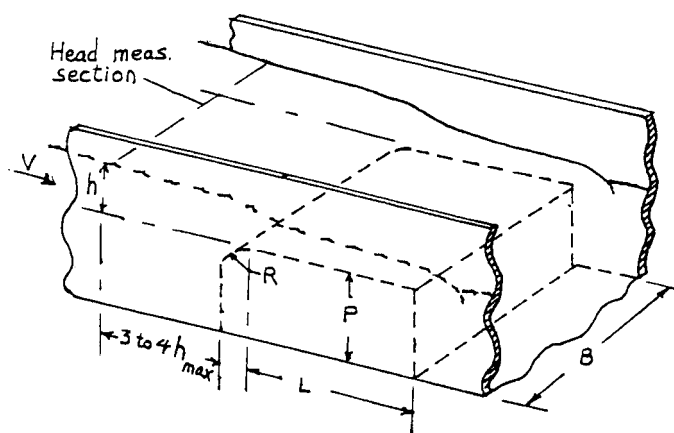

Limitations on geometry:^A

- $h \geq 0.2 \text{ ft. (0.06 m)}$
- $R \geq 0.2 h_{\text{max}}$
- $L \geq 1.75 h_{\text{max}}; L + R \geq 2.25 h_{\text{max}}$
- $0.05 \leq H/L \leq 0.57 \text{ (} H = h + V^2/2g \text{)}$
- $P \geq 0.5 \text{ ft. (0.15 m)}$
- $H/P < 1.5$
- $B \geq 1 \text{ ft. (0.3 m); } \geq H_{\text{max}}; \geq L/5$

Approximate discharge equation, for selection purposes only:^B

$$Q = 0.54 (g)^{1/2} C_d B H^{3/2} \text{ (} H = h + V^2/2g \text{)}$$

C_d varies from about 0.9 at lowest h/L and B/L to about 0.99 at highest h/L and B/L .

^A See Test Method D 5390 for upstream transitions, allowable downstream-to-upstream head ratios, and other requirements.

^B See Test Method D 5390 for standard equations, and determination of C_d , Q , g , and h are as described in Fig. 1, Footnote B.

FIG. 4 Rounded Broad-Crested Weirs

case of Parshall flumes), to the five-halves power for triangular sections, and to intermediate powers for intermediate trapezoidal sections. Consequently, the accuracy of a flow-rate measurement is sensitive to errors in head measurement and particularly so in the case of triangular control sections. It follows that in all weirs and flumes operating at or near minimum head, even a modest error or change in head can have a significant effect on the measured flow rate. Therefore, it is important to select sizes or combinations of devices that avoid prolonged operation near minimum head.

6.2 Flow rate:

6.2.1 This criterion includes the maximum anticipated flow rate and the range of flow rate from minimum to maximum. The latter consideration includes not only daily or seasonal variations but also a flow chronology in which, for example, an area under development generates an initially low waste-water discharge followed in subsequent years by increasing flow rates.

6.2.2 Flow capacities:

6.2.2.1 *Small and Moderate Flows*—Apart from considerations of head loss (6.3) and sediment or debris transport (6.4), thin-plate weirs are most suitable for lower flow rates, with the triangular notches most appropriate for the smallest flows. Small Parshall and Palmer-Bowlus flumes are also available for low flows; these improve on the thin-plate weirs in sediment passage and head loss but at some sacrifice of potential accuracy (6.1).

6.2.2.2 *Large Flows*—Large discharges are best measured with flumes and broad-crested weirs, which can accommodate large heads and flows and, given proper construction, are

inherently sturdy enough to withstand them. For example, the 50-ft (15.24-m) Parshall flume can be used for flow rates up to about 3200 ft³/s (90 m³/s). However, flumes and broad-crested weirs that are adequate for very large flows require major construction, and users may wish to consider establishing a measuring station (3), (4) with other methods of discharge measurement, for example, velocity-area method (Test Method D 3858), acoustic velocity meters (Test Method D 5389), or tracer dilution (ISO 555).

6.2.3 Range of Flow Rate:

6.2.3.1 Triangular thin-plate weirs have the largest rangeability of the standard devices because of their 2.5-power dependence on head. This rangeability can vary from slightly under 200 for fully contracted weirs to about 600 for partially contracted 90° notches that can utilize the allowable range of head.

6.2.3.2 For rectangular thin-plate weirs, the rangeability varies somewhat with the crest length-to-channel width ratio and is typically about 90, increasing to about 110 for full-width weirs. These results are based on a minimum head of 0.1 ft (0.03 m) and a suggested (although not absolute) maximum head of 2 ft (0.6 m). However, the rangeability of smaller rectangular weirs can be significantly less.

6.2.3.3 The rangeability of the rounded broad-crested weir is close to 40. However, large square-edge weirs, if used to the geometric limits of the standard, exhibit a rangeability of about 90.

6.2.3.4 The rangeability of Parshall flumes varies widely with size. (See Fig. 5 and Table 1.)

6.2.3.5 For Palmer-Bowlus and other long-throated flumes, the rangeability depends on the shape of the throat cross section, increasing as that shape varies from rectangular toward triangular. For the typical commercial Palmer-Bowlus flume of trapezoidal section, at least one manufacturer cites maximum-to-minimum flow-rate ratios up to, and in some cases exceeding, 100; (5) however, the head range is often beyond the recommendations of Test Method D 5390.

6.2.3.6 In cases in which there is a need for extreme rangeability along with sediment-transport capability, users may wish to consider the H-series flumes (5.2.4).

6.2.3.7 In cases in which low flows are expected to prevail for an extended period but will ultimately be superseded by much larger flow rates, users may wish to consider the interim use of removable small flumes nested inside larger ones.

6.3 Head Loss:

6.3.1 The upstream-to-downstream head difference that is required for the weir or flume to operate properly may be a selection criterion in many cases: for example, when sufficient elevation difference is not available to maintain the required flow, when the upstream channel cannot contain the backwater, or the reduced velocity in the backwater region causes excessive deposition of solids.

6.3.2 Some devices, notably the Parshall flume, can operate under partially submerged conditions with consequently reduced upstream-to-downstream head difference; however, this is done at the cost of reduced accuracy and an additional (downstream) head measurement.

6.3.3 For the same flow conditions, thin-plate weirs usually

ASTM D 5640

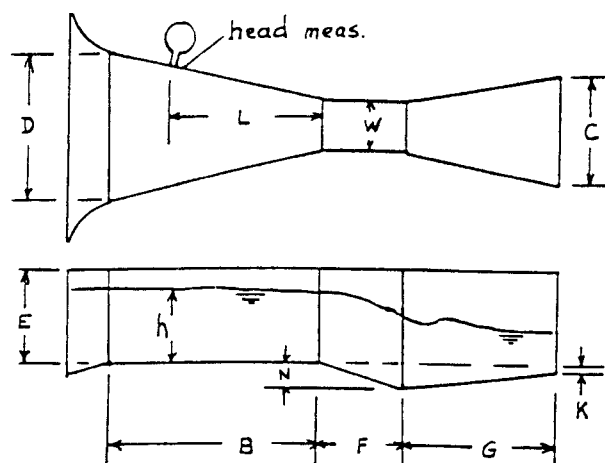

Geometry: Parshall flumes are designated by throat width, W ; Standard sizes and capacities are listed as follows:

Discharge equations: $^A Q = Ch^n$

Flume Size, W		C^B (Inch-Pound)	C^B (SI)	n	Maximum Q		Minimum Q	
ft-in.	cm				ft ³ /s	m ³ /s	ft ³ /s	m ³ /s
0-1	2.54	0.338	0.0479	1.55	0.19	0.0054	0.005	0.00014
0-2	5.08	0.676	0.0959	1.55	0.45	0.013	0.019	0.00054
0-3	7.62	0.972	0.141	1.55	1.60	0.045	0.028	0.00079
0-6	15.24	2.06	0.264	1.58	3.90	0.11	0.054	0.0015
0-9	22.86	3.07	0.393	1.53	8.90	0.25	0.09	0.0026
1-0	30.48	4.00	0.624	1.522	16.1	0.46	0.17	0.0034
1-6	45.72	6.00	0.887	1.538	24.6	0.88	0.17	0.0049
2-0	60.96	8.00	1.135	1.550	33.1	0.94	0.42	0.012
3-0	91.44	12.00	1.612	1.566	50.4	1.43	0.61	0.017
4-0	121.9	16.00	2.062	1.578	67.9	1.92	1.26	0.036
5-0	152.4	20.00	2.500	1.587	85.6	2.42	1.6	0.045
6-0	182.9	24.00	2.919	1.595	103.5	2.93	2.6	0.074
7-0	213.4	28.00	3.337	1.601	121.4	3.44	3.0	0.085
8-0	243.8	12.00	3.736	1.607	139.5	3.95	3.5	0.099
10-0	304.8	19.38	4.709	1.6	300	8.50	6	0.17
12-0	365.8	46.75	5.590	1.6	500	14.2	7	0.20
15-0	457.2	57.81	6.912	1.6	800	22.6	8	0.23
20-0	609.6	76.26	9.117	1.6	1340	37.9	11	0.31
25-0	762.0	94.69	11.32	1.6	1660	47.0	14	0.40
30-0	914.4	113.1	13.53	1.6	1890	56.4	16	0.45
40-0	1219.2	150.0	17.94	1.6	2640	74.8	22	0.62
50-0	1524.0	186.9	22.35	1.6	3280	92.9	27	0.76

^A Equation and table for free (unsubmerged) flow only. See Test Method D 1941 for conditions for free flow and submerged-flow discharge curves.

^B Use C (inch-pound) and h in feet for flowrate in cubic feet per second; use C (SI) and h in centimetres for flow rate in litres per second.

FIG. 5 Parshall Flumes (see also Table 1)

require the largest head difference, while long-throated flumes and rounded broad-crested weirs require the least. Parshall flumes are usually intermediate between these extremes, unless they are operated in the submerged regime.

6.4 Sediment and Debris:

6.4.1 Flumes are superior to weirs for use in flows with bed loads and coarse sediments. Finer sediments, even though they would not necessarily settle out upstream of a weir, may over time abrade the sharp edges of a thin-plate weir or the sharp corner of a rectangular broad-crested weir and thus affect the discharge coefficients.

6.4.2 When floating debris is present, the use of thin-plate weirs, particularly those with triangular notches, should be avoided.

6.4.3 In cases of exceptionally heavy loads of coarse sediment, users may wish to consider supercritical-flow flumes (5.2.4); H-series flumes (5.2.4.1) also exhibit good sediment passing behavior.

6.5 Construction Requirements:

6.5.1 This criterion takes into account the anticipated difficulty and expense of constructing and installing a weir or flume that meets standard specifications.

6.5.1.1 The Parshall flume is probably the most difficult to construct, owing primarily to its relatively complex shape. Also, the sharp downward slope of the throat may require some excavation of the channel floor. Because the Parshall flume is an empirical device, it is important to adhere closely to the prescribed dimensions (see also 6.5.2).

6.5.1.2 The difficulty in constructing thin-plate weirs arises from the strict requirements for fabrication of the notch edges; this difficulty can be expected to increase with weir size.

6.5.1.3 The shapes of the Palmer-Bowlus and other long-throated flumes are often moderately complex, although less so than those of the Parshall flume. However, their discharge coefficients can be obtained theoretically and consequently some departures from planned or prescribed dimensions can be

TABLE 1 Major (Approximate) Dimensions for Parshall Flumes (see also Fig. 5)^A

Flume Size, W	n		n		C		F		G		N		K		E		L		
	ft-in.	cm	ft	cm	ft	cm	ft	cm	ft	cm	ft	cm	ft	cm	ft	cm	ft	cm	ft
0-1	2.54	1.17	36	0.55	16.7	0.30	9.3	0.25	7.6	0.67	20.3	0.094	2.9	0.062	1.9	0.5-0.75	15-23	0.78	23.8
0-2	5.08	1.33	41	0.70	21.3	0.44	13.5	0.38	11.4	0.83	25.4	0.14	4.3	0.073	2.2	0.5-0.83	15-25	0.89	27.1
0-3	7.62	1.50	46	0.85	25.9	0.58	17.8	0.50	15.2	1.00	30.5	0.19	5.7	0.83	2.5	1.0-1.5	30-46	1.00	30.5
0-6	15.24	2.00	61	1.30	39.7	1.29	39.4	1.00	30.5	2.00	61.0	0.38	11.4	0.25	7.6	2.0	61	1.33	40.6
0-9	22.86	2.83	86	1.88	57.5	1.25	38.1	1.00	30.5	1.50	45.7	0.38	11.4	0.25	7.6	2.5	76	1.89	57.6
1-0	30.48	4.41	134	2.77	84	2.00	61	2.00	61.0	3.0	91	0.75	22.9	0.25	7.6	3.0	91	2.94	89.7
1-6	45.72	4.66	142	3.36	103	2.50	79	2.00	61.0	3.0	91	0.75	22.9	0.25	7.6	3.0	91	3.11	94.7
2-0	60.96	4.91	150	3.96	121	3.00	91	2.00	61.0	3.0	91	0.75	22.9	0.25	7.6	3.0	91	3.27	99.7
3-0	91.44	5.40	164	5.16	157	4.00	122	2.00	61.0	3.0	91	0.75	22.9	0.25	7.6	3.0	91	3.60	110
4-0	121.9	5.88	179	6.35	194	5.00	152	2.00	61.0	3.0	91	0.75	22.9	0.25	7.6	3.0	91	3.92	120
5-0	152.4	6.38	194	7.55	230	6.00	183	2.00	61.0	3.0	91	0.75	22.9	0.25	7.6	3.0	91	4.25	130
6-0	182.9	6.86	209	8.75	267	7.00	213	2.00	61.0	3.0	91	0.75	22.9	0.25	7.6	3.0	91	4.58	140
7-0	213.4	7.35	224	9.95	303	8.00	244	2.00	61.0	3.0	91	0.75	22.9	0.25	7.6	3.0	91	4.91	150
8-0	243.8	7.84	239	11.15	340	9.00	274	2.00	61.0	3.0	91	0.75	22.9	0.25	7.6	3.0	91	5.23	159
10-0	304.8	14.0	427	15.6	476	12.0	366	3.00	91.4	6.0	183	1.12	34.3	0.50	15.2	4.0	122	5.89	179
10-0	365.8	16.0	488	18.4	561	14.7	447	3.00	91.4	8.0	244	1.12	34.3	0.50	15.2	5.0	152	6.54	199
15-0	457.2	25.0	762	25.0	762	18.3	559	4.00	122	10.0	305	1.50	46.7	0.75	22.9	6.0	183	7.52	229
20-0	609.6	25.0	762	30.0	914	24.0	732	6.00	183	12.0	366	2.25	68.6	1.00	30.5	7.0	213	9.16	279
25-0	762.0	25.0	762	35.0	1067	29.3	894	6.00	183	13.0	396	2.25	68.6	1.00	30.5	7.0	213	10.79	329
30-0	914.4	26.0	792	40.4	1231	34.7	1057	6.00	183	14.0	427	2.25	68.6	1.00	30.5	7.0	213	12.43	379
40-0	1219.2	27.0	823	50.8	1548	45.3	1382	6.00	183	16.0	488	2.25	68.6	1.00	30.5	7.0	213	15.70	478
50-0	1524.0	27.0	823	60.8	1853	56.7	1727	6.00	183	20.0	610	2.25	68.6	1.00	30.5	7.0	213	18.97	578

^A For selection purposes only. See Test Method D 1941 for complete standard dimensions and for information on upstream wingwalls and on locations for additional head measurement for submerged flow.

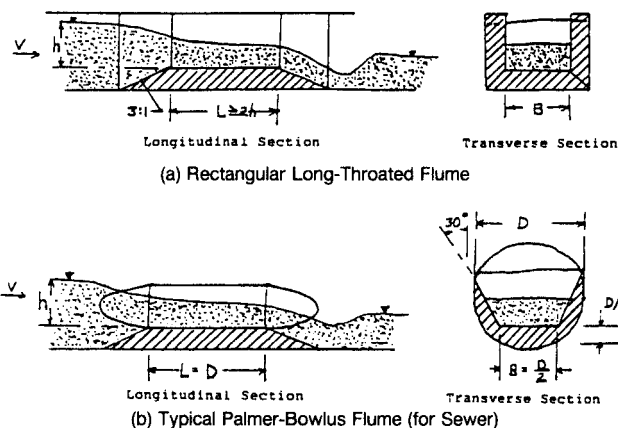

Limitations on geometry:^a
 $h \geq 0.15$ ft. (0.05 m)
 $0.1 \leq h/L \leq 0.5$
 $B \geq 0.33$ ft. (0.1 m)
 $h < 6$ ft. (2 m)

Approximate discharge equation, for selection purposes only:^b

$$Q = 0.54 (g)^{1/2} C_d C_s B H^{3/2}, \quad (H = h + V^2/2g)$$

C_d typically about 0.95; varies with viscous effects.
 C_s (rectangular throat) = 1.0

^a See D 5390 for details on location of head measurement, allowable downstream-to-upstream head ratios, and other requirements.

^b See D 5390 for complete standard equations and accurate determination of C_d and for variation of C_s with shape and head. Q , g , and h are as described in Fig. 1, footnote b.

FIG. 6 Palmer-Bowlus and Other Long-Throated Flumes

accommodated (see also 6.5.2).

6.5.1.4 Broad-crested weirs have relatively simple geometry and are in principle perhaps the easiest to construct, particularly when the existing channel is rectangular in cross section. The rounded broad-crested weir, like the longthroated flumes, can be analyzed theoretically; the squareedge weir, on the other hand, is empirical, and the square corner must be carefully fabricated and maintained.

6.5.2 The commercial availability of prefabricated Parshall

and Palmer-Bowlus flumes is noted here. Sizes up to several feet (metres) can be obtained, often in a form suitable for use in sewer lines; the Palmer-Bowlus flumes are usually identified by the diameter of the sewer into which they fit rather than by throat width. Manufacturers' literature should be consulted for information on these and other flume and weir products. Dimensions should be carefully checked.

6.6 Channel Conditions:

6.6.1 Velocity Distribution:

6.6.1.1 Ideally, the velocity distribution just upstream of weirs and flumes should approach that in a long, straight, relatively smooth channel. Standards usually recommend the length of straight approach channel needed to accomplish this result; however, users should confirm the approach conditions on a case-by-case basis. Where the water is relatively clear, upstream baffles can be used to improve the velocity distribution, provided they do not affect the head measurement.

6.6.1.2 In cases in which the ideal approach flow cannot be attained, it is noted that flumes generally are affected less than weirs by moderately skewed velocity distributions. Also, the velocity distribution of the approach flow is less important when this flow is of very low velocity.

6.6.2 *Supercritical Flow*—Weirs and flumes can be used in supercritical-flow channels, provided that a hydraulic jump is formed upstream so that the approach flow is subcritical. The individual standards specify the upstream distance of the jump.

6.6.3 Channel Shape:

6.6.3.1 Rectangular approach channels are preferred for thin-plate weirs, with exceptions for fully contracted weirs as described in Test Method D 5242; they are required for full-width (or suppressed) rectangular weirs.

NOTE 1—Full-width rectangular thin-plate weirs require special provision for aeration of the nappe.

6.6.3.2 Rectangular approach channels are required for broad-crested weirs. However, this condition can be satisfied in

 **D 5640**

a non-rectangular channel by construction of vertical sidewalls extending a prescribed distance upstream of the head measurement location and with appropriate transitions as described in Test Method D 5614.

6.6.3.3 Circular channels (sewers) (see 6.5.2).

7. Secondary System

7.1 The requirements for head measurement and associated instrumentation are basically similar for all weirs and flumes and therefore are not considered among the selection criteria in this guide. (An exception is the Parshall flume, which requires

an additional head measurement if used in the submerged mode; other flumes and broad-crested weirs in some instances may require downstream head monitoring to ensure unsubmerged operation.) Refer to the individual standards for secondary-system requirements.

7.2 The secondary measurement is a significant contributor to the total error of a flow measurement (see 6.1.1 and 6.1.3).

8. Keywords

8.1 flumes; open-channel flow; water discharge; weirs

REFERENCES

- (1) Kilpatrick, F. A., and Schneider, V. R., "Use of Flumes in Measuring Discharge," Book 3, Chapter A14 of *Techniques of Water-Resources Investigations of the U.S. Geological Survey*, 1983, pp. 1–46.
- (2) "U.S. Agricultural Research Service, Field Manual for Research in Agricultural Hydrology," *USDA Handbook 724*, 1962, pp. 43–80.
- (3) Carter, R. W., and Davidian, J., "General Procedure for Gaging Streams," *Techniques of Water Resources Investigations of the U.S. Geological Survey*, Book 3, Chapter , 1969, p. 7.
- (4) Buchanan, T. J., and Somers, W. P., "Discharge Measurements at Gaging Stations," *Techniques of Water Resources Investigations of the U.S. Geological Survey* , Book 3, Chapter A8, 1969, pp. 57–63.
- (5) Grant, D. M., *ISCO Open-Channel Flow Measurement Handbook*, 3rd Ed., 1989, pp. 40–46.

The American Society for Testing and Materials takes no position respecting the validity of any patent rights asserted in connection with any item mentioned in this standard. Users of this standard are expressly advised that determination of the validity of any such patent rights, and the risk of infringement of such rights, are entirely their own responsibility.

This standard is subject to revision at any time by the responsible technical committee and must be reviewed every five years and if not revised, either reapproved or withdrawn. Your comments are invited either for revision of this standard or for additional standards and should be addressed to ASTM Headquarters. Your comments will receive careful consideration at a meeting of the responsible technical committee, which you may attend. If you feel that your comments have not received a fair hearing you should make your views known to the ASTM Committee on Standards, at the address shown below.

This standard is copyrighted by ASTM, 100 Barr Harbor Drive, PO Box C700, West Conshohocken, PA 19428-2959, United States. Individual reprints (single or multiple copies) of this standard may be obtained by contacting ASTM at the above address or at 610-832-9585 (phone), 610-832-9555 (fax), or service@astm.org (e-mail); or through the ASTM website (www.astm.org).