



Designation: D 5755 – 023

Standard Test Method for Microvacuum Sampling and Indirect Analysis of Dust by Transmission Electron Microscopy for Asbestos Structure Number Surface Loading¹

This standard is issued under the fixed designation D 5755; the number immediately following the designation indicates the year of original adoption or, in the case of revision, the year of last revision. A number in parentheses indicates the year of last reapproval. A superscript epsilon (ϵ) indicates an editorial change since the last revision or reapproval.

1. Scope

1.1 This test method covers a procedure to (a) identify asbestos in dust and (b) provide an estimate of the surface loading of asbestos in the sampled dust reported as the number of asbestos structures per unit area of sampled surface.

1.1.1 If an estimate of the asbestos mass is to be determined, the user is referred to Test Method D 5756.

1.2 This test method describes the equipment and procedures necessary for sampling, by a microvacuum technique, non-airborne dust for levels of asbestos structures. The non-airborne sample is collected inside a standard filter membrane cassette from the sampling of a surface area for dust which may contain asbestos.

1.2.1 This procedure uses a microvacuuming sampling technique. The collection efficiency of this technique is unknown and will vary among substrates. Properties influencing collection efficiency include surface texture, adhesiveness, electrostatic properties and other factors.

1.3 Asbestos identified by transmission electron microscopy (TEM) is based on morphology, selected area electron diffraction (SAED), and energy dispersive X-ray analysis (EDXA). Some information about structure size is also determined.

1.4 This test method is generally applicable for an estimate of the surface loading of asbestos structures starting from approximately 1000 asbestos structures per square centimetre.

1.4.1 The procedure outlined in this test method employs an indirect sample preparation technique. It is intended to disperse aggregated asbestos into fundamental fibrils, fiber bundles, clusters, or matrices that can be more accurately quantified by transmission electron microscopy. However, as with all indirect sample preparation techniques, the asbestos observed for quantification may not represent the physical form of the asbestos as sampled. More specifically, the procedure described neither creates nor destroys asbestos, but it may alter the physical form of the mineral fibers.

1.5 The values stated in SI units are to be regarded as the standard. The values given in parentheses are for information only.

1.6 *This standard does not purport to address all of the safety concerns, if any, associated with its use. It is the responsibility of the user of this standard to establish appropriate safety and health practices and determine the applicability of regulatory limitations prior to use.*

2. Referenced Documents

2.1 ASTM Standards:

D 1193 Specification for Reagent Water²

¹ This test method is under the jurisdiction of ASTM Committee D22 on Sampling and Analysis of Atmospheres and is the direct responsibility of Subcommittee D22.07 on Sampling and Analysis of Asbestos.

Current edition approved ~~November~~ April 10, 2002³. Published ~~January 2002~~ June 2003. Originally approved in 1995. Last previous edition approved in ~~1995~~ 2002 as D 5755 - 9502.

D 3195 Practice for Rotameter Calibration³

D 3670 Guide for Determination of Precision and Bias of Methods of Committee D-22³

D 5756 Test Method for Microvacuum Sampling and Indirect Analysis of Dust by Transmission Electron Microscopy for Asbestos Mass Surface Loading³

D 6620 Practice for Determining a Detection Limit for Asbestos Measurements Based on Counts³

3. Terminology

3.1 Definitions:

3.1.1 *asbestiform*—a special type of fibrous habit in which the fibers are separable into thinner fibers and ultimately into fibrils. This habit accounts for greater flexibility and higher tensile strength than other habits of the same mineral. For more information on asbestiform mineralogy, see Refs (1),⁴ (2) and (3).

3.1.2 *asbestos*—a collective term that describes a group of naturally occurring, inorganic, highly fibrous, silicate dominated minerals, which are easily separated into long, thin, flexible fibers when crushed or processed.

3.1.2.1 *Discussion*—Included in the definition are the asbestiform varieties of: serpentine (chrysotile); riebeckite (crocidolite); grunerite (grunerite asbestos); anthophyllite (anthophyllite asbestos); tremolite (tremolite asbestos); and actinolite (actinolite asbestos). The amphibole mineral compositions are defined according to nomenclature of the International Mineralogical Association (3).

| Asbestos | Chemical Abstract Service No. ⁵ |
|------------------------|--|
| Chrysotile | 12001-29-5 |
| Crocidolite | 12001-28-4 |
| Grunerite Asbestos | 12172-73-5 |
| Anthophyllite Asbestos | 77536-67-5 |
| Tremolite Asbestos | 77536-68-6 |
| Actinolite Asbestos | 77536-66-4 |

3.1.3 *fibril*—a single fiber that cannot be separated into smaller components without losing its fibrous properties or appearance.

3.2 Definitions of Terms Specific to This Standard:

3.2.1 *aspect ratio*—the ratio of the length of a fibrous particle to its average width.

3.2.2 *bundle*—a structure composed of three or more fibers in a parallel arrangement with the fibers closer than one fiber diameter to each other.

3.2.3 *cluster*—a structure with fibers in a random arrangement such that all fibers are intermixed and no single fiber is isolated from the group; groupings of fibers must have more than two points touching.

3.2.4 *debris*—materials that are of an amount and size (particles greater than 1 mm in diameter) that can be visually identified as to their source.

3.2.5 *dust*—any material composed of particles in a size range of <1 mm.

3.2.6 *fiber*—a structure having a minimum length of 0.5 μm, an aspect ratio of 5:1 or greater, and substantially parallel sides (4).

3.2.7 *fibrous*—of a mineral composed of parallel, radiating, or interlaced aggregates of fibers, from which the fibers are sometimes separable. That is, the crystalline aggregate may be referred to as fibrous even if it is not composed of separable fibers, but has that distinct appearance. The term fibrous is used in a general mineralogical way to describe aggregates of grains that crystallize in a needle-like habit and appear to be composed of fibers. Fibrous has a much more general meaning than asbestos. While it is correct that all asbestos minerals are fibrous, not all minerals having fibrous habits are asbestos.

3.2.8 *indirect preparation*—a method in which a sample passes through one or more intermediate steps prior to final filtration.

3.2.9 *matrix*—a structure in which one or more fibers, or fiber bundles that are touching, are attached to, or partially concealed by a single particle or connected group of non-fibrous particles. The exposed fiber must meet the fiber definition (see 3.2.6).

3.2.10 *structures*—a term that is used to categorize all the types of asbestos particles which are recorded during the analysis (such as fibers, bundles, clusters, and matrices). Final results of the test are always expressed in asbestos structures per square centimetre.

4. Summary of Test Method

4.1 The sample is collected by vacuuming a known surface area with a standard 25 or 37 mm air sampling cassette using a plastic tube that is attached to the inlet orifice which acts as a nozzle. The sample is transferred from inside the cassette to an aqueous suspension of known volume. Aliquots of the suspension are then filtered through a membrane. A section of the membrane is prepared and transferred to a TEM grid using the direct transfer method. The asbestiform structures are identified, sized, and counted by TEM, using SAED and EDXA at a magnification of 15 000 to 20 000X.

² Annual Book of ASTM Standards, Vol 11.01.

³ Annual Book of ASTM Standards, Vol 11.03.

⁴ The boldface numbers in parentheses refer to the list of references at the end of this test method.

⁵ The non-asbestiform variations of the minerals indicated in 5.1.3 have different Chemical Abstract Service (CAS) numbers.

5. Significance and Use

5.1 This microvacuum sampling and indirect analysis method is used for the general testing of non-airborne dust samples for asbestos. It is used to assist in the evaluation of dust that may be found on surfaces in buildings such as ceiling tiles, shelving, electrical components, duct work, carpet, etc. This test method provides an index of the surface loading of asbestos structures in the dust per unit area analyzed as derived from a quantitative TEM analysis.

5.1.1 This test method does not describe procedures or techniques required to evaluate the safety or habitability of buildings with asbestos-containing materials, or compliance with federal, state, or local regulations or statutes. It is the user's responsibility to make these determinations.

5.1.2 At present, no relationship has been established between asbestos-containing dust as measured by this test method and potential human exposure to airborne asbestos. Accordingly, the users should consider other available information in their interpretation of the data obtained from this test method.

5.2 This definition of dust accepts all particles small enough to pass through a 1 mm (No. 18) screen. Thus, a single, large asbestos containing particle(s) (from the large end of the particle size distribution) dispersed during sample preparation may result in anomalously large asbestos surface loading results in the TEM analyses of that sample. It is, therefore, recommended that multiple independent samples are secured from the same area, and that a minimum of three samples be analyzed by the entire procedure.

6. Interferences

6.1 The following minerals have properties (that is, chemical or crystalline structure) which are very similar to asbestos minerals and may interfere with the analysis by causing a false positive to be recorded during the test. Therefore, literature references for these materials must be maintained in the laboratory for comparison to asbestos minerals so that they are not misidentified as asbestos minerals.

6.1.1 *Antigorite*.

6.1.2 *Palygorskite (Attapulgitite)*.

6.1.3 *Halloysite*.

6.1.4 *Pyroxenes*.

6.1.5 *Sepiolite*.

6.1.6 *Vermiculite scrolls*.

6.1.7 *Fibrous talc*.

6.1.8 Hornblende and other amphiboles other than those listed in 3.1.2.

6.2 Collecting any dust particles greater than 1 mm in size in this test method may cause an interference and, therefore, must be avoided.

7. Materials and Equipment

7.1 *Purity of Reagents*—Reagent grade chemicals shall be used in all tests. Unless otherwise indicated, it is intended that all reagents conform to the specifications of the Committee on Analytical Reagents of the American Chemical Society, where such specifications are available. Other grades may be used, provided it is first ascertained that the reagent is of sufficiently high purity to permit its use without lessening the accuracy of the determination.⁶

7.2 *Transmission Electron Microscope (TEM)*, an 80 to 120 kV TEM, capable of performing electron diffraction, with a fluorescent screen inscribed with calibrated gradations, is required. The TEM must be equipped with energy dispersive X-ray spectroscopy (EDXA) and it must have a scanning transmission electron microscopy (STEM) attachment or be capable of producing a spot size of less than 250 nm in diameter in crossover.

7.3 *Energy Dispersive X-ray System (EDXA)*.

7.4 *High Vacuum Carbon Evaporator*, with rotating stage.

7.5 *High Efficiency Particulate Air (HEPA)*, filtered negative flow hood.

7.6 *Exhaust or Fume Hood*.

7.7 *Particle-free Water* (ASTM Type II, see Specification D 1193).

7.8 *Glass Beakers* (50 mL).

7.9 *Glass Sample Containers*, with wide mouth screw cap (200 mL) or equivalent sealable container (height of the glass sample container should be approximately 13 cm high by 6 cm wide).

7.10 *Waterproof Markers*.

7.11 *Forceps* (tweezers).

7.12 *Ultrasonic Bath*, table top model (100 W).

7.13 *Graduated Pipettes* (1, 5, 10 mL sizes), glass or plastic.

⁶ *Reagent Chemicals, American Chemical Society Specifications*, American Chemical Society, Washington, DC. For suggestions on the testing of reagents not listed by the American Chemical Society, see *Analar Standards for Laboratory Chemicals*, BDH Ltd., Poole, Dorset, U.K., and the *United States Pharmacopeia and National Formulary*, U.S. Pharmaceutical Convention, Inc. (USPC), Rockville, MD.

7.14 *Filter Funnel*, either 25 mm or 47 mm, glass or disposable. Filter funnel assemblies, either glass or disposable plastic, and using either a 25 mm or 47 mm diameter filter.

7.15 *Side Arm Filter Flask*, 1000 mL.

7.16 *Mixed Cellulose Ester (MCE) Membrane Filters*, 25 or 47 mm diameter, $\leq 0.22 \mu\text{m}$ and $5 \mu\text{m}$ pore size.

7.17 *Polycarbonate (PC) Filters*, 25 or 47 mm diameter, $\leq 0.2 \mu\text{m}$ pore size.

7.18 *Storage Containers*, for the 25 or 47 mm filters (for archiving).

7.19 *Glass Slides*, approximately 76 by 25 mm in size.

7.20 *Scalpel Blades*, No. 10, or equivalent.

7.21 *Cabinet-type Desiccator*, or low temperature drying oven.

7.22 *Chloroform*, reagent grade.

7.23 *Acetone*, reagent grade.

7.24 *Dimethylformamide (DMF)*.

7.25 *Glacial Acetic Acid*.

7.26 *1-methyl-2-pyrrolidone*.

7.27 *Plasma Asher*, low temperature.

7.28 *pH Paper*.

7.29 *Air Sampling Pump*, low volume personal-type, capable of achieving a flow rate of 1 to 5 L/min.

7.30 *Rotameter*.

7.31 *Air Sampling Cassettes*, 25 mm or 37 mm, containing $0.8 \mu\text{m}$ or smaller pore size MCE or PC filters.

7.32 *Cork Borer*, 7 mm.

7.33 *Non-Asbestos Mineral*, references as outlined in 6.1.

7.34 *Asbestos Standards*, as outlined in 3.1.2.

7.35 *Tygon⁷ Tubing*, or equivalent.

7.36 *Small Vacuum Pump*, that can maintain a pressure of 92 kPa.

7.37 *Petri Dishes*, large glass, approximately 90 mm in diameter.

7.38 *Jaffe Washer*, stainless steel or aluminum mesh screen, 30 to 40 mesh, and approximately 75 mm by 50 mm in size.

7.39 *Copper TEM Finder Grids*, 200 mesh.

7.40 *Carbon Evaporator Rods*.

7.41 *Lens Tissue*.

7.42 *Ashless Filter Paper Filters*, 90 mm diameter.

7.43 *Gummed Paper Reinforcement Rings*.

7.44 *Wash Bottles*, plastic.

7.45 *Reagent Alcohol*, HPLC Grade (Fisher A995 or equivalent).

7.46 *Opening Mesh Screen*, plastic, 1.0 by 1.0 mm, (Spectra-Mesh #146410 or equivalent).

7.47 *Diffraction Grating Replica*.

8. Sampling Procedure for Microvacuum Technique

8.1 For sampling asbestos-containing dust in either indoor or outdoor environments, commercially available cassettes must be used. Air monitoring cassettes containing 25 mm or 37 mm diameter mixed cellulose ester (MCE) or polycarbonate (PC) filter membranes with a pore size less than or equal to $0.8 \mu\text{m}$ are required (7.31). The number of samples collected depends upon the specific circumstances of the study.

8.2 Maintain a log of all pertinent sampling information and sampling locations.

8.3 Sampling pumps and flow indicators shall be calibrated using a certified standard apparatus or assembly (see Practice D 3195 and 7.29).

8.4 Record all calibration information (5).

8.5 Perform a leak check of the sampling system at each sampling site by activating the pump (7.29) with the closed sampling cassette in line. Any air flow shows that a leak is present that must be eliminated before initiating the sampling operation.

8.6 Attach the sampling cassette to the sampling pump at the outlet side of the cassette with plastic tubing (7.35). The plastic tubing must be long enough in that the sample areas can be reached without interference from the sampling pump. Attach a clean, approximately 25.4 mm long piece of plastic tubing (6.35 mm internal diameter) directly to the inlet orifice. Use this piece of tubing as the sampling nozzle. Cut the sampling end of the tubing at a 45° angle as illustrated in Fig. 1. The exact design of the nozzle is not critical as long as some vacuum break is provided to avoid simply pushing the dust around on the surface with the nozzle rather than vacuuming it into the cassette. The internal diameter of the nozzle and flow rate of the pump may vary as long as the air velocity is $100 (\pm 10) \text{ cm/s}$. This air velocity calculation is based on an internal sampling tube diameter of 6.35 mm at a flow rate of 2 L/min.

8.7 Measure and determine the sample area of interest. A sample area of 100 cm^2 is vacuumed until there is no visible dust or particulates matter remaining. Perform a minimum of two orthogonal passes on the surface within a minimum of 2 min of sampling

⁷ Tygon is a registered trademark of the DuPont Co.

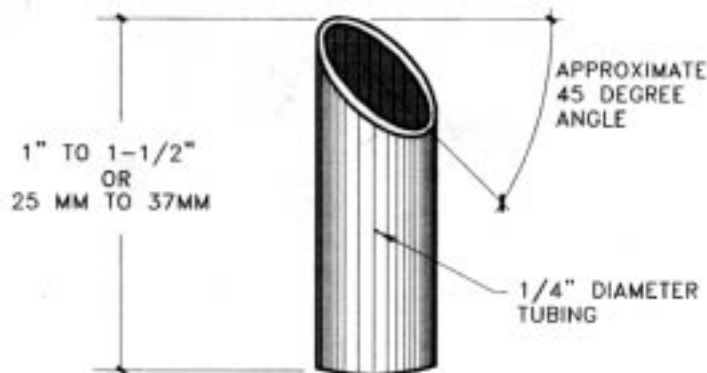

FIG. 1 Example of the Tubing Nozzle

time. Avoid scraping or abrading the surface being sampled. (Do not sample any debris or dust particles greater than 1 mm in diameter (see 4.2).) Smaller or larger areas can be sampled, if needed. For example, some surfaces of interest may have a smaller area than 100 cm². Less dusty surfaces may require vacuuming of larger areas. Unlike air samples, the overloading of the cassettes with dust will not be a problem. As defined in 3.2.5, only dust shall be collected for this analysis.

8.8 At the end of sample collection, invert the cassette so that the nozzle inlet faces up before shutting off the power to the pump. The nozzle is then sealed with a cassette end-plug and the cassette/nozzle taped or appropriately packaged to prevent separation of the nozzle and cassette assembly. A second option is the removal of the nozzle from the cassette, then plugging of the cassette and shipment of the nozzle (also plugged at both ends) sealed in a separate closeable plastic bag. A third option is placing the nozzle inside the cassette for shipment. The nozzle is always saved and rinsed because a significant percentage of the dust drawn from a lightly loaded surface may adhere to the inside walls of the tubing.

8.9 Check that all samples are clearly labeled, that all dust sampling information sheets are completed, and that all pertinent information has been enclosed, in accordance with laboratory quality control practices, before transfer of the samples to the laboratory. Include an unused cassette and nozzle as a field blank.

8.10 Wipe off the exterior surface of the cassettes with disposable wet towels (baby wipes) prior to packaging for shipment.

9. Sample Shipment

9.1 Ship dust samples to an analytical laboratory in a sealed container, but separate from any bulk or air samples. The cassettes must be tightly sealed and packed in a material free of fibers or dust to minimize the potential for contamination. Plastic “bubble pack” is probably the most appropriate material for this purpose.

10. Sample Preparation

10.1 Under a negative flow HEPA hood (7.5), carefully wet-wipe the exterior of the cassettes to remove any possible contamination before taking cassettes into a clean preparation area.

10.2 Perform sample preparation in a clean facility that has a separate work area from both the bulk and air sample preparation areas.

10.3 Initial specimen preparation shall take place in a clean HEPA filtered negative pressure hood to avoid any possible contamination of the laboratory or personnel, or both, by the potentially large number of asbestos structures in an asbestos-containing dust sample. Cleanliness of the preparation area hoods is measured by the cumulative process blank surface loadings (see Section 11).

10.4 All sample preparation steps 10.4.1-10.4.6 shall take place in the dust preparation area inside a HEPA hood.

10.4.1 Remove the upper plug from the sample cassette and carefully introduce approximately 10 mL solution of a 50/50 mixture of particle-free water and reagent alcohol into the cassette using a plastic wash bottle (7.44). If the plugged nozzle was left attached to the cassette, then remove the plug and introduce the water/alcohol solution into the cassette through the tubing, and then remove the tubing, if it is visibly clean.

10.4.2 Replace the upper plug or the sample cap and lightly shake the dust solution by hand for 3 s.

10.4.3 Remove the entire cap of the cassette and pour the suspension through a 1.0 by 1.0 mm opening screen (7.46) into a pre-cleaned 200 mL glass specimen bottle (7.9). All visible traces of the sample contained in the cassette shall be rinsed through the screen into the specimen bottle with a plastic wash bottle containing the 50/50 solution of particle-free water and alcohol. Repeat this procedure two additional times for a total of three washings. Next, rinse the nozzle two or three times through the screen into the specimen bottle with the 50/50 mixture of water and alcohol. Typically, the total amount of the 50/50 mixture used in the rinse is 50 to 75 mL. Discard the 1.0 by 1.0 mm screen and bring the volume of suspension in the specimen bottle up to the 100 mL mark on the side of the bottle with particle-free water only.

10.4.4 Adjust the pH of the suspension to 3 to 4 using a 10.0 % solution of acetic acid. Use pH paper for testing. Filter the

suspension within 24 h to avoid problems associated with bacterial and fungal growth.

10.4.5 Use either a disposable plastic filtration unit or a glass filtering unit (7.14) for filtration of aliquots of the suspension. The ability of an individual filtration unit to produce a uniform distribution may be tested by the filtration of a colored particulate solution such as diluted India ink (solution of carbon black).

10.4.5.1 If a disposable plastic filtration unit is used, then unwrap a new disposable plastic filter funnel unit (either 25 or 47 mm diameter) and remove the tape around the base of the funnel. Remove the funnel and discard the top filter supplied with the apparatus, retaining the coarse polypropylene support pad in place. Assemble the unit with the adapter and a properly sized neoprene stopper, and attach the funnel to the 1000 mL side-arm vacuum flask (7.15). Place a 5.0 μm pore size MCE (backing filter) on the support pad. Wet it with a few mL of particle-free water and place an MCE (7.16) or PC filter ($\leq 0.22 \mu\text{m}$ pore size) (7.17) on top of the backing filter. Apply a vacuum (7.36), ensuring that the filters are centered and pulled flat without air bubbles. Any irregularities on the filter surface requires the discard of that filter. After the filter has been seated properly, replace the funnel and reseal it with the tape. Return the flask to atmospheric pressure.

10.4.5.2 If a glass filtration unit is used, place a 5 μm pore size MCE (backing filter) on the glass frit surface. Wet the filter with particle-free water, and place an MCE or PC filter ($\leq 0.22 \mu\text{m}$ pore size) on top of the backing filter. Apply a vacuum, ensuring that the filters are centered and pulled flat without air bubbles. Replace the filters if any irregularities are seen on the filter surface. Before filtration of each set of sample aliquots, prepare a blank filter by filtration of 50 mL of particle-free water. If aliquots of the same sample are filtered in order of increasing surface loading, the glass filtration unit need not be washed between filtration. After completion of the filtration, do not allow the filtration funnel assembly to dry because contamination is then more difficult to remove. Wash any residual solution from the filtration assembly by holding it under a flow of water, then rub the surface with a clean paper towel soaked in a detergent solution. Repeat the cleaning operation, and then rinse two times in particle-free water.

10.4.6 With the flask at atmospheric pressure, add 20 mL of particle-free water into the funnel. Cover the filter funnel with its plastic cover if the disposable filtering unit is used.

10.4.7 Briefly hand shake (3 s) the capped bottle with the sample suspension, then place it in a tabletop ultrasonic bath (7.12) and sonicate for 3.0 min. Maintain the water level in the sonicator at the same height as the suspension in sample bottle. The ultrasonic bath shall be calibrated as described in 20.5. The ultrasonic bath must be operated at equilibrium temperature. After sonicating, return the sample bottle to the work surface of the HEPA hood. Preparation steps 10.4.8-10.4.14 shall be carried out in this hood.

10.4.8 Shake the suspension lightly by hand for 3 s, then let it rest for 2.0 min to allow large particles to settle to the bottom of the bottle or float to the surface.

10.4.9 Estimate the amount of liquid to be withdrawn to produce an adequate filter preparation. Experience has shown that a light staining of the filter surface will yield a suitable preparation for analysis. Filter at least 1.0 mL, but no more than half the total volume. If after examination in the TEM, the smallest volume measured (1.0 mL) (7.13) yields an overloaded sample, then perform additional serial dilutions of the suspension. If it is estimated that less than 1.0 mL of suspension has to be filtered because of the density of the suspension, perform a serial dilution.

10.4.9.1 If serial dilutions are required, repeat step 10.4.8 before the serial dilution portion is taken. Do not re-sonicate the original suspension or any serial dilutions. The recommended procedure for a serial dilution is to mix 10 mL of the sample suspension with 90 mL of particle-free water in a clean sample bottle to obtain a 1:10 serial dilution. Follow good laboratory practices when performing dilutions.

10.4.10 Insert a new disposable pipette halfway into the sample suspension and withdraw a portion. Avoid pipetting any of the large floating or settled particles. Uncover the filter funnel and dispense the mixture from the pipette into the water in the funnel.

10.4.11 Apply vacuum to the flask and draw the mixture through the filter.

10.4.12 Discard the pipette.

10.4.13 Disassemble the filtering unit and carefully remove the sample filter with fine tweezers (7.11). Place the completed sample filter particle side up, into a precleaned, labeled, disposable, plastic petri dish (7.48) or other similar container.

10.4.14 In order to ensure that an optimally-loaded filter is obtained, it is recommended that filters be prepared from several different aliquots of the dust suspension. For this series of filters, it is recommended that the volume of each aliquot of the original suspension be a factor of five higher than the previous one. If the filters are prepared in order of increasing aliquot volume, all of the filters for one sample can be prepared using one plastic disposable filtration unit, or without cleaning of glass filtration equipment between individual filtration. Before withdrawal of each aliquot from the sample, shake the suspension without additional sonification and allow to rest for 2 min.

10.4.15 There are many practical methods for drying MCE filters. The following are two examples that can be used: (1) dry MCE filters for at least 12 h (over desiccant) in an airtight cabinet-type desiccator (7.21); (2) to shorten the drying time (if desired), remove a plug of the damp filter and attach it to a glass slide (7.19) as described in 12.1.2 and 12.1.3. Place the slide with a filter plug or filter plugs (up to eight plugs can be attached to one slide) on a bed of desiccant, in the desiccator for 1 h.

10.4.16 PC filters do not require lengthy drying before preparation, but shall be placed in a desiccator for at least 30 min before preparation.

10.5 Prepare TEM specimens from small sections of each dried filter using the appropriate direct transfer preparation method.

11. Blanks

11.1 Prepare sample blanks that include both a process blank (50 mL of particle-free water) for each set of samples analyzed and one unused filter from each new box of sample filters (MCE or PC) used in the laboratory. If glass filtering units are used, prepare and analyze a process blank each time the filtering unit is cleaned. Blanks will be considered contaminated, if after analysis, they are shown to contain more than 53 asbestos structures per square millimetre. This generally corresponds to three or four asbestos structures found in ten grid openings. The source of the contamination must be found before any further analysis can be performed. Reject samples that were processed along with the contaminated blanks and prepare new samples after the source of the contamination is found.

11.2 Prepare field blanks which are included with sample sets in the same manner as the samples, to test for contamination during the sampling, shipping, handling, and preparation steps of the method.

12. TEM Specimen Preparation of Mixed Cellulose Ester (MCE) Filters

NOTE 1—Use of either the acetone or the dimethylformamide-acetic acid method is acceptable.

12.1 Acetone Fusing Method:

12.1.1 Remove a section (a plug) from any quadrant of the sample and blank filters. Sections can be removed from the filters using a 7 mm cork borer (7.32). The cork borer must be wet wiped after each time a section is removed.

12.1.2 Place the filter section (particle side up) on a clean microscope slide. Affix the filter section to the slide with a gummed page reinforcement (7.43), or other suitable means. Label the slide with a glass scribing tool or permanent marker (7.10).

12.1.3 Prepare a fusing dish from a glass petri dish (7.37) and a metal screen bridge (7.38) with a pad of five to six ashless paper filters (7.42) and place in the bottom of the petri dish (4). Place the screen bridge on top of the pad and saturate the filter pads with acetone. Place the slide on top of the bridge in the petri dish and cover the dish. Wait approximately 5 min for the sample filter to fuse and clear.

12.2 Dimethylformamide-Acetic Acid Method:

12.2.1 Place a drop of clearing solution that consists of 35 % dimethylformamide (DMF), 15 % glacial acetic acid, and 50 % Type II water (v/v) on a clean microscope slide. Gauge the amount used so that the clearing solution just saturates the filter section.

12.2.2 Carefully lay the filter segment, sample surface upward, on top of the solution. Bring the filter and solution together at an angle of about 20° to help exclude air bubbles. Remove any excess clearing solution. Place the slide in an oven or on a hot plate, in a fume hood, at 65 to 70°C for 10 min.

12.3 Plasma etching of the collapsed filter is required.

12.3.1 The microscope slide to which the collapsed filter pieces are attached is placed in a plasma asher (7.27). Because plasma ashers vary greatly in their performance, both from unit to unit and between different positions in the asher chamber, it is difficult to specify the exact conditions that must be used. Insufficient etching will result in a failure to expose embedded fibers, and too much etching may result in the loss of particles from the filter surface. To determine the optimum time for ashing, place an unused 25 mm diameter MCE filter in the center of a glass microscope slide. Position the slide approximately in the center of the asher chamber. Close the chamber and evacuate to a pressure of approximately 40 Pa, while admitting oxygen to the chamber at a rate of 8 to 20 cm³/min. Adjust the tuning of the system so that the intensity of the plasma is maximized. Determine the time required for complete oxidation of the filter. Adjust the system parameters to achieve complete oxidation of the filter in a period of approximately 15 min. For etching of collapsed filters, use these operating parameters for a period of 8 min. For additional information on calibration, see the *USEPA Asbestos-Containing Materials in Schools* (4) or *NIST/NVLAP Program Handbook for Airborne Asbestos Analysis* (6) documents.

12.3.2 Place the glass slide containing the collapsed filters into the low-temperature plasma asher, and etch the filter.

12.4 Carbon coating of the collapsed and etched filters is required.

12.4.1 Carbon coating must be performed with a high-vacuum coating unit (7.4), capable of less than 10⁻⁴ torr (13 MPa) pressure. Units that are based on evaporation of carbon filaments in a vacuum generated only by an oil rotary pump have not been evaluated for this application and shall not be used. Carbon rods (7.40) used for evaporators shall be sharpened with a carbon rod sharpener to a neck of about 4 mm in length and 1 mm in diameter. The rods are installed in the evaporator in such a manner that the points are approximately 100 to 120 mm from the surface of the microscope slide held in the rotating device.

12.4.2 Place the glass slide holding the filters on the rotation device, and evacuate the evaporator chamber to a vacuum of at least 13 MPa. Perform the evaporation in very short bursts, separated by 3 to 4 s to allow the electrodes to cool. An alternate method of evaporation is by using a slow continuous applied current. An experienced analyst can judge the thickness of the carbon film to be applied. Conduct tests on unused filters first. If the carbon film is too thin, large particles will be lost from the TEM specimen, and there will be few complete and undamaged grid openings on the specimen.

12.4.2.1 If the coating is too thick, it will lead to a TEM image that is lacking in contrast, and the ability to obtain electron diffraction patterns will be compromised. The carbon film shall be as thin as possible and still remain intact on most of the grid openings of the TEM specimen.

12.5 Preparation of the Jaffe Washer— The precise design of the Jaffe washer is not considered important, so any one of the published designs may be used (7, 8). One such washer consists of a simple stainless steel bridge contained in a glass petri dish.

12.5.1 Place several pieces of lens tissue (7.41) on the stainless steel bridge. The pieces of lens tissue shall be large enough to

completely drape over the bridge and into the solvent. In a fume hood, fill the petri dish with acetone (or DMF) until the height of the solvent is brought up to contact the underside of the metal bridge as illustrated in Fig. 2.

12.6 Placing the Specimens into the Jaffe Washer:

12.6.1 Place the TEM grids (7.39) shiny side up on a piece of lens tissue or filter paper so that individual grids can be easily picked up with tweezers.

12.6.2 Prepare three grids from each sample.

12.6.2.1 Using a curved scalpel blade (7.20), excise at least two square (3 mm by 3 mm) pieces of the carbon-coated MCE filter from the glass slide.

12.6.2.2 Place the square filter piece carbon-side up on top of a TEM specimen grid.

12.6.2.3 Place the whole assembly (filter/grid) on the saturated lens tissue in the Jaffe washer.

12.6.2.4 Place the three TEM grid sample filter preparations on the same piece of lens tissue in the Jaffe washer.

12.6.2.5 Place the lid on the Jaffe washer and allow the system to stand for several hours.

12.7 Alternately, place the grids on a low level (petri dish filled to the 1/8 mark) DMF Jaffe washer for 60 min. Add enough solution of equal parts DMF/acetone to fill the washer to the screen level. Remove the grids after 30 min if they have cleared, that is, all filter material has been removed from the carbon film, as determined by inspection in the TEM.

12.8 Carefully remove the grids from the Jaffe washer, allowing the grids to dry before placing them in a clean marked grid box.

13. TEM Specimen Preparation of Polycarbonate (PC) Filter

13.1 Cover the surface of a clean microscope slide with two strips of double-sided adhesive tape.

13.2 Cut a strip of filter paper slightly narrower than the width of the slide. Position the filter paper strip on the center of the length of the slide.

13.3 Using a clean, curved scalpel blade, cut a strip of the PC filter approximately 25 by 6 mm. Use a rocking motion of the scalpel blade to avoid tearing the filter. Place the PC strip particle side up on the slide perpendicular to the long axis of the slide. The ends of the PC strip must contact the double sided adhesive tape. Each slide can hold several PC strips. With a glass marker, label each PC strip with the individual sample number.

13.4 Carbon coat the PC filter strips as discussed in 12.4.2. PC filters do not require etching.

NOTE 2—**Caution:** Do not overheat the filter sections while carbon coating.

13.5 Prepare a Jaffe washer as described in 12.5, but fill the washer with chloroform or 1-methyl-2-pyrrolidone to the level of the screen.

13.6 Using a clean curved scalpel blade, excise three, 3-mm square filter pieces from each PC strip. Place the filter squares carbon side up on the shiny side of a TEM grid. Pick up the grid and filter section together and place them on the lens tissue in the Jaffe washer.

13.7 Place the lid on the Jaffe washer and rest the grids in place for at least 4 h. Best results are obtained with longer wicking times, up to 12 h.

13.8 Carefully remove the grids from the Jaffe washer, allowing the grids to dry before placing them in a clean, marked grid box.

14. Grid Opening Measurements

14.1 TEM grids must have a known grid opening area. Determine this area as follows:

14.2 Measure at least 20 grid openings in each of 20 random 75 to 100 μm (200-mesh) copper grids for a total of 400 grid openings for every 1000 grids used, by placing the 20 grids on a glass slide and examining them under the optical microscope. Use a calibrated graticule to measure the average length and width of the 20 openings from each of the individual grids. From the accumulated data, calculate the average grid opening area of the 400 openings.

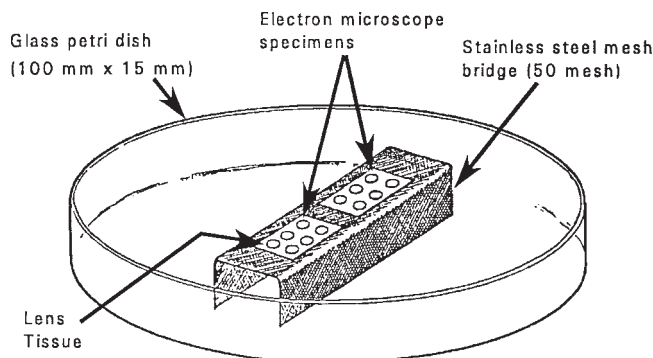

FIG. 2 Example of Design of Solvent Washer (Jaffe Washer)

14.3 Grid area measurements can also be made at the TEM at a calibrated screen magnification of between 15 000 and 20 000X. Typically measure one grid opening for each grid examined. Measure grid openings in both the x and y directions and calculate the area.

14.4 Pre-calibrated TEM grids are also acceptable for this test method.

15. TEM Method

15.1 Microscope settings: 80 to 120 kV, 15 000 to 20 000X screen magnification for analysis (7.2).

15.2 Analyze two grids for each sample. Analyze one-half of the sample area on one sample grid preparation and the remaining half on a second sample grid preparation.

15.3 *Determination of Specimen Suitability* :

15.3.1 Carefully load the TEM grid, carbon side facing up (in the TEM column) with the grid bars oriented parallel/perpendicular to the length of the specimen holder. Use a hand lens or loupe, if necessary. This procedure will line up the grid with the x and y translation directions of the microscope. Insert the specimen holder into the microscope.

15.3.2 Scan the entire grid at low magnification (250X to 1000X) to determine its suitability for high magnification analysis as specified in 15.3.3.

15.3.3 Grids are acceptable for analysis if the following conditions are met:

15.3.3.1 The fraction of grid openings covered by the replica section is at least 50 %.

15.3.3.2 Relative to that section of the grid covered by the carbon replica, the fraction of intact grid openings is greater than 50 %.

15.3.3.3 The fractional area of undissolved filter is less than 10 %.

15.3.3.4 The fraction of grid openings with overlapping or folded replica film is less than 50 %.

15.3.3.5 At least 20 grid openings, that have no overlapping or folded replica, are less than 5 % covered with holes and have less than 5 % opaque area due to incomplete filter dissolution.

15.4 *Determination of Grid Opening Suitability*:

15.4.1 If the grid meets acceptance criteria, choose a grid opening for analysis from various areas of the grid so that the entire grid is represented. Determine the suitability of each individual grid opening prior to the analysis.

15.4.2 The individual grid opening must have less than 5 % holes over its area.

15.4.3 Grid openings must be less than 25 % covered with particulate matter.

15.4.4 Grid openings must be uniformly loaded.

15.5 Observe and record the orientation of the grid at 80 to 150X, on a grid map record sheet along with the location of the grid openings that are examined for the analysis. If indexed grids are used, a grid map is not required, but the identifying coordinates of the grid square must be recorded.

16. Recording Data Rules

16.1 Record on the count sheet any continuous grouping of particles in which an asbestos fiber is detected. Classify asbestos structures as fibers, bundles, clusters, or matrices as defined in 5.2.

16.2 Use the criteria for fiber, bundle, cluster, and matrix identification, as described in the *USEPA Asbestos-Containing Materials in Schools* document (4). Record, for each AHERA structure identified, the length and width measurements.

16.3 Record NSD (No Structures Detected) when no structures are detected in the grid opening.

16.4 Identify structures classified as chrysotile identified by either electron diffraction or X-ray analysis (7.3) and recorded on a count sheet. Verify at least one out of every ten chrysotile structures by X-ray analysis.

16.5 Structures classified as amphiboles by X-ray analysis and electron diffraction are recorded on the count sheet. For more information on identification, see Yamate, et al, (7) or Chatfield and Dillon (8).

16.6 Record a typical electron diffraction pattern for each type of asbestos observed for each group of samples (or a minimum of every five samples) analyzed. Record the micrograph number on the count sheet. Record at least one X-ray spectrum for each type of asbestos observed per sample. Attach the print-outs to the back of the count sheet. If the X-ray spectrum is stored, record the file and disk number on the count sheet.

16.7 *Counting Rules*:

16.7.1 At a screen magnification of between 15 000 and 20 000X evaluate the grids for the most concentrated sample loading; reject the sample if it is estimated to contain more than 50 asbestos structures per grid opening. Proceed to the next lower concentrated sample until a set of grids are obtained that have less than 30 asbestos structures per grid opening.

16.8 *Analytical Sensitivity (AS)*—As determined by the following equation:

$$\frac{(EFA \times 100 \text{ mL} \times 1)}{(GO \times GOA \times V \times SPL)} = \text{asbestos structures/cm}^2 \quad (1)$$

$$(EFA \times 100 \text{ mL} \times 1) / (GO \times GOA \times V \times SPL) = AS \quad (1)$$

where:

EFA = effective filter area of the final sampling filter, mm²

GO = number of grid openings counted

GOA = average grid opening area, mm²

SPL = surface area sampled, cm²

V = volume of sample filtered in step 10.4.9, representing the actual volume taken from the original 100 mL suspension, mL

AS = analytical sensitivity, expressed as asbestos structures/cm²

An analytical sensitivity

16.8.1 An *AS* of approximately 1000 asbestos structures per square centimetre (calculated for the detection of a single asbestos structure) has been designed for this analysis. This sensitivity can be achieved by increasing the amount of liquid filtered, increasing the number of grid openings analyzed, increasing the area of the collection, or decreasing the size of the final filter. For example, using a collection area = 500 cm², filter area = 1000 mm², number of grid openings = 10, and a grid area of 0.01 mm², *V* = 50 mL, the analytical sensitivity *AS* is 40 str/cm². Occasionally, due to high particle loadings or high asbestos surface loading, this analytical sensitivity *AS* cannot be practically achieved and stopping rules apply.

16.8.2 The numerical value of *AS* required for any specific application of this method may be achieved by selecting an appropriate combination of the sampling and analysis parameters in the above equation. For example, if *SPL* = 100 cm², *EFA* = 1000 mm², *GO* = 10, *GOA* = 0.01 mm², *V* = 10 mL, and *D* = 1, then *AS* = 1000 str/cm². Increasing *GO* to 50 and *V* to 50 mL changes the *AS* to 40 Str/cm².

16.8.3 When sample filters are heavily loaded with particulate matter, it may useful to employ serial dilutions during preparation to reduce the loading on grid specimens to acceptable levels and thus facilitate analysis. Under such circumstances, the *AS* may be calculated by substituting an appropriate value for the dilution factor, *D*, into the above equation. In general:

$$D = VA/(V + VPFW) \quad (2)$$

VA = the volume of the aliquot from the new, diluted suspension that is filtered to prepare the analytical filter; *V* = the volume of the aliquot from the initial (100 mL) suspension that is diluted; and *VPFW* = the volume of particle free water added to *V* during serial dilution to produce the new, diluted suspension.

Thus, if *GO* = 10, *V* = 10 mL, *VPFW* = 90 mL, and *VA* = 1.0 mL, *D* = 0.01 and the *AS* = 100 000 str/cm².

16.9 *Limit of Detection*—The limit of detection for this test method is calculated using the Practice D 6620. All data shall be provided in the laboratory report.

16.10 *Stopping Rules*:

16.10.1 The analysis is stopped upon the completion of the grid square that achieves an analytical sensitivity *AS* of less than 1000 asbestos structures per square centimetre.

16.10.2 If an analytical sensitivity *AS* of 1000 asbestos structures per square centimetre cannot be achieved after analyzing ten grid openings then stop on grid opening No. 10 or the grid opening which contains the 100th asbestos structure, whichever comes first. A minimum of four grid squares shall be analyzed for each sample.

16.10.2.1 If the analysis is stopped because of the 100th structure rule, the entire grid square containing the 100th structure must be counted.

16.11 After analysis, remove the grids from the TEM, and replace them in the appropriate grid storage holder.

17. Sample Storage

17.1 The washed-out sample cassettes can be discarded after use.

17.2 Sample grids and unused filter sections (7.18) must be stored for a minimum of one year.

18. Reporting

18.1 Report the following information for each dust sample analyzed:

18.1.1 Surface loading in structures/cm².

18.1.2 The analytical sensitivity, *AS*.

18.1.3 Types of asbestos present.

18.1.4 Number of asbestos structures counted.

18.1.5 Effective filtration area.

18.1.6 Average size of the TEM grid openings that were counted.

18.1.7 Number of grid openings examined.

18.1.8 Sample dilution used.

18.1.9 Area of the surface sampled.

18.1.10 Listing of size data for each structure counted.

18.1.11 A copy of the TEM count sheet or a complete listing of the raw data. An example of a typical count sheet is shown in Appendix X1.

18.2 Determine the amount of asbestos in any accepted sample using the following formula:

$$\frac{EFA \times 100 \text{ mL} \times \#STR}{GO \times GOA \times V \times SPL} = \text{asbestos structures/cm}^2 \quad (3)$$

where:

- # *STR* = number of asbestos structures counted,
- EFA* = effective filter area of the final sampling filter, mm²,
- GO* = number of grid openings counted,
- GOA* = average grid opening area, mm²,
- SPL* = surface area sampled, cm², and
- V* = volume of sample filtered in step 10.4.9, representing the actual volume taken from the original 100 mL suspension, mL.

19. Quality Control/Quality Assurance

19.1 In general, the laboratory's quality control checks are used to verify that a system is performing according to specifications regarding accuracy and consistency. In an analytical laboratory, spiked or known quantitative samples are normally used. However, due to the difficulties in preparing known quantitative asbestos samples, routine quality control testing focuses on re-analysis of samples (duplicate recounts).

19.1.1 Re-analyze samples at a rate of 1/10 of the sample sets (one out of every ten samples analyzed not including laboratory blanks). The re-analysis shall consist of a second sample preparation obtained from the final filter.

19.2 In addition, quality assurance programs must follow the criteria shown in the *USEPA Asbestos-Containing Materials in Schools* document (4) and in the *NIST/NVLAP Program Handbook for Airborne Asbestos Analysis* document (6). These documents describe sample custody, sample preparation, blank checks for contamination, calibration, sample analysis, analyst qualifications, and technical facilities.

20. Calibrations

20.1 Perform calibrations of the instrumentation on a regular basis, and retain these records in the laboratory, in accordance with the laboratory's quality assurance program.

20.2 Record calibrations in a log book along with dates of calibration and the attached backup documentation.

20.3 A calibration list for the instrument is as follows:

20.3.1 *TEM*:

20.3.1.1 Check the alignment and the systems operation. Refer to the TEM manufacturer's operational manual for detailed instructions.

20.3.1.2 Calibrate the camera length of the TEM in electron diffraction (ED) operating mode before ED patterns of unknown samples are observed. Camera length can be measured by using a carbon coated grid on which a thin film of gold has been sputtered or evaporated. A thin film of gold is evaporated on the specimen TEM grid to obtain zone-axis ED patterns superimposed with a ring pattern from the polycrystalline gold film. In practice, it is desirable to optimize the thickness of the gold film so that only one or two sharp rings are obtained on the superimposed ED pattern. Thick gold films will tend to mask weak diffraction spots from the fibrous particles. Since the unknown d-spacings of most interest in asbestos analysis are those which lie closest to the transmitted beam, multiple gold rings from thick films are unnecessary. Alternatively, a gold standard specimen can be used to obtain an average camera constant calculated for that particular instrument and can then be used for ED patterns of unknowns taken during the corresponding period.

20.3.1.3 Perform magnification calibration at the fluorescent screen. This calibration must be performed at the magnification used for structure counting. Calibration is performed with a grating replica (7.47) (for example, one containing at least 2160 lines/mm).

(a) Define a field of view on the fluorescent screen. The field of view must be measurable or previously inscribed with a scale or concentric circles (all scales should be metric).

(b) Frequency of calibration will depend on the service history of the particular microscope.

(c) Check the calibration after any maintenance of the microscope that involves adjustment of the power supply to the lens or the high voltage system or the mechanical disassembly of the electron optical column (apart from filament exchange).

(d) The analyst must ensure that the grating replica is placed at the same distance from the objective lens as the specimen.

(e) For instruments that incorporate a eucentric tilting specimen stage, all specimens and the grating replica must be placed at the eucentric position.

20.3.1.4 The smallest spot size of the TEM must be checked.

(a) At the crossover point, photograph the spot size at a screen magnification of 15 000 to 20 000X. An exposure time of 1 s is usually adequate.

(b) The measured spot size must be less than or equal to 250 nm.

20.4 *EDXA*:

20.4.1 The resolution and calibration of the EDXA must be verified.

20.4.1.1 Collect a standard EDXA Cu peak from the Cu grid.

20.4.1.2 Compare the X-ray energy versus channel number for the Cu peak and be certain that readings are within ± 10 eV.

20.4.2 Collect a standard EDXA of crocidolite asbestos (NIST SRM 1866).

20.4.2.1 The elemental analysis of the crocidolite must resolve the Na peak.

20.4.3 Collect a standard EDXA of chrysotile asbestos.

20.4.3.1 The elemental analysis of chrysotile must resolve both Si and Mg on a single chrysotile fiber.

20.5 Ultrasonic bath calibration shall be performed as follows:

20.5.1 Fill the bath water to a level equal to the height of suspension in the glass sample container that will be used for the dust analysis. Operate the bath until the water reaches the equilibrium temperature.

20.5.2 Place 100 mL of water (at approximately 20°C) in another 200-mL glass sample container, and record its temperature.

20.5.3 Place the sample container in the water in the ultrasonic bath (with the power turned off). After 60 s, remove the glass container and record its temperature.

20.5.4 Place 100 mL of water (at approximately 20°C) in another 200-mL glass sample container, and record its temperature.

20.5.5 Place the second sample container into the water in the ultrasonic bath (with the power turned on). After 60 s, remove the glass container and record its temperature.

20.5.6 Calculate the rate of energy deposition into the sample container using the following formula:

$$R = 4.185 \times \sigma \times \rho \times \frac{(\theta_2 - \theta_1)}{t} \quad (4)$$

where:

4.185 = Joules/cal,

R = energy deposition, watts/mL,

θ_1 = temperature rise with the ultrasonic bath not operating, °C,

θ_2 = temperature rise with the ultrasonic bath operating, °C,

t = time in seconds, 60 s (20.5.3 and 20.5.5),

σ = specific heat of the liquid in the glass sample container, 1.0 cal/g, and

ρ = density of the liquid in the glass sample container, 1.0 g/cm³.

20.5.7 Adjust the operating conditions of the bath so that the rate of energy deposition is in the range of 0.08 to 0.12 MW/m³, as defined by this procedure.

21. Precision and Bias

21.1 *Precision*—The precision of the procedure in this test method is being determined using round robin data from participating laboratories.

21.2 *Bias*—Since there is no accepted reference material suitable for determining the bias of the procedure in this test method, bias has not been determined (see Specification D 3670).

NOTE 3—Round robin data is under development and will be presented as a research report.

22. Keywords

22.1 asbestos; microvacuuming; settled dust; TEM

APPENDIX

(Nonmandatory Information)

X1. DUST SAMPLE ANALYSIS

X1.1 See Figs. X1.1 and X1.2 for the dust analysis worksheet and the TEM count sheet.

- (1) Steel, E. and Wylie, A., “Mineralogical Characteristics of Asbestos,” in *Geology of Asbestos Deposits*, Riordon, P. H., Ed., SME-AIME, 1981, pp. 93–101.
- (2) Zussman, J., “The Mineralogy of Asbestos,” in *Asbestos: Properties, Applications and Hazards*, John Wiley and Sons, 1979, pp. 45–67.
- (3) Leake, B. E., “Nomenclature of Amphiboles,” *American Mineralogist*, Vol 63, 1978, pp. 1023–1052.
- (4) “USEPA Asbestos-Containing Materials in Schools: Final Rule and Notice,” *Federal Register*, 40 CFR Part 763, Appendix A to Sub-part E., Oct. 30, 1987.
- (5) OSHA, *OSHA Technical Manual, OSHA Instruction CPL 2-20B*, Directorate of Technical Support, U.S. Department of Labor, Washington, DC 20210, Feb. 5, 1990, pp. 1–8 to 1–11.
- (6) *NIST/NVLAP Program Handbook for Airborne Asbestos Analysis*, NISTIR, August 1989, pp. 89–4137.
- (7) Yamate, G., Agarwall, S. C., and Gibbons, R. D., “Methodology for the Measurement of Airborne Asbestos by Electron Microscopy,” EPA Draft Report, Contract No. 68-02-3266, 1984.
- (8) Chatfield, E. J., and Dillon, M. J., “Analytical Method for the Determination of Asbestos in Water,” EPA No. 600/4-83-043, 1983.

ASTM International takes no position respecting the validity of any patent rights asserted in connection with any item mentioned in this standard. Users of this standard are expressly advised that determination of the validity of any such patent rights, and the risk of infringement of such rights, are entirely their own responsibility.

This standard is subject to revision at any time by the responsible technical committee and must be reviewed every five years and if not revised, either reapproved or withdrawn. Your comments are invited either for revision of this standard or for additional standards and should be addressed to ASTM International Headquarters. Your comments will receive careful consideration at a meeting of the responsible technical committee, which you may attend. If you feel that your comments have not received a fair hearing you should make your views known to the ASTM Committee on Standards, at the address shown below.

This standard is copyrighted by ASTM International, 100 Barr Harbor Drive, PO Box C700, West Conshohocken, PA 19428-2959, United States. Individual reprints (single or multiple copies) of this standard may be obtained by contacting ASTM at the above address or at 610-832-9585 (phone), 610-832-9555 (fax), or service@astm.org (e-mail); or through the ASTM website (www.astm.org).