



Designation: F 1358 – 9500

Standard Test Method for Effects of Flame Impingement on Materials Used in Protective Clothing Not Designated Primarily for Flame Resistance¹

This standard is issued under the fixed designation F 1358; the number immediately following the designation indicates the year of original adoption or, in the case of revision, the year of last revision. A number in parentheses indicates the year of last reapproval. A superscript epsilon (ε) indicates an editorial change since the last revision or reapproval.

1. Scope

1.1 This test method establishes a small-scale laboratory screening procedure for comparing the ignition resistance and burning characteristics of materials used in protective clothing where flame resistance is not the primary form of protection provided by the clothing.

1.1.1 It is more appropriate to evaluate materials used in applications where flame resistance is the primary form of protection provided by the clothing by other flammability test methods. This test method shall not be used to evaluate materials where flame resistance is the primary form of protection offered by the protective clothing.

1.1.2 This test method provides a means for comparing ease of ignition and burning behavior of materials which include plastic or elastomeric films, coated fabrics, flexible laminates, multilayer-material systems, or other protective clothing materials that are not designated for offering flame resistance as their primary form of protection.

1.2 ~~This test method should be used to measure standard measures and describes the response of materials, products, or assemblies to heat and flame under controlled conditions and should conditions, but does not be used to describe or appraise the by itself incorporate all factors required for fire hazard or fire risk assessment of the materials, products, or assemblies under actual fire conditions. However, the results of this test may be used as elements of a fire hazard assessment or a fire risk assessment which takes into account all of the factors which are pertinent to an assessment of the fire hazard or fire risk of a particular end use conditions.~~

1.3 ~~The values stated in SI units or other units shall be regarded separately as standard, separately. The values stated in each system may not be exact equivalents; therefore, each system must be used independently of the other, independently, without combining values in any way. values.~~

1.4 *This standard does not purport to address all of the safety concerns, if any, associated with its use. It is the responsibility of the user of this standard to establish appropriate safety and health practices and determine the applicability of regulatory limitations prior to use.*

2. Referenced Documents

2.1 *ASTM Standards:*

¹ This test method is under the jurisdiction of ASTM Committee F-23 on Protective Clothing and is the direct responsibility of Subcommittee F23.80 on Flame and Thermal.

Current edition approved Oct. 10, ~~1995~~, 2000. Published December 2000. Originally published as F 1358 - 95. Last previous edition F 1358 - 95.

~~D 1230 Test Method for Flammability of Apparel Fabrics~~ 123 Terminology Relating to Textiles²

~~D 124391 Terminology Relating to The Burning Behavior of Textiles~~

~~2.2 Federal~~³

~~D 4723 Index of and Descriptions of Textile Heat and Flammability Test Methods:
Fe and Performance Specifications~~³

~~D 6413 Test Method Standard No. 191A, Method 5903-1 for Flame Resistance of Clothing, Vertical (December 28, 1989)~~³

² *Annual Book of ASTM Standards*, Vol 07.01.

³ Available from U.S. Government Printing Office, Washington, DC 20402.

³ *Annual Book of ASTM Standards*, Vol 07.02.

~~2.3 National Fire Protection Association (NFPA) Standards:~~
~~NFPA 701, Fire Tests for Flame-Resistant Textiles and Films Textiles (Vertical Test)³~~
~~F 1494 Terminology Relating to Protective Clothing⁴~~

3. Terminology

3.1 *Definitions*—For definitions of terms used in this test method, related to the combustion of textiles, refer to the terminology contained in Terminology F 4391. For definitions of terms used in this test method, related to protective clothing, refer to the terminology contained in Terminology F 1494. For definitions of terms used in this test method, related to textile issues, refer to the terminology contained in Terminology D 123.

3.2 *afterflame, n*—persistent flaming of a material after the ignition source has been removed.

3.3 *after-flame time, n*—the length of time for which a material continues to flame after the ignition source has been removed.

3.24 *afterglow, n*—a glow in a material after the removal of an external ignition source or after the cessation (natural or induced) of flaming of the material (see also *glow*).

3.35 *anisotropic, adj*—having different values for a specific property in different directions.

3.35.1 *Discussion*—When this test method is used to evaluate textile-based materials, this term refers to warp (wale) and filling (course) directions. When this test method is used for nonwoven materials, this term refers to machine and cross-machine directions.

3.46 *burning behavior, n*—all the changes that take place when materials or products are exposed to a specified ignition source.

3.57 *burn distance, n*—the measurement from the bottom edge of the specimen to the farthest point that shows evidence of damage due to combustion.

3.57.1 *Discussion*—In evaluating the effects of flame impingement of materials used in protective clothing, this measurement applies to the folded material specimen when pressed flat and includes all areas partially burned, charred, embrittled, or melted, but not including areas sooted, stained, distorted, or discolored. Damage due to mechanical delamination or splitting of the specimen is not included in the burn distance unless the delaminated or split area includes damage due to combustion.

3.68 *charring, n*—the formation of carbonaceous residue as the result of pyrolysis or incomplete combustion.

3.79 *combustion, n*—a chemical process of oxidation that occurs at a rate fast enough to produce heat and usually light either as glow or flames.

3.810 *dripping, n*—in testing thermal protective clothing, a material response as evidenced by flowing of the polymer.

3.810.1 *Discussion*—In evaluating the effects of flame impingement of materials used in protective clothing, dripping may be the formation of liquid droplets from melted surface or substrate material during flame impingement.

3.911 *embrittlement, n*—the formation of a brittle residue as the result of pyrolysis or incomplete combustion.

3.102 *flame, n*—~~as related to ignition of textiles~~, a controlled hot luminous zone of gas or matter in gaseous suspension, or both, of constant size and shape that is undergoing combustion as evidenced by a low-intensity heat source of less than 5 kW , such as a ~~burner candle flame on a gas stove~~.

~~3.10.1 or match flame.~~

3.12.1 *Discussion*—Examples are flames from a match, candle, or bunsen burner. The burner flame in this test method produces relatively low heat flux and should be constant in size and shape.

3.143 *flame impingement, n*—direct contact between a flame and a material.

3.143.1 *Discussion*—In testing flame impingement of materials used in protective clothing, the flame is of a specified type and duration.

3.124 *flammability, n*—those characteristics of a material that pertain to its ignition and support of combustion.

3.124.1 *Discussion*—In evaluating the effects of flame impingement of materials used in protective clothing, flammability is based on the relative number of specimens which ignite when exposed to flame either for a period of 3 or 12 s.

3.135 *glow, n*—visible, flameless combustion of the solid phase of a material.

3.135.1 *Discussion*—Although a solid may glow, it can also produce combustible discharge that will cause a flame. These two phenomena are not necessarily interdependent.

3.146 *ignition, n*—the initiation of combustion.

3.146.1 *Discussion*—In evaluating the effects of flame impingement of material used in protective clothing, ignition is determined by the presence of after-flame after the removal of the burner flame.

3.157 *melting, n*—~~in testing thermal protective clothing~~, a response to heat by a material resulting in evidence of flowing or dripping.

3.157.1 *Discussion*—In evaluating the effects of flame impingement of materials used in protective clothing, melting may occur at surface layers or in combination with the substrate fabric(s) or other polymer layers. Melting may be observed for protective clothing materials which involve a polymer coating or laminate combined with a normally flame-resistant fabric or substrate.

3.168 *protective clothing, n*—~~a product which is specifically designed and constructed for the intended purpose of~~

³ Available from National Fire Protection Association, Batterymarch Park, Quincy, MA 02269.

⁴ *Annual Book of ASTM Standards*, Vol 11.03.

~~protecting~~ isolating parts of the body from ~~contact with~~ a potential hazard; or as a barrier to prevent the body from being a source of contamination.

3.168.1 *Discussion*—In this test method the potential hazard is *flame impingement* on protective clothing where flame resistance is not the primary form of protection offered by that clothing.

3.179 *shrinkage, n*—a decrease in one or more dimensions of an object or material.

3.179.1 *Discussion*—In evaluating the effects of flame impingement, these changes in dimension are caused by heat from the flame source.

4. Summary of Test Method

4.1 A conditioned specimen of a protective clothing material is folded in half and placed in a sample holder with the folded edge suspended over a gas flame.

4.2 The specimen is exposed to the flame for a 3-s interval.

4.2.1 If the material ignites during this exposure, the after-flame time, afterglow time, and burn distance of the specimen are measured and reported. Any observations of burning behavior are also reported. The test is then terminated.

4.3 If the material does not ignite after the first exposure, the same specimen is exposed to the flame for a 12-s interval. The after-flame time, afterglow time, and burn distance of the specimen are measured and reported. Any observations of burning behavior are also reported.

4.4 An alternative procedure is provided for conducting the 12-s exposure only.

5. Significance and Use

5.1 This test method is intended to determine the ignition resistance and burning characteristics of materials used in protective clothing, where flame resistance is not the primary form of protection designated.

5.1.1 Flame resistance is a distinctive property of clothing items designated for isolating parts of the body from anticipated flame hazards. It is possible that protective clothing designated for isolation from other hazard, such as those for chemical or biological protection, neither have flame resistance nor isolate the wearer from flame hazards. This test method ~~should~~ can be used to evaluate the effects of flame impingement on protective clothing where flame resistance is not the primary objective of protection.

5.1.2 When flame resistance is the primary protection offered by the protective clothing, alternative test methods ~~should~~ can be used. ~~Recommended A test methods include Federal method that is useful for evaluating flame resistance of textiles is Test Method Standard 191A, 5903, National Fire Protection Association Standard 701, D 6413. Index D 4723 contains descriptions and Test Method D 123, guidance on other flammability test methods for textiles.~~

5.1.3 This test method is useful to determine the ignition resistance and burning characteristics of materials used in protective clothing not designated for flame resistance when the outer material surface is exposed to the flame. As such, it is particularly suited to protective clothing materials which are composed of different layers such as coated fabrics, laminates, or multilayer clothing systems.

5.2 Correlation of data from this test method with the ignition resistance and burning characteristics of protective clothing (not designated for flame resistance) under actual use conditions is not implied.

6. Apparatus

6.1 *Cabinet*,⁵ and accessories, fabricated in accordance with the requirements specified in Fig. 1, Fig. 2, and Fig. 3. Use galvanized sheet metal or other suitable metal.

6.1.1 Provide a means for suspending the sample holder that permits adjustment of its height for positioning the specimen over the burner. One means of suspending the sample involves modifying the hanger for the specimen holder shown in Fig. 1, in such a way that the hanger allows the specimen holder to be lowered or raised as required to accommodate the thickness of the specimens to be tested.

6.2 *Burner*, equipped with a variable orifice to adjust the flame height, a barrel having a 10-mm ($\frac{3}{8}$ -in.) inside diameter and a pilot light (Fig. 4).

6.2.1 One method for constructing the burner is to combine a 10-mm ($\frac{3}{8}$ -in.) inside diameter barrel 75 ± 6 mm ($3 \pm \frac{1}{4}$ in.) long from a fixed orifice burner with a base from a variable orifice burner.

6.2.2 Use a pilot light tube with an inner diameter of approximately 2 mm ($\frac{1}{16}$ in.) which is spaced 3 mm ($\frac{1}{8}$ in.) away from the burner edge.

6.2.3 Make the necessary gas connections and provide the applicable plumbing as specified in Fig. 5. Attach either a solenoid or stopcock to the burner. The control valve (stopcock or solenoid) shall be capable of being fully opened or fully closed in 0.1 s.

6.2.4 On the side of the barrel of the burner, opposite the pilot light, use a metal rod of approximately 3-mm ($\frac{1}{8}$ -in.) diameter spaced 13 mm ($\frac{1}{2}$ in.) from the barrel and extending above the burner. The rod shall have two 8-mm ($\frac{5}{16}$ -in.) prongs marking the

⁵ The test cabinet is available from U.S. Testing Co., 1941 Park Avenue, Hoboken, NJ 07030; or the Govmark Organization, Inc. P.O. Box 807, Bellmore, NY 11710. This is the same test cabinet specified in ~~FFMS 191A, 5903, Test Method D 6413.~~

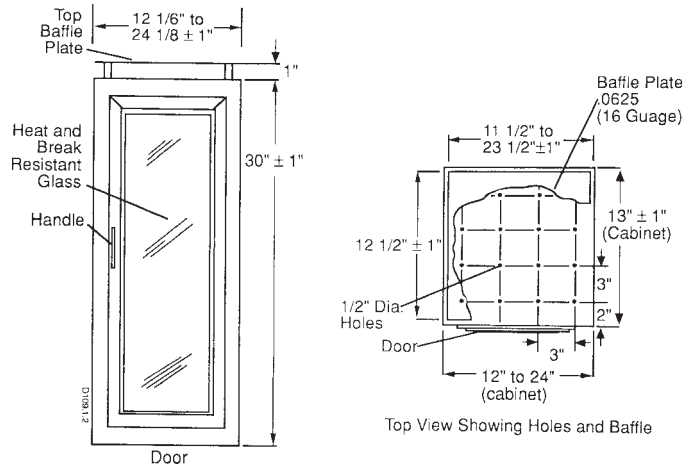

NOTE 1—All dimensions are in inches (1 in. = 25.4 mm).

FIG. 2 Cabinet Front and Top Detail

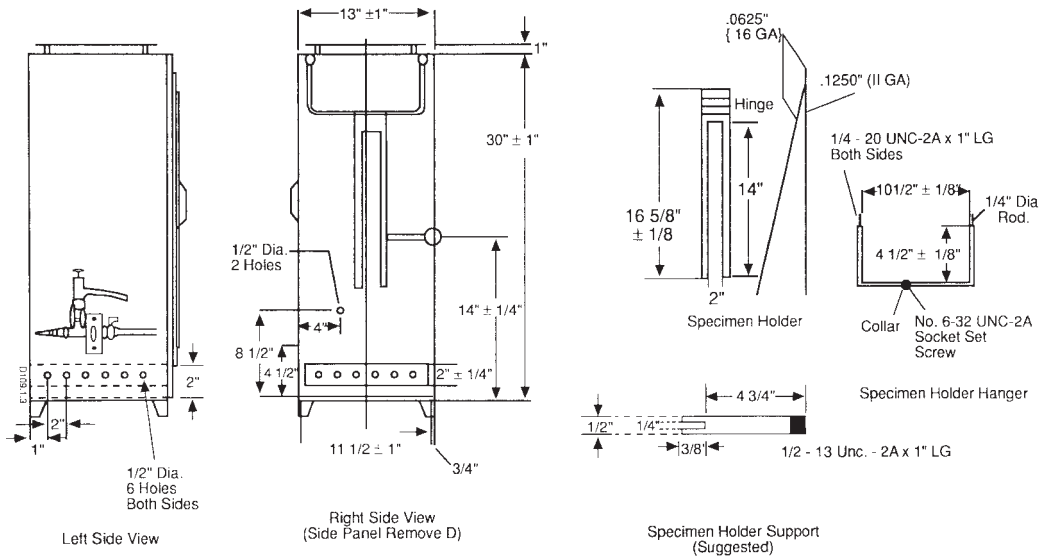

NOTE 1—All dimensions are in inches (1 in. = 25.4 mm).

FIG. 3 Other Cabinet Construction Details

distances of 19 mm (3/4 in.) and 38 mm (1 1/2 in.) above the top of the burner.

6.2.5 Fix the burner in a position so that the center of the barrel of the burner is directly below the center of the specimen.

6.3 *Gas Regulator Valve System*,⁶ with a control valve system with a delivery rate designated to furnish gas to the burner under a gage pressure of 17.2 ± 1.7 kPa ($2\frac{1}{2} \pm \frac{1}{4}$ psi) at the burner inlet. The manufacturer's recommended delivery rate for the valve system shall include the required pressure.

6.4 *Burner Gas*, methane, with a minimum purity of 99 %.

6.5 *Rod*, of 6-mm (0.25-in.) diameter, at least 152 mm (6 in.) long, constructed of a hard metal.

6.6 *Timer*, stopwatch or other timing device calibrated and graduated to the nearest 0.1 s.

6.7 *Ruler*, or scale calibrated and graduated to the nearest 1.0 mm (1/16 in.).

7. Test Specimens

7.1 Prepare ten test specimens 75 mm in width by 400 mm in length (3 in. by 16 in.). If the material is anisotropic, cut five specimens along each axis.

⁶ The regulator valve system is available from Matheson Gas Products, P.O. Box 85, East Rutherford, NJ 07073; or Air Products and Chemicals, Inc., P.O. Box 538, Allentown, PA 18105.

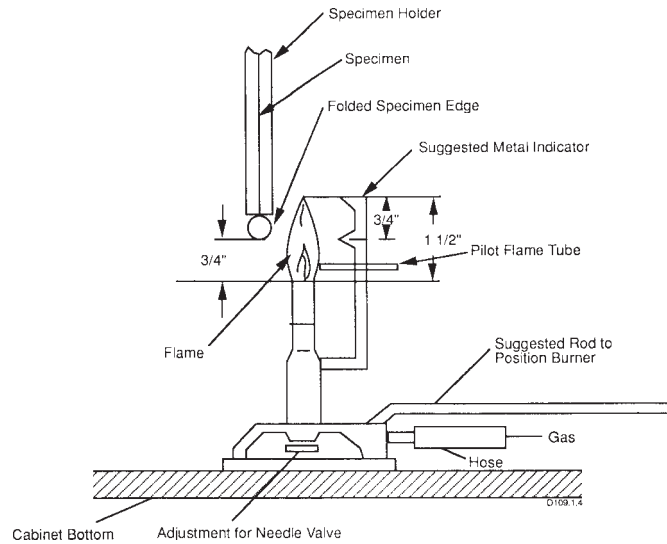

NOTE 1—The burner does not need to be resting on the cabinet bottom, but it is considered more convenient in this mode.

NOTE 2—All dimensions in inches are (1 in. = 25.4 mm).

FIG. 4 Burner and Positioning of the Test Specimen

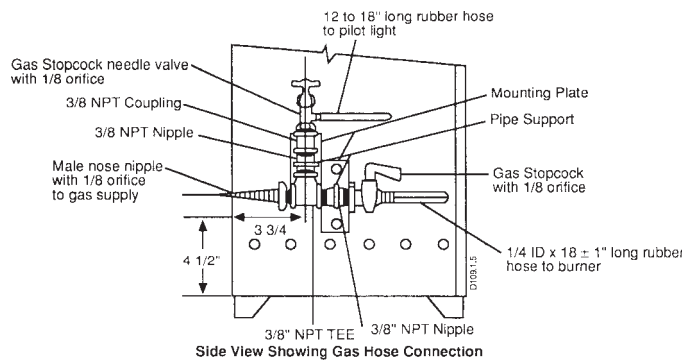

NOTE 1—All pipe fitting is to be black iron pipe.

NOTE 2—All dimensions are in inches (1 in. = 25.4 mm).

FIG. 5 Cabinet Gas Connections

8. Conditioning

8.1 Condition all samples to be tested at a relative humidity of 45 to 70 % and a temperature of 20 to 25°C (67 to 77°F) for at least 24 h prior to testing.

9. Procedure

9.1 Place the apparatus in a hood with the ventilating fan turned off at the time of the test.

9.2 Fold specimens in half across the width with the normal outside surface of the material facing out. Produce the fold with the metal rod at the bend inside the material. Avoid making permanent creases at the folded edge.

9.3 Place the material specimen in its holder. The folded edge of the specimen shall protrude approximately 6 mm (1/4 in.) below the lower horizontal end of the metal specimen clamp. Materials with different thicknesses will result in slightly different protrusion lengths from the end of the clamp. Remove the metal rod after the material is clamped in the holder.

9.3.1 Position the bottom edge of the specimen such that it is 19 mm (3/4 in.) above the top of the burner as shown in Fig. 4. This will require changes in the cabinet, involving the hanger for the specimen holder, to allow adjustment of the holder height for positioning the bottom edge of the specimen.

9.4 Ignite the pilot light and adjust its flame to approximately 3 mm (1/8 in.) in height as measured from its lowest point to the tip. Ignite and adjust the burner flame by means of the needle valve in the base of the burner to give a flame height of 38 mm (1 1/2 in.) with the stopcock fully open and the air supply to the burner shut off and taped. Obtain the 38-mm flame height by adjusting the valve so that the uppermost portion (tip) of the flame is level with the tip of the upper metal prong (see Fig. 4).

9.5 With the pilot light still on, shut off the gas to the burner with the stopcock or solenoid valve. Place the specimen holder over the specimen holder bar, held in position by the specimen holder support. Adjust the specimen holder bar to position the folded

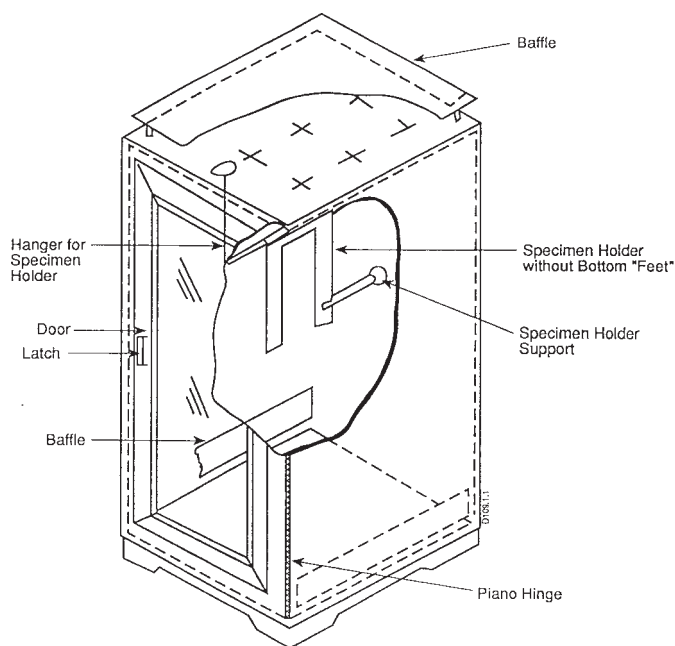

NOTE 1—The specimen holder may be positioned so that the specimen faces the door.

FIG. 1 Test Cabinet

edge of the specimen 19 mm ($\frac{3}{4}$ in.) above the top of the burner. Shut the cabinet door and keep it closed until all combustion of the specimen has ceased.

9.6 Simultaneously start the timer and open the stopcock to the regulated gas source. Apply the tip of the flame to the end of the folded edge of the specimen for 3 ± 0.1 s. At the end of this exposure, turn off the stopcock to the regulated gas source.

9.7 Observe and note whether or not the specimen ignites (A specimen is considered to have ignited when it continues to burn for more than 1.0 ± 0.1 s after turning off the gas supply to the flame). If the specimen ignites during the 3-s flame exposure:

9.7.1 Continue the test and stop the timer when no visible flame is present on the material specimen. Subtract 3 s from the measured time. Record this time as after-flame time. Also record the afterglow time, if observed.

9.7.2 Note the apparent cause of extinguishment such as shrinkage, destruction, or dripping.

9.7.3 After specimen burning ceases, turn on the hood ventilation fan to clear the hood of combustion gases.

9.7.4 Measure the burn distance on the specimen after the 3-s flame exposure. Record the burn distance to the nearest 1 mm ($\frac{1}{8}$ in.). Wiping the material specimen with a damp cloth or paper towel helps to more clearly determine the burn distance.

9.7.5 Do not continue any testing on the specimen.

9.8 If the specimen does not ignite after the 3-s flame exposure:

9.8.1 Restart the stopwatch from zero and reapply the flame to the folded edge of the same specimen at the same location used in the 3-s exposure for an additional 12 ± 0.1 s. The time interval between flame exposures shall be 4 ± 1 s.

9.8.2 Allow the stopwatch to keep running. Observe and note whether or not the specimen ignites (a specimen is considered to have ignited when it continues to burn for more than 1.0 ± 0.1 s after turning off the gas supply to the flame). Stop the timer when no visible flame is present on the material specimen. Subtract 12 s from the measured time. Record this time as after-flame time. Also record the afterglow time, if observed.

9.8.3 Note the apparent cause of extinguishment such as shrinkage, destruction, or dripping.

9.8.4 After specimen burning ceases, turn on the hood ventilating fan to clear the hood of combustion gases.

9.8.5 Measure the burn distance on the specimen after the 12-s flame exposure. Record the burn distance to the nearest 1 mm ($\frac{1}{8}$ in.). Wiping the material specimen with a damp cloth or paper towel helps to more clearly determine the burn distance.

9.9 Alternative Test Procedure—As alternative to the procedures provided in 9.1-9.8.5, conduct the test using a 12-s flame exposure only. Follow the steps in 9.1-9.5. Skip the 3-s exposure steps in 9.6 and 9.7, and begin with the 12-s exposure described in 9.8.

10. Test Results

10.1 *Flammability*—Note flammability as the number of specimens igniting during the 3-s flame exposure period, the number of specimens igniting during the subsequent 12-s flame exposure period, and the number of specimens not igniting at all.

10.2 *After-flame Time*—Measure after-flame time as the time, reported in seconds, from the moment that the operator removes the flame from the specimen until no visible flame is present on the material specimen.

10.3 *Afterglow Time*—Measure the afterglow as the time, reported in seconds, that the specimen glows. If present, afterglow is observable either immediately after the removal of the flame from the specimen or after sample burning has ceased (after-flame time).

10.4 *Burn Distance*—Measure the burn distance in millimetres (inches) from the bottom edge of the material specimen to the farthest vertical point on the folded specimen, when pressed flat, that is burned in the test following the respective flame exposure period. This includes all areas of the specimen which are partially burned, charred, embrittled, or melted, but not areas sooted, stained, distorted, or discolored. Do not include damage due to mechanical delamination or splitting of the specimen in the measurement of burn distance unless the delaminated or split area includes damage due to combustion.

10.5 *Burning Behavior*—Note the burning behavior of the specimen for the samples that ignite. This shall include observations of specimen shrinkage, destruction, melting, or dripping.

10.5.1 Some materials shrink away from the flame without ignition and it is possible that subsequent reexposure of the same specimen does not produce direct contact with the flame source. As a consequence, it is possible that a relatively short after-flame time or small burn distances is measured. Record this phenomenon as a characteristic of the material specimen, when observed.

11. Report

11.1 Report that the specimens were tested as described in Test Method F 1358. Identify the protective clothing material tested and note the manufacturer or source of the material and its application. Provide a description of the material noting which surface was exposed to the flame.

11.2 For each specimen tested, report the following measurements and observations.

11.2.1 *Flammability*:

11.2.1.1 Ignition noted during 3-s flame exposure period,

11.2.1.2 Ignition noted during 12-s flame exposure period, or

11.2.1.3 Did not ignite in either flame exposure period.

11.2.2 After-flame time, afterglow time, and burn distance if specimen ignites during 3-s flame exposure period.

11.2.3 After-flame time, afterglow time, and burn distance if specimen ignites during 12-s flame exposure period.

11.2.4 Specific observations of burning behavior including specimen shrinkage, destruction, or dripping.

11.3 For each material tested, report the following:

11.3.1 Number of test specimens igniting during the first 3-s flame exposure period,

11.3.2 Number of test specimens igniting during subsequent 12-s flame exposure period,

11.3.3 Number of test specimens not igniting in either flame exposure period, and

11.3.4 Average burning characteristics following 3-s exposure as follows:

11.3.4.1 Average after-flame and afterglow times, and

11.3.4.2 Average burn distance.

11.3.5 Average burning characteristics following 12-s exposure:

11.3.5.1 Average after-flame and afterglow times, and

11.3.5.2 Average burn distance.

11.3.6 Observations of material burning behavior including specimen shrinkage, destruction, or dripping.

11.4 If the alternative test procedure for this test method is used, indicate in the report that the alternative test procedure was used with a 12-s exposure only. Report required test information from 11.2 and 11.3 for the 12-s exposure only.

12. Precision and Bias

12.1 *Precision*—

12.1.1 *Single Laboratory Study*—Three chemical protective clothing fabrics were tested in one laboratory, using one operator to determine if the specimen ignited during the first 3-s flame exposure period, if the specimens ignited during the subsequent 12-s flame exposure period, afterflame time, and burn distance measured on each specimen by the procedure. Ten specimens were taken from each fabric sample, five in the lengthwise (machine) direction and five in the widthwise (cross-machine) direction. This single-laboratory set is analyzed and used in writing a temporary precision statement, pending a full interlaboratory study. Until the full study is completed, users of this test method are advised to exercise conventional statistical caution in making any comparisons of the test results. Table 1 provides a summary of test data for the materials tested, while Table 2 and Table 3 provide a with-in laboratory (repeatability) critical differences for afterflame a time and burn distance. (The critical difference is the observed difference between two test results, which should be considered significant at the specified probability level, as defined in Terminology D 123).

12.1.2 *Specimen Ignition*—Since observations are used to determine whether specimens ignited in either the 3-s or 12-s flame exposure periods, the information for the three materials is reported in Table 1.

12.1.3 *Afterflame Time*—Variances for the lengthwise and widthwise specimens are similar, ranging in value from 0.38 to 0.49, with an average value of 0.43 s² (standard deviation = 0.078) as determined by analysis of variance. Critical differences, based on this value and a 95 % probability level, may be applied either to lengthwise average comparisons, or to widthwise average comparisons, to determine significance.

12.1.4 *Burn Distance*—Variances for the lengthwise and widthwise specimens are similar, ranging in value from 0.12 to 0.32,

TABLE 1 Single Laboratory Study Data

Material	Direction	No. Specimens Igniting		Specimens Not Igniting in 3-s and 12-s Exposures	Average Afterflame (s)	Average Burn Distance (mm)
		After 3-s Exposure	After 12-s Exposure			
A	Lengthwise	0	0	5	0	1.0
	Widthwise	0	0	5	0	1.3
B	Lengthwise	0	0	5	0	16.4
	Widthwise	0	0	5	0	15.2
C	Lengthwise	0	5	0	5.8	12.6
	Widthwise	0	5	0	9.8	18.8

TABLE 2 Repeatability or Within-Laboratory Critical Differences

Afterflame Time (s) (95 % Probability Level)		
N ^A	SE ^B	CD ^C
1	0.078	0.218
3	0.045	0.126
5	0.034	0.095
7	0.029	0.081

^A N = Number of determinations per average

^B SE = Standard Error for N determinations

^C CD = 2.8 SE

TABLE 3 Repeatability or Within-Laboratory Critical Differences

Burn Distance (mm) (95 % Probability Level)		
N ^A	SE ^B	CD ^C
1	0.095	0.266
3	0.054	0.154
5	0.042	0.118
7	0.036	0.100

^A N = Number of determinations per average

^B SE = Standard Error for N determinations

^C CD = 2.8 SE

with an average value of 0.21 mm²(standard deviation = 0.095) as determined by analysis of variance. Critical differences, based on this value and a 95 % probability level, may be applied either to lengthwise average comparisons, or to widthwise average comparisons, to determine significance.

12.2 *Bias*—There is no accepted referee method for determining the true value of ignition resistance and burning behavior of protective clothing materials not designated for flame resistance. The value may be defined only in terms of a test method. This test method has no known bias.

13. Keywords

13.1 burning behavior; flame impingement; ignition; protective clothing

ASTM International takes no position respecting the validity of any patent rights asserted in connection with any item mentioned in this standard. Users of this standard are expressly advised that determination of the validity of any such patent rights, and the risk of infringement of such rights, are entirely their own responsibility.

This standard is subject to revision at any time by the responsible technical committee and must be reviewed every five years and if not revised, either reapproved or withdrawn. Your comments are invited either for revision of this standard or for additional standards and should be addressed to ASTM International Headquarters. Your comments will receive careful consideration at a meeting of the responsible technical committee, which you may attend. If you feel that your comments have not received a fair hearing you should make your views known to the ASTM Committee on Standards, at the address shown below.

This standard is copyrighted by ASTM International, 100 Barr Harbor Drive, PO Box C700, West Conshohocken, PA 19428-2959, United States. Individual reprints (single or multiple copies) of this standard may be obtained by contacting ASTM at the above address or at 610-832-9585 (phone), 610-832-9555 (fax), or service@astm.org (e-mail); or through the ASTM website (www.astm.org).