

This document is not an ASTM standard and is intended only to provide the user of an ASTM standard an indication of what changes have been made to the previous version. Because it may not be technically possible to adequately depict all changes accurately, ASTM recommends that users consult prior editions as appropriate. In all cases only the current version of the standard as published by ASTM is to be considered the official document.



Designation: D 5633 – 94 (Reapproved 2001)



Designation: D 5633 – 04

Standard Practice for Sampling with a Scoop¹

This standard is issued under the fixed designation D 5633; the number immediately following the designation indicates the year of original adoption or, in the case of revision, the year of last revision. A number in parentheses indicates the year of last reapproval. A superscript epsilon (ε) indicates an editorial change since the last revision or reapproval.

¹ This practice is under the jurisdiction of ASTM Committee D34 on Waste Management and is the direct responsibility of Subcommittee D34.01.03 on Sample Preservation.

Current edition approved ~~Nov. 15, 1994~~, April 1, 2004. Published ~~May 2004~~, May 2004. Originally approved in 1994. Last previous edition approved in 1994 as D 5633-94(2001).

1. Scope

1.1 This procedure covers the method and equipment used to collect surface and near-surface samples of soils and physically similar materials using a scoop.

1.2 *This standard does not purport to address all of the safety concerns, if any, associated with its use. It is the responsibility of the user of this standard to establish appropriate safety and health practices and determine the applicability of regulatory limitations prior to use.*

2. Referenced Documents

2.1 *ASTM Standards:*²

D 4687 Guide for General Planning of Waste Sampling

D 5088 Practice for Decontamination of Field Equipment Used at Nonradioactive Waste Sites

D 5283 Practice for Generation of Environmental Data Related to Waste Management Activities: Quality Assurance and Quality Control Planning and Implementation

D 5792 Practice for Generation of Environmental Data Related to Waste Management Activities: Development of Data Quality Objectives

D 6044 Guide for Representative Sampling for Management of Waste and Contaminated Media

D 6232 Guide for Selection of Sampling Equipment for Waste and Contaminated Media Data Collection Activities

2.2 *Other Documents:*

Pierre Gy's Sampling Theory and Sampling Practice, Francis F. Pitard³

3. Summary of Practice

3.1 The top layers of material are removed down to the required sample depth using a shovel or other suitable equipment. A clean scoop is then used to collect the actual sample, which is placed in a sample container.

4. Significance and Use

4.1 This practice is intended for use in collecting samples of contaminated soils and similar materials.

4.2 Scoops are used primarily for collecting samples near the surface. Subsurface samples can be obtained by first removing higher layers using a shovel or other suitable equipment and collecting the sample with the scoop.

4.3 Because of their simplicity, scoops are useful in taking samples of waste materials where decontamination or disposal is a problem with other types of sampling equipment. Scoops are also suitable for use in rapid screening programs, pilot studies, and other semi-quantitative investigations.

4.4 Samples should be collected in accordance with an appropriate work plan (see Practice D 5283 and Guide D 4687).

5. Sampling Equipment

5.1 A shovel or other suitable equipment can be used for the initial removal of overburden material. This equipment should be manufactured from material that is compatible with the soil or waste to be sampled. The scoop must be manufactured from material that is compatible with the soil or waste to be sampled and the required test or analysis to be performed. For most hazardous waste sampling, either a disposable plastic scoop or a reusable stainless steel or polytetrafluoroethylene-coated scoop is suitable (see Guide 6232 and Practice 5792).

² For referenced ASTM standards, visit the ASTM website, www.astm.org, or contact ASTM Customer Service at service@astm.org. For *Annual Book of ASTM Standards*, Vol. 11.04, volume information, refer to the standard's Document Summary page on the ASTM website.

Annual Book of ASTM Standards, Vol. 04.09.

³ Available from CRC Press, Inc., 2000 Corporate Blvd., NW, Boca Raton, FL 33431.

5.2 The design of the scoop is important to minimize sampling error, that is, all the material intended as the sample can be collected and placed in the sample container and is not lost as the scoop is systematically lifted from the source to the sample container (see Guide D 6044, Pierre Gy's Sampling Theory and Sampling Practice and Fig. 1).

5.3 For measurement of sample depth, a ruler or tape measure can be used.

5.4 The advantages of sampling with a scoop are that the scoops are:

5.4.1 inexpensive,

5.4.2 easy to use, and

5.4.3 easy to clean.

5.5 The limitations associated with sampling with a scoop are that the scoop may:

5.5.1 affect the matrix during sample collection by selecting certain particle sizes,

5.5.2 not be constructed in a shape that is compatible with the dimensions of the matrix, and

5.5.3 may exacerbate the loss of volatile organic compounds by disturbance of the sample.

6. Sample Containers

6.1 Plastic, glass, or other nonreactive containers should be used. Refer to Guide D 4687 for information on sample containers.

7. Procedure

7.1 Record all relevant information and observations about the sample location.

7.2 Use a shovel or other suitable equipment to remove any overburden material down to the level specified in the work plan.

7.3 Measure to the depth at which the sample will be collected with a ruler or tape measure. Record this information in the field log book.

7.4 Remove the thin layer of material that was in contact with the overburden removal equipment and discard it using a clean scoop. The work plan will define if the scoop may or may not be reused to collect the actual sample.

7.5 To collect a representative sample, the scoop should be pushed through the material with its base parallel to the material's surface. The scoop should enter one side of the material and completely exit the other side, where possible. Once the sample is in the scoop, the scoop should be lifted vertically taking care not to lose any sample out the front or over the sides and back of the scoop.

7.6 Collect a suitable volume of sample with the scoop (the same scoop can be used to collect multiple scoopfuls to obtain sufficient volume to fill the container). Use a new (or decontaminated) scoop for each sample. Transfer the sample into the suitable container. Close the sample container and complete and attach the sample label.

7.6.7 Complete the field log book and chain-of-custody form.

7.7.8 Decontaminate the reusable equipment in accordance with the protocol specified in the work plan (see Practice D 5088).

8. Keywords

8.1 sampling; scoop; soil sampling; waste

ASTM International takes no position respecting the validity of any patent rights asserted in connection with any item mentioned in this standard. Users of this standard are expressly advised that determination of the validity of any such patent rights, and the risk of infringement of such rights, are entirely their own responsibility.

This standard is subject to revision at any time by the responsible technical committee and must be reviewed every five years and if not revised, either reapproved or withdrawn. Your comments are invited either for revision of this standard or for additional standards and should be addressed to ASTM International Headquarters. Your comments will receive careful consideration at a meeting of the responsible technical committee, which you may attend. If you feel that your comments have not received a fair hearing you should make your views known to the ASTM Committee on Standards, at the address shown below.

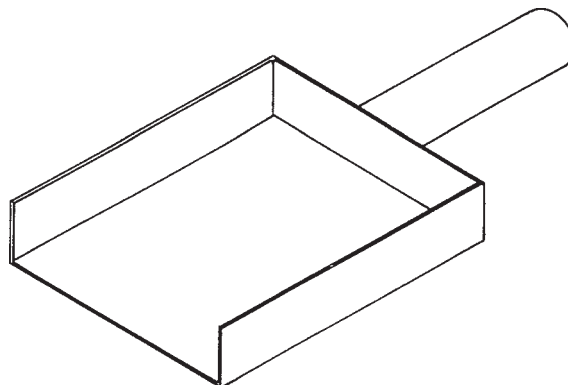

FIG. 1 Example of a Scoop

This standard is copyrighted by ASTM International, 100 Barr Harbor Drive, PO Box C700, West Conshohocken, PA 19428-2959, United States. Individual reprints (single or multiple copies) of this standard may be obtained by contacting ASTM at the above address or at 610-832-9585 (phone), 610-832-9555 (fax), or service@astm.org (e-mail); or through the ASTM website (www.astm.org).