



Designation: F 1084 – 90 (Reapproved 2001)

Standard Guide for Sampling Oil/Water Mixtures for Oil Spill Recovery Equipment¹

This standard is issued under the fixed designation F 1084; the number immediately following the designation indicates the year of original adoption or, in the case of revision, the year of last revision. A number in parentheses indicates the year of last approval. A superscript epsilon (ε) indicates an editorial change since the last revision or reapproval.

1. Scope

1.1 This guide is intended for sampling flowing or stationary oil/water mixtures. It is intended for use with oil spill recovery devices either in testing or in documentation of field performance.

1.2 *This standard does not purport to address all of the safety concerns, if any, associated with its use. It is the responsibility of the user of this standard to establish appropriate safety and health practices and determine the applicability of regulatory limitations prior to use.*

2. Referenced Documents

2.1 ASTM Standards:

D 1744 Test Method for Water in Liquid Petroleum Products by Karl Fischer Reagent²

D 1796 Test Method for Water and Sediment in Fuel Oils by the Centrifuge Method (Laboratory Procedure)²

F 625 Practice for Classifying Water Bodies for Spill Control Systems³

3. Significance and Use

3.1 This guide provides techniques for obtaining representative samples of oil and water mixtures. This information is necessary in the calculation of oil recovery efficiency and oil recovery rates for oil collection devices.

3.2 *Sampling Stationary Mixtures*—When recovered oil/water mixtures are contained within a holding tank and the relative oil content of the recovered fluid is needed, the sampling technique is somewhat dependent on the container. Two techniques are outlined in this guide. If the container has a flat bottom with straight sides perpendicular to the base (or nearly so), either stationary technique can be implemented, with the stratified sampling method preferred. If the container is irregular in either the horizontal or vertical cross section, the mixing method is preferred.

3.3 *Sampling Flowing Mixtures*—To sample flowing mixtures containing both oil and water, turbulence is induced, to

create a homogenous mixture while sampling. The oil content in the sample taken from the flowing stream can then be used to quantify the performance rating criterion (see Procedure Section of Test Method D 1796).

4. Number of Samples

4.1 Take a minimum of four samples under each set of conditions to average results and store the samples separately. In less ideal sampling conditions, take additional samples.

5. Containers

5.1 A dry, water-washed glass sample container.

6. Labeling

6.1 Mark the sample container with the source, type of oil, date and time of sampling, the name of the person taking the sample, and a sample number. Require water and oil-resistant labeling. If several receiving containers are to be sampled, they must be identified and the samples marked for later coordination.

7. Preservation and Storage

7.1 The samples do not require special treatment to preserve their integrity other than ensuring that they remain sealed until analyzed. Note date and time of analysis for each sample.

8. Procedure

8.1 *Baseline Data*—The test fluids may be crude, refined, or synthetic oils. Record type, specific gravity, viscosity, and temperature of each oil together with the environmental conditions (see Practice F 625), air temperature, and slick thickness beyond the influence of the recovery equipment for each test point.

8.2 *Sampling from a Container*—This procedure is intended for taking a representative sample of collected fluids held in a container. When sampling containers, it is advisable to remove as much of the aqueous phase as possible prior to sampling. If this is possible, measure and record the volume of water removed, which will contain dissolved hydrocarbons, for later calculation of the relative oil/water composition. The precision of the measurement will improve with removal of the aqueous phase.

8.2.1 Mixing Method:

8.2.1.1 Mix the container of stratified oil and water using

¹ This guide is under the jurisdiction of ASTM Committee F20 on Hazardous Substances and Oil Spill Response and is the direct responsibility of Subcommittee F20.12 on Removal.

Current edition approved May 25, 1990. Published July 1990. Originally published as F 1084 – 87. Last previous edition F 1084 – 87.

² *Annual Book of ASTM Standards*, Vol 05.01.

³ *Annual Book of ASTM Standards*, Vol 11.04.

any method which will achieve homogeneity during sampling (high-speed propeller, liquid jet, or homogenizing pump). Operate the mixer for a minimum of 5 min. Longer mixing times are preferable to ensure homogeneity.

NOTE 1—Although this mixing method has been geared toward electric mixers, alternate mixing methods could be used (air or liquid mixing jets, homogenizing pumps), so long as a homogeneous mixture of the entire volume is created. Immediately after mixing, obtain a representative sample of the homogeneous mixture by lowering a 250 to 500-mL small-mouthed bottle (from which the cap has been removed) at a constant slow rate from the surface of the mixture to the bottom of the tank. Immediately remove the bottle by slowly raising it through the mixture. If necessary, repeat the process to ensure that at least 50 mL of sample will be available for laboratory analysis. Do not fill the bottle to the top.

8.2.1.2 *Limitations*—The size of the sampled fluid container is limited by the mixing capability available for thoroughly homogenizing the oil and water. Mixtures where the relative oil content is less than 20 % probably will not form a stable emulsion for sampling; making this method inappropriate for these mixtures.

NOTE 2—Certain oils (*N*-dimethylformamide, military jet engine fuel, DMF, JP5) will not form stable emulsions. Speed is important in these cases as the homogeneity of the mixture diminishes rapidly.

8.2.2 *Nonmixing Method:*

8.2.2.1 Where recovered oil/water mixtures cannot be homogenized or the emulsion formed is not easily broken, insert a stratified sampler into the nonmixed fluids to obtain a cross section of the fluids. Construct the stratified sampler as shown in Fig. 1.

8.2.2.2 *Stratified Mixture Sampling*—Place the entire sampler within the mixture to be sampled, with the outer sheath in the raised (open) position to expose the inner core. Lower the outer sheath to capture a set of samples in the annular segments. Remove the entire sampler, wipe clean, and drain each sample container through a clean funnel.

8.2.2.3 *Limitations*—Sampling with this device limits the size of the sampled tank. The physical workings of the sampler dictate that the tank cannot be greater in depth than the height which the sample taker can comfortably reach above the top of the tank. Movement of the tank can give nonrepresentative samples because of the rolling oil/water interface. Use on small vessels in the high seas requires that additional samples be taken and results averaged. The sampler must be thoroughly cleaned between sample takings.

NOTE 3—If the container is irregular in vertical cross section, the segments within the sample should not be analyzed as a whole. Each segment must be analyzed separately and averaged on a representative-volume-weight basis. Each segment must be large enough to capture a 50 mL sample for analysis.

8.3 *Sampling from a Flow*—When it is necessary to sample a flowing stream, eliminate the possibility of multilayer or stratified flow and bring the stream into a turbulent flow condition.

8.3.1 Position a static mixer (sometimes called an in-line or motionless mixer) in the skimmer discharge by-pass line, on the high-pressure side of the recovery pump. Immediately after the static mixer, install a sampling port shaped like a fixed Pitot tube (see Fig. 2) at the pipe center. It should be accessible and easy to use. Specify the static mixer to produce dispersed

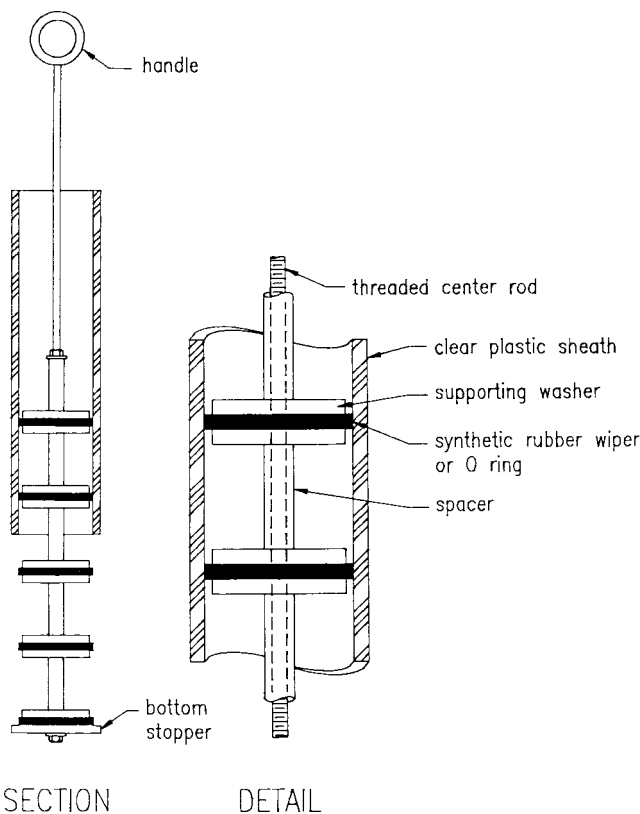

NOTE 1—Align holes on slots in inner and outer sleeve to let sample into zones of the sampler. When sampler is closed, holes are covered and sampler is secured.

FIG. 1 Stratified Sampler with Construction Details

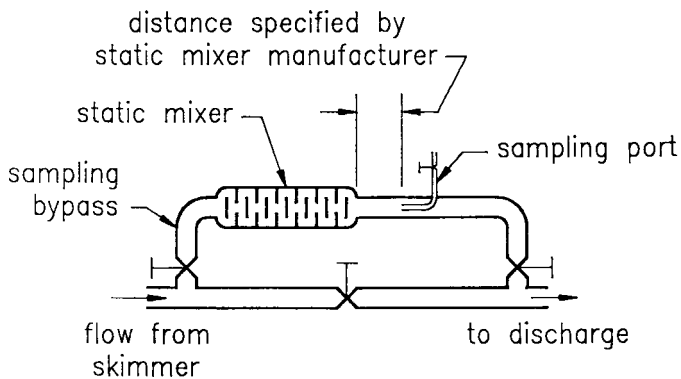

FIG. 2 Sampling Bypass

droplets having a mean droplet diameter of approximately 2000 μm at the expected flow rate and oil content. This method will provide a representative sample which can be used to determine the percentage of oil in the flowing oil/water mixture encountered.

NOTE 4—Because this is a measurement taken over a short time interval, it must be considered to be a differential measurement and many samples must be taken to ensure validity, especially in the start up portion of the oil recovery operation when conditions are rapidly changing.

NOTE 5—Although this method requires many samples to be taken, it is advisable not to keep the sampling port in constant operation. The mixed fluids are, by choice, a dispersion which should separate readily, but the intentional mixing of the recovered oil and water should be avoided in

 **F 1084**

ongoing oil recovery operation. The mixing elements within the mixer may also cause a significant pressure drop which may be deleterious to skimmer performance. The mixer will be sensitive to debris, particularly string-like debris (sorbant, seaweed, fishing line) that will tend to wrap around the elements. The use of a by-pass parallel to the main flow is recommended.

NOTE 6—Sampling ports, lines, or by-passes, should be purged for a suitable time before actual samples are taken.

9. Procedure for Determining Percent of Oil in Mixture by Instruction or Reference

9.1 Refer to Test Method D 1744.

10. Accuracy

10.1 *Stationary Mixtures*—These procedures have been developed with known oil/water mixtures in flat-bottom containers holding less than 2 m³ of mixture.

10.1.1 *Mixing Method*—The comparison of the known oil content to that determined using the mixing method yielded a maximum difference of 6 % and an average difference of 2 %. The known oil content error was approximately 1 %. The mix method will yield results within 7 %.

10.1.2 *Stratified Method*—The comparison of known oil content to the determined oil content yielded a maximum difference of 6 % and an average of 2 %. When the stratified mixture is sampled without free-standing water removal, the analysis is considered to be accurate within 4 %.

10.2 *Flowing Mixtures*—The difference between the oil content determined with a sample of the total flow by the mixing method and the oil content determined by averaging the Pitot tube sample results was 4 %. The maximum difference was 7 %, which is considered to be the limit of the accuracy in the method.

NOTE 7—These procedures (refer to Test Method D 1744) have been confirmed with known oil content ranging from 10 % to 90 %, but have not undergone complete round-robin testing. The differences between known oil content and analyzed oil content include the errors of sampling technique, sample retrieval, and sample analysis.

11. Keywords

11.1 oil spill; oil spill recovery; oil/water mixtures

The ASTM International takes no position respecting the validity of any patent rights asserted in connection with any item mentioned in this standard. Users of this standard are expressly advised that determination of the validity of any such patent rights, and the risk of infringement of such rights, are entirely their own responsibility.

This standard is subject to revision at any time by the responsible technical committee and must be reviewed every five years and if not revised, either reapproved or withdrawn. Your comments are invited either for revision of this standard or for additional standards and should be addressed to ASTM International Headquarters. Your comments will receive careful consideration at a meeting of the responsible technical committee, which you may attend. If you feel that your comments have not received a fair hearing you should make your views known to the ASTM Committee on Standards, at the address shown below.

This standard is copyrighted by ASTM International, 100 Barr Harbor Drive, PO Box C700, West Conshohocken, PA 19428-2959, United States. Individual reprints (single or multiple copies) of this standard may be obtained by contacting ASTM at the above address or at 610-832-9585 (phone), 610-832-9555 (fax), or service@astm.org (e-mail); or through the ASTM website (www.astm.org).