

This document is not an ASTM standard and is intended only to provide the user of an ASTM standard an indication of what changes have been made to the previous version. Because it may not be technically possible to adequately depict all changes accurately, ASTM recommends that users consult prior editions as appropriate. In all cases only the current version of the standard as published by ASTM is to be considered the official document.



---

**Designation: E 1073 – 91 (Reapproved 1996)**



**Designation: E 1073 – 01**

## Standard Test Method for Obtaining a Pharmacological Profile with Mice<sup>1</sup>

This standard is issued under the fixed designation E 1073; the number immediately following the designation indicates the year of original adoption or, in the case of revision, the year of last revision. A number in parentheses indicates the year of last reapproval. A superscript epsilon ( $\epsilon$ ) indicates an editorial change since the last revision or reapproval.

<sup>1</sup> This test method is under the jurisdiction of ASTM Committee E-35 on Pesticides and is the direct responsibility of Subcommittee E35.26 on Safety to Man. Current edition approved ~~March 15, 1991~~, Oct. 10, 2001. Published ~~May 1991~~, November 2001. Originally published as E 1073 – 85. Last previous edition E 1073 – 891 (1996).

### 1. Scope

1.1 This test method is designed as a simple and inexpensive initial screening procedure for new compounds with unknown pharmacological properties, or for the comparative bioassay of new members of a chemical series with class reference standards. The test method, which is applicable to most pharmacologically active compounds including pesticides, will properly rank order both acute lethality and potency with a minimum expenditure of test material. It is intended as the first step in a multi-tiered development program.

1.2 *This standard does not purport to address all of the safety concerns, if any, associated with its use. It is the responsibility of the user of this standard to establish appropriate safety and health practices and determine the applicability of regulatory limitations prior to use.*

### 2. Summary of Test Method

2.1 Mice are injected intravenously with a dose of the test material and then observed for reaction signs, first those that can be detected by nonmanipulative tests, and then those sensed during a series of manipulative tests.

2.2 Two technicians are required to perform the experiment. One injects the mice and records the data, while the other conducts the experiment at regularly scheduled time intervals and dictates the findings.

2.3 The results obtained using this procedure indicate the approximate median lethal dose (LD50), the approximate median level of nonlethal reactions (MED50), the reaction signs elicited at each dose level tested, and the degree of severity of those signs. In contrast to the more commonly used median effective dose (ED50), the MED50 value may have been generated by one or more responses at the same dose, and thus does not imply the 50 % level for a specific reaction sign.

2.4 By judicious selection of acceptance criteria, the elimination rate for compounds tested using this procedure can be tailored to any desired level.

### 3. Significance and Use

3.1 This test method is designed as an initial screening procedure for the selection of compounds worthy of more detailed study.

3.2 This test method is applicable to the study of most drugs and chemicals, and will properly estimate both lethal and minimally effective dose levels. Although it is designed for the study of single components, it can be used to study the comparative toxicity of mixtures or formulations. The method may not be applicable to oily substances which cause embolism upon injection.

3.3 This test method requires only small quantities of test materials (approximately 1 g), a fact that enhances its utility as the initial biological study for newly synthesized substances.

3.4 It is equally economical in its requirements for equipment, space, personnel, and animals. Only a small laboratory, simple test equipment, and two technicians are needed to conduct the experiments. Furthermore, an average of only thirty mice are required to conduct the entire test method.

3.5 The procedure is applicable to a wide variety of materials. When results of this test were compared with those from more detailed and specific animal tests, a high degree of correlation was obtained. Further evidence of the utility of the test was demonstrated by the fact that a high correlation of rank order potencies was found for a series of anticholinergics studied in both mice and men.

### 4. Apparatus

4.1 All of the apparatus used for this test method is simple and inexpensive. It can be made in any well-equipped laboratory workshop or, in some cases, obtained commercially.

4.2 The major components of the apparatus are illustrated in Figs. 1-5.

4.3 *Syringes and Needles:*

4.3.1 One-quarter milliliter glass Tuberculin syringes, fitted with 0.75 in. (19 mm), 27-gage needles are recommended for

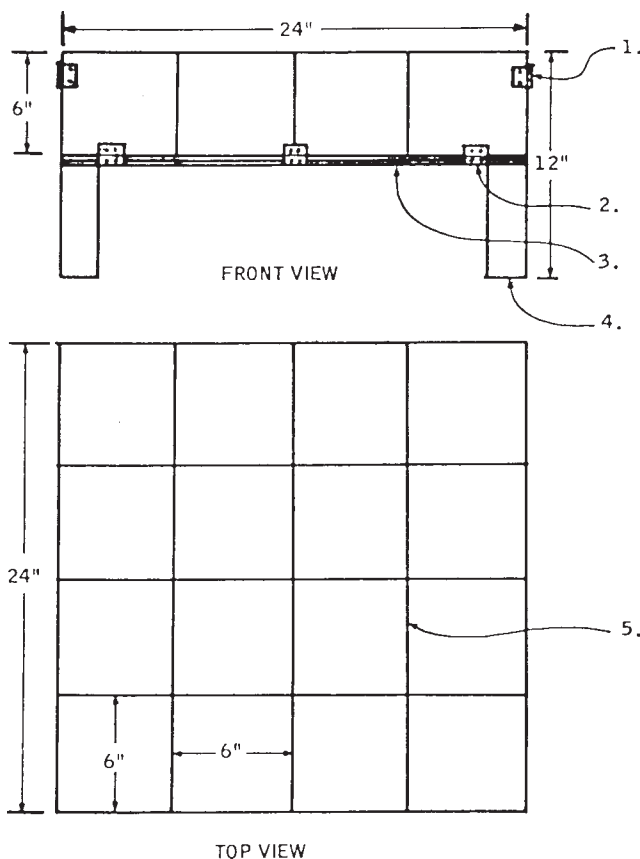

1. Hinge with easily removed pin.
2. Permanent hinge.
3. 24 by 24-in. plywood base with Lucite covering.
4. 2 by 6 by 24 in. long.
5. 6 in. high, 1/4 in. thick Lucite divider, interlocked in egg-crate manner.

**FIG. 1 Observation Platform**

injection of all solutions except undiluted polyethylene glycol (PEG) solutions. In the latter case, 24-gage needles must be used to compensate for the viscosity of the solvent, and 50- $\mu$ L syringes<sup>2,3</sup> are required to measure accurately the small volumes that are administered.

4.3.2 Although disposable syringes could be used for most of this work, calibrations on the glass syringes are more accurate. Furthermore, the possibility of a reaction between the plastic or rubber parts of disposable syringes with the test solutions, especially those containing PEG, exists.

## 5. Solvents

5.1 Any of the following solvents can be used up to the volumes shown for this test method if necessary. Usually, one of the first four is used for testing solids. Methylcellulose<sup>4,3</sup> solutions are used to prepare suspensions, not true solutions. The test material is finely ground using an agate mortar and pestle before suspending it.

<sup>2</sup> Hamilton Microliter syringes with stainless steel plunger using detachable needles available from Hamilton Co., P.O. Box 10030, Reno, NV have been found suitable for this purpose.

<sup>3</sup> Methocel®-4000 cps, Type F4M available from Dow Chemical Co., Midland, MI has been found suitable for

<sup>3</sup> This is the sole source of supply of the apparatus known to the committee at this time. If you are aware of alternate suppliers, please provide this information to ASTM Headquarters. Your comments will receive careful consideration at a meeting of the responsible technical committee, which you may attend.

<sup>4</sup> PEG200 or Carbowax 200

<sup>4</sup> Methocel®-4000 cps, Type F4M available from Union Carbide Corp., Ethylene-Oxide/Glycol Div., Danbury, CT Dow Chemical Co., Midland, MI has been found suitable for this purpose.

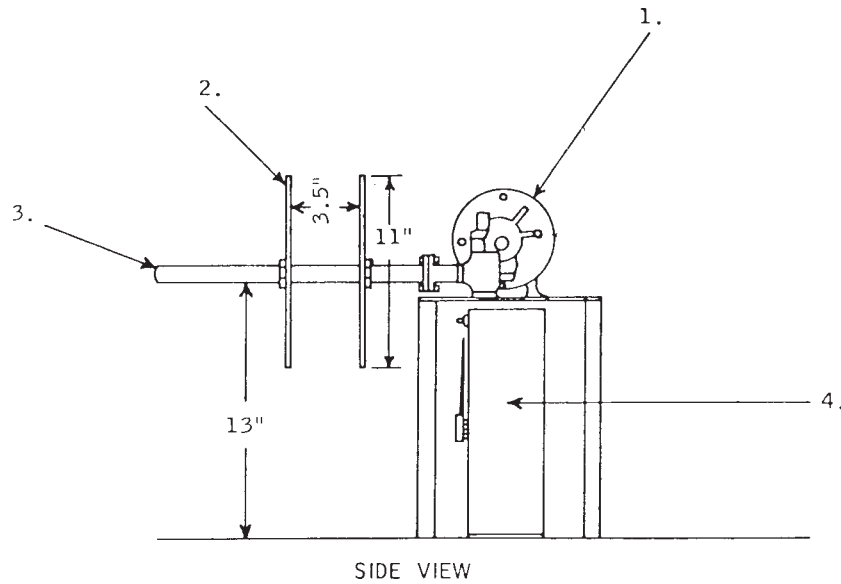

SIDE VIEW

1. Bodine speed reducer motor—Type NSE-11 RG, 21 r/min reducer output rating. Voltage to the motor is regulated using a variable voltage transformer ("Powerstat").
2. Lucite divider.
3. 1-in. diameter wood dowel.
4. Laboratory time ("Gra-Lab").

FIG. 2 Rota-rod Apparatus

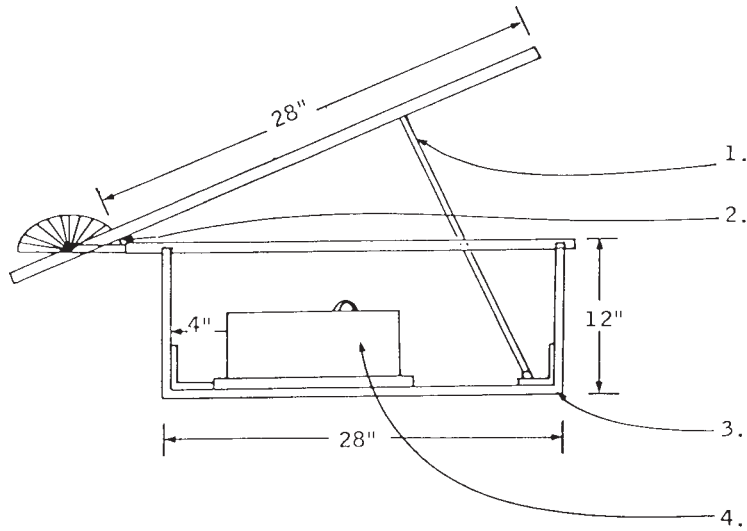

SIDE VIEW

1. Support rod.
2. Protractor.
3. End panels and base are 10 in. wide.
4. 12 by 9½ by 5-in. elliptical sheet metal enclosure for air blast box. The enclosure is centered across the base of the narrow strip apparatus; the air blast box is centered inside the elliptical enclosure.

FIG. 3 Narrow Strip Apparatus, Showing the Location of the Air-Blast Enclosure

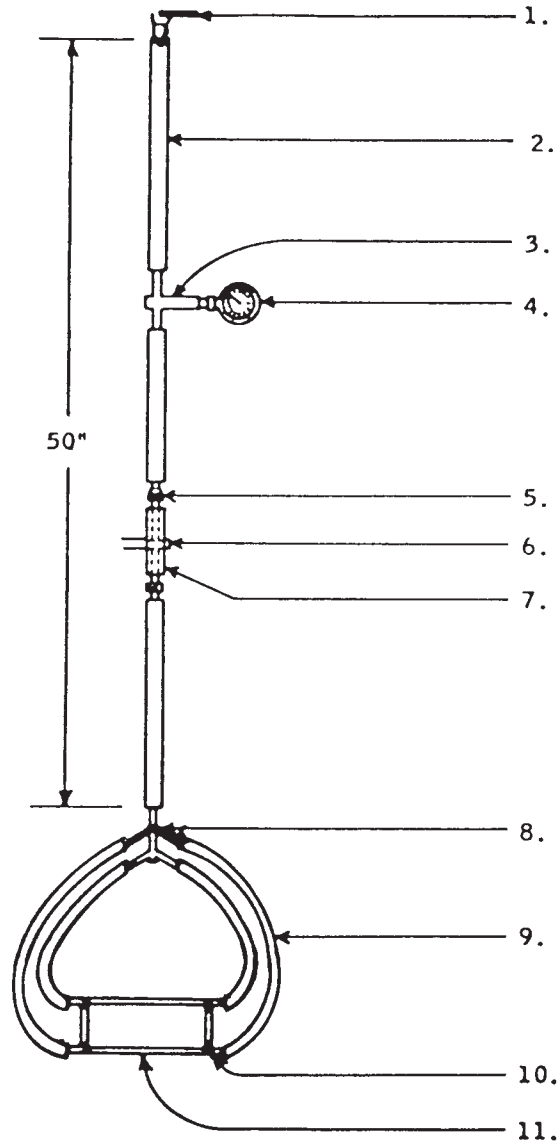

TOP VIEW

1. Compressed air supply.
2. Rubber pressure tubing,  $\frac{3}{16}$ -in. outside diameter,  $\frac{3}{16}$ -in. inside diameter.
3. Brass T tube,  $\frac{5}{32}$ -in. inside diameter. T arms.
4. Ashcroft pressure gage (0 to 60 psi) Manning, Maxwell and Moore, Inc. Stratford, CT.
5. Brass hosecock with  $\frac{1}{8}$ -in. diameter bore.
6. Rotating shaft ( $\frac{1}{8}$ -in. diameter hole) resting in steel bearing.
7. Steel bearing.
8. Side-armed steel tube,  $2\frac{1}{2}$  in. long, 2-in. side arms, and  $\frac{3}{16}$ -in. diameter bore.
9. Thirteen-inch long pieces of rubber tubing, 1-cm outside diameter, 0.5-cm inside diameter.
10. Lucite nipple cemented at right angles at the bottom of each corner. Each nipple is 1 in. long,  $\frac{3}{8}$ -in. outside diameter,  $\frac{1}{8}$ -in. inside diameter Lucite tubing.
11. Air blast box with internal dimensions  $4\frac{1}{2}$  in. (L) by  $2\frac{1}{2}$  in. (W) by  $1\frac{1}{2}$  in. (H), made of clear  $\frac{1}{4}$ -in. Lucite. The hole through the wall of the box at the bottom of each corner is  $\frac{1}{8}$  in. diameter and is aimed at the top of the diagonally opposite corner.

FIG. 4 Air Blast Apparatus

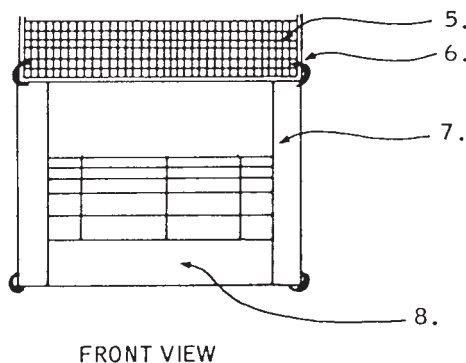
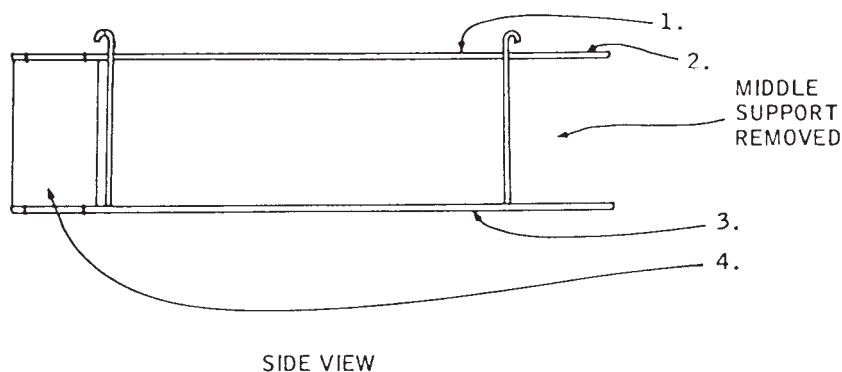

1. 1/4-in. mesh.
2. 3.5-mm cadmium plated frame.
3. 1-in. mesh.
4. Wooden block.
5. 1/4-in. mesh.
6. Nail or staple.
7. Wooden block.
8. 2 by 4-in. open section (wire mesh removed) where mice are tested.

**FIG. 5 Modified Test-Tube Rack (Horizontal Wire Apparatus)**

Solvent	Maximum Volume to Use
Distilled water	10 mL/kg
25 % aqueous solution PEG200 <sup>4</sup>	10 mL/kg
25 % aqueous solution PEG200 <sup>5,3</sup>	10 mL/kg
Undiluted PEG200	2 mL/kg
0.5 % aqueous methylcellulose	10 mL/kg
0.1 N Hydrochloric acid	10 mL/kg
0.1 N Sodium hydroxide	5 mL/kg
10 % aqueous acetone	5 mL/kg
10 % aqueous ethyl alcohol	5 mL/kg
0.5 % aqueous acetic acid	10 mL/kg
1 % aqueous lactic acid	10 mL/kg

## 6. Test Solutions

6.1 One-gram quantities of test materials are sufficient for both solubility testing and injection.

6.2 If mixtures or formulations are to be studied, up to 10-g quantities may be needed depending on the expected dilutions to be tested.

6.3 Test solutions are usually made in volumes of 10 mL. Liquid test materials are prepared as volume/volume (v/v) solutions, and solids are prepared as weight/volume (w/v) solutions.

6.4 Stock concentrations of 10 mg/mL (10 mm<sup>3</sup>/mL for liquids) shall be prepared initially. Serial dilutions are prepared from this stock solution as needed, keeping the number of dilutions to the minimum number required to allow total injection volumes

<sup>4</sup>The Galton Whistle is

<sup>5</sup>PEG200 or Carbowax 200 available from Sargent-Welch Scientific Co., 7300 North Linder Ave., Skokie, IL 60077; Union Carbide Corp., Ethylene Oxide/Glycol Div., 39 Old Ridgeberry Rd., Danbury, CT 06817-0001 has been found suitable for this purpose.

of 0.05 to 0.25 mL for aqueous solutions or suspensions. When undiluted PEG200 is required as the solvent, injected volumes must be restricted to 0.01 to 0.05 mL per mouse. Acetone, NaOH, and ethyl alcohol solutions can only be injected at volumes up to 0.125 mL.

## 7. Test Animals

7.1 Male ICR Swiss mice, weighing 18 to 25 g, are used for this test method. Although either sex may be used if desired, experience has shown that results are more reproducible if only males are employed.

7.2 The number of mice required for screening each compound will depend on the potency of the material being tested but, overall, approximately 30 mice are required.

7.3 Quarantine all animals for a period of at least one week before use to ensure their good health and to acclimate them to their quarters and diet. Allow animals continuous access to feed and water.

7.4 In experiments where female mice are used, pregnant or lactating animals shall be excluded.

## 8. Procedure

8.1 Conduct the experiment in two phases, one in which the animals are carefully observed without being disturbed (see 9.4), and a second that requires handling (see 9.5).

8.2 Because a complete evaluation of the treated mice may take as long as 5 min, depending on the signs elicited, the injection schedule is left flexible until a response pattern is established.

8.3 Observe the injected mice at 3, 15, 30, and 60 min after intravenous injection in a lateral tail vein and hourly thereafter throughout the workday.

8.4 Conduct a range-finding study first. For aqueous solutions, inject the first animal with the stock concentration at 10 mL/kg of body weight, with a resultant dose of 100 mg/kg. Frequently this dose will prove to be lethal, with death occurring in 1 to 2 min. Should that be the case, dose a second mouse at 3.16 mL/kg body weight (31.6 mg/kg).

8.5 Make a 1 + 9 dilution of the stock solution for the next two doses, which are spaced at 0.5-log intervals below the preceding one. Repeat this procedure until a mouse survives for 5 min.

8.6 At this point, test a second mouse at the apparent nonlethal dose. If both mice survive, test doses decreasing by 0.5-log intervals using 2 mice per dose until the no-effect level is reached. Test each animal's responses at the predetermined time intervals, so that the effect of intermediate doses is obtained in detail.

8.7 These data are sufficient to allow a decision to be made as to the desirability of further testing.

8.8 If further testing is indicated, obtain a more accurate estimate of the LD50 and MED50. Use the lethal and no-effect levels observed in the range-finding study as the points for additional dosage selection.

8.9 Test a total of 4 mice at each of four doses spaced 0.1-log apart for both the LD50 and MED50 determinations. Inject 2 or 3 additional mice at the apparent LD50 level, and 4 at each of the three next three lower levels for the observations in Section 9. Use a similar design for the MED50, except that the successive 0.1 log doses are above the apparent no effect level.

8.10 Include solvent injected control mice in these studies as needed. At least 2 control mice are required for comparison with test material treated mice. One should be injected first and the second 20 min later, since the animals tend to lose interest in their surroundings after that time and go to sleep. Additional controls should be added at 20-min increments.

## 9. Observations

9.1 Place a fresh sheet of paper on the floor of the observation platform (Fig. 1) before the experiment is begun. As each mouse is injected, place the animal in a numbered compartment of the platform.

9.2 At the highest doses, effects of the test material are usually immediately apparent, while delays of a minute or two before the onset of effects is the norm at lower levels.

9.3 Observe the reactions that can be assessed without touching the animal (nonmanipulative effects) first followed by those that require handling of the mice (manipulative effects).

### 9.4 *Nonmanipulative Effects:*

9.4.1 Make observations in a standard sequence as follows: tremors, convulsive reactions, prostration, and death; changes in locomotor activity and rearing; changes in respiration; changes in posture and gait; changes in somatic responses; all other generalized changes, for example, bizarre reactions, cyanosis, piloerection; then localized changes, for example, phonation, exophthalmos, straub tail.

9.4.2 Periodically during the testing period, note the volume and appearance of both feces and urine excreted by each mouse. Alterations in the normal excretory pattern may indicate important pharmacological effects.

### 9.5 *Manipulative Effects:*

9.5.1 Do not conduct the battery of manipulative tests when either convulsions or a subconvulsive state (resulting in convulsions when the animals are handled) exists. The additional stress produced by handling may be sufficiently severe to impede recovery, or even cause death in animals that would otherwise survive. Record the fact that manipulative tests were not conducted.

9.5.2 Observe the reaction of the mouse to repetitive light contact with the trunk using the tapered surface of a sharpened wooden pencil. An exaggerated response indicates sensitivity to touch. Next touch lightly the back of the neck with the point of the pencil. A repeatable vigorous head twitch is indicative of compound effect.

9.5.3 Observe the response upon being scooped up in the palm of the hand or picked up by the tail. At this time, evaluate the muscle tone as the animal moves about in the experimenter's palm.

9.5.4 Observe eye effects by placing the mouse on a wire mesh and lightly restraining it by holding its tail. Illuminate the surface of the eye from above, allowing pupillary or other eye effects to be noted.

9.5.5 Following the eye examination, touch the cornea with the tip of a horsehair bristle. Then touch the walls of the ear canal (not the eardrum) for the Pinnal reflex test. Lack of response in either test indicates a pharmacological effect.

9.5.6 Next test the labyrinthine reflex. Hold the mouse by its tail with its legs hanging free; a normal mouse will try to gain an upright posture by a vigorous attempt to climb its tail. Following this test, record other signs noted upon close inspection of the animal.

9.5.7 Test righting reflex by placing the mouse on its back on a tabletop; unaffected mice will immediately assume an upright position.

9.5.8 Place the mouse on a tabletop facing away from the edge while restraining it by the tail. Grasp the hind paw, pull it over the table edge, and release it. If the reaction is normal, the paw will immediately return to its natural position.

9.5.9 Conduct the last reflex test by holding the animal by its tail and slowly lowering it toward a tabletop. Normal mice extend their forelegs in anticipation of touching the surface before making actual contact.

9.5.10 Use a chemical laboratory ringstand with a 0.5-in. (1.27-cm) diameter rod for the next test. Place the mouse at the top of the stand facing down, and allow it to grasp the rod with all four feet. When the tail is curled around the rod, release the animal. Normal descent is accomplished by hindleg stepping movements, not sliding.

9.5.11 The next test requires a constant speed rotarod apparatus which can be homemade, such as that depicted in Fig. 2 or purchased from commercial producers. Place the mouse on the rod which is then activated to turn at a constant speed of 15 to 18 rpm and run for 1 min. A normal animal will remain on the top of the rod during the test.

9.5.12 Use the narrow strip apparatus shown schematically in Fig. 3 for the next two steps. First, place a mouse at the bottom of the inclined strip; release the animal. A normal subject will rapidly ascend the strip without difficulty. Next, place the mouse at the end of the horizontal strip, and stimulate the animal to traverse the strip with the sound of the pulsed air apparatus beneath it (see Fig. 4 and 9.5.13). If necessary for either test, the mouse is motivated to perform by gentle prodding.

9.5.13 The next test requires the airblast equipment shown in Fig. 4; operate it at 330 pulses/min and 10 to 30 psi. Hold the mouse by the tail just above the box and release. Normal mice immediately get out of the box.

9.5.14 The equipment used for this test is a wire test tube rack modified as shown in Fig. 5. Place the rack on a tabletop with the bar at the open end (between the wooden blocks) extending over the edge. Hold the mouse by the tail facing the table, and allow it to grasp the bar with its front paws. Then exert sufficient tension on the tail to stretch the mouse into a vertical position, and release. A normal mouse will rapidly draw himself up to perch on all four legs on the bar.

9.5.15 For the next test, the test tube rack is set on end so that the wire mesh is at right angle to the table. Start the mouse at the base of the rack and gently prod to motivate it to climb the screen.

9.5.16 Evaluate possible analgesic effect of test compound by clamping a 38-mm artery clamp (serrefine) at the base of the tail and immediately release the animal. Normal reaction is phonation and vigorous biting at the clamp.

9.5.17 At the completion of this series of tests, return the mouse to its cubicle and allow a short rest before the last manipulative test is performed.

9.5.18 This test measures the sensitivity to sound and is conducted using the Galton Whistle.<sup>6,3</sup> Set the whistle orifice at 2 mm. Hold it over the cubicle with the hole up, and squeeze the bulb several times. Normal mice will “freeze” with ears laid back and eyes tightly closed.

9.6 After completion of the manipulative tests on the two mice given the same dose of test compound, place them briefly in the same cubicle to observe their responses to one another. Use a solvent-treated control pair for comparison.

9.7 Test each mouse until two consecutive sign-free observation times are noted; the animal is considered to be normal at this point. Furthermore, in those cases where a variety of responses are noted, two sign-free observations for a given effect are sufficient to omit that test at subsequent scheduled observation times.

9.8 Remove mice that are considered normal from the observation platform and place in individual cages for overnight observation of delayed compound effects. Feed and water *ad libitum*. On the following morning retest each mouse to assure normalcy. Assuming that no effects are seen, consider the test to be complete.

9.9 House mice showing effects at the end of the experimental day and test again (see 9.8). Should effects persist, test the mouse daily until recovery is complete. The number of compounds that produce effects for more than 24 h is very small.

## 10. Quality Assurance

10.1 To ensure the quality and reliability of data developed using this test method, good laboratory practices should be followed (1, 2, 3).<sup>7</sup>

<sup>6</sup> The boldface numbers in parentheses refer to the list of references at the end of this standard. Galton Whistle is available from Sargent-Welch Scientific Co., 911 Commerce Court, Buffalo Grove, IL 60089.

<sup>7</sup> The boldface numbers in parentheses refer to the list of references at the end of this standard.

## 11. Data Recording

11.1 There are numerous possible means for recording and storing the data obtained from this test method. The only requirement placed on the procedure is that the data be clear and understandable (see Appendix X1).

11.2 The following conventions regulate the recording of data.

11.2.1 Report the earliest time to appearance of a sign and the latest time to recovery for each mouse measured from the time of injection.

11.2.2 Report only the maximum degree of effect observed for those responses that can be graded.

11.2.3 For those animals that die during the 24-h experimental period, report only “death”.

11.2.4 A reaction must occur for at least 3 min to be recorded. Those effects observed in solvent-treated control mice are not construed as effects induced in dosed animals.

11.3 A listing of the possible reaction signs that may occur is given in Table 1. The list is not exhaustive but covers the more commonly observed effects. Those effects that can be graded are indicated (see footnotes A, B, and C).

## 12. Statistical Evaluation of Results

12.1 Both the LD50 and MED50, with their 95 % confidence limits, are estimated using the Moving Average Method of Thompson and Weil (4). The statistical procedure requires that a constant log interval between doses be maintained.

**TABLE 1 Listing of Possible Mouse Reaction Signs in Order of Observation**

Nonmanipulative	Manipulative
1. Fasciculations	1. Increased or decreased sensitivity to touch <sup>A,B</sup>
2. Tremors-rest and movement <sup>A,B</sup>	2. Head twitching
3. Tremors-movement only <sup>A,B</sup>	3. Increased aggressiveness-handling
4. Subconvulsive movements	4. Increased or decreased muscle tone
5. Clonic convulsions	5. Flaccid paralysis
6. Tonic convulsions	6. Spastic paralysis
7. Mixed convulsions	7. Hemorrhage-injection site
8. Prostration	8. Erythema
9. Loss of consciousness	9. Ischemia
10. Death	10. Necrosis-injection site
11. Increased or decreased locomotor activity <sup>A,B</sup>	11. Vasoconstriction
12. Stereotyped locomotion	12. Vasodilation
13. Aimless wandering	13. Edema
14. Backward movements	14. Mydriasis <sup>A,C,B</sup>
15. “Shovelnose” movements	15. Miosis <sup>A,C,B</sup>
16. Circling movements	16. Pupillary light reflex depressed or absent
17. Jumping	17. Lacrimation <sup>A,B</sup>
18. Increased or decreased rearing frequency	18. Eye opacity
19. Increased or decreased speed of rearing	19. Conjunctivitis
20. Decreased rearing height	20. Iritis
21. Increased or decreased respiratory rate <sup>A,B</sup>	21. Eyelid ptosis <sup>A,B</sup>
22. Increased or decreased respiratory depth	22. Photophobia
23. Dyspnea <sup>A,B</sup>	23. Corneal reflex depressed or absent
24. Apnea <sup>A,B</sup>	24. Pinnal reflex depressed or absent
25. Postural change (specify)	25. Labyrinthine reflex depressed or absent
26. Abnormal gait (specify)	26. Nasal discharge
27. Ataxia <sup>A,B</sup>	27. Salivation <sup>A,B</sup>
28. Increased or decreased preening	28. Righting reflex depressed or absent
29. Increased or decreased scratching	29. Placing reflex depressed or absent
30. Rubbing nose	30. Position sense reflex absent
31. Writhing	31. Motor deficit—vertical rod <sup>A,B</sup>
32. Recurrent paw stamping	32. Motor deficit—rota-rod <sup>A,B</sup>
33. Catalepsy	33. Motor deficit—inclined strip <sup>A,B</sup>
34. Glassy-eyed stare	34. Motor deficit—horizontal strip <sup>A,B</sup>
35. Opisthotonus	35. Motor deficit—airblast <sup>A,B</sup>
36. Emprosthotonus	36. Motor deficit—horizontal wire <sup>A,B</sup>
37. Cyanosis	37. Motor deficit—vertical screen <sup>A,B</sup>
38. Piloerection	38. Increased or decreased sensitivity to pain <sup>A,B</sup>
39. Increased or decreased defecation	39. Analgesia
40. Diarrhea	40. Increased or decreased sensitivity to sound <sup>A,B</sup>
41. Bloody stools	41. Audiogenic seizures
42. Retching	42. Increased aggressiveness-mice
43. Increased or decreased urination	43. Nuzzling
44. Hematuria	44. Social interaction altered
45. Excessive blinking	
46. Exophthalmos	
47. Abnormal tail (specify)	
48. Phonation	
49. Licking compartment walls	

<sup>A</sup> Responses are graded as **slight**.

<sup>B</sup> Responses are graded as **marked**.

<sup>C</sup> Responses are graded as **moderate**.

12.2 Convenient tables for determining LD50 and MED50 values have been published (5, 6). While their use eliminates the need for computing the values, their use requires a constant number of animals be tested at each dosage level.

12.3 Even the slope values for the dose-response curves can be obtained using the method described by Weil (7), if that value is needed.

### 13. Report

13.1 The report shall include the following information:

13.1.1 SName of the investigator(s), laboratory, laboratory address, location of raw data, date and initiation and termination of test.

13.1.2 Description of the test facilities and housing conditions, including cages, humidity and temperature.

13.1.3 Detailed description of the test substance(s) including the chemical name, Chemical Abstract Services (CAS), number, synonyms, structure, purity, source batch, lot number, physical/chemical properties.

13.1.4 Strain and sex of mouse tested, number of animals per dose level, and weight range used.

13.1.25 Calculated LD50 and MED50 with their 95 % confidence limits. If desired, the calculated slope of the regression lines can also be shown.

13.1.36 The doses administered, the toxic signs observed at each dose level, the severity of the effect if it can be graded, and its onset and duration.

13.1.47 Detailed information as to how the test solutions were prepared including what solvent was used and any mechanical or physical adjuncts (for example, grinding in a mortar and pestle followed by heating to 60°C) used to aid dissolution.

13.2 Note any effects occurring during the test that were attributed to the solvent system and thus not included as a pharmacological effect.

13.3 Highlight any unusual or unexpected results that appear to warrant special emphasis in the report.

13.4 Sample data sheets for two different classes of compounds are shown in Figs. 7 and 8. As noted in 11.1, these could be prepared in even less detailed form. Conversely, the sheets could be expanded to show each nuance of change observed at the doses given. The degree of accuracy desired dictates the format to be followed.

### 14. Precision and Bias

14.1 A precision and bias statement cannot be made at this time.

### 15. Keywords

15.1 chemicals; ED50; LD50; manipulative tests; MED50; mice; nonmanipulative tests; pesticides; pharmacology; toxicity

APPENDIXES

(Nonmandatory Information)

X1. SAMPLE DATA SHEET FOR ETONITAZINE HYDROCHLORIDE

Name: Benzimidazole, 1(2-diethylaminoethyl)-2-(*p*-ethoxybenzyl)-5-nitro

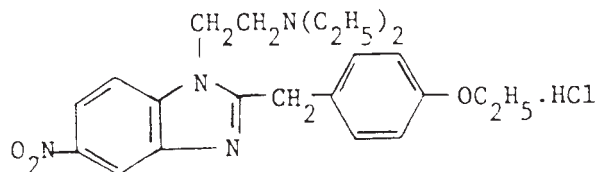

LD<sub>50</sub> = 70.6 (58.5–85.2) mg/kg  
 MED<sub>50</sub> = 4.5<sup>-5</sup>(3.8<sup>-5</sup>–5.3<sup>-5</sup>) mg/kg  
 RATIO = 15.7<sup>+5</sup>

State: Solid

INTRAVENOUS TOXICITY TO MICE

Dose, <sup>78</sup> mg/kg	Dilution, mL/kg	Reaction Fraction	Reactive Signs	Minutes to Appear	Degree	Minutes to Recover
100.0	10.0	4/4	Death	2		
80.0	8.0	2/4	Death	10		
			Decreased locomotor activity	3	3+	>30<210
			Increased locomotor activity	<210	+	>360<ON <sup>8</sup>
			Increased locomotor activity	<210	±	>360<ON <sup>9</sup>
			Stereotyped locomotion	<210		>360<ON
			Decreased rearing frequency	3		>24 h<48 h
			Decreased respiratory depth	3		>360<ON
			Hunched posture	3		>360<ON
			Spastic gait	<210		>360<ON
			Catalepsy	3		>360<ON
			Glassy-eyed stare	3	+	>360<ON
			Decreased defecation			>24 h<48 h
			Decreased urination			>24 h<48 h
			Exophthalmos	3		>360<ON
			Abnormal vibrissae	3		>360<ON
			Rigid tail	3		>360<ON
			Decreased sensitivity to touch	3		>360<ON
			Increased aggressiveness-handling	3	+	>360<ON
			Increased muscle tone-trunk	3		>360<ON
			Increased muscle tone-limbs	3		>360<ON
			Mydriasis	3	3+	>360<ON
			Pupillary light reflex absent	3		>360<ON
			Corneal reflex absent	3		>360<ON
			Pinnal reflex depressed	3		>360<ON
			Labyrinthine reflex absent	3		>360<ON
			Placing reflex absent	3		>360<ON
			Position sense reflex absent	3		>360<ON
			Motor deficit—all tests	3	3+	>24 h<48 h
			Analgesia	3		>360<ON
			Increased sensitivity to sound	<210	+	>360<ON
63.0	6.3	2/4	Death	4		
			Same nonlethal toxic signs as above <i>plus</i>			
			Eye opacity	<300		<20 h

Dose, <sup>A,B</sup> mg/kg	Dilution,mL/kg	Reaction Fraction	Reactive Signs	Minutes to Appear	Degree	Minutes to Recover
<b>ETONITAZINE HCl</b>						
32.0	3.2	2/2	Same signs as above			<27 h
10.0	10.0	2/2	Same signs as above			<27 h
0.10	10.0	2/2	Same signs as above			<17 h
0.032	3.2	1/2	Stereotyped locomotion	3		30
			Decreased rearing frequency	3		>90<16 h
			Decreased respiratory rate	3		>30<16 h
			Decreased respiratory depth	3		>30<16 h
			Hunched posture	3		>30<16 h
			Decreased preening	3		>30<16 h
			Spastic gait	3		>30<16 h
			Glassy-eyed stare	3		>30<16 h
			Exophthalmos	3		>30<16 h
			Rigid tail	3		>30<16 h
			Decreased sensitivity to touch	3	+	>30<16 h
			Mydriasis	3	+++	>30<16 h
			Motor deficit vertical rod	3	+++	>30<16 h
		1/2	Eye opacity	30		>30<16 h
			Motor deficit horizontal wire	3	+	>30<16 h
			Motor deficit rota-rod	3	+++	>30<16 h
3.2 <sup>-3</sup>	3.2	2/2	Decreased locomotor activity	3	+	60
			Decreased rearing frequency	3		60
			Glassy-eyed stare	3		60
			Exophthalmos	3		60
1.0 <sup>-3</sup>	10.0	2/2	Decreased locomotor activity	3	+	30
			Decreased rearing frequency	3		30
		1/2	Decreased sensitivity to touch	3		30
			Glassy-eyed stare	3		30
3.2 <sup>-4</sup>	3.2	2/2	Decreased locomotor activity	3	+	15
			Decreased rearing frequency	3		15
1.0 <sup>-4</sup>	10.0	2/2	Same signs as above	3		15
5.0 <sup>-5</sup>	5.0	3/4	Same signs as above	3		15
4.0 <sup>-5</sup>	4.0	1/4	Same signs as above	3		15
3.2 <sup>-5</sup>	3.2	4/4	No effect			
1.0 <sup>-5</sup>	10.0	2/2	No effect			

<sup>A</sup> Dilution made as follows: 27.20 mg of compound plus 2.69 mL of distilled water. Further dilutions made with distilled water.

<sup>B</sup> ON = Overnight.

X2. SAMPLE DATA SHEET FOR CHLORPROMAZINE

Name: 2-Chloro-10-(3-dimethylaminopropyl)phenothiazine

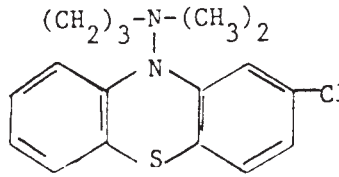

LD<sub>50</sub> = 28.3(23.4-34.1) mg/kg  
 MED<sub>50</sub> = 0.27(0.20-0.36) mg/kg  
 RATIO = 105

State: Solid

INTRAVENOUS TOXICITY TO MICE

Dose, <sup>910</sup> mg/kg	Dilution, mL/kg	Reaction Fraction	Reactive Signs	Minutes to Appear	Degree	Minutes to Recover
40.0	4.0	4/4	Death	1/2		
32.0	3.2	2/4	Death	2		
			Prostration	3		>160<ON <sup>A</sup>
			Increased respiratory depth	3		60
			Decreased respiratory depth	60		>160<ON
			Decreased respiratory rate	<160		>160<ON
			Decreased defecation			>160<ON
			Decreased urination			>160<ON
			Limp tail	3		>160<ON
			Decreased sensitivity to touch	3	+++	>160<ON
			Decreased muscle tone—trunk	3		>160<ON
			Decreased muscle tone—limbs	3		>160<ON
			Eyelid ptosis	3	+	>160<ON
			Corneal reflex depressed	3		>160<ON
			Pinnal reflex depressed	3		>160<ON
			Labyrinthine reflex absent	3		>160<ON
			Placing reflex absent	<160		>160<ON
			Righting reflex absent	<160		>160<ON
			Motor deficit—all tests	3	3+	>160<ON
			Decreased sensitivity to pain	3		>160<ON
			Decreased sensitivity to sound	3	3+	>160<ON
25.0	2.5	2/4	Death	1/2		>160<ON
			Same non-lethal toxic signs as above			
20.0	8.0	4/4	Same non-lethal toxic signs as above			>160<ON
10.0	10.0	4/4	Prostration	3		60
			Decreased locomotor activity	60	+	>420<ON
			Decreased rearing frequency	60		>420<ON
			Low posture	60		420
			Abnormal gait (limbs extended)	3		420
			Low carriage	60		420
			Decreased preening	60		420
			Decreased defecation			>420<ON
			Decreased urination			180
			Limp tail	3		<300
			Decreased sensitivity to touch	3	3+	>300<420
			Decreased muscle tone—trunk and limbs	3		>300<420
			Eyelid ptosis	3	+	>300<420
			Labyrinthine reflex absent	3		>300<420
			Placing reflex depressed	3		>300<420
			Motor deficit—all tests	3		<420

<sup>A</sup> ON = Overnight.

Dose, <sup>A,B</sup> mg/kg	Dilution, mL/kg	Reaction Fraction	Reactive Signs	Minutes to Appear	Degree	Minutes to Recover
<b>CHLORPROMAZINE</b>						
			Abnormal reaction to pain	3		<300
			Decreased sensitivity to sound	3	3+	>30<420
		3/4	Increased respiratory depth	3		<60
3.2	3.2	2/2	Prostration	3		60
			Same signs as above	60		120 (most)
1.0	10.0	4/4	Decreased locomotor activity	3	+	180
			Decreased rearing frequency	3		180
			Decreased defecation			180
			Decreased urination			120
			Eyelid ptosis	3	+	180
		3/4	Decreased preening	3		180
			Motor deficit—horizontal strip	3	+	>60<180
			Motor deficit—inclined strip	3	+	>60<180
			Social interaction altered			180
		2/4	Catalepsy	3		>60<180
			Decreased sensitivity to touch	3	+	>60<180
			Increased aggressiveness-handling	3		>60<180
			Motor deficit—vertical rod	3	+++	>60<180
			Motor deficit—airblast	15	+++	>60<180
		1/4	Low carriage	3		>60<180
			Abnormal gait (limbs extended)	3		>60<180
0.32	3.2	3/4	Eyelid ptosis	3	+	60
		2/4	Decreased locomotor activity	3	+	60
			Decreased rearing frequency	3		60
			Social interaction altered			180
0.25	10.0	1/4	Decreased locomotor activity	3	+	60
			Decreased rearing frequency	3		60
			Eyelid ptosis	3		60
			Social interaction altered			120
0.20	8.0	1/4	Same as above	3		30
0.158	6.3	4/4	No effect			
0.126	5.0	4/4	No effect			
0.10	10.0	4/4	No effect			

<sup>A</sup> Dilution made as follows: 21.1 mg of compound + 2.09 mL distilled water. Further dilutions made with distilled water.

<sup>B</sup> ON = Overnight.

## REFERENCES

- (1) Title 40, Code of Federal Regulations (CFR), Environmental Protection Agency, Subchapter E, Pesticide Programs; Part 160, Good Laboratory Practice Standards, 1 July 1986.
- (2) Title 21, CFR, Food and Drug Administration, Part 58, Laboratory Practice for Nonclinical Studies, 1987.
- (3) Title 40, CFR, Toxic Substance Control Act, Part 792, Good Laboratory Practice Standards, 1987.
- (4) Thompson, W. R., and Weil, C. S., "On the Construction of Tables for Moving-Average Interpolation," *Biometrics*, Vol 8, 1952, pp.51–54.
- (5) Weil, C. S., "Tables for Convenient Calculation of Median-Effective Dose (LD50 or ED50) and Instructions in Their Use," *Biometrics*, Vol 8, 1952, pp. 249–263.
- (6) Horn, H. J., "Simplified LD50 (or MED50) Calculations," *Biometrics*, Vol 12, 1956, pp. 311–322.
- (7) Weil, C. S., "Economical LD50 and Slope Determinations," *Drug and Chemical Toxicology*, Vol 6, 1983, pp. 595–603.

*ASTM International takes no position respecting the validity of any patent rights asserted in connection with any item mentioned in this standard. Users of this standard are expressly advised that determination of the validity of any such patent rights, and the risk of infringement of such rights, are entirely their own responsibility.*

*This standard is subject to revision at any time by the responsible technical committee and must be reviewed every five years and if not revised, either reapproved or withdrawn. Your comments are invited either for revision of this standard or for additional standards and should be addressed to ASTM International Headquarters. Your comments will receive careful consideration at a meeting of the responsible technical committee, which you may attend. If you feel that your comments have not received a fair hearing you should make your views known to the ASTM Committee on Standards, at the address shown below.*

*This standard is copyrighted by ASTM International, 100 Barr Harbor Drive, PO Box C700, West Conshohocken, PA 19428-2959, United States. Individual reprints (single or multiple copies) of this standard may be obtained by contacting ASTM at the above address or at 610-832-9585 (phone), 610-832-9555 (fax), or [service@astm.org](mailto:service@astm.org) (e-mail); or through the ASTM website ([www.astm.org](http://www.astm.org)).*