



Designation: C 1022 – 9302

# Standard Test Methods for Chemical and Atomic Absorption Analysis of Uranium-Ore Concentrate<sup>1</sup>

This standard is issued under the fixed designation C 1022; the number immediately following the designation indicates the year of original adoption or, in the case of revision, the year of last revision. A number in parentheses indicates the year of last reapproval. A superscript epsilon ( $\epsilon$ ) indicates an editorial change since the last revision or reapproval.

## 1. Scope

1.1 These test methods cover procedures for the chemical and atomic absorption analysis of uranium-ore concentrates to determine compliance with the requirements prescribed in Specification C 967.

1.2 The analytical procedures appear in the following order:

	Sections
<del>Uranium by Ferrous Sulfate Reduction—Potassium Dichromate</del>	<del>—</del>
<del>—Titrimetry</del>	<del>—9 to 16</del>
<u>Uranium by Ferrous Sulfate Reduction—Potassium Dichromate</u>	<u>—</u>
<u>—Titrimetry</u>	<u>9</u>
<del>Nitric Acid-Insoluble Uranium</del>	<del>17 to 25</del>
<u>Nitric Acid-Insoluble Uranium</u>	<u>10 to 18</u>
<del>Extractable Organic Material</del>	<del>26 to 33</del>
<u>Extractable Organic Material</u>	<u>19 to 26</u>
<del>Arsenic by Diethyldithiocarbamate (Photometric Method)</del>	<del>34 to 43</del>
<u>Arsenic by Diethyldithiocarbamate (Photometric Method)</u>	<u>27 to 36</u>
<del>Carbonate by CO<sub>2</sub> Gravimetry</del>	<del>44 to 50</del>
<u>Carbonate by CO<sub>2</sub> Gravimetry</u>	<u>37 to 43</u>
<del>Fluoride by Ion-Selective Electrode</del>	<del>51 to 58</del>
<u>Fluoride by Ion-Selective Electrode</u>	<u>44 to 51</u>
<del>Halides by Volhard Titration</del>	<del>59 to 66</del>
<u>Halides by Volhard Titration</u>	<u>52 to 59</u>
<del>Moisture by Loss of Weight at 110°C</del>	<del>67 to 73</del>
<u>Moisture by Loss of Weight at 110°C</u>	<u>60 to 66</u>
<del>Phosphorus by Spectrophotometry</del>	<del>74 to 82</del>
<u>Phosphorus by Spectrophotometry</u>	<u>67 to 75</u>
<del>Silicon by Gravimetry</del>	<del>83 to 89</del>
<u>Silicon by Gravimetry</u>	<u>76 to 82</u>
<del>Thorium by the Thorin (Photometric) Method</del>	<del>90 to 98</del>
<u>Thorium by the Thorin (Photometric) Method</u>	<u>83 to 91</u>
<del>Calcium, Iron, Magnesium, Molybdenum, Titanium, and Vanadium by Atomic Absorption Spectrophotometry</del>	<del>—</del>
<u>Calcium, Iron, Magnesium, Molybdenum, Titanium, and Vanadium by Atomic Absorption Spectrophotometry</u>	<u>99 to 108</u>
<del>Potassium and Sodium by Atomic Absorption Spectrophotometry</del>	<del>—</del>
<u>Potassium and Sodium by Atomic Absorption Spectrophotometry</u>	<u>102 to 111</u>
<del>Boron by Spectrophotometry</del>	<del>119 to 128</del>
<u>Boron by Spectrophotometry</u>	<u>112 to 121</u>

1.3 *This standard does not purport to address all of the safety concerns, if any, associated with its use. It is the responsibility of the user of this standard to establish appropriate safety and health practices and determine the applicability of regulatory limitations prior to use.* Specific precautionary statements are given in Sections 7, ~~39~~, 32, and Note ~~16~~, 14.

## 2. Referenced Documents

2.1 *ASTM Standards:*

<sup>1</sup> These test methods are under the jurisdiction of ASTM Committee C-26 on Nuclear Fuel Cycle and are the direct responsibility of Subcommittee C26.05 on Methods of Test.

Current edition approved Nov. 15, 1993; Jan. 10, 2002. Published February 1994; April 2002. Originally published as C 1022 – 84. Last previous edition C 1022 – 84 (1990); C 1022 – 93.

C 761 Test Methods for Chemical, Mass Spectrometric, Spectrochemical, Nuclear, and Radiochemical Analysis of Uranium Hexafluoride<sup>2</sup>

C 859 Terminology Relating to Nuclear Materials<sup>2</sup>

C 967 Specification for Uranium Ore Concentrate<sup>2</sup>

C 1254 Test Method for Uranium in Mineral Acids by X-Ray Fluorescence

C 1267 Test Method for Uranium by Iron (II) Reduction in Phosphoric Acid Followed by Chromium (IV) Titration in the Presence of Vanadium<sup>2</sup>

C 1347 Practice for Preparation and Dissolution of Uranium Materials for Analysis<sup>2</sup>

D 1193 Specification for Reagent Water<sup>3</sup>

E 60 Practice for Photometric and Spectrophotometric Methods for Chemical Analysis of Metals<sup>4</sup>

### 3. Terminology

3.1 *Definitions*—For definitions of terms used in these test methods, refer to Terminology C 859.

### 4. Significance and Use

4.1 The test methods in this standard are designed to show whether a given material meets the specifications prescribed in Specification C 967.

4.2 Because of the variability of matrices of uranium-ore concentrate and the lack of suitable reference or calibration materials, the precision and bias of these test methods should be established by each individual laboratory that will use them. The precision and bias statements given for each test method are those reported by various laboratories and can be used as a guideline.

4.3 Instrumental test methods such as X-ray fluorescence and emission spectroscopy can be used for the determination of some impurities where such equipment is available.

### 5. Interferences

5.1 Interferences are identified in the individual test methods.

5.2 Ore concentrates are of a very variable nature; therefore, all interferences are very difficult to predict. The individual user should verify the applicability of each procedure for specific ore concentrates.

### 6. Reagents

6.1 *Purity of Reagents*—Reagent grade chemicals shall be used in all tests. Unless otherwise indicated, it is intended that all reagents shall conform to the specifications of the Committee on Analytical Reagents of the American Chemical Society, where such specifications are available.<sup>5</sup> Other grades may be used, provided it is first ascertained that the reagent is of sufficiently high purity to permit its use without lessening the accuracy of the determination.

6.2 *Purity of Water*—Unless otherwise indicated, references to water shall be understood to mean reagent water conforming to Specification D 1193.

### 7. Precautions

7.1 Proper precautions should be taken to prevent inhalation or ingestion of uranium during sample preparation and any subsequent sample analysis.

### 8. Sampling

8.1 Collect samples in accordance with Specification C 967.

8.2 Special requirements for subsampling are given in the individual test methods.

## URANIUM BY FERROUS SULFATE REDUCTION—POTASSIUM DICHROMATE TITRIMETRY

### 9. Scope

9.1 This test method covers the determination of uranium in uranium-ore concentrates.

### 10. Summary of Test Method

~~10.1 A sample for analysis is taken according to a time-weighting procedure and dissolved concentrates. This test method was discontinued in a mixture of nitric January 2002 and sulfuric acids. Weighed solution aliquots are then taken for analysis.~~

<sup>2</sup> Annual Book of ASTM Standards, Vol 12.01.

<sup>3</sup> Annual Book of ASTM Standards, Vol 11.01.

<sup>4</sup> Annual Book of ASTM Standards, Vol 03.05.

<sup>5</sup> Reagent Chemicals, American Chemical Society Specifications, American Chemical Society, Washington, DC. For suggestions on the testing of reagents not listed by the American Chemical Society, see *Analar Standards for Laboratory Chemicals*, BDH Ltd., Poole, Dorset, U.K., and the *United States Pharmacopeia and National Formulary*, U.S. Pharmaceutical Convention, Inc. (USPC), Rockville, MD.

10.2 An excess of ferrous sulfate is used to reduce uranium(VI) to uranium(IV) in a concentrated phosphoric acid solution containing sulfamic acid. The excess iron is subsequently oxidized by nitric acid in the presence of molybdenum(VI). After dilution with water and addition replaced with Test Method C 1267.

9.2 The uranium content of vanadium(IV); the determination is completed by titrating with standard potassium dichromate solution to a potentiometric end point (1, 2, 3).<sup>6</sup>

## 11. Interferences

11.1 Interference sample may also be caused by silver, tin(II), arsenic(III), mercury, antimony(III), vanadium, manganese, molybdenum in the presence of nitric acid, platinum, palladium, osmium, iridium, ruthenium, and halides other than complexed fluorides (1, 3, 4, 5).

## 12. Apparatus

12.1 *Buret*, Class A, 50 mL or 100 mL, with a bulb reservoir.

12.2 *pH Meter*, with a platinum wire electrode and a calomel reference electrode.

12.3 *Magnetic Stirrer*.

12.4 *Timer*.

12.5 *Steam Bath*.

## 13. Reagents

13.1 *Hydrofluoric Acid* (HF, 48 %).

13.2 *Nitric Acid* (HNO<sub>3</sub>, sp gr 1.42)

13.3 *Perchloric Acid* (HClO<sub>4</sub>, 62 %)

13.4 *Sulfuric Acid* (9 M)—Add 500 mL H<sub>2</sub>SO<sub>4</sub> (sp gr 1.84) to 500 mL or iced water with constant stirring. Cool and dilute to 1 L with water.

13.5 *Ferrous Sulfate Solution* (1.0 M)—Add 100 mL of sulfuric acid (H<sub>2</sub>SO<sub>4</sub>, sp gr 1.84) to 750 mL of water as the solution is stirred. Add 278 g of FeSO<sub>4</sub>·7H<sub>2</sub>O and dilute the solution to 1 L with water. Discard after 2 weeks.

13.6 *Nitric Acid* (8 M) *Sulfamic Acid* (0.15 M) - *Ammonium Molybdate* (4 g/L) *Solution*—Dissolve 4 g of (NH<sub>4</sub>)<sub>6</sub>Mo<sub>7</sub>O<sub>24</sub>·4H<sub>2</sub>O in 400 mL of water, and add 500 mL of HNO<sub>3</sub> (sp gr 1.42). Mix, then add 100 mL of 1.5 M sulfamic acid solution (13.10), and mix.

13.7 *Phosphoric Acid* (H<sub>3</sub>PO<sub>4</sub>, 85 %).

13.8 *Potassium Dichromate* (20 g/L)—Dissolve 2 g of K<sub>2</sub>Cr<sub>2</sub>O<sub>7</sub> in 100 mL of water.

13.9 *Potassium Dichromate Solution, Standard* (0.02500 N)—Dissolve 1.2258 g of potassium dichromate<sup>7</sup> (K<sub>2</sub>Cr<sub>2</sub>O<sub>7</sub>) that has been dried for 1 h at 100°C in water, then dilute to 1 L with water in a volumetric flask. Mix thoroughly and record the temperature of the solution.

13.10 *Sulfamic Acid Solution* (1.5 M)—Dissolve 146 g of NH<sub>2</sub>SO<sub>3</sub>H in water and dilute to 1 L with water, then filter.

13.11 *Vanadyl Sulfate* (VOSO<sub>4</sub>·2H<sub>2</sub>O) *Crystals*—A highpurity reagent free of V<sup>3+</sup> and V<sup>5+</sup>, Vanadium<sup>+3</sup>, and Vanadium<sup>+5</sup> shall be used.

## 14. Procedure

14.1 Break the seal on the sample container (if packaged under vacuum) and mix contents for 5 to 10 min in a mixer.

14.2 Open the container, record the time of opening, and weigh accurately about 3 g of sample into a weighing dish.

14.3 Record the sample weight to the nearest 0.1 mg and the length of time taken to complete the sampling-weighing process; then wait this length of time and reweigh the sample.

14.4 Transfer the sample to a 400-mL beaker and wet it with water.

14.5 Add 15 mL HNO<sub>3</sub>, 20 mL 9 M H<sub>2</sub>SO<sub>4</sub>, and 3 mL of HClO<sub>4</sub> (62 %). Cover the beaker and take to fumes on a hot plate until the sample is dissolved.

14.6 Allow to cool, add 2 mL HF and heat to fuming.

14.7 Cool and transfer the solution, determined using a small amount of water, to a 125-mL plastic bottle tared to the nearest 1 mg. Dilute to about 100 mL with water.

14.8 Weigh the bottle Test Method C 1254. The user's laboratory must establish and contents to the nearest 1 mg and mix contents thoroughly.

14.9 Transfer a portion (weighed to the nearest 0.1 mg) of the sample solution containing 100 to 150 mg of uranium to a 400-mL beaker.

<sup>6</sup>The boldface numbers in parentheses refer to the list of references at the end of these test methods.

<sup>6</sup> Whatman brand No. 40 or its equivalent has been found suitable.

<sup>7</sup> NBS SRM 136e or its equivalent

<sup>7</sup> Whatman brand size 33 by 94 mm has been found suitable.

14.10 Rinse down the sides of the beaker with about 10 mL of water and place a magnetic stirring bar in the solution. document method performance.

NOTE 1—The volume 1—Dissolution of the final solution must not exceed 15 mL.

14.11 Add the following reagents in the order given, mixing after each addition: 5 mL of 1.5 M sulfamic acid solution, 40 mL of H<sub>3</sub>PO<sub>4</sub> containing 2 drops of 20 g/L K<sub>2</sub>Cr<sub>2</sub>O<sub>7</sub> solution, and 5 mL of 1.0 M FeSO<sub>4</sub> solution.

NOTE 2—Carefully pipet the FeSO<sub>4</sub> solution addition directly into the phosphoric acid-sulfamic acid solution.

14.12 Wait a minimum of 60 s, adjust the temperature of the solution to 35 to 40°C, then UOC samples may be achieved using the reagent to wash down the inner walls techniques or combination of the beaker, pipet 10 mL of the reagent prescribed techniques described in 13.6.

14.13 Stir for 2.5 min and let stand for an additional 0.5 min to allow bubbles to disperse.

NOTE 3—Because this reaction is time and temperature dependent, carefully observe C 1347 The laboratory must validate the times specified.

14.14 Add 100 mL performance of water and approximately 100 mg of VOSO<sub>4</sub>·2H<sub>2</sub>O roughly measured with a small spatula.

14.15 Start stirring rapidly, then insert the platinum and calomel electrodes. Titrate rapidly with 0.02500 N K<sub>2</sub>Cr<sub>2</sub>O<sub>7</sub> solution until a potential of 500 mV is reached. Then titrate more slowly to a sharp break in potential that will occur near 590 mV, allowing no more than 7 min before completion of the titration.

14.16 Record the volume of titrant to the nearest 0.01 mL and the solution temperature.

## 15. Calculation

15.1 Calculate the percentage of uranium content, *U*, on a sample basis as follows:

$$U = \frac{(T \times V) W_S \times 100}{W_F \times W_A} \quad (1)$$

where:

*F* = uranium equivalent to 1 mL of titrant, g,

*V* = volume of titrant, corrected C 1347 using characterized UOC samples. If C 1347 methods are not suitable for the differences between the temperature recorded in 14.16 and the temperature recorded in 13.9,

*W<sub>S</sub>* = weight of total UOC sample solution (see 15.1.1),

*W<sub>F</sub>* = weight of solid sample (see 15.1.2), and

*W<sub>A</sub>* = weight of sample aliquot taken for analysis (see 14.9), g.

15.1.1 Calculate dissolution, the weight of the total sample solution, *W<sub>S</sub>*, as follows:

$$W_S = W_4 - W_3 \quad (2)$$

where:

*W<sub>4</sub>* = weight of sample solution plus the container (see 14.8), g, and

*W<sub>3</sub>* = weight of container alone (see 14.7), g.

15.1.2 Calculate the weight of solid sample, *W<sub>F</sub>*, as follows:

$$W_F = W_1 - (W_2 - W_1) \quad (3)$$

where:

*W<sub>1</sub>* = initial weight of sample, g, and

*W<sub>2</sub>* = final weight of sample (see 14.3), g.

## 16. Precision and Bias

16.1 *Precision*—A relative standard deviation of 0.08 % has been reported (see 4.2).

16.2 *Bias*—For information on the bias of this test method see 4.2 and Refs (1-5). user may establish and document applicable dissolution methods.

## NITRIC ACID-INSOLUBLE URANIUM

### 170. Scope

170.1 This test method covers the determination of that quantity of uranium in uranium-ore concentrate that is not soluble in nitric acid.

### 181. Summary of Test Method

181.1 A sample of ore concentrate is digested in 10 M nitric acid at 95 to 100°C for 1 h. The slurry is filtered and the residue washed with 1 M nitric acid until the filtrate gives a negative test for uranium. The washed residue is then dried and ignited at 1000 ± 25°C for 1 h. The uranium content is determined on the ignited residue by spectrophotometry.

## **192. Interference**

192.1 At the specification limit for nitric acid insoluble uranium usually established for uranium-ore concentrates, interference effects are insignificant.

~~20.~~

## **13. Apparatus**

~~20.1~~

13.1 *Digestion Flask*, 500-mL, with side entry tube and attached reservoir.

~~20.2~~

13.2 *Stirring Apparatus*, with sleeve-type stirrer.

~~20.3~~

13.3 *Heating Mantle*, 250-W, controlled by a variable transformer.

~~20.4~~

13.4 *Büchner Funnel*.

~~20.5~~

13.5 *Porcelain Crucibles*, 40-mL.

~~20.6~~

13.6 *Muffle Furnace*.

~~20.7~~

13.7 *Filter Paper*, <sup>8</sup> of medium porosity.

~~20.8~~

13.8 *Spectrophotometer*, with 1-cm cells that are in accordance with Practice E 60.

## **214. Reagents**

214.1 *Nitric Acid (10 M)*—Dilute 62.5 mL of HNO<sub>3</sub> (sp gr 1.42) to 100 mL with distilled water.

214.2 *Nitric Acid (1 M)*—Dilute 62.5 mL of HNO<sub>3</sub> (sp gr 1.42) to 1 L with distilled water.

214.3 *Sodium Hydroxide (100 g/L)*—Dissolve 10 g of NaOH in 100 mL of water.

214.4 *Hydrogen Peroxide (H<sub>2</sub>O<sub>2</sub>, 30 %)*.

214.5 *Hydrochloric Acid (HCl, sp gr 1.19)*.

214.6 *Hydrofluoric Acid (HF, 48 %)*.

214.7 *Sulfuric Acid (9 M)*—Add 500 mL H<sub>2</sub>SO<sub>4</sub> (sp gr 1.84) to 500 mL of iced water with constant stirring. Cool and dilute to 1 L with water.

~~22.~~

## **15. Procedure**

2215.1 Weigh a 50.0 ± 0.1-g sample directly into the digestion flask.

2215.2 Place the flask in the heating mantle and adjust the support ring so that the joints of the flask and sleeve stirrer are engaged, and the stirrer blades turn freely but just clear the bottom of the flask.

2215.3 Transfer 95 mL of 10 M nitric acid to a 250-mL beaker and heat between 95 to 100°C.

2215.4 Slowly transfer the heated nitric acid solution to the digestion flask through the entry side tube with the stirrer turning.

NOTE 42—The stirrer is started before the acid is added to prevent material from sticking to the flask.

2215.5 Align a thermometer in such a manner that the mercury chamber of the thermometer is immersed in the stirring slurry, but adequately clears the turning stirrer blades.

2215.6 Quickly bring the sample to 97°C and digest between 95 to 100°C for 1 h while stirring. (Measure the 1-h digestion time after the temperature of the slurry has reached 97°C.)

2215.7 Turn off the variable transformer, but allow the stirrer to continue turning.

2215.8 Remove the thermometer and carefully rinse with water all slurry that adheres to it.

2215.9 Wipe the immersed portion of the thermometer with one fourth of a circle of filter paper and transfer the paper to a prepared Büchner funnel fitted with a filter paper.

~~22.10~~

15.10 Add 10 mL of paper pulp to the slurry and continue stirring for about 5 min.

2215.11 Turn off the stirrer, then lower the flask and mantle.

~~22.12~~

15.12 Carefully wash the slurry that adheres to the stirrer shaft and blades into the flask with water.

2215.13 Wipe the shaft and blades with one fourth of a circle of filter paper and transfer the filter paper to the Büchner funnel.

2215.14 Filter the slurry through the Büchner funnel and wash contents of the flask into the funnel.

~~2215.15~~ Wash the residue with 1 M nitric acid until a 10-mL portion of the filtrate shows no detectable yellow color when made basic with sodium hydroxide and after a few drops of H<sub>2</sub>O<sub>2</sub> (30 %) have been added as a color developer.

~~2215.16~~ Wash the residue several times with water after a negative test is obtained.

~~2215.17~~ Draw air through the filter until the residue and filter pad are dry.

~~2215.18~~ Scrape the residue and paper into a preignited (1000°C) tared 40-mL crucible, place on a hot plate and slowly char off the organic material.

~~2215.19~~ Ignite the residue for 1 h at 1000°C in a muffle furnace.

~~2215.20~~ Cool the crucible in a desiccator and weigh.

~~2215.21~~ Calculate the percentage of solids in accordance with ~~24.1.17.1~~.

NOTE 53—If the percentage of solids (insoluble residue) is greater than 0.1 %, grind and mix the residue and determine the total milligrams of uranium in the residue by the photometric procedure in ~~23.1-23.10~~.

**~~23.- 16.1-16.10.~~**

**16. Photometric Procedure for Uranium**

~~2316.1~~ Transfer the ground, blended residue from ~~22.20~~ 15.20 to a 100-mL beaker.

~~2316.2~~ Add 10 mL of water and 10 mL of HCl (sp gr 1.19), cover, and boil for 10 min.

~~2316.3~~ Add 5 mL of HNO<sub>3</sub> (sp gr 1.42) and boil until fuming of NO<sub>2</sub> ceases. Remove cover glass.

~~2316.4~~ Add 5 mL of 9M H<sub>2</sub>SO<sub>4</sub> and 2 mL of HF (48 %), then heat to dryness on the hotplate. Bake to fume off remaining H<sub>2</sub>SO<sub>4</sub> and cool.

~~2316.5~~ Wash down sides of beaker with water and add 5 mL of HNO<sub>3</sub>.

~~2316.6~~ Cover with a watchglass and digest for approximately 10 min near the boiling point.

~~2316.7~~ Quantitatively transfer the solution to a 250-mL volumetric flask. Add 25 mL of NaOH solution and a few drops of H<sub>2</sub>O<sub>2</sub>. Make up to mark with water and mix.

NOTE 64—The solution must be basic for yellow sodium peruranate color to develop.

~~2316.8~~ Measure the absorbance of the solution in a spectrophotometer at 425 nm in a 1-cm cell using a blank as reference. The blank is prepared by diluting 25 mL of NaOH, plus a few drops of H<sub>2</sub>O<sub>2</sub>, to 250 mL with water.

~~2316.9~~ Prepare a calibration curve covering the range from 0 to 50 mg of uranium from aliquots of a standard uranium solution. Proceed as in ~~23.5-23.8~~; 16.5-16.8. Plot the milligrams of uranium against absorbance readings.

~~2316.10~~ Determine the total milligrams of uranium in the sample solution from the calibration curve.

NOTE 75—If the sample solution falls outside the calibration range, dilute a portion with the reference-blank solution and read again.

**~~24.-~~**

**17. Calculation**

~~2417.1~~ Calculate the percentage of insoluble residue, *R*, present as follows:

$$R = \frac{R_w \times 100}{S_w} \tag{4}$$

$$R = \frac{R_w \times 100}{S_w} \tag{1}$$

where:

*R<sub>w</sub>* = weight of residue (see ~~22.20~~; 15.20), g, and

*S<sub>w</sub>* = weight of samples, g.

~~2417.2~~ If the insoluble residue exceeds 0.1 %, calculate the percentage of nitric acid-insoluble uranium, *U<sub>N</sub>*, and present as follows:

$$U_N = \frac{U}{S_w \times 10} \tag{5}$$

$$U_N = \frac{U}{S_w \times 10} \tag{2}$$

where:

*U* = uranium content calculated in ~~23.10~~; 16.10, mg, and

*S<sub>w</sub>* = weight of sample, g.

~~2417.3~~ Calculate the percentage of nitric acid-insoluble uranium, *U<sub>u</sub>*, on a uranium basis as follows:

$$U_u = \frac{U_N \times 100}{U_s} \tag{3}$$

where:

$U_N$  = nitric acid-insoluble residue present (see ~~24.2~~, 17.2), %, and

$U_s$  = uranium in sample, %.

~~25.~~

## **18. Precision and Bias**

~~25.1~~

18.1 Precision—A relative standard deviation for this test method has been reported as 10 % at the 0.2 % HNO<sub>3</sub> insoluble uranium level (see 4.2).

~~25.2~~

18.2 Bias—For information on the bias of this test method see 4.2.

## **EXTRACTABLE ORGANIC MATERIAL**

~~26.~~

## **19. Scope**

2619.1 This test method is used to determine the extractable organic material in uranium-ore concentrates. It is recognized that certain water-soluble organic materials, such as flocculating agents, are not measured by this test method.

## **270. Summary of Test Method**

270.1 This test method consists of a dual extraction using trichlorofluoromethane on the solid uranium-ore concentrate sample and chloroform on a subsequent nitric acid solution of the sample. Each of the extractants is evaporated to measure the amount of organic material extracted.

## **281. Interferences**

281.1 At the specification limit for extractable organic material established for uranium-ore concentrations, and within the scope of this test method, interferences are insignificant.

## **292. Apparatus**

292.1 Soxhlet Extraction Apparatus—The trichlorofluoromethane extraction is done in a Soxhlet extraction apparatus. Construct as follows (see Fig. 1):

292.1.1 Modify a medium Soxhlet extraction tube so that the sidearm siphon is about 2 cm high, therefore, reducing the volume of solvent needed. Insert a 3 to 4-cm long, 25-mm outside diameter glass tube upright into the extraction tube in such a manner that an extraction thimble may be placed on it.

292.1.2 Connect a 250-mL Florence flask, that has a 24/40 ground-glass joint on the lower end to the top of the extraction tube. A 250-mL heating mantle connected to a 7.5-A variable transformer shall be used to heat this.

292.1.3 Connect a Friedrichs condenser, that has a 45/50 ground-glass joint on the lower end, to the top of the extraction tube. Turn this side of the condenser upward, and fuse the outer member of a 24/40 ground-glass joint to it.

292.1.4 Connect a Graham condenser, that has a 24/40 ground-glass joint on the lower end, to the modified sidearm of the Friedrichs condenser. Unless the relative humidity is low, insulate the Graham condenser to prevent the condensation of water on the outside surface that might seep through the joint to the Friedrichs condenser. Foam insulation 1 cm thick may be used for this purpose. The Graham condenser is cooled with cold water from a water bath cooler, and may be required when trichlorofluoromethane is used for the extraction.

292.2 Heat gun (hot-air electric dryer), may be used to evaporate the solvent in procedure ~~31.6~~ 24.6 or ~~31~~ 24.15.

292.3 Extraction Thimbles.

292.4 Filter Paper.

~~29.5~~<sup>7</sup>

22.5 Phase Separator Paper.

~~30.~~<sup>9</sup>

## **23. Reagents**

230.1 Trichlorofluoromethane (or 1,1,2 trichlorotrifluoroethane)—Whenever a new supply is used, it should be checked for nonvolatile residue. Evaporate 100.0 mL just to dryness in a weighted platinum dish, cool to room temperature, and reweigh the dish. If there is any residue, either make the appropriate blank correction or distill the solvent before use to remove the nonvolatile impurities.

<sup>9</sup> Whatman brand No. 40 or its equivalent IPS has been found suitable.

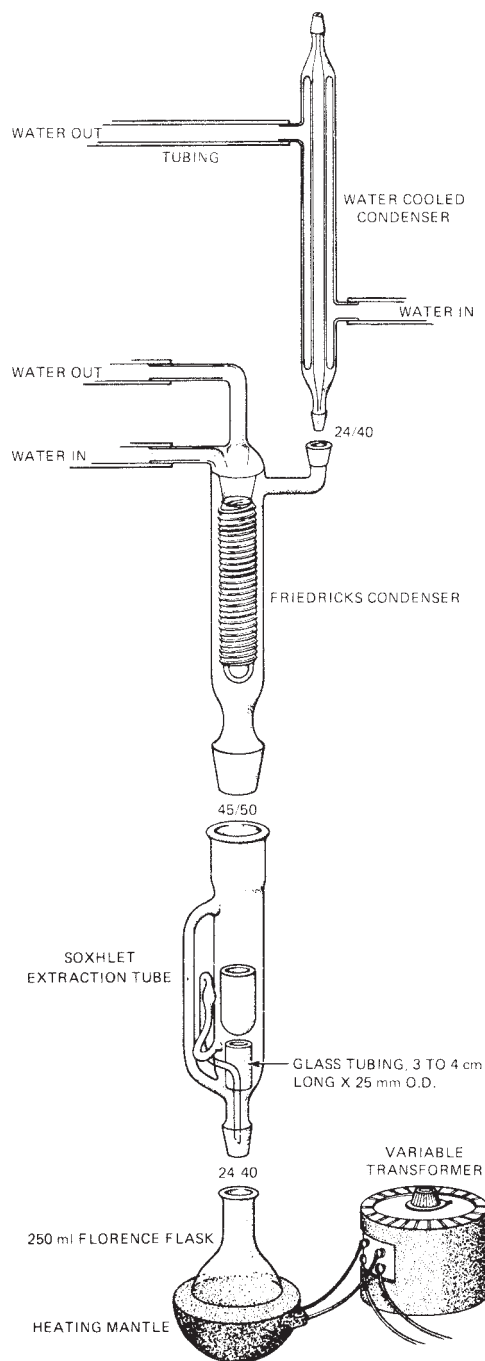

FIG. 1 Freon Extraction Unit

230.2 Nitric Acid (1 + 1)—Mix equal volumes of concentrated (sp gr 1.42) reagent grade HNO<sub>3</sub> and distilled water.

230.3 Chloroform—Whenever a new supply of chloroform is to be used, it should be checked for nonvolatile residue as described in 30.1.

**31- 23.1.**

**24. Procedure**

3124.1 Weigh 50.0 g of well-mixed, undried uranium-concentrate sample and transfer to an extraction thimble while tapping the thimble on a table top to compact and level the sample.

3124.2 Place a plug of glass wool in the thimble above the sample. Support the thimble on the glass tube in the Soxhlet extraction tube so that when solvent condenses on the lower tip of the Friedrichs condenser, it will drop into the thimble.

31.24.3 Connect the extraction tube to the bottom of the Friedrichs condenser that is in series with the Graham condenser. Turn on the tap water coolant to the condensers.

NOTE 86—Tap water may be used in cooling both condensers if the amount of reagent lost during the refluxing (see 31.5 24.5) is not greater than 10 % of the volume added in 31.4, 24.4. If the tap water is too warm, then the Graham condenser must be cooled by the refrigerated water cooler, or an ice-cooled condenser may be used in place of the Graham condenser.

31.24.4 Add a piece of sintered glass or several glass boiling beads and then 120 to 125 mL trichlorofluoromethane to the 250-mL Florence flask. Attach the flask to the Soxhlet extraction tube.

NOTE 97—If the humidity is high and results for extractable organic material on recent lots from the same producer have been less than 0.05 %, 1,1,2 trichlorofluoroethane may be used in place of trichlorofluoromethane to reduce any difficulty caused by the condensation of moisture.

31.24.5 Place the heating mantle below the Florence flask, connect to the variable transformer set at 55 to 60 V, and allow the reagent to reflux rapidly for 3 ½ to 4 h.

31.24.6 Pour the refluxed reagent into a weighed ( $W_1$  in grams) platinum dish, and evaporate in a hood. An infrared lamp or hot air stream from a heat gun may be used.

NOTE 108—Exercise care in this evaporation. If a heat source is used, adjust the rate of heat input and velocity of air across the dish so that no sample will be mechanically lost. If a heat gun is used, the amount and temperature of the air directed against the sample are especially critical because the high rate of evaporation is likely to lower the temperature of the solution to the point where water will condense in the dish.

31.24.7 Allow the dish to come to room temperature while tilting and rotating it to spread the last few drops of solvent uniformly over the bottom.

NOTE 11—Do 9—Do not allow the temperature of the dish to go below the dewpoint.

31.24.8 Weigh in open air at intervals on an analytical balance, recording the weight of the dish 5 min after the rate of loss has decreased to 0.5 mg/min.

NOTE 120—This weight is in grams as  $W_2$ .

31.24.9 Add a plastic-covered magnetic stirring bar and 100 mL of (1 + 1) nitric acid to a 400-mL beaker.

31.24.10 While magnetically stirring the acid, cautiously add the extracted sample from the extraction thimble. Stir until the sample is dissolved or until it is apparent that practically no more sample will dissolve.

31.24.11 Cool to about room temperature and transfer to a 500-mL separatory funnel. Add 100.0 mL of chloroform, stopper tightly, and shake as vigorously as possible for 60 s.

31.24.12 Allow the phases to separate.

NOTE 131—If emulsions form, transfer to centrifuge tubes and centrifuge to separate the phases.

31.24.13 Drain off the lower phase. If the lower phase is the chloroform layer, filter through a phase-separator filter paper into a graduated cylinder or narrow-neck flask. If the lower phase is the aqueous phase, drain and discard. Then filter the upper phase through a phase-separator filter paper into a graduated cylinder or narrow-neck flask.

31.24.14 Transfer 50.0 mL of the filtered chloroform into an ignited (900°C) platinum dish.

31.24.15 Place the platinum dish in a hood and evaporate until about 1 mL of chloroform remains. This evaporation may be done as described in 31.24.6.

31.24.16 Allow the dish to cool to room temperature while tilting and rotating it to spread the last few drops uniformly over the bottom.

31.24.17 Weigh in open air on a recording balance or at intervals on an analytical balance, recording the weight of the dish 5 min after the rate of weight loss has decreased to 0.5 mg/min.

NOTE 142—This weight is in grams as  $W_3$ .

31.24.18 Ignite the platinum dish at 900°C for a minimum of 30 min, cool to room temperature, and weigh.

NOTE 153—This weight is in grams as  $W_4$ .

## 325. Calculation

325.1 Calculate the percentage of extractable organic material,  $O_m$ , as follows:

$$O_m = \frac{100 [(W_2 - W_1) + 2 (W_3 - W_4)]}{S_w} \quad (4)$$

where:

$W_2$  = weight of platinum dish in 31.8; 24.8, g,

$W_1$  = weight of platinum dish in 31.6; 24.6, g,

$W_3$  = weight of platinum dish in 31.17; 24.17, g,

$W_4$  = weight of platinum dish in 31.18; 24.18, g, and

$S_w$  = weight of sample.

~~33.~~

## **26. Precision and Bias**

~~33.1~~

~~26.1 Precision~~—A relative standard deviation for this test method has been reported as 18 % at the 0.1 % extractable organic level (see 4.2).

~~33.2~~

~~26.2 Bias~~—For information on the bias of this test method see 4.2.

## **ARSENIC BY DIETHYLDITHIOCARBAMATE (PHOTOMETRIC) METHOD**

~~34.~~

## **27. Scope**

~~3427.1~~ This test method covers the determination of arsenic in uranium-ore concentrate.

~~3427.2~~ Sample aliquots containing up to 25 µg of arsenic may be analyzed by this test method.

~~35.~~

## **28. Summary of Test Method**

~~3528.1~~ Arsenic compounds are reduced to gaseous arsine by hydrogen generated by zinc in an acid medium. The resulting mixture of gases is passed through a scrubber containing borosilicate wool impregnated with lead acetate solution, and then into an absorption tube containing a solution of silver diethyldithiocarbamate dissolved in pyridine. Arsine reacts with this reagent to form a soluble red substance having maximum absorbance at 540 nm. The absorbance of the solution is measured spectrophotometrically and the arsenic determined by reference to a calibration curve prepared from standards.

~~36.~~

## **29. Interferences**

~~3629.1~~ Although many samples are relatively free of interferences, cobalt, nickel, mercury, silver, platinum, copper, chromium, and molybdenum may interfere with the evolution of arsine and with the recovery of arsenic. The presence of any or all of these metals in a sample being analyzed must be considered as a potential source of interference and the analyst must be aware of the extent of actual interferences if any.

~~3629.2~~ Hydrogen sulfide and other sulfides interfere, but commonly encountered quantities are effectively removed by the lead-acetate scrubber.

~~3629.3~~ Antimony interferes by forming stibine which distills along with the arsine. Stibine reacts with the color-forming reagent to form a red compound having maximum absorbance at 510 nm. The absorbance for antimony at 540 nm is about 8 % of that of arsenic for equal concentrations.

## **370. Apparatus**

~~370.1~~ *Arsine Generator, Scrubber, and Absorber.*

~~37.2~~<sup>10</sup>

~~30.2~~ *Spectrophotometer*, with 1-cm cells in accordance with Practice E 60.

## **381. Reagents**

~~381.1~~ *Arsenic Solution, Standard I* (1 mg As/mL)—Dissolve 1.320 g of arsenic trioxide (As<sub>2</sub>O<sub>3</sub>) (**Warning**, Note ~~16~~ 14) dried for at least 1 h at 110°C, in 10 mL of 10 M sodium hydroxide (NaOH) solution and dilute to 1 L with water. This solution is stable.

NOTE 16~~4~~—**Warning:** Arsenic trioxide is extremely toxic. Avoid ingestion.

~~381.2~~ *Arsenic Solution, Standard II* (10 µg As/mL)—Dilute 5 mL of arsenic standard solution I to 500 mL with water in a volumetric flask.

~~381.3~~ *Arsenic Solution, Standard III* (1 µg As/mL)—Dilute 10 mL of arsenic standard solution II to 100 mL with water in a volumetric flask. Prepare freshly before each use.

~~381.4~~ *Hydrochloric Acid* (HCl, sp gr 1.19)—Use analytical grade acid with an arsenic content no greater than 0.01 µg/mL.

<sup>10</sup> Whatman brand size 33 by 94 mm has been found suitable.

<sup>10</sup> An adequate system can be obtained from laboratory supply houses.

381.5 *Lead Acetate Solution* (100 g/L)—Dissolve 10 g of lead acetate ( $\text{Pb}(\text{C}_2\text{H}_3\text{O}_2)_2 \cdot 3\text{H}_2\text{O}$ ) in water and dilute to 100 mL. Store reagent in a tightly stoppered container.

381.6 *Nitric Acid* (1 + 1)—Add 250 mL of nitric acid ( $\text{HNO}_3$ , sp gr 1.42) to 250 mL of water and mix.

381.7 *Perchloric Acid*—( $\text{HClO}_4$ , 62 %), use analytical-grade acid with an arsenic content no greater than 0.01  $\mu\text{g}/\text{mL}$ .

381.8 *Potassium Iodide Solution* (150 g/L)—Dissolve 15 g of KI in water and dilute to 100 mL. Store in an amber bottle.

381.9 *Silver Diethyldithiocarbamate - Pyridine Solution* (5 g/L)—Dissolve 0.5 g of silver diethyldithiocarbamate in 100 mL of pyridine. This solution is stable for at least several months when stored in an amber bottle.

381.10 *Sodium Hydroxide Solution* (420 g/L)—Dissolve 42 g of NaOH pellet in water and dilute to 100 mL.

381.11 *Stannous Chloride - Hydrochloric Acid Solution* (400 g/L)—Dissolve 40 g of arsenic-free  $\text{SnCl}_2 \cdot 2\text{H}_2\text{O}$  in 100 mL of HCl (sp gr 1.19). Add a few small pieces of mossy tin.

381.12 *Zinc* (*Granular*, 20 mesh)—Arsenic content must not exceed 1  $\mu\text{g}$  of arsenic per gram of zinc.

381.13 *Sulfuric Acid* ( $\text{H}_2\text{SO}_4$ , sp gr 1.84)—Use analytical-grade acid with an arsenic content no greater than 0.01  $\mu\text{g}/\text{mL}$ .

### **392. Precautions**

392.1 Take proper precautions to prevent inhalation or ingestion of arsine, arsenic, or pyridine during the analysis. Furthermore, do not allow the pyridine to contact the skin.

~~40.~~

### **33. Calibration**

4033.1 Clean all glassware before use by rinsing first with hot (1 + 1)  $\text{HNO}_3$ , then with water. Also, rinse the absorbers with acetone and air dry.

4033.2 Prepare a blank and a series of standards by pipetting appropriate volumes of arsenic standard solution III (**Caution**, Note ~~16~~ 14) into arsine-generating flasks. The standards should cover the range from 0 to 25  $\mu\text{g}$  of arsenic.

4033.3 Dilute each standard and blank to approximately 25 mL.

4033.4 Add successively to each flask, with thorough mixing after each addition, 5 mL of HCl (sp gr 1.19), 2 mL of KI solution, and 8 drops of  $\text{SnCl}_2$  solution. Let stand about 15 min to allow the arsenic to completely reduce to the trivalent state.

4033.5 Place in each scrubber a plug of borosilicate wool that has been impregnated with lead acetate solution. Assemble the generator, scrubber, and absorber, making certain that all parts fit and are correctly adjusted. Add 3.00 mL of silver diethyldithiocarbamate - pyridine solution to each absorber, then add glass beads to the absorbers until the liquid just covers them.

4033.6 Disconnect each generator, add 3 g of zinc, and reconnect immediately.

4033.7 Allow 30 min for complete evolution of arsine. Warm the generator flasks for a few minutes to make sure all arsine is released.

4033.8 Pour the solutions from the absorbers directly into clean spectrophotometer cells and, within 30 min, measure the absorbance of each at 540 nm using water in the reference cell.

4033.9 Prepare a calibration curve by plotting micrograms of arsenic against the corresponding absorbance of each standard after correcting for the blank.

### **34. Procedure**

34.1 Clean all glassware by rinsing with hot (1 + 1)  $\text{HNO}_3$  before use.

34.2 Weigh 1 g of uranium-ore concentrate into a 250-mL Erlenmeyer flask. Add 12 mL of  $\text{H}_2\text{SO}_4$ , 5 mL of  $\text{HClO}_4$ , and 5 mL (1 + 1)  $\text{HNO}_3$ . Boil the sample on a hot plate until the fumes of the  $\text{H}_2\text{SO}_4$  just begin to come off. Cool, transfer to a 100-mL volumetric flask, and dilute to volume with water.

34.3 Pipet an aliquot of sample containing less than 25  $\mu\text{g}$  of arsenic (25 mL maximum) from the volumetric flask into a generating flask and dilute to approximately 25 mL.

34.4 Proceed as directed in ~~40~~ 33.4-4033.8.

34.5 Determine the reagent blank by repeating the procedure in 34.1-34.4, but omit the sample in 34.2 and take the same aliquot in 34.3 as was used for the sample.

34.6 Subtract the reagent blank from the absorbance of the sample aliquot, then determine the amount of arsenic in the sample aliquot by reference to the calibration curve prepared in ~~40~~ 9.

~~42.~~ **33.9.**

### **35. Calculation**

4235.1 Calculate the percentage of arsenic concentration,  $A$ , in the sample as follows:

$$A = \frac{W}{G \times V \times 100} \quad (5)$$

where:

$W$  = amount of arsenic in sample aliquot as determined from the calibration curve,  $\mu\text{g}$ ,

$G$  = amount of sample taken, g, and

$V$  = volume of aliquot taken in 344.3, mL.

4235.2 Calculate the percentage of arsenic concentration,  $A_u$ , in the sample on a uranium basis as follows:

$$A_u = \frac{A \times 100}{U} \quad (6)$$

where:

$A$  = arsenic concentration calculated in 42.2, 35.2, %, and

$U$  = uranium in sample, %.

#### **436. Precision and Bias**

436.1 *Precision*—A relative standard deviation has been reported as 4 % at the 0.1 % arsenic level (see 4.2).

436.2 *Bias*—For information on the bias of this test method see 4.2.

### **CARBONATE BY CO<sub>2</sub> GRAVIMETRY**

~~44.~~

#### **37. Scope**

4437.1 This test method covers the determination of 0.1 to 3 % carbonate in uranium-ore concentrate.

4437.2 The concentration range can be extended by taking smaller sample weights.

~~45.~~

#### **38. Summary of Test Method**

4538.1 The carbonate in the sample is decomposed with hydrochloric acid and evolved as carbon dioxide. The incoming air is dried and the CO<sub>2</sub> is removed by passing it through NaOH and anhydrous calcium sulfate (CaSO<sub>4</sub>). The evolved gases are scrubbed in H<sub>2</sub>SO<sub>4</sub> to remove moisture and passed through a tower of manganese dioxide and zinc metal to remove any SO<sub>2</sub> or H<sub>2</sub>S formed. The evolved gas is then absorbed by NaOH in a Nesbitt bulb and determined gravimetrically (6).

~~46.~~

#### **39. Apparatus**

~~46.1~~

39.1 *Carbonate Apparatus*, (see Fig. 2).

#### **470. Reagents**

470.1 *Sodium Hydroxide Coated Non-Fibrous Silicate*, indicating (Ascarite II).

~~47.2~~<sup>11</sup>

40.2 *Anhydrous Calcium Sulfate*, indicating (Drierite).

~~47.3~~<sup>10</sup>

40.3 *Glass Wool*.

470.4 *Manganese Dioxide*, granular.

470.5 *Zinc Metal*, granular.

470.6 *Sulfuric Acid* (H<sub>2</sub>SO<sub>4</sub>, sp gr 1.84).

470.7 *Hydrochloric Acid* (5.5 M)—Dilute 50 mL of HCl (sp gr 1.19) to 100 mL with water.

#### **481. Procedure**

481.1 Weigh a sample (maximum of 5 g) to the nearest 0.01 g. The sample should contain approximately 20 mg CO<sub>2</sub>. Transfer to an Erlenmeyer flask and add enough water to cover the inlet tube.

481.2 Attach the Nesbitt bulb, open the stopper and pass air through the apparatus for 10 to 15 min at the rate of 2 to 3 bubbles/s.

NOTE 175—Measure the flow rate at the H<sub>2</sub>SO<sub>4</sub> moisture trap.

481.3 Remove the Nesbitt bulb without altering the air flow. Close the stopper and weigh the bulb to nearest 0.1 mg.

481.4 Open the stopper of the bulb and replace it on the apparatus.

<sup>11</sup> Whatman IPS has

<sup>11</sup> Ascarite II and Drierite have been found to be acceptable for this application. They are, respectively, the trademarks of Arthur H. Thomas and W. A. Hammond Drierite Companies.

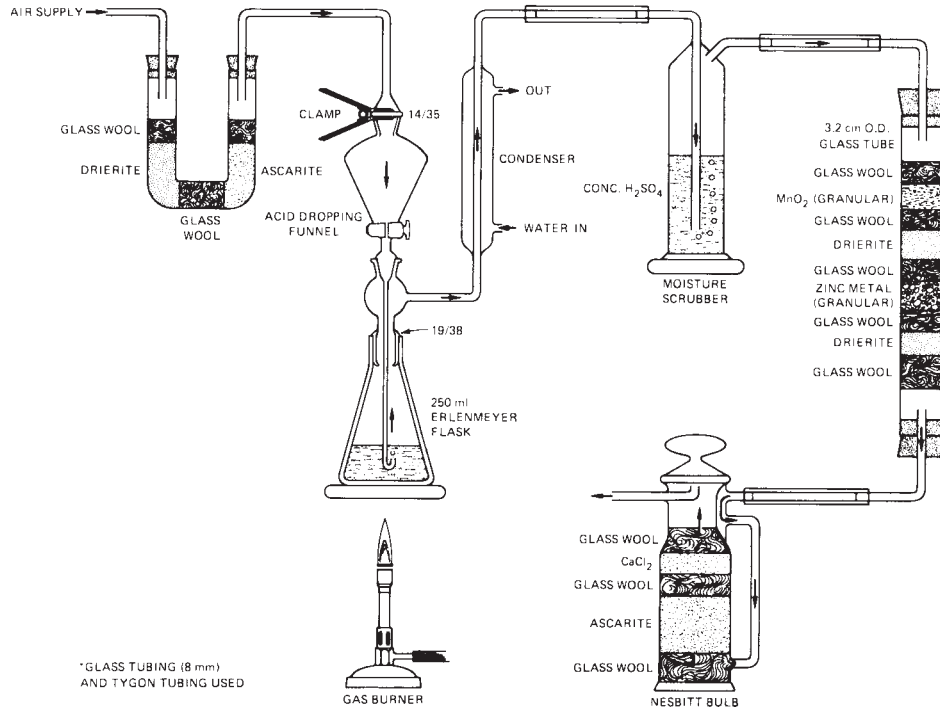

FIG. 2 Carbonate Apparatus

481.5 Place 25 mL of 5.5 M HCl in the dropping funnel and force it into the flask by replacing the air inlet tube.

NOTE 186—If the uranium-ore concentrate was produced as a uranium peroxide, replace 25 mL of 5.5 M HCl with 25 mL of 5.5 M H<sub>2</sub>SO<sub>4</sub> to prevent the release of chlorine.

481.6 Heat the Erlenmeyer flask with a small burner until the acid boils and adjust the burner to maintain gentle boiling.

481.7 Boil for 15 min, then shut off the flame.

481.8 Continue to pass air through the apparatus for an additional 10 min.

481.9 Remove the Nesbitt bulb and close the stopper immediately.

481.10 Reweigh the Nesbitt bulb to the nearest 0.1 mg.

481.11 Remove the Erlenmeyer flask from the apparatus while air is still flowing.

NOTE 197—Leave the air on until the flask is removed to prevent suck-back of the H<sub>2</sub>SO<sub>4</sub>.

481.12 Repeat the procedure in 481.1-481.10, without a sample, to obtain a blank.

## 492. Calculation

492.1 Calculate the percentage of carbonate, C<sub>a</sub>, for the sample and the blank as follows:

$$C_a = \frac{136.36(B-C)}{A} \quad (7)$$

where:

A = sample weight, g,

B = weight of Nesbitt bulb after absorption of CO<sub>2</sub>, g, and

C = weight of Nesbitt bulb before absorption of CO<sub>2</sub>, g.

492.2 Correct the percentage of CO<sub>3</sub> obtained on the sample for a blank.

492.3 Calculate the weight percentage of carbonate, C<sub>u</sub>, on a uranium basis as follows:

$$C_u = \frac{C_c \times 100}{U} \quad (8)$$

where:

C<sub>c</sub> = corrected percentage of carbonate in the sample (see 492.2), and

U = uranium in the sample, %.

50.—

## 43. Precision and Bias

50.1—

- 43.1 *Precision*—A relative standard deviation for this test method has been reported at 5 % at 1.0 % carbonate level (see 4.2).  
 50.2—  
 43.2 *Bias*—For information about the bias of this test method see 4.2.

**FLUORIDE BY ION-SELECTIVE ELECTRODE**

51.—

**44. Scope**

5144.1 This test method covers the determination of fluoride in uranium-ore concentrates.

**452. Summary of Test Method**

452.1 The fluoride is separated pyrohydrolytically by passing a stream of moist oxygen over a mixture of sample and fluoride-free uranium oxide (U<sub>3</sub>O<sub>8</sub>) in a reactor tube at 850°C. (The U<sub>3</sub>O<sub>8</sub> acts as an accelerator in the presence of high concentrations of sodium, calcium, or magnesium.) The HF formed is absorbed in a dilute solution of sodium hydroxide and the fluoride ion concentration is measured with an ion-selective electrode (7, 8, 9).

53.—

**46. Interferences**

5346.1 At the specification limit for fluoride, interference effects are insignificant.

**547. Apparatus**

547.1 *Pyrohydrolysis Apparatus*, (see Fig. 3).

547.2 *Gas-Flow Regulator and Flowmeter*.

547.3 *Three-Necked 1-L Flask*.

547.4 *Gas Diffuser*.

547.5 *Thermometer*.

547.6 *Male Ball-Joint Connector*.

547.7 *Heating Mantle*, for 1-L flask, controlled by variable transformer.

547.8 *Furnace*—A tube furnace capable of maintaining a temperature of 850°C. The bore of the furnace should be a minimum of 32 mm (1¼ in.) in diameter and 330 mm (13 in.) in length.

547.9 *Reactor Tube*, made from clear silica about 30 mm (1½ in.) in diameter and 460 mm (18 in.) in length having a female ball-joint connector at the entrance end and a delivery tube 9.5 mm (¾ in.) in diameter and 150 mm in length fused at right angles to the exit end.

547.10 *Absorption Vessels*—50-mL glass test tubes.

547.11 *Combustion Boat*—A quartz boat with 10-mL capacity and dimensions (100 mm long, 15 mm wide, and 10 mm deep).

547.12 *Fluoride-Ion Selective Electrode*.

547.13 *Millivolt Meter*, with saturated calomel reference electrode capable of reading to 1 mV.

547.14 *Magnetic Stirrer*.

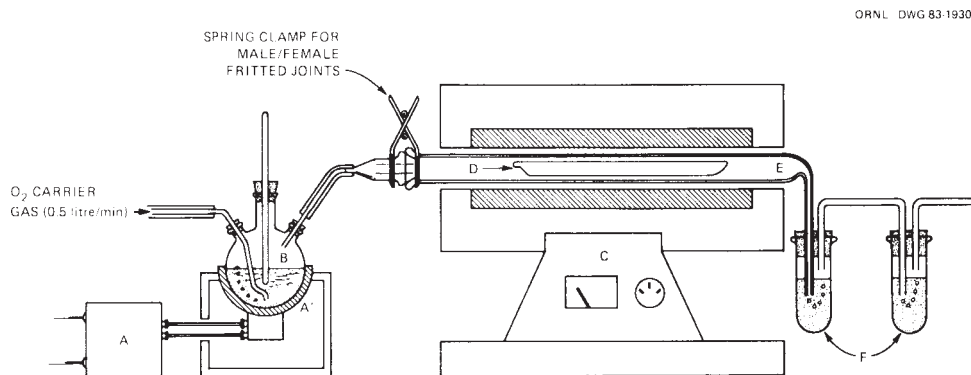

A, A'—Heating jacket controlled by variable transformer. Nominal temperature 80 to 85°C for water.  
 B—One-liter three-necked with gas diffuser and thermometer 0 to 110°C. D.D. water used.  
 C—Tube furnace, controlled by variable transformer with thermocouple. Operating temperature 850 ± 25°C.  
 D—Sample boat.  
 E—Pyrohydrolytic tube.  
 F—Collection system; 10 mL of 0.2 N sodium hydroxide in first tube, 10 to 15 mL of water in second tube.

**FIG. 3 Pyrohydrolysis Apparatus**

55.—

#### 48. Reagents

55.1—

48.1 *Accelerator*—Fluoride-free uranium oxide ( $U_3O_8$ ).

55.2—

48.2 *Sodium Hydroxide Solution* (NaOH, 0.2 N)—Dissolve 8 g of NaOH in distilled water and dilute to 1 L.

55.3—

48.3 *Buffer Solution* (0.001 N)—Dissolve 0.1 g of potassium acetate ( $KC_2H_3O_2$ ) in water. Add 0.050 mL of acetic acid (sp gr 1.05) and dilute to 1 L.

55.4—

48.4 *Fluoride Solution, Standard* (1 mL = 10  $\mu$ g F)—Dissolve in water 0.221 g of sodium fluoride (NaF) previously dried at 110°C and dilute to 1 L in a volumetric flask. Pipet 10.0 mL of this solution into a 100-mL volumetric flask and dilute to volume with water. Mix and transfer the solution to a plastic container.

56.—

#### 49. Procedure

5649.1 Adjust the pyrohydrolysis system to operating conditions as follows:

5649.1.1 Place the reactor tube in the furnace with the delivery tube as close as possible to the end (5 to 10 mm).

5649.1.2 Turn on the furnace and allow it to reach 850°C. Adjust the controls to maintain this temperature within  $\pm 25$  °C.

5649.1.3 Fill the three-necked flask half full with water.

5649.1.4 Place the flask on the heating mantle, then connect the gas diffuser to the flowmeter and the female socket to the reactor tube with a spring clamp.

5649.1.5 Adjust the control on the heating mantle to bring the temperature of the water to 80 to 85°C.

5649.1.6 Turn on the oxygen and adjust the flow to 500 mL/min. Flush the apparatus in this manner for 10 to 15 min.

5649.2 Weigh  $4 \pm 0.01$  g of powdered sample, mix thoroughly with 8 g of  $U_3O_8$  accelerator, and place in a sample boat.

NOTE 20—A 18—A blank of 8 g  $U_3O_8$  is run in a separate boat.

5649.3 Connect the collection system. The collection system consists of two 50-mL test tubes in series. The first tube contains 10 mL of 0.2 N NaOH. The second tube contains 10 to 15 mL of water. The first tube is fitted with a two-holed stopper through which is passed the quartz delivery tube from the pyrohydrolysis apparatus and a glass inverted U-tube leading to the second tube. The gas stream escaping from the first tube during pyrohydrolysis is carried through the inverted U-tube into the water in the second test tube. Sufficient back pressure is created to ensure that all the fluoride is absorbed in the first tube.

NOTE 219—The delivery tube tip should be immersed to a depth of 15 mm below the surface of the NaOH solution.

5649.4 Position the sample boat in the middle of the reactor tube and immediately close the tube.

5649.5 Pyrohydrolyze for 60 min.

5649.6 Remove the first test tube containing NaOH solution and rinse the delivery tube with distilled water into the tube.

5649.7 Transfer the contents of the test tube to a 25-mL volumetric flask. Dilute to mark and mix.

5649.8 Pipet 1 mL into a 100-mL plastic beaker, add 24 mL of water and 25 mL of buffer solution.

5649.9 Place in a magnetic stirrer and insert the electrode pair.

5649.10 Set the meter at the millivolt setting and stir the sample solution until a stable reading is reached. Record the millivolt reading.

5649.11 Rinse electrodes with water and dry with absorbent tissue.

5649.12 Read all samples and blank.

5649.13 Prepare a calibration curve by adding, to separate 100-mL plastic beakers, the following amounts of fluoride standard solution (1 mL = 10  $\mu$ g of fluoride): 0, 0.1, 0.5, 1.0, 2.0, 3.0, 4.0, and 5.0 mL. Dilute to 25 mL with distilled water. Add 25 mL of buffer solution just prior to measuring each standard individually as in 56.15 and 56.16. Plot mV readings against micrograms of fluoride using log/linear graph paper.

#### 570. Calculation

570.1 Calculate the percentage of fluoride,  $F$ , as follows:

$$F = \frac{(C_s - C_B)}{W \times 400} \quad (9)$$

where:

$C_s$  = fluoride from the calibration curve for the sample,  $\mu$ g,

$C_B$  = fluoride from the calibration curve for the blank,  $\mu$ g, and

$W$  = sample weight, g.

570.2 Calculate the percentage of fluoride,  $F_u$ , on a uranium basis as follows:

$$F_u = \frac{F \times 100}{U} \quad (10)$$

where:

$F$  = fluoride (see 570.1), %, and

$U$  = uranium in sample, %.

### 581. Precision and Bias

581.1 *Precision*—A relative standard deviation has been reported as 7 % at the 0.05 % fluoride level (see 4.2).

581.2 *Bias*—For information on the bias of this test method see 4.2.

## HALIDES BY VOLHARD TITRATION

### 592. Scope

592.1 This test method covers the determination of halides except fluoride in uranium-ore concentrates.

~~60.~~

### 53. Summary of Test Method

~~60.1-A~~

53.1 A sample of ore concentrate is digested in dilute  $\text{HNO}_3$  without boiling. A known amount of standard silver nitrate solution is added and the silver halide precipitates that are formed are filtered. The excess silver nitrate in the filtrate is titrated with a standard potassium thiocyanate solution using ferric ammonium sulfate as indicator. The halide content of the sample is expressed as a chloride equivalent.

~~61.~~

### 54. Apparatus

~~61.1~~

~~54.1~~ *Filter Paper.*

~~62.~~<sup>12</sup>

### 55. Reagents

~~62.1~~

55.1 *Silver Nitrate Solution, Standard* (0.0500  $N$ )—Weigh exactly 8.494 g of finely powdered silver nitrate ( $\text{AgNO}_3$ ), dried at  $110^\circ\text{C}$ , into a 250-mL beaker. Dissolve the salt in water and dilute to exactly 1 L. Store the reagent in an amber-colored bottle.

~~62.2~~

55.2 *Potassium Thiocyanate Solution, Standard* (0.025  $N$ )—Dissolve 2.43 g of potassium thiocyanate ( $\text{KSCN}$ ) in 1 L of water.

~~62.3~~

55.3 *Nitric Acid* ( $\text{HNO}_3$ , sp gr 1.42).

~~62.4~~

55.4 *Nitric Acid Solution* (1 + 4)—Add 200 mL of  $\text{HNO}_3$  (sp gr 1.42) to 500 mL of water and boil to remove oxides of nitrogen. Dilute the cooled solution to 1 L with water.

~~62.5~~

55.5 *Ferric Ammonium Sulfate Indicator Solution*—Add 50 g of ferric ammonium sulfate to 200 mL of water and heat gently to dissolve. Add  $\text{HNO}_3$  (sp gr 1.42) dropwise, while stirring, until the color of the solution changes from brown to pale yellow.

### 563. Standardization of Potassium Thiocyanate Solution

563.1 Pipet individual 10-mL aliquots of the 0.0500  $N$  silver nitrate solution into two 250-mL beakers.

563.2 Add 25 mL of  $\text{HNO}_3$  (1 + 4) solution and 10 mL of ferric ammonium sulfate indicator solution to each beaker.

563.3 Titrate with the potassium thiocyanate solution to the first permanent reddish-brown end point.

$$\text{Normality of KSCN} = \frac{0.5}{\text{mean titre (mL)}} \quad (11)$$

<sup>12</sup> An adequate system can be obtained from laboratory supply houses.

<sup>12</sup> Whatman No. 42 has been found suitable.

~~64.~~

### 57. Procedure

6457.1 Add 25 mL of boiled nitric acid solution to a  $2.00 \pm 0.01$ -g sample and heat for 20 min at low heat. Do not boil. (If insoluble residue is evident, filter through filter paper using a small amount of paper pulp.)

6457.2 Add 5.0 mL of the  $\text{AgNO}_3$  standard solution by pipet and stir thoroughly. Heat at low heat until the precipitate coagulates.

6457.3 Filter off the precipitated silver halides using filter paper.<sup>11</sup> Wash the beaker and filter paper with water.

6457.4 Add 10 mL of ferric ammonium sulfate indicator solution to the filtrate and titrate the excess  $\text{AgNO}_3$  with the KSCN standard solution to the first permanent ferric thiocyanate color.

### 658. Calculation

658.1 Calculate the percentage of halides (expressed as chloride),  $H$ , as follows:

$$H = \frac{0.177 [A - (B \times C)]}{S} \quad (12)$$

$$H = \frac{0.177 [A - (B \times C)]}{S} \quad (12)$$

where:

$A$  = 0.0500  $N$   $\text{AgNO}_3$  added, mL,

$B$  = 0.025  $N$  KSCN added, mL,

$C$  = KSCN factor, the actual normality of KSCN (see 563.3) divided by 0.0500,

0.177 = mg chloride/mL (0.0500  $N$ )  $\text{AgNO}_3$ , and

$S$  = sample weight, g.

658.2 Calculate the percentage of halides,  $H_u$ , on a uranium basis as follows:

$$H_u = \frac{H \times 100}{U} \quad (13)$$

where:

$H$  = halide from 658.1, %, and

$U$  = uranium in the sample, %.

~~66.~~

### 59. Precision and Bias

~~66.1~~

59.1 *Precision*—A relative standard deviation for this test method has been reported as 25 % at 0.10 % chloride level (see 4.2).

~~66.2~~

59.2 *Bias*—For information on the bias of this test method see 4.2.

## MOISTURE BY LOSS OF WEIGHT AT 110°C

### 670. Scope

670.1 This test method provides a means of process control used to estimate the moisture content of the material before shipment; and a means of determining the moisture content of a sample for the purpose of correcting impurity analyses where necessary.

670.2 Moisture, for contractual purposes, is usually determined during the course of ore-concentrate sampling as part of the procedure agreed upon between the supplier and the purchaser.

### 681. Summary of Test Method

681.1 A weighed portion of the sample is placed into a well-sealed oven that is fitted with an entry and exit port for the passage and circulation of dry air. The oven atmosphere is composed of dry air under a slight positive pressure. The sample is heated, then removed, cooled, weighed, and the loss in weight observed.

681.2 This procedure is repeated until the weight becomes constant or the loss in weight becomes insignificant.

### 692. Apparatus

692.1 *Drying Oven*, with inlet and outlet ports.

692.2 *Desiccator*.

692.3 *Vacuum Pump*.

692.4 *Wide-Mouth Weighing Bottles*, with covers, bottle size 40 by 50 mm.

~~692.5 Drying Tube.~~

~~70.—~~

### **63. Reagents**

~~70.1—~~

~~63.1 Anhydrous Calcium Sulfate, (Drierite).~~

~~71.—~~

### **64. Procedure**

~~71.64.1~~ Transfer a 5-g sample of the ore concentrate to a tared weighing bottle.

~~71.64.2~~ Weigh the sample and weighing bottle and record the weight to the nearest 0.1 mg.

~~71.64.3~~ Place the sample bottle with the cover removed into the dry-air oven which has been heated to and thermostatically controlled at 110°C.

~~71.64.4~~ Open the oven after 24 h, replace the cover on the bottle, and quickly transfer the sample to a desiccator.

~~71.64.5~~ Allow the sample to cool to room temperature. After approximately 40 min, allow air to enter the desiccator.

~~71.64.6~~ Remove the sample weighing bottle from the desiccator and weigh immediately to the nearest 0.1 mg.

~~71.64.7~~ Return the sample to the oven and repeat ~~71.3–71.6~~ ~~64.3–64.6~~ until no further loss in weight is noted or the change in weight for a 24-h period is less than 0.1 mg.

NOTE 220—Complete drying often requires several days.

~~72.—~~

### **65. Calculation**

~~72.65.1~~ Calculate the percentage of moisture,  $M$ , as follows:

$$M = \frac{(W_2 - W_3) \times 100}{(W_2 - W_1)} \quad (14)$$

where:

$W_1$  = weight of weighing bottle, g,

$W_2$  = weight of weighing bottle plus sample, g, and

$W_3$  = weight of weighing bottle plus dried sample, g.

~~73.—~~

### **66. Precision and Bias**

~~73.1—~~

~~66.1 Precision~~—A standard deviation has been reported as 0.01 % absolute (see 4.2).

~~73.2—~~

~~66.2 Bias~~—For information on the bias of this test method see 4.2.

## **PHOSPHORUS BY SPECTROPHOTOMETRY**

### **674. Scope**

~~674.1~~ This test method covers the determination of phosphorus in uranium-ore concentrates.

~~75.—~~

### **68. Summary of Test Method**

~~75.68.1~~ The phosphorus compounds present in the sample are oxidized by potassium permanganate to orthophosphates in dilute nitric acid solution. Addition of ammonium vanadate and ammonium molybdate produces the colored phospho-vanadomolybdate complex. This complex is extracted from the sample matrix with isoamyl alcohol. The absorbance of the extract is then measured spectrophotometrically at 400 nm (**10** and **11**).

### **769. Interferences**

~~769.1~~ There are no known interferences. A blank is run to compensate for any possible absorbance due to the uranyl ion.

### **770. Apparatus**

~~770.1~~ *Spectrophotometer*, with 1-cm cells in accordance with Practice E 60.

770.2 *Laboratory Shaker*, with clamps to hold 250-mL separatory funnels.

770.3 *Centrifuge*, equipped to handle 15-mL centrifuge tubes.

### 781. Reagents

781.1 *Potassium Permanganate Solution* (1 %)—Dissolve 10 g of potassium permanganate ( $\text{KMnO}_4$ ) in distilled water and dilute to 1 L.

781.2 *Sulfurous Acid* ( $\text{H}_2\text{SO}_3$ )—Saturate distilled water with  $\text{SO}_2$ .

781.3 *Ammonium Vanadate Solution* (0.25 %)—Dissolve 2.5 g of ammonium metavanadate ( $\text{NH}_4\text{VO}_3$ ) in 500 mL of warm water, cool, add 20 mL of  $\text{HNO}_3$  (sp gr 1.42) and dilute to 1 L with water.

781.4 *Ammonium Molybdate Solution* (10 %)—Dissolve 100 g of ammonium molybdate ( $(\text{NH}_4)_6\text{Mo}_7\text{O}_{24}\cdot 4\text{H}_2\text{O}$ ) in about 800 mL of hot water, cool, and dilute to 1 L. Filter if necessary.

781.5 *Isoamyl Alcohol*.

781.6 *Phosphorus Solution, Standard* (1 mL = 100  $\mu\text{g}$  P)—Weigh 4.2638 g of ammonium hydrogen phosphate ( $(\text{NH}_4)_2\text{HPO}_4$ ). Dissolve in water and dilute to 1 L to produce a solution containing 1 mg phosphorus/mL. Dilute 10 mL of 1 mg of phosphorus/mL solution to 100 mL to produce a solution containing 100  $\mu\text{g}$  phosphorus/mL.

### 792. Calibration

792.1 Prepare a calibration curve by adding 0, 10, 20, 30, 40, and 50 mL of phosphorus standard solution (100  $\mu\text{g}$  of phosphorus/mL) to separate 250-mL beakers, each containing 0.5 g of pure  $\text{U}_3\text{O}_8$ .

792.2 Follow ~~80~~ 73.2-~~80~~73.19 of the procedure.

792.3 Plot absorbancies corrected for the blank against milligrams of phosphorus.

~~80.~~

### 73. Procedure

8073.1 Weigh a 0.5 to 1-g sample to the nearest 1 mg into a 250-mL beaker.

NOTE 231—A blank containing the same weight of uranium as the sample should be carried through the procedure. Nuclear grade  $\text{UO}_2$  or  $\text{U}_3\text{O}_8$  is suitable for this purpose.

8073.2 Dissolve the sample in 10 mL of  $\text{HNO}_3$  (sp gr 1.42) by digesting on a hot plate until dissolution is complete.

8073.3 Dilute the solution to approximately 50 to 75 mL with water.

NOTE 242—Some uranium-ore concentrates may produce an insoluble residue of silica, in which case the solution should be filtered through a Whatman No. 541 filter paper or equivalent, and the residue washed well with hot water. The washings should be added to the main filtrate.

8073.4 Transfer the solution to a 500-mL volumetric flask and dilute to volume with water. Pipet a 50-mL aliquot into a 250-mL Erlenmeyer flask.

8073.5 Add 5 mL of 1 %  $\text{KMnO}_4$  solution and boil for 3 min.

8073.6 Add  $\text{H}_2\text{SO}_3$  dropwise until the solution clears.

8073.7 Boil off the excess sulfur dioxide and evaporate the solution to a volume of about 10 mL.

8073.8 Cool the solution and transfer it to a 50-mL stoppered graduated cylinder keeping the volume to about 30 mL after three water washings.

NOTE 253—At this point, ensure that the separatory funnels are clean and ready for use on the shaker. Proceed from this point as rapidly as possible.

8073.9 Add  $5 \pm 0.5$  mL of  $\text{HNO}_3$  (sp gr 1.42) from a graduated cylinder.

8073.10 Add 5 mL of ammonium vanadate solution and mix.

8073.11 Add 5 mL of ammonium molybdate solution, dilute to 50 mL, stopper the cylinder, and shake.

8073.12 Transfer to a 250-mL separatory funnel without washing.

8073.13 Add  $50 \pm 0.5$  mL of isoamyl alcohol.

8073.14 Shake for 5 min.

8073.15 Discard the lower aqueous layer, and let a little solvent run through the spout of the funnel to clean it.

8073.16 Transfer a portion of the organic layer to a 15-mL centrifuge tube.

8073.17 Centrifuge for about 1 min.

8073.18 Measure the absorbance of the organic layer in a 1-cm cell at 400 nm using isoamyl alcohol as the reference.

8073.19 Measure the absorbance of the blank solution and subtract the absorbance from all the sample readings.

8073.20 Using either the calibration curve (see 792.3) or a factor, obtain the phosphorus content in milligrams of the 50-mL aliquot (see ~~80.4~~):

~~81.~~ 73.4.

### 74. Calculation

~~81~~74.1 Calculate the percentage of phosphorus, *P*, as follows:

$$P = \frac{C}{W} \quad (15)$$

where:

$C$  = phosphorus in the aliquot (see ~~80.20~~, 73.20), mg, and

$W$  = weight of sample, g.

~~81~~74.2 Calculate percentage of phosphorus,  $P_u$ , on a uranium basis as follows:

$$P_u = \frac{100 C}{W \times U} \quad (16)$$

where:

$C$  = phosphorus in the aliquot, mg,

$W$  = weight of sample, g, and

$U$  = uranium in the sample, %.

~~82.~~

### 75. Precision and Bias

~~82.1~~

75.1 Precision—A relative standard deviation has been reported as 6 % at 0.5 % phosphorus level, and 25 % at 0.05 % phosphorus level (see 4.2).

~~82.2~~

75.2 Bias—For information on the bias of this test method see 4.2.

## SILICON BY GRAVIMETRY

~~83.~~

### 76. Scope

8376.1 This gravimetric method is applicable to the determination of silicon in uranium-ore concentrates when present in concentrations in excess of 200 ppm.

~~84.~~

### 77. Summary of Test Method

~~84.1 A~~

77.1 A pulverized sample of the ore concentrate is dissolved in nitric and hydrochloric acids. The silicon in the solution is dehydrated in an acid medium, ignited, and weighed as silica ( $\text{SiO}_2$ ). The silica obtained is impure and the amount present is determined gravimetrically by difference after volatilization as silicon tetrafluoride ( $\text{SiF}_4$ ).

### 785. Apparatus

785.1 *Platinum Crucibles*, 50-mL capacity.

785.2 *Hot Plate*.

785.3 *Muffle Furnace*.

785.4 *Filter Paper*.

~~86.~~<sup>11</sup>

### 79. Reagents

~~86.1~~

79.1 *Hydrochloric Acid*, HCl (sp gr 1.19).

~~86.2~~

79.2 *Nitric Acid*,  $\text{HNO}_3$  (sp gr 1.42).

~~86.3~~

79.3 *Perchloric Acid*,  $\text{HClO}_4$  (sp gr 1.67).

~~86.4~~

79.4 *Hydrofluoric Acid*, HF (48 %).

~~86.5~~

79.5 *Sulfuric Acid*,  $\text{H}_2\text{SO}_4$  (sp gr 1.84).

~~86.6~~

79.6 *Hydrochloric Acid (0.1 M)*—Add 8.3 mL of HCl (sp gr 1.19) to water and dilute to 1 L.

## 870. Procedure

- 870.1 Weigh between 2 and 5 g of sample, to the nearest 1 mg, into a 400-mL beaker.  
 870.2 Add 10 mL of HNO<sub>3</sub> and 40 mL HCl and digest on a hot plate for 20 to 30 min.  
 870.3 Add 10 mL HClO<sub>4</sub> and 10 mL HNO<sub>3</sub> and place on a hot plate.  
 870.4 Evaporate the solution until copious white fumes of HClO<sub>4</sub> are produced and then boil gently for 10 to 15 min. Do not allow the contents of the beaker to become solid.

NOTE 264—**Warning:** This is a hazardous operation and should be carried out in a fume hood approved for HClO<sub>4</sub> work and behind a shatter-proof screen. Organic matter can react explosively with perchlorates under certain conditions.

- 870.5 Remove the beaker from the hot plate, allow to cool, and dilute the sample with 20 to 30 mL of water.  
 870.6 Heat the sample to boiling on a hot plate, then filter through filter paper using macerated filter pulp to assist the filtration.  
 870.7 Wash the filter paper and residue thoroughly with ten 10-mL portions of 0.1 M HCl to remove all traces of perchlorates.  
 870.8 Place the filter paper and residue into a platinum crucible. Burn off the paper, and then ignite in a muffle furnace for 1 h at 950°C.  
 870.9 Remove the crucible from the furnace, cool slightly, and place in a desiccator.  
 870.10 After cooling to room temperature, weigh the residue and crucible to the nearest 0.1 mg. Record this value as W<sub>1</sub>.  
 870.11 Add 1 mL of H<sub>2</sub>SO<sub>4</sub> and 5 mL of HF to the residue contained in the crucible.  
 870.12 Place the crucible on a hot plate and gently evaporate the solution down to copious fumes of sulfur trioxide and continue until all fumes have been evolved.  
 870.13 Ignite the crucible at 950°C for 1 h.  
 870.14 Remove the crucible from the furnace, cool slightly, and place in a desiccator until the crucible has cooled to room temperature.  
 870.15 Weigh the crucible plus the residue to the nearest 0.1 mg. Record the weight as W<sub>2</sub>.

## 881. Calculation

- 881.1 Calculate the percentage of silicon, S, as follows:

$$S = \frac{46.72 (W_1 - W_2)}{W_3} \quad (20)$$

$$S = \frac{46.72 (W_1 - W_2)}{W_3} \quad (17)$$

where:

- W<sub>1</sub> = weight of crucible and total residue, g,  
 W<sub>2</sub> = weight of crucible and hydrofluoric acid-treated residue, g, and  
 W<sub>3</sub> = weight of sample, g.

- 881.2 Calculate the percentage of silicon, S<sub>u</sub>, on a uranium basis as follows.

$$S_u = \frac{S_i \times 100}{U} \quad (18)$$

where:

- S<sub>i</sub> = silicon from 881.1, %, and  
 U = uranium in sample, %.

## 892. Precision and Bias

- 892.1 *Precision*—A relative standard deviation has been reported as 5 % at the 0.5 % silicon level (see 4.2).  
 892.2 *Bias*—For information on the bias of this test method see 4.2.

## THORIUM BY THE THORIN (PHOTOMETRIC) METHOD

## 9083. Scope

9083.1 This test method is applicable for the determination of natural thorium in uranium-ore concentrates. This test method is suitable for the determination of 0.05 % thorium and higher (uranium basis).

91.—

## 84. Summary of Test Method

91.1—A

84.1 A sample of uranium-ore concentrate containing thorium is dissolved by digestion with mixed acids. Nitric acid (1 + 1) is added to the solution which is then passed through an ion-exchange column. Thorium is eluted with 3 M hydrochloric acid. The eluate is evaporated and diluted to volume with 0.33 M hydrochloric acid. Thorin reagent is added to a suitable aliquot and the absorbance measured at 545 nm.

92.—

### 85. Interferences

9285.1 Zirconium and uranium are potential interferences but are effectively removed by the ion exchange separation. Anions, which form complexes with thorium, such as sulfate, phosphate, and fluoride are potential interferences but their effect is minimized in nitric acid solution.

93.—

### 86. Apparatus

93.1—

86.1 *Chromatographic Columns*—The columns should be made of borosilicate-glass tubing having a 10.5-mm inside diameter and should be 250 mm in length. The column is fitted with a Teflon<sup>13</sup> stopcock at the bottom and a 200-mL reservoir at the top.

93.2—

86.2 *Spectrophotometer*—The spectrophotometer must be suitable for use at 545 nm and provide a light path of at least 1 cm. The photometric practices described in this test method should conform to Practice E 60 and the spectrophotometer shall conform to Practice E 275.

94.—

### 87. Reagents

94.1—

87.1 *Ion Exchange Resin AG1-X8 Resin*, 100–200 mesh, chloride form.

94.2—

87.2 *Nitric Acid*—HNO<sub>3</sub> (sp gr 1.42).

94.3—

87.3 *Nitric Acid (1 + 1)*—Dilute HNO<sub>3</sub> (sp gr 1.42) with an equal volume of water.

94.4—

87.4 *Sulfuric Acid*—H<sub>2</sub>SO<sub>4</sub> (sp gr 1.84).

94.5—

87.5 *Hydrofluoric Acid*—HF (48 %).

94.6—

87.6 *Hydrochloric Acid*—HCl (sp gr 1.19).

94.7—

87.7 *Hydrochloric Acid, (3 M)*—Dilute 250 mL of hydrochloric acid (sp gr 1.19) to 1 L with water.

94.8—

87.8 *Hydrochloric Acid (0.33 M)*—Dilute 27.5 mL hydrochloric acid (sp gr 1.19) to 1 L with water.

94.9—

87.9 *Perchloric Acid*—HClO<sub>4</sub> (70–72 %).

94.10—

87.10 *Thorium*—1-[0-(3,6-disulfo-2-hydroxy-1-naphthylazo) Benzenearsonic Acid, Disodium Salt]—0.1 w/v, dissolve 1.0 g of Thorium reagent in 1000 mL of water.

94.11—

87.11 *Thorium Standard Stock Solution (10.00 g Th/L)*—Dissolve 23.7941 g of thorium nitrate Th(NO<sub>3</sub>)<sub>4</sub>·4H<sub>2</sub>O in water and dilute to 1 L in a volumetric flask.

94.12—

87.12 *Thorium Solution, Standard (500 µg Th/mL)*—Pipet 5.0 mL of thorium stock solution (10 g Th/L) into a 100-mL volumetric flask and dilute to volume with water. This solution should be prepared daily.

94.13—

87.13 *Thorium Solution, Standard (25 µg Th/mL)*—Pipet 5.0 mL of standard thorium solution (500 µg Th/mL) into a 100-mL volumetric flask and dilute to volume with 0.33 M HCl. This solution should be prepared daily.

95.—

### 88. Calibration

9588.1 Into five 25-mL volumetric flasks pipet 0, 1, 2, 3, and 4 mL of standard thorium solution (25 µg thorium/mL)

<sup>12</sup> Ascariite II and Drierite have been found to be acceptable

<sup>13</sup> Trademark for this application. They are, respectively, the trademarks of Arthur H. Thomas tetrafluoroethylene (TFE) fluorocarbon polymers, available from E.I. du Pont de Nemours and W. A. Hammond Drierite Companies, Co., Wilmington, DE 19898.

representing 0, 25, 50, 75, and 100 µg of thorium.

9588.2 Add 2.5 mL of 0.1 % thorin reagent to each 25-mL flask and dilute to volume with 0.33 *M* HCl.

9588.3 Measure the absorbance of the standard solutions and blank at 545 nm on a spectrophotometer.

9588.4 Plot the absorbances, corrected for the blank absorbance, against micrograms of thorium.

## 896. Procedure

896.1 *Ion-Exchange Column Preparation:*

896.1.1 Fill the column with water and place a glass-wool plug at the bottom of the column using a glass rod.

896.1.2 Transfer 8 g of AG1-X8 resin into the column and pull the resin to the bottom plus using a slight vacuum. Place another plug of glass wool on top of the resin.

NOTE 275—Do not allow the level of the water or acid solution to fall below the top of the glass wool, or air pockets that impede the flow of samples will form.

896.1.3 Condition the resin by passing 75 mL of HNO<sub>3</sub> (1 + 1) through the resin at the rate of 1 drop/s.

896.2 *Sample Treatment.*

896.2.1 Weigh about 1 g of sample to the nearest 5 mg into a 250-mL beaker.

896.2.2 Add 1 g of pure U<sub>3</sub>O<sub>8</sub> to a 250-mL beaker as a blank and treat it in the same way as the sample.

896.2.3 Add 15 mL of HNO<sub>3</sub> (sp gr 1.42), 2 mL of H<sub>2</sub>SO<sub>4</sub> (sp gr 1.84), and about 2 mL of HF (48 %).

896.2.4 Digest on low heat for 5 min, then raise the temperature and digest with a sulfuric acid reflux. Finally, evaporate to near dryness.

896.2.5 Cool and add 100 mL of HNO<sub>3</sub> (1 + 1), 2 to 3 boiling chips, and gently boil for 5 min. Allow to cool.

896.2.6 If the total thorium content is expected to exceed 5000 µg in the sample weight taken for analysis, dilute the solution from 896.2.5 with HNO<sub>3</sub> (1 + 1) in a 250-mL volumetric flask. Take an appropriate aliquot containing approximately 2000 µg of thorium. Take the same aliquot from the blank solution.

896.2.7 Take the solution from 896.2.5 or the aliquot from 896.2.6 and adjust the volume to approximately 100 mL with HNO<sub>3</sub> (1 + 1).

896.2.8 Transfer the sample and blank solutions to the prepared resin columns. Rinse the beaker with 5 mL of HNO<sub>3</sub> (1 + 1) and add it to the column. Rinse the column with an additional 5 mL of HNO<sub>3</sub> (1 + 1).

896.2.9 Allow the solutions to pass through the columns at the rate of 1 drop/s into 500-mL wide-mouth Erlenmeyer flasks.

896.2.10 When the solution reaches the top glass-wool plug, pass an additional 150 mL of HNO<sub>3</sub> (1 + 1) through each column.

896.2.11 Once the HNO<sub>3</sub> (1 + 1) rinse is complete, remove the Erlenmeyer flask and dispose of the contents. Rinse with water and replace the empty flask under the column.

896.2.12 Elute the thorium by passing 100 mL of 3 *M* HCl through the column at the rate of 1 drop/s.

896.2.13 Transfer the eluted sample to a 250-mL beaker. Add 5 mL of HNO<sub>3</sub> (sp gr 1.42), 5 mL of HClO<sub>4</sub>, and 2 to 3 boiling chips, and evaporate the solutions to near dryness. Cool to room temperature.

896.2.14 Add 20 mL of 0.33 *M* hydrochloric acid to each beaker and transfer the solution to 100-mL volumetric flasks. Wash the beaker with 0.33 *M* hydrochloric acid, add the washings to the flask, and dilute to volume with 0.33 *M* hydrochloric acid.

896.2.15 Transfer an aliquot to a 25-mL volumetric flask and an equal volume of blank solution to a separate 25-mL volumetric flask to carry through as a reagent blank.

896.2.16 Add 2.5 mL of 1 % thorin solution to each 25-mL volumetric flask and dilute to volume with 0.33 *M* HCl.

896.2.17 Measure the absorbance of the samples and blank against a water reference at 545 nm in a spectrophotometer and correct the absorbances of the samples for the blank.

## 970. Calculation

970.1 Using the calibration curve or a calculated factor, obtain the micrograms of thorium contained in the 25-mL flask (see 896.2.16).

970.2 Calculate the percentage of thorium concentration, *T*, in the sample as follows:

$$T = \frac{2.5 C}{W \times A \times B} \quad (19)$$

where:

*C* = thorium content in the 25-mL flask (896.2.16), µg,

*A* = volume of aliquot taken in 896.2.15, mL,

*B* = volume of aliquot taken in 896.2.6, mL, and

*W* = weight of sample taken, g.

970.3 Calculate the percentage of thorium concentration, *T<sub>u</sub>*, in the sample on a uranium basis as follows:

$$T_u = \frac{T \times 100}{U} \quad (20)$$

where:

$T$  = concentration of thorium calculated in 970.2, %, and

$U$  = uranium in the sample, %.

### 981. Precision and Bias

981.1 *Precision*—A relative standard deviation for this test method has been reported as 10 % (see 4.2).

981.2 *Bias*—For information on the bias of this test method see 4.2.

## CALCIUM, IRON, MAGNESIUM, MOLYBDENUM, TITANIUM, AND VANADIUM BY ATOMIC ABSORPTION SPECTROPHOTOMETRY

### 992. Scope

992.1 This test method is suitable for the determination of calcium, iron, magnesium, molybdenum, titanium, and vanadium in uranium-ore concentrates. The nominal determination ranges of the elements are given in Table 1. The range of concentrations measured can be varied considerably by appropriate dilution of the sample solution (12).

992.2 For simultaneous determination of metals by plasma emission spectroscopy refer to Test Methods C 761, Sections 251 to 270.

~~100.~~

### 93. Summary of Test Method

~~100.1 A~~

93.1 A portion of homogenized ore-concentrate sample is dissolved in nitric acid and any silica is removed by evaporation with hydrofluoric acid. The residue is fused with potassium bisulfate, redissolved in nitric acid, and diluted to standard volume.

~~100.2 The~~

93.2 The sample solution, together with a blank and a series of calibration standard solutions that all contain 10 g of potassium bisulfate and 50 mL of nitric acid/L are aspirated into a nitrous oxide-acetylene flame of an atomic absorption spectrophotometer. The absorbances due to the various elements are measured and the impurity concentrations in the samples are calculated from calibration curves.

~~100.3 The~~

93.3 The concentration of uranium in the sample solution being analyzed is less than 2 g/L and, at this concentration, it is not necessary to make a corresponding addition to the calibration standards.

~~100.4 In~~

93.4 In addition to providing a fusion medium to ensure complete dissolution of the ore concentrate, the potassium bisulfate acts as an ionization suppressor in the flame.

~~101.~~

### 94. Interferences

~~101.1~~ 94.1 Atomic absorption spectrophotometry is a specific analytical technique. However, because uranium-ore concentrates vary widely in both the nature and concentration of impurities, the performance of this test method should be checked in accordance with Section ~~104.~~

~~102.~~ 97.

### 95. Apparatus

~~102.1~~

95.1 *Atomic Absorption Spectrophotometer.*

**TABLE 1 Instrumental Conditions**

Element	Wavelength, nm	Flame	Determination Range in Solution Aspirated, µg/mL
Calcium	422.7	N <sub>2</sub> O/C <sub>2</sub> H <sub>2</sub>	0.02–2
Iron	248.3	N <sub>2</sub> O/C <sub>2</sub> H <sub>2</sub>	0.05–2
Magnesium	285.2	N <sub>2</sub> O/C <sub>2</sub> H <sub>2</sub>	0.05–2
Molybdenum	313.3	N <sub>2</sub> O/C <sub>2</sub> H <sub>2</sub>	0.2–2
Titanium	365.3	N <sub>2</sub> O/C <sub>2</sub> H <sub>2</sub>	0.2–2
Vanadium	318.4	N <sub>2</sub> O/C <sub>2</sub> H <sub>2</sub>	0.1–2

~~102.2–~~

~~95.2 Pressure-Reducing Valve~~, suitable for use with nitrous oxide.

~~102.3–~~

~~95.3 Platinum Dishes~~, (7.6-cm diameter).

~~103.–~~

## **96. Reagents**

~~103.1–~~

~~96.1 Nitric Acid~~ (1 + 1)—Add a volume of high-purity HNO<sub>3</sub> (sp gr 1.42) to an equal volume of water and mix.

~~103.2–~~

~~96.2 Hydrofluoric Acid~~ (48 %).

~~103.3~~~~96.3 Potassium Bisulfate~~ (KHSO<sub>4</sub>).

~~103.4–~~

~~96.4 Potassium Bisulfate-Nitric Acid Solution~~—Dissolve 20 ± 0.5 g of high-purity KHSO<sub>4</sub> in about 50 mL of water. Add 100 mL HNO<sub>3</sub> (sp gr 1.42), dilute to 1 L, and mix.

~~103.5–~~

~~96.5 Sulfuric Acid~~ (sp gr 1.84).

~~103.6–~~

~~96.6 Calcium Solution, Standard~~ (1 mg/mL)—Dissolve 1250 ± 2 mg of calcium carbonate (CaCO<sub>3</sub>), previously dried at 110°C for 1 h, in 50 mL of HNO<sub>3</sub> (1 + 1). Boil for 5 min, allow to cool, and dilute with water to 500 mL in a volumetric flask.

~~103.7–~~

~~96.7 Iron Solution, Standard~~ (1 mg/mL)—Dissolve 500 ± 1 mg of pure iron (Fe) in 50 mL of HNO<sub>3</sub> (1 + 1). Cool and dilute with water to 500 mL in a volumetric flask.

~~103.8–~~

~~96.8 Magnesium Solution, Standard~~ (1 mg/mL)—Dissolve 500 ± 1 mg of pure magnesium (Mg) in 50 mL of HNO<sub>3</sub> (1 + 1). Cool and dilute to 500 mL in a volumetric flask.

~~103.9–~~

~~96.9 Molybdenum Solution, Standard~~ (1 mg/mL)—Dissolve 750 ± 1 mg of molybdenum trioxide (MoO<sub>3</sub>), previously dried at 350°C for 2 h, in 25 mL of ammonia solution (sp gr 0.88) and 100 mL of water. Boil to remove excess ammonia. Cool and dilute to 500 mL in a volumetric flask.

~~103.10–~~

~~96.10 Titanium Solution, Standard~~ (1 mg/mL)—Dissolve 834 ± 1 mg of titanium dioxide (TiO<sub>2</sub>) in 10 mL of sulfuric acid (sp gr 1.84) and 0.8 g of ammonium sulfate ((NH<sub>4</sub>)<sub>2</sub>SO<sub>4</sub>). Heat until the TiO<sub>2</sub> dissolves and allow the solution to cool to room temperature. Dilute to 500 mL with water in a volumetric flask.

~~103.11–~~

~~96.11 Vanadium Solution, Standard~~ (1 mg/mL)—Dissolve 1148 ± 2 mg of ammonium metavanadate NH<sub>4</sub>VO<sub>3</sub>, previously dried at 120°C for 1 h, in 50 mL of HNO<sub>3</sub> (1 + 1). Heat to assist dissolution. Cool and dilute to 500 mL in a volumetric flask.

~~103.12–~~

~~96.12 General Metals Solution, Standard Combined~~ (100 µg/mL)—Pipet 100 mL of each standard solution (1 mg/mL) of aluminum, calcium, iron, magnesium, molybdenum, vanadium, and zinc into a 1-L volumetric flask. Dilute to volume with water and mix.

~~103.13–~~

~~96.13 General Metals Solution, Standard Combined~~ (10 µg/mL)—Pipet 10 mL of the combined standard (100 µg/mL) into a 100-mL standard flask. Add 5 mL of nitric acid (sp gr 1.42) and dilute to volume with water.

~~104.–~~

## **97. Check on Method Performance**

~~104~~~~97.1~~ Whenever a new type of ore concentrate is analyzed, the performance of the method shall be checked by measuring the recovery of known concentrations of added impurities.

~~104~~~~97.2~~ Dissolve two separate 1.000 ± 0.005-g portions of the same homogenized sample following the procedure detailed in ~~106.1–106.4, 99.1–99.4~~, but adding 5.0 mL of combined general-metal standard solution (100 µg/mL) to one of the two samples before dissolution.

~~104~~~~97.3~~ Measure the absorbances of the two solutions for the elements of interest using the conditions employed in ~~106.5–99.5~~ and ~~106.6~~.

~~104.4~~ ~~Obtain~~ ~~99.6~~.

~~97.4~~ ~~Obtain~~ the micrograms of metal per millilitre for each of the two solutions from the calibration curves and calculate the percentage recovery of the added elements.

~~105.~~

## **98. Calibration**

### ~~105.1~~ Into

98.1 Into a series of six 500-mL volumetric flasks, add by pipet 0, 5, 10, and 25 mL of combined general-metals standard (10 µg/mL) and 5 and 10 mL of combined general-metals standard (100 µg/mL).

### ~~105.2~~ To

98.2 To each flask, add 250 mL of potassium bisulfate-nitric acid solution and dilute to volume with water. The six flasks contain respectively 0, 0.1, 0.2, 0.5, 1, and 2 µg/mL of each of the metals of interest. If these solutions are to be stored, they should be transferred to polyethylene bottles.

~~105~~98.3 Aspirate the standards and blank under the same instrumental conditions as used for the sample (see ~~106.5~~ 99.5 and ~~106.6~~).

~~106.~~ 99.6.

## **99. Procedure**

~~106~~99.1 Dissolve  $1.000 \pm 0.005$  g of homogenized sample in 10 mL of HNO<sub>3</sub> (sp gr 1.42) in a platinum dish. Add 10 mL HNO<sub>3</sub> (sp gr 1.42) to a second platinum dish as a blank and treat it in the same way as a sample.

### ~~106.2~~ Add

99.2 Add 2 mL of HF (48 %) and evaporate the solution to dryness. Add  $5 \pm 0.05$  g KHSO<sub>4</sub> to the residues and heat gently over a burner increasing the temperature gradually until a clear melt is obtained.

~~106~~99.3 Allow the dish and contents to cool. Add 25 mL of HNO<sub>3</sub> (sp gr 1.42) and about 20 mL water. Heat gently until dissolution is complete.

~~106~~99.4 Allow the solution to cool and transfer it to a 500-mL volumetric flask washing the dish with two 20-mL volumes of water. Dilute to 500 mL with water and mix.

### ~~106.5~~ Set

99.5 Set up the atomic-absorption spectrophotometer in accordance with to the manufacturer's instructions using a nitrous oxide-acetylene flame and the relevant conditions given in Table 1.

NOTE 286—The burner head is aligned parallel to the light path except for the determination of magnesium when it is set at an angle of 45°.

~~106~~99.6 Following the manufacturer's operating instructions, obtain absorbance readings for the impurity elements of interest in the sample and corresponding blank, and for the calibration standards as described in Section ~~105~~.

### ~~106.7~~ Correct 98.

99.7 Correct the absorbances of the calibration standards for the calibration blank and construct calibration curves by plotting corrected absorbance against micrograms of element per millilitre.

~~106~~99.8 Correct the absorbance of the impurity elements in the sample for the reagent blank and obtain their concentration in micrograms per millilitre from the appropriate calibration curves.

### ~~106.9~~ If

99.9 If the absorbance of the sample is greater than that of the highest calibration standard, pipet a 10-mL aliquot of the sample and the blank solution prepared in ~~106.4~~ 99.4 into 100-mL volumetric flasks. Add 45 mL of potassium bisulfate-nitric acid solution and dilute to volume with water. Repeat the procedure detailed in ~~106.6~~ ~~106.8~~.

~~107.~~ 99.6-99.8.

## **100. Calculation**

~~107~~0.1 Calculate the percentage of impurity element concentration,  $E$ , in the sample as follows:

$$E = \frac{C \times D \times 0.05}{W} \quad (21)$$

where:

$C$  = concentration of element in the solution aspirated, µg/mL,

$D$  = dilution factor (10) if applicable (see ~~106.9~~, 99.9), and

$W$  = weight of sample taken, g.

~~107~~0.2 Calculate the percentage of impurity element concentration,  $E_u$ , on a uranium basis as follows:

$$E_u = \frac{C \times D \times 5}{W \times U} \quad (22)$$

where:

$C$  = concentration of element in the solution aspirated, µg/mL,

$D$  = dilution factor (10) if applicable (see ~~106.9~~, 99.9),

$W$  = weight of sample taken, g, and  
 $U$  = uranium in original sample, %.

### **1081. Precision and Bias**

1081.1 *Precision*—The relative standard deviation, based on 74 determinations at various impurity levels in a range of different ore concentrates, varies between 5 and 10 % (see 4.2).

1081.2 *Bias*—For information about the bias of this test method see 4.2.

## **POTASSIUM AND SODIUM BY ATOMIC ABSORPTION SPECTROPHOTOMETRY**

### **1092. Scope**

1092.1 This test method is suitable for the determination of sodium and potassium in uranium-ore concentrates in the range from 0.05 to 10 % on a uranium basis.

### **1103. Summary of Test Method**

1103.1 A portion of the sample is dissolved in nitric acid. The silica is volatilized or solubilized by evaporation with hydrofluoric acid. Cesium is added as an ionization suppressant and the solution is diluted to contain 0.1 % sample, 0.05 % cesium, and 5 % nitric acid.

1103.2 The prepared sample solutions, together with standard calibration solutions, are aspirated into an air-acetylene flame of an atomic-absorption spectrophotometer. The absorbance readings of the samples are compared to those of the standard solutions. Because the uranium concentration in the sample solutions is below the level required to produce nonspecific absorption, the standards do not need to be prepared in a uranium-based matrix solution.

~~111.~~

### **104. Interferences**

1104.1 Because of the variation in the nature and concentration of impurities in uranium-ore concentrates, a check must be kept on the potential interference in the atomic absorption flame process by following the procedure in Section ~~114~~.

~~112. 107.~~

### **105. Apparatus**

~~112.1~~

105.1 *Atomic Absorption Spectrophotometer.*

~~112.2~~

105.2 *Platinum Dishes (7.6-cm diameter).*

~~113.~~

### **106. Reagents**

~~113.1~~

106.1 *Nitric Acid (1 + 1)*—Add a volume of  $\text{HNO}_3$  (sp gr 1.42) to an equal volume of deionized water and mix.

~~113.2~~

106.2 *Hydrofluoric Acid (48 %).*

~~113.3~~

106.3 *Cesium Solution, Stock (1 %)*—Dissolve  $14.66 \pm 0.05$  g of anhydrous cesium nitrate ( $\text{CsNO}_3$ ) in 20 mL  $\text{HNO}_3$  (1 + 1) and 200 mL of water. Dilute to 1 L with water.

~~113.4~~

106.4 *Cesium Solution (0.1 %)*—Add 100 mL  $\text{HNO}_3$  (sp gr 1.42) to 100 mL cesium solution (1 %) and dilute to 1 L with water.

~~113.5~~

106.5 *Sodium Solution, Standard (1 g/L)*—Dry some anhydrous sodium nitrate ( $\text{NaNO}_3$ ) at  $140^\circ\text{C}$  for 1 h. Dissolve 1.848 g of dried  $\text{NaNO}_3$  in 50 mL  $\text{HNO}_3$  (1 + 1) and dilute to 500 mL with water in a volumetric flask.

~~113.6~~

106.6 *Potassium Solution, Standard (1 g/L)*—Dry some anhydrous potassium nitrate ( $\text{KNO}_3$ ) at  $140^\circ\text{C}$  for 1 h. Dissolve 1.293 g of dried  $\text{KNO}_3$  in 50 mL  $\text{HNO}_3$  (1 + 1) and dilute to 500 mL with water in a volumetric flask.

~~113.7~~

106.7 *Sodium-Potassium Solution, Standard (100  $\mu\text{g/mL}$ )*—Pipet 10 mL of sodium solution (1 g/L) and 10 mL of potassium solution (1 g/L) into a 100-mL volumetric flask and dilute to volume with water.

~~113.8~~

~~106.8~~ *Sodium-Potassium Solution, Standard* (10 µg/mL)—Pipet 10 mL of sodium-potassium solution (100 µg/mL) into a 100-mL volumetric flask and dilute to volume with water.

~~113.9~~

~~106.9~~ *Sodium-Potassium Solution, Standard* (1 µg/mL)—Pipet 10 mL of sodium-potassium solution (10 µg/mL) into a 100-mL volumetric flask and dilute to volume with water.

~~114.~~

### **107. Check on Method Performance**

~~11407.1~~ In order to confirm the satisfactory operation of the test method, prepare duplicate weights of an ore-concentrate sample for analysis following the procedure in ~~116.1-116.6~~, 109.1-109.6, but adding 2.0 mL of sodium-potassium solution (100 µg/mL) to one portion of sample before dissolution.

~~11407.2~~ Calculate the percentage recovery of the added sodium-potassium standard.

~~115.~~

### **108. Calibration**

~~11508.1~~ Pipet appropriate volumes of the 1, 10, and 100- µg/mL sodium-potassium standard solutions into 100-mL volumetric flasks containing 50 mL of cesium solution (0.1 %) to give a range of standards containing 0, 0.2, 0.5, 1.0, 2.0, 5.0, and 10 µg/mL of sodium and potassium when diluted to volume. Transfer to polyethylene bottles.

~~11508.2~~ Aspirate the standards into the air-acetylene flame under the same conditions as those used for the samples (see ~~116.6~~ 109.6) and record the absorbance for both sodium and potassium.

~~11508.3~~ Correct the absorbances for the blank and plot micrograms of sodium per millilitre and micrograms of potassium per millilitre against corrected absorbances.

~~116.~~

### **109. Procedure**

~~11609.1~~ Weigh  $0.100 \pm 0.001$  g of homogenized sample into a platinum dish, and add 5 mL of NO<sub>3</sub> (sp gr 1.42) and 2 mL of HF (48 %). Add the same volume of acids to a second platinum dish in order to determine the reagent blank and process this in the same way as the sample.

~~11609.2~~ Heat both platinum dishes and evaporate the solutions to dryness. Allow the dishes to cool, add 5 mL of water and 2 mL of HNO<sub>3</sub> (1 + 1), and evaporate to near dryness. Add 20 mL of water and heat to redissolve.

~~11609.3~~ Allow the solutions to cool, then transfer them to 100-mL polypropylene volumetric flasks, rinsing the dishes with water. Add 50 mL of cesium solution (0.1 %), dilute to volume with water, mix, and transfer to a polyethylene bottle. The solution now contains sample (0.1 %), cesium (0.05 %), and HNO<sub>3</sub> (5 %).

~~11609.4~~ Pipet 5 mL of the 0.1 % sample solution into a volumetric flask, add 22.5 mL of cesium solution (0.1 %), and dilute to 50 mL with water. This solution contains sample (0.01 %), cesium (0.05 %), and HNO<sub>3</sub> (5 %). Dilute a 5-mL aliquot of the blank solution following exactly the same procedure. Transfer the prepared solutions to polyethylene bottles.

~~11609.5~~ Set up the atomic absorption spectrophotometer in accordance with the manufacturer's instructions for determining sodium and potassium using an air-acetylene flame and wavelength settings of 589.0 nm for sodium and 766.5 nm for potassium.

~~11609.6~~ Aspirate the sample and blank solutions and the calibration standards into the flame and record the absorbances at both wavelengths. If the absorbance value for the sample exceed that of the 10-µg/mL calibration standard solution, nebulize the diluted sample and blank prepared in ~~11609.4~~.

### **1170. Calculation**

~~1170.1~~ Correct the absorbances of the samples for the reagent blank and, from the calibration curves, obtain the micrograms of sodium per millilitre and micrograms of potassium per millilitre.

~~1170.2~~ When the 0.1 % sample solution is nebulized (see 117.4), calculate the percentage of sodium and potassium concentrations,  $S_u$  or  $P_u$  respectively, on a uranium basis as follows:

$$S_u \text{ or } P_u = \frac{C \times 10}{U} \quad (23)$$

where:

$C$  = sodium or potassium, µg/mL, and

$U$  = uranium in the sample, %.

~~1170.3~~ When the 0.01 % sample solution is nebulized (see 117.5), calculate the percentage of sodium and potassium concentrations using the same equation in ~~1170.2~~.

### **1181. Precision and Bias**

~~1181.1~~ *Precision*—The relative standard deviations, measured at varying levels and on a variety of different ore concentrates,

has been reported as sodium 9.5 % and potassium 8.0 % (see 4.2).

~~1181.2~~ *Bias*—For information on the bias of this test method see 4.2.

## **BORON BY SPECTROPHOTOMETRY**

### **1192. Scope**

1192.1 This test method covers the determination of boron in uranium-ore concentrates when present in concentrations of more than 0.001 % by weight (10 µg/g).

~~120.~~

### **113. Summary of Test Method**

~~12013.1~~ The sample of ore concentrate is dissolved in 12 M HCl, with the addition of HNO<sub>3</sub> if necessary. An aliquot is treated with HCl and H<sub>2</sub>SO<sub>4</sub> and fumed. The resulting solution is diluted and an aliquot is mixed with concentrated H<sub>2</sub>SO<sub>4</sub> and carminic acid (C<sub>22</sub>H<sub>20</sub>O<sub>13</sub>) to form the bluish-red carmine-boron complex. This solution is measured spectrophotometrically at 610 nm (13).

### **1214. Interferences**

1214.1 Nitrate ion is removed by fuming with H<sub>2</sub>SO<sub>4</sub>.

1214.2 Vanadium is reduced to the tetravalent state; in this form it does not interfere.

1214.3 Titanium and zirconium do not interfere at levels normally found in uranium-ore concentrate (below 0.10 % titanium and 5 % zirconium).

1214.4 Uranium forms a carmine-uranium complex which has an absorbance at 610 nm. This interference can be corrected for by running a uranium blank. Each gram of uranium in the sample produces an interference equivalent to approximately 5 µg of boron.

1214.5 Fluoride ion can cause loss of boron by volatilization during the H<sub>2</sub>SO<sub>4</sub> fuming stage.

~~122.~~

### **115. Apparatus**

~~122.1~~

115.1 *Spectrophotometer*, with 1-cm cells in accordance with Practice E 60.

~~122.2~~

115.2 *Platinum Dishes*, 50-mL.

~~122.3~~

115.3 *Micropipet*, 100-µL.

~~122.4~~

115.4 *TFE-Fluorocarbon Beakers and Covers*, 250-mL.

~~122.5~~

115.5 *Plastic Volumetric Flasks*, 25 and 50-mL.

~~122.6~~

115.6 *Plastic Pipets*, 25-mL.

~~123.~~

### **116. Reagents**

~~123.1~~

116.1 *Hydrochloric Acid* (HCl) (sp gr 1.19).

~~123.2~~

116.2 *Nitric Acid* (HNO<sub>3</sub>) (sp gr 1.42).

~~123.3~~

116.3 *Sulfuric Acid* (H<sub>2</sub>SO<sub>4</sub>) (sp gr 1.84).

~~123.4~~

116.4 *Sulfuric Acid* (9 M)—Carefully add, while stirring, 500 mL sulfuric acid (H<sub>2</sub>SO<sub>4</sub>) (sp gr 1.84) to 500 mL of distilled water, mix, cool, and dilute to 1 L.

~~123.5~~

116.5 *Carminic Acid Solution* (0.25 g/L)—Dissolve 0.250 g of carminic acid (1,3,4-(HO)<sub>3</sub>-2CO(CHOH)<sub>4</sub>CH<sub>3</sub>-C<sub>6</sub>H<sub>5</sub>-COOH-6-OH-8-CH<sub>3</sub>CO) in 1 L of sulfuric acid (H<sub>2</sub>SO<sub>4</sub>) (sp gr 1.84). Store in a plastic container and keep closed.

~~123.6~~

116.6 *Boron Solution, Standard* (100 µg/mL)—Dissolve 0.5716 g of boric acid (H<sub>3</sub>BO<sub>3</sub>), previously dried at 110°C, in distilled water and dilute to 1 L.

~~123.7–~~

~~116.7 Sodium Carbonate~~ ( $\text{Na}_2\text{CO}_3$ ), boron-free.

~~123.8–~~

~~116.8 Uranium Solution, Standard~~ (100 g/L)—Dissolve 11.79 g of high-purity  $\text{U}_3\text{O}_8$  (<1  $\mu\text{g}$  boron/g) in  $\text{HNO}_3$  (1 + 1) and dilute to 100 mL with water.

~~124.–~~

### **117. Calibration**

~~12417.1~~ Prepare a series of standards by pipetting 2, 4, 6, 8, and 10 mL of the standard boron solution (100  $\mu\text{g}$  of boron/mL) into 100-mL plastic volumetric flasks. Distilled water is used as a blank.

~~12417.2~~ Dilute standards to volume with distilled water and mix.

~~12417.3~~ Follow ~~12518.9–12518.11~~ of the procedure.

~~12417.4~~ Prepare a calibration curve by plotting micrograms of boron in the standards against the corresponding absorbance.

~~125.–~~

### **118. Procedure**

~~12518.1~~ Weigh a uranium-ore concentrate sample of up to 5 g ( $\pm 0.001$  g) into a 250-mL TFE-fluorocarbon beaker. Carry a reagent blank throughout the procedure.

~~NOTE 297~~—The sample should contain 100 to 500  $\mu\text{g}$  of boron.

~~12518.2~~ Wet the sample with 5 mL of distilled water and add 20 mL of HCl (sp gr 1.19).

~~12518.3~~ Cover the TFE-fluorocarbon beaker and heat the sample gently until it dissolves.

~~NOTE 30~~—~~Add 28~~—Add 0.5 mL  $\text{HNO}_3$  (sp gr 1.42) or more to complete the sample dissolution if necessary.

~~12518.4~~ Cool the sample solution and transfer to a 50-mL plastic volumetric flask. Dilute to volume with distilled water and mix.

~~NOTE 31~~—~~If 29~~—If the solution is cloudy, filter or centrifuge before diluting to volume and fuse the residue with 2 to 4 g  $\text{Na}_2\text{CO}_3$ . Dissolve the fusion with HCl (sp gr 1.19) and add the solution to the 50-mL plastic volumetric flask containing the sample.

~~12518.5~~ Transfer 25 mL of the sample solution using a plastic pipet into a 250-mL TFE-fluorocarbon baker.

~~12518.6~~ Add 5 mL of HCl (sp gr 1.19) and 10 mL of 9 M  $\text{H}_2\text{SO}_4$ . Heat the solution until the sample just begins to fume.

~~NOTE 320~~—Excessive fuming may volatilize boron; therefore, control of the fuming step is critical.

~~12518.7~~ Cool and transfer the solution into a 25-mL plastic volumetric flask with distilled water. Dilute to volume with water and mix.

~~12518.8~~ Using a micropipet, transfer a 1-mL aliquot into a dry 50-mL plastic vial.

~~12518.9~~ Add 5 mL  $\text{H}_2\text{SO}_4$  (sp gr 1.84) and 5 mL of carminic acid solution. Immediately cap the vial and mix.

~~NOTE 331~~—The solution must be capped immediately since sulfuric acid tends to pick up water which adversely affects the condensation reaction resulting in incomplete color development.

~~12518.10~~ After 30 min, measure the absorbance at 610 nm in a 1-cm cell using a reagent blank as a reference.

~~12518.11~~ Using either the calibration curve (see ~~124.4~~ ~~117.4~~) or a calibration factor, obtain the boron content in micrograms for the 1-mL aliquot (see ~~125.8~~).

~~126.– 118.8).~~

### **119. Determination of Uranium Blank**

~~12619.1~~ Pipet 5, 10, and 20-mL aliquots of the standard uranium solution into separate 250-mL TFE-fluorocarbon beakers. These aliquots are equivalent to 1, 2, and 4 g of uranium in the sample.

~~12619.2~~ Carry through the procedure in ~~12518.6–12518.11~~.

~~12619.3~~ Plot apparent boron content against grams of uranium and calculate the slope in micrograms of boron per gram of uranium and use this for the blank correction in ~~1270.2~~.

### **1270. Calculation**

~~1270.1~~ Calculate the concentration of boron,  $B_u$ , on a uranium basis (uncorrected) as follows:

$$B_u = \frac{50 C \times 100}{W \times U} \quad (24)$$

where:

$C$  = boron in the 1-mL aliquot, mg,  
 $W$  = weight of sample, g, and  
 $U$  = uranium in the sample, %.

1270.2 Calculate the percentage of boron  $B_c$  on a uranium basis as follows; correcting for the apparent boron due to uranium interference:

$$B_c = (B_u - D)10^{-4} \quad (25)$$

where:

$B_u$  = boron per gram of uranium,  $\mu\text{g}$ , and  
 $D$  = uranium blank calculated in 126.3, 119.3.

### 1281. Precision and Bias

1281.1 *Precision*—A relative standard deviation has been reported as 5 % at 0.005 % boron level and 2 % at 0.040 % boron level (see 4.2).

1281.2 *Bias*—based on spiked samples show 94 to 106 % recoveries (see 4.2).

### 1292. Keywords

1292.1 concentrates; uranium ore

## REFERENCES

- (1) Davies, W., and Gray, W., "A Rapid and Specific Titrimetric Method for the Precise Determination of Uranium Using Iron (II) Sulfate as Reductant," *Talanta*, Vol 11, 1964, p. 1203.
- (2) New Brunswick Laboratory, "Annual Progress Report for Period July 1968–June 1968," *USAEC Document NBL-247*, Atomic Energy Commission Research and Development Report, 1969, pp. 1–14.
- (3) Eberle, A. R., Lerner, M. W., Goldbeck, C. G., and Rodden, C. J., "Titrimetric Determination of Uranium in Product, Fuel, and Scrap Materials After Ferrous Ion Reduction in Phosphoric Acid," *USAEC Document NBL-252*, Atomic Energy Commission Research and Development Report, 1970.
- (4) New Brunswick Laboratory "Annual Progress Report for Period July 1969–June 1970," *USAEC Document NBL-267*, Atomic Energy Commission Research and Development Report, 1971, p. 26.
- (5) New Brunswick Laboratory "Annual Progress Report for Period July 1972–June 1973," *USAEC Document NBL-267*, Atomic Energy Commission Research and Development Report, 1973, pp. 6, 13, 19.
- (6) Furman, N. H., (Editor), *Scott's Standard Methods of Chemical Analysis*, Joseph D. Van Nostrand Co., Inc., 1962, Vol 1, pp. 298–299.
- (7) De Boer, J. H., "The Determination of Fluoride in Uranium Oxide," *Chemisch Weekblad*, Vol 21, 1924, p. 404.
- (8) Lamar, W. L., and Seigmiller, E. G., *Industrial and Engineering Chemistry, Analytical Edition*, Vol 13, 1941, p. 901.
- (9) Powell, R. H., and Menis, O., *Analytical Chemistry*, Vol 30, 1958, p. 1546.
- (10) Snell, F. D., and Snell, C. T., "Colorimetric Methods of Analysis," Vol IIA, Joseph D. Van Nostrand Co., 1959, pp. 561–562.
- (11) Elwell, W. T., and Wilson, H. N., "The Colorimetric Determination of Phosphorus in Steel and Copper—Base Alloys," *Analyst*, Vol 81, 1956, pp. 136–143.
- (12) Scarborough, J. M., "Determination by Atomic Absorption of Molybdenum, Ruthenium, Palladium, and Rhodium in Uranium Alloys," *Analytical Chemistry*, Vol 41, 1969, p. 250.
- (13) Day, G. T., and Dunlop, G. A., "Development of an Analytical Method to Determine Boron in Yellowcake and Related Materials," *Eldorado Nuclear Ltd., Report AR82-2*, 1981.

*ASTM International takes no position respecting the validity of any patent rights asserted in connection with any item mentioned in this standard. Users of this standard are expressly advised that determination of the validity of any such patent rights, and the risk of infringement of such rights, are entirely their own responsibility.*

*This standard is subject to revision at any time by the responsible technical committee and must be reviewed every five years and if not revised, either reapproved or withdrawn. Your comments are invited either for revision of this standard or for additional standards and should be addressed to ASTM International Headquarters. Your comments will receive careful consideration at a meeting of the responsible technical committee, which you may attend. If you feel that your comments have not received a fair hearing you should make your views known to the ASTM Committee on Standards, at the address shown below.*

*This standard is copyrighted by ASTM International, 100 Barr Harbor Drive, PO Box C700, West Conshohocken, PA 19428-2959, United States. Individual reprints (single or multiple copies) of this standard may be obtained by contacting ASTM at the above address or at 610-832-9585 (phone), 610-832-9555 (fax), or service@astm.org (e-mail); or through the ASTM website (www.astm.org).*