



Designation: C 1133 – 9603

## Standard Test Method for Nondestructive Assay of Special Nuclear Material in Low-Density Scrap and Waste by Segmented Passive Gamma-Ray Scanning<sup>1</sup>

This standard is issued under the fixed designation C 1133; the number immediately following the designation indicates the year of original adoption or, in the case of revision, the year of last revision. A number in parentheses indicates the year of last reapproval. A superscript epsilon ( $\epsilon$ ) indicates an editorial change since the last revision or reapproval.

### 1. Scope

1.1 This test method covers the transmission-corrected nondestructive assay (NDA) of gamma-ray emitting special nuclear materials (SNMs), most commonly  $^{235}\text{U}$ ,  $^{239}\text{Pu}$ , and  $^{241}\text{Am}$ , in low-density scrap or waste, packaged in cylindrical containers. The method can also be applied to NDA of other gamma-emitting nuclides including fission products. High-resolution gamma-ray spectroscopy is used to detect and measure the nuclides of interest and to measure and correct for gamma-ray attenuation in  $\pi$  a series of horizontal segments (collimated gamma detector views) of the container. Corrections are also made for counting losses

<sup>1</sup> This test method is under the jurisdiction of ASTM Committee C-26 on Nuclear Fuel Cycle and is the direct responsibility of Subcommittee C26.10 on Nondestructive Assay.

Current edition approved July 10, ~~1996~~ 2003. Published September 2003. Originally approved in 1996. Last previous edition approved in 1996 as C 1133 – 96.

occasioned by signal processing limitations (1–3).<sup>2</sup>

1.2 There are currently at least three several systems in use or under active development for determining the attenuation experienced by the radiation emitted from the nuclide of interest. These methods include the following: the original segmented gamma scan transmission procedure (SGS) (4,5); a procedure involving measurements of the transmission at multiple energies combined with corrections for nuclide lumps based on assays NDA of the nuclide of interest at multiple energies (MESGS) radioisotopic materials (6–8); and (4-8). A related technique, tomographic gamma-ray scanning procedures (TGSS) (TGS), is not included in this test method (9,10).

1.2.1 The simplest procedure;

1.2.1 This test method will cover two implementations of the Segmented Gamma Scanning (SGS) procedure: (1) Isotope Specific (Mass) Calibration, the original segmented gamma scan transmission SGS procedure, uses standards of known radionuclide masses to determine detector response in a mass versus corrected count rate calibration that applies only to those specific radionuclides for which it is calibrated, and (2) Efficiency Curve Calibration, an alternative method, typically uses non-SNM radionuclide sources to determine system detection efficiency vs. gamma energy and thereby calibrate for all gamma-emitting radionuclides of interest (11). These two methods will be covered in detail in the remainder of the main body of this test method and Annex A1.

1.2.21.1 ~~Efficiency Curve Calibration~~, over the limited experience and literature documenting energy range for which the MESGS and TGS procedures, discussion in this test method will be limited to efficiency is defined, has the above references.

1.3 Two conditions must be met to optimize SGS assay results as follows:

1.3.1 The particles containing the nuclides advantage of interest must be small to minimize self absorption of emitted providing calibration for many gamma-emitting nuclide for which half-life and gamma radiation.

1.3.2 The mixture of material within each item segment must be sufficiently uniform to apply an attenuation correction factor, computed from a measurement of gamma-ray transmission through the segment.

1.4 The emission intensity data are available.

1.3 The assay technique may be applicable to loadings of from one up to several hundred grams of nuclide in a 208-L (55-gal) drum, with more restricted ranges to be applicable depending on specific packaging and counting equipment considerations.

1.4 Measured transmission values must be available to permit valid for use in calculation of segment-specific attenuation corrections at the energies of analysis.

1.5 A related method, SGS with calculated correction factors based on sample content and density, is not included in this standard.

1.6 The values stated in SI units are to be regarded as the standard. The values given in parentheses are for information only.

1.67 *This standard does not purport to address all of the safety concerns, if any, associated with its use. It is the responsibility of the user of this standard to establish appropriate safety and health practices and determine the applicability of regulatory limitations prior to use.* Specific precautionary statements are given in Section 8.

## 2. Referenced Documents

### 2.1 ASTM Standards:

C 982 Guide for Selecting Components for Energy-Dispersive X-Ray Fluorescence (XRF) Systems<sup>3</sup>

C 1030 Test Method for Determination of Plutonium Isotopic Composition by Gamma Ray Spectrometry<sup>3</sup>

C 1128 Guide for Preparation of Working Reference Materials for Use in the Analysis of Nuclear Fuel Cycle Materials<sup>3</sup>

C 1156 Guide for Establishing Calibration for a Measurement Method Used to Analyze Nuclear Fuel Cycle Materials<sup>3</sup>

C 1207 Test Method for Nondestructive Assay of Plutonium in Scrap and Waste by Passive Neutron Coincidence Counting<sup>3</sup>

C 1210 Guide for Establishing a Measurement System Quality Control Program for Analytical Chemistry Laboratories within the Nuclear Industry<sup>3</sup>

C 1458 Test Method for Nondestructive Assay of Plutonium, Tritium and <sup>241</sup>Am by Calorimetric Assay<sup>3</sup>

E 181 Test Methods for Detector Calibration and Analysis of Radionuclides<sup>4</sup>

### 2.2 ANSI Standards:<sup>5</sup>

ANSI N15.20 Guide to Calibrating Nondestructive Assay Systems

ANSI N15.35 Guide to Preparing Calibration Material for Nondestructive Assay Systems that Count Passive Gamma Rays

ANSI N15.37 Guide to the Automation of Nondestructive Assay Systems for Nuclear Materials Control

ANSI/IEEE 325 Test Procedures for Germanium Gamma-Ray Detectors

ANSI/IEEE 645 Test Procedures for High-Purity

ANSI N42.14 Calibration and Use of Germanium Detectors Spectrometers for Ionizing Radiation the Measurement of Gamma-Ray Emission Rates of Radionuclides

<sup>2</sup> The boldface numbers in parentheses refer to the list of references at the end of this test method.

<sup>3</sup> Annual Book of ASTM Standards, Vol 12.01.

<sup>4</sup> Annual Book of ASTM Standards, Vol 12.02.

<sup>5</sup> Available from American National Standards Institute (ANSI), 25 W. 42nd 43rd St., 43th 4th Floor, New York, NY 10036.

2.3 NRC Regulatory Guides:<sup>6</sup>

Regulatory Guide 5.9, Rev. 2, Guidelines for Germanium Spectroscopy Systems for Measurement of Special Nuclear Materials  
 Regulatory Guide 5.11, Rev. 1, Nondestructive Assay of Special Nuclear Material Contained in Scrap and Waste  
 Regulatory Guide 5.53, Rev. 1, Qualification, Calibration, and Error Estimation Methods for Nondestructive Assay

**3. Summary of Test Method**

3.1 The assay of the nuclides of interest is accomplished by measuring the intensity of a one or more characteristic gamma rays from each nuclide. Corrections are made for count rate-related losses and attenuation by the item. ~~Comparison to similarly corrected gamma-ray intensities, observed during the measurement of~~ The appropriate mass or efficiency calibration materials, then provides the relationship between observed gamma-ray intensity and nuclide content.

3.2 Either of two distinct calibration methods can be used:

3.2.1 Isotope Specific Calibration provides assay results for only those radionuclides for which the SGS is specifically calibrated. Calibration is performed using standards containing the radionuclides to be assayed.

3.2.2 Efficiency Curve Calibration entails determination of the system detecton efficiency as a function of gamma ray energy. Analysis of assay data consists of using the energy of a peak to infer the emitting radionuclide, and then calculating the radionuclide mass from the specific activity and the gamma emission intensity of the radionuclide, and the corrected count rate and detector efficiency at the peak energy.

3.3 The assay item is rotated about its vertical axis and scanned segment by segment along that axis, thereby reducing the effects of nonuniformity in both matrix density and nuclide distribution (see Fig. 1).

3.3.4 Count rate-dependent losses from pulse pile-up and analyzer dead time are ~~monitored and~~ corrected for by electronic modules, and radioactive source, a pulser, or a combination of these.

3.4.5 The average linear attenuation coefficient of each ~~vertical~~ horizontal segment is calculated by measurement of the transmitted intensity of an appropriate external gamma-ray source. The source is mounted directly opposite the gamma-ray detector, on the far side of the assay item (see Fig. 1).

3.5 The corrected gamma-ray count rates for

3.6 Two conditions must be met to optimize SGS assay results as follows:

3.6.1 The particles containing the nuclides of interest are determined on a segment-by-segment basis. The precision must be small enough to minimize self-absorption of the measured count rate of each emitted gamma ray used for analysis is also estimated on a segment-by-segment basis. At the completion radiation (12).

3.6.1.1 Under specific conditions, particles large enough to provide significant self absorption (lumps ) may be assayed accurately. These conditions include use of the measurement of all segments, count rates are summed, specific Nuclide differential

<sup>6</sup> Available from U.S. Nuclear Regulatory Commission, Public Document Room, 1717 H St., N.W., Washington, DC 20555.

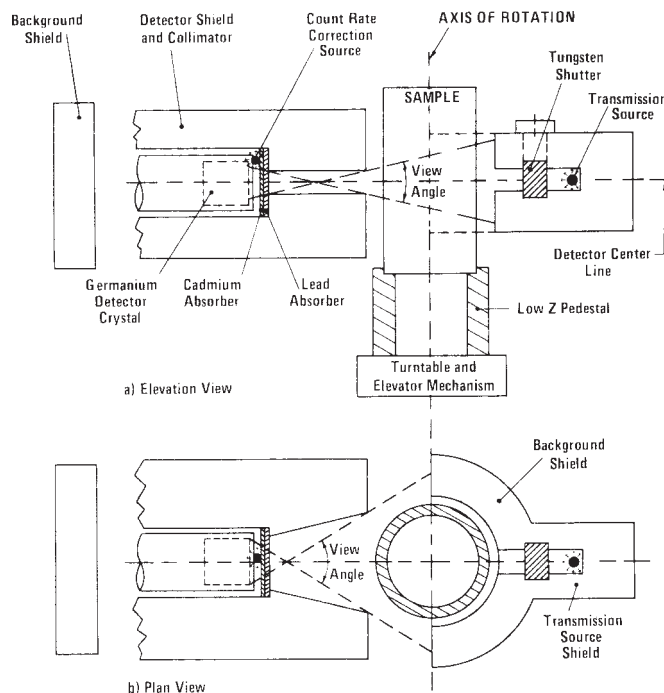

**FIG. 1** Gener Typical Arrangement for Segmented Gamma-Ray Scanning

peak calibration and calibration using mass standards that have the same attenuation characteristics over the energy range used for quantitative measurements as the nuclides of interest in materials to be assayed.

3.6.1.2 An alternative approach to mass calibration with standards that contain the entire container same sized particles is to apply correction algorithms that are calculated based on comparisons to appropriate calibration materials. Based on counting statistics for individual segments, precision values are propagated to obtain the estimated precision differential response of two or more peaks at different energies from the analysis.

3.6 In same nuclide. For example, the event that a single nuclide of an element is measured 129 and the total element mass is required (for example, 414 keV peaks of <sup>239</sup>Pu or the 144 and 186 keV peaks of <sup>235</sup>U could be used (see 6.7).

3.6.1.3 The presence of lumps in material being assayed also can be detected using differential peak response algorithms.

3.6.2 The mixture of material within each item segment must be sufficiently uniform to apply an attenuation correction factor, generally computed from a measurement of gamma-ray transmission through the segment.

3.7 The corrected gamma-ray count rates for the nuclides of interest are determined on a segment-by-segment basis. The precision of the measured count rate of each gamma ray used for analysis is also estimated on a segment-by-segment basis. At the completion of the measurement of all segments, corrected count rates are summed, and mass values for the nuclides of interest in the entire container are calculated based either on comparisons to appropriate calibration materials or from the gamma emission rates determined from the segment efficiencies determined over the energy range of interest. Based on counting statistics for individual segments, precision values are propagated to obtain the estimated precision of the analysis.

3.8 In the event that a single nuclide of an element is measured and the total element mass is required (for example, <sup>239</sup>Pu and total plutonium), it is common practice to apply a known or estimated nuclide/total element ratio to the nuclide assay value to determine the total element content.

3.8.1 Isotope ratios can be determined using gamma isotopic analysis techniques such as those described in Test Method C 1030.

#### **4. Significance and Use**

4.1 Segmented gamma-ray scanning provides a nondestructive means of measuring the nuclide content of scrap and waste where the specific nature of the matrix and the chemical form and relationship between the nuclide and matrix may be unknown.

4.2 The procedure can serve as a diagnostic tool that provides a vertical profile of transmission and nuclide concentration within the item.

~~4.3 The procedure is highly automated and requires little operator interaction.~~

~~4.4 Sample~~

4.3 Sample preparation is generally limited to good waste/scrap segregation practices that produce relatively homogeneous items that are required for any successful waste/inventory management and assay scheme, regardless of the measurement method used. Also, process knowledge should be used, when available, as part of a waste management program to complement information on sample parameters, container properties, and the appropriateness of calibration factors.

#### **5. Interferences**

5.1 Radionuclides may be present in the assay item that produce gamma rays with energies that are the same or very nearly the same as the gamma rays suggested for nuclide or transmission measurement. The areas of the closely spaced peaks that are produced in the gamma-ray spectrum cannot be calculated by simple spectroscopic procedures. Peak fitting software routines may be able to resolve closely spaced peaks in some cases; if not, the nuclide of interest may produce other gamma rays that may be used for analysis.

5.1.1 The peak produced by the 661.6-keV gamma ray from <sup>137</sup>Cs would interfere with calculation of the area of the <sup>241</sup>Am peak produced by its 662.4-keV gamma ray. The 721.9-keV gamma ray of <sup>241</sup>Am may be a useful alternative.

5.1.2 The peak produced by the 765.8-keV gamma ray from <sup>95</sup>Nb would interfere with calculation of the area of the <sup>238</sup>Pu peak produced by its 766.4-keV gamma ray. The 786.3-keV gamma ray of <sup>238</sup>Pu may be a useful alternative.

5.1.3 Occasionally, <sup>237</sup>Np is found in the presence of plutonium. The <sup>237</sup>Np daughter, <sup>233</sup>Pa, emits a gamma ray at 415.8-keV along with several gamma rays in the range from 300 to 400 keV. Peaks from these gamma rays would interfere with calculation of the area of the <sup>239</sup>Pu peak produced by its 413.7-keV gamma ray and several other often used peaks ~~produced by from <sup>239</sup>Pu gamma rays.~~ Pu. In this case, the peak produced by the 129.3-keV gamma ray of <sup>239</sup>Pu may be the only reasonable alternative.

5.1.4 The peak produced by the 63.1-keV gamma ray from <sup>169</sup>Yb, sometimes used as the transmission source for <sup>235</sup>U assays, may interfere with calculation of the area of the peak produced by the 59.5-keV gamma ray of <sup>241</sup>Am, which is used as the count rate correction source. The <sup>169</sup>Yb gamma ray can be sufficiently attenuated by placing a cadmium absorber over the transmission source.

~~5.2 In source or the-s problem can be avoided al-together by using a two-pass assay. The first measurement pass measures the intensity of the transmission source for each segment. The second measurement pass measures the intensity of the 413.7-keV <sup>239</sup>Pu gamma-ray emission from each segment with the transmission source shutter closed.~~

5.1.5 Transmission source peaks may have errors introduced by the presence of a radionuclide in the assay material that emits gamma rays at or near one or more of the measured transmission energies. The affected measurements will then be higher than

the actual transmissions through the item, leading to calculation of a lower than actual correction factor and quantity of measured radionuclide.

5.2 In the case of  $^{239}\text{Pu}$  assays using  $^{75}\text{Se}$  as a transmission source, random coincident summing of the 136.00 and 279.53-keV gamma-ray emissions from  $^{75}\text{Se}$  produces a low-intensity peak at 415.5-keV that interferes with calculation of the area of the  $^{239}\text{Pu}$  peak produced by its 413.7-keV gamma ray. The effects of this sum-peak can be reduced by attenuating the radiation from the transmission source to the lowest intensity required for transmission measurements of acceptable precision. ~~The~~ This problem also can be avoided entirely by making a two-pass assay. The first measurement pass measures the intensity of the transmission source for each segment. The second measurement pass measures the intensity of the 413.7-keV,  $^{239}\text{Pu}$  gamma-ray emission from each segment with the transmission source shutter closed. assay.

5.3 Peaks may appear at the gamma-ray energies used for analysis when there is no nuclide present on the turntable. The likely cause is excessive amounts of nuclide stored in the vicinity of the detector. The preferred solution to this problem is removal of the nuclide from the vicinity and restraint of nuclide movements around the system during measurements. If these conditions cannot be met, sufficient shielding must be provided to eliminate these peaks. Shielding opposite the detector, on the far side of the item to be assayed, will also help to reduce the amount of ambient radiation seen by the detector (see Fig. 1).

## 6. Sources of Error

6.1 Sources of error specifically applicable to segmented gamma-ray scanning are discussed in this section. General descriptions of sources of error encountered in gamma-ray nondestructive assay systems can be found in ANSI N15.20, ANSI N15.35, and NRC Regulatory Guide 5.11.

6.2 The bias in an assay is strongly dependent on how well the attenuation for each segment has been determined. In order to determine the attenuation, a radioactive source with a gamma ray of nearly the same energy as the gamma ray of the nuclide of interest is positioned directly opposite the gamma-ray detector, on the far side of the assay item (see Table 1 for suggested nuclide/transmission source combinations and Fig. 1 for geometry). At lower energies, where the mass attenuation coefficient varies rapidly, it is useful to find a source that produces gamma rays with energies that bracket the energy of the gamma ray from the nuclide of interest. This test method provides a more accurate procedure for calculation of attenuation at the energy of interest. At higher energies, where the mass attenuation coefficient varies more slowly, a transmission source with a single gamma ray of nearly the same energy as the nuclide of interest ~~should~~ may provide a sufficiently accurate determination of attenuation.

6.3 Radionuclides emitting low-energy radiation, especially  $^{241}\text{Am}$ , may contribute a large fraction of the total count rate. The low-energy radiation may be reduced by the use of fixed absorbers, typically cadmium, tin, or lead, between the ~~measurement~~ assay item and the detector (see Fig. 1 and 7.2.157).

6.4 Radionuclides emitting high-energy radiation will contribute Compton-continuum under peaks to be used for the assay. The Compton-continuum will worsen the estimated precision calculated from the counting statistics. The assay of  $^{235}\text{U}$  is normally performed using  $^{169}\text{Yb}$  as the ~~transmission-correction~~ source. This source provides 177- and 198-keV gamma rays that allow accurate calculation of the transmission at 185.7-keV, the energy of the gamma ray from  $^{235}\text{U}$  normally used for assays. The problem of added Compton-continuum from the Yb source can be avoided by making a two-pass assay. If the high-energy gamma rays are from the ~~measurement~~ assay item itself, but not from the nuclide of interest, it may be possible to eliminate them from future ~~measurement~~ assay items by scrap and waste segregation procedures. Such procedures are discussed in detail in NRC Regulatory Guide 5.11.

6.5 ~~¶~~If the transmission source nuclide or radionuclide with one or more gamma rays of similar energy is in the assay material, a two-pass assay allows the passive scan data to be used as the background for the transmission measurement.

6.6 Variations in item composition and density within a vertical segment lead to indeterminate errors. Such variations should be minimized through ~~strict~~ appropriate scrap and waste segregation procedures.

6.6.7 Some matrix forms are ~~inherently~~ may be unsuitable for the original segmented gamma-ray analysis procedures.

6.6.7.1 Such forms may contain lumps of nuclide, that is, nuclide contained in small volumes of ~~matrix material~~ having a localized density substantially different from the bulk density of the rest of the container. The dimensions of nuclide particles that

**TABLE 1 Suggested Nuclide/Source Combinations for Segmented Gamma-Ray Assay**

Nuclide	Peak Energy, keV	Transmission Source	Peak Energy, keV	Count Rate Correction Source	Peak Energy, keV
$^{235}\text{U}$	185.7	$^{169}\text{Yb}$	177.2, 198.0	$^{241}\text{Am}$	59.5
$^{235}\text{U}$	185.7	$^{169}\text{Yb}$	177.2, 198.0	$^{241}\text{Am}$	59.5
$^{238}\text{U}$	1001.1	$^{54}\text{Mn}$	834.8	$^{137}\text{Cs}$	661.6
$^{238}\text{U}$	1001.1	$^{54}\text{Mn}$	834.8	$^{137}\text{Cs}$	661.6
		$^{60}\text{Co}$	1173.2, 1332.5		
$^{237}\text{Np}$	311.9	$^{203}\text{Hg}$	279.2	$^{235}\text{U}$	185.7
$^{238}\text{Pu}$	766.4	$^{137}\text{Cs}$	661.6	$^{133}\text{Ba}$	356.3
$^{239}\text{Pu}$	413.7	$^{75}\text{Se}$	400.1	$^{133}\text{Ba}$	356.3
$^{239}\text{Pu}$	413.7, 129.3	$^{75}\text{Se}$	400.1	$^{133}\text{Ba}$	356.3
$^{241}\text{Am}$	662.4	$^{75}\text{Se}$	400.1	$^{133}\text{Ba}$	356.3

constitute a lump vary with the energy of the emitted radiation used for the analytical measurement. The possible magnitude of the problem may be estimated from examples of attenuating effects provided in Note 1.

NOTE 1—A plutonium metal sphere 0.02 cm in diameter will absorb approximately 4 % of the 414-keV  $^{239}\text{Pu}$  gamma rays produced. Approximately 15 % of the 186-keV  $^{235}\text{U}$  gamma rays will be absorbed in a uranium metal sphere of the same diameter (12).

6.67.2 The presence of lumps of plutonium may be detected and, in some cases, a corrected value calculated using the MESGS technology, various correction algorithms. The technique uses transmission-corrected assay results for multiple gamma-ray energies from a single isotope nuclide and a weighting function to account for self-absorption by lumps. This approach has been used only primarily for the analysis of  $^{239}\text{Pu}$  using a  $^{75}\text{Se}$  transmission source, of  $^{239}\text{Pu}$ , where both the nuclide of interest and the transmission source emit gamma rays over a range of several hundred keV. The success of the lump correction calculations is not universal (6–8), however, and the technique must be evaluated for specific material streams prior to implementation.

6.67.3 Another condition that will cause measurement problems is presented by containers with several irregular regions, radically heterogeneous contents having highly variable in densities and non-uniform activity distributions, that prevent the calculation of a valid attenuation correction based on the transmission measurement. In the case of such a condition, an analytical method less sensitive to nuclide and matrix densities, such as passive neutron coincidence counting as described in Test Method C-1207, densities should be used.

6.78 The nature of the segmenting process leads to end effect problems. During counting, the detector's field of view in the vertical direction is larger than the horizontal extensions of the top and bottom planes of the collimator (see Fig. 1). Throughout most of the item, the results of this overview present no particular problem since calibration procedures effectively account for it. However, the top and bottom segments present particular problems. If the limits of the scan are set to match the top and bottom of the item to straight line extensions of the collimator's top and bottom planes, the nuclide material in the top and bottom segments is viewed for a period of time 65 to 80 % as long as nuclide toward the center of the measurement assay item. Simple overseanning Scanning beyond the end of the item is likely to overestimate the nuclide content of the bottom segment due to the high density of the turntable itself and underestimate the nuclide content of the top segment as the detector looks over the top of the item. One way to decrease this problem involves the placement of a hollow cylindrical pedestal with high transmission between the item and the turntable (see Fig. 1), combined with overseanning scanning beyond the end of the item on both ends. Another option, more difficult to implement, involves the previous two steps along with application of the measured attenuation from the nearest item segment, to the appropriate, overscanned segments (1,7).

## 7. Apparatus

7.1 The following considerations apply specifically to segmented gamma-ray scanners. General guidelines for the selection of detectors and signal processing electronics are discussed in Guide C 982 and NRC Regulatory Guide 5.9. Data acquisition systems are considered in ANSI N15.37 and NRC Regulatory Guide 5.9.

7.2 Complete hardware and software systems for high-resolution, segmented gamma-ray scanning of both large and small items of waste and scrap containing SNM are commercially available. It is recommended that the system have the following components:

7.2.1 *High-Resolution, Coaxial Germanium Detector*—Detector equipped with a high-count rate, resistive feedback preamplifier. Coaxial detectors should have a relative efficiency appropriate electronics to handle the required count rates. A wide range of 10 % or greater (ratio of Germanium crystal volumes are available. Crystal dimensions determine the area under the 1.33-MeV peak efficiency of  $^{60}\text{Co}$  to that obtained the detector. Detectors with a 76 by 76 mm (3 by 3 in.) NaI(Tl) detector, at a source to detector distance efficiencies ranging over more than an order of 25 cm; magnitude are available as standard products. Detectors with resolutions better than 850 eV, eV full width at half maximum; at 122-keV ( $^{57}\text{Co}$ ) are recommended. Test procedures for detectors are given in Test Methods E 181, ANSI/IEEE 325, and ANSI/IEEE 645-ANSI N42.14.

7.2.2 *Spectroscopy Grade Nuclear-Pulse Amplifier*—Amplifier offering selectable pulse shaping time constants (1, 2, and 4  $\mu\text{s}$  values should be available as a minimum), pole-zero adjustment, active-gated baseline restoration, pulse pile-up rejection, and a preamplifier power supply. The pulse pile-up rejection signals from the amplifier must be compatible with the multichannel analyzer described in 7.2.7. A discussion of these functions is given in Guide C 982.

7.2.3 *Oscilloscope*—Oscilloscope providing selectable time bases ranging from 1 ms/cm to 0.5  $\mu\text{s}/\text{cm}$  (20 MHz) and selectable vertical sensitivities ranging from 5 V/cm to 10 mV/cm for proper adjustment of the various amplifier controls is required.

7.2.4 *Spectrum Stabilizer*—Stabilizer monitoring two separate spectrum peaks, to control changes in both energy gain and zero intercept. The stabilizer must be compatible with the multichannel analyzer described in 7.2.7.

7.2.5 *High-Voltage Bias Supply*—Supply equipped with a continuously adjustable voltage control and with a voltage range compatible with the requirements of the detector above.

7.2.6 *Count-Rate Meter*—Meter compatible with output provided by the amplifier.

7.2.7 *Multichannel Analyzer*—Analyzer with a minimum of 4096 data channels is recommended. The analyzer should operate using a Wilkinson-type analog-to-digital converter (ADC) with a minimum ADC clock rate of 100 MHz, or a fixed conversion time ADC with a maximum conversion time of 10  $\mu\text{s}$ . Facilities must be provided to activate the analyzer functions by the controlling computer and to transmit count data to the computer. All of these functions may be provided in either a single unit or in two components, an ADC and a separate data storage unit. Facilities for spectrum display may be provided in either the analyzer itself

or separately in equipment compatible with the ADC/data storage units.

~~7.2.8 Computer~~—Computer equipped with sufficient memory and disk mass storage is required appropriate for system control, data reduction, and report generation. Interface capability for computer control of analyzer functions, scan table control, operator input to the system, assay hardware, performance of analysis computations, and analytical report output must also be provided.

~~7.2.9 Interactive Terminal~~—Terminal compatible with the computer described in 7.2.8 is required for system display and measurement control.

~~7.2.10 Hardcopy Printer~~—Printer compatible with storage of the computer described in 7.2.8 is required for system documentation data and analytical report generation.

~~7.2.11 results.~~

~~7.2.3 Motorized, Vertical Scanning Turntable~~—Turntable capable of accommodating the largest size and weight containers to be measured is required. Computer-actuated methods for controlling vertical movement include timers and stepping motors and allow a choice of segment size. For normal analyses, segment sizes between the height of the collimator and one-half the collimator height provide sufficient segmentation. ~~Segment sizes equal to one-half the height of the collimator slit~~ The system should provide the maximum sensitivity to nuclide located in any portion of the container. Vertical movement acceptable detector-assay item positioning accuracy and repeatability within  $\pm$  ( $\pm$  0.5 % of the segment height should be available; range of travel is commercially available). Both helical or fixed-segment counting schemes are acceptable, and either the assay item or the detector-collimator and transmission source shield assemblies can be moved. The turntable rotational speed should provide either a large number of rotations (ten or more) or a small integral number of rotations during the counting period for each segment.

~~7.2.124 Detector Collimator~~—Collimator constructed of lead or tungsten serves to define the detector's horizontal and vertical viewing angles and to shield the detector from ambient radiation. A deep collimator (front to back), along with close coupling of the collimator and measurement assay item, reduces the vertical viewing angle and improves segmentation. The reduced viewing angle decreases the bias of the attenuation correction and decreases the severity of end effects. ~~These benefits must be balanced against a decrease in overall sensitivity (count rate/gram), due both to the more restricted field of view and to the greater distance of the detector from the nuclide.~~ Collimator slit heights should be chosen so as to be in the range of  $\frac{1}{8}$  to  $\frac{1}{16}$  of the height of the measurement assay item. The horizontal field of view must include the entire diameter of the item.

~~7.2.12.1 Large Items~~—For item. Lining the inside of the collimator with appropriately-thick sheets of cadmium or tin and copper will eliminate collimator lead X-rays from the spectrum.

~~7.2.4.1~~ For large items, where high efficiency is required for reasonable count times, the height of the collimator slit should be approximately equal to the diameter of the detector crystal. In practice, collimator depth/height ratios of two to four for 208-L (55-gal) drum-sized items is are reasonable.

~~7.2.12.2 Small Items~~—Smaller

~~7.2.4.2~~ Smaller items require narrower (vertical) collimators to maintain the benefits of accurate attenuation corrections and to minimize end effects. A collimator depth/height ratio of six to ten is reasonable.

~~7.2.135 Count-Rate Correction Source~~—Correction source is chosen to have gamma-ray emission energies that are lower than the energy of the gamma ray from the nuclide of interest in order to avoid Compton interferences. These sources can be obtained as 5 to 10  $\mu\text{Ci}$ , flat plastic wafer, sealed sources, for easy attachment close to the cryostat of the detector. Recommended sources are listed in Table 1. A combination of cadmium or tin and copper (closest to the detector) foils positioned under the source reduce the effect of abundant low-energy gamma rays that are present with some of the suggested count-rate correction sources. The position of the source ~~on the cryostat~~ is adjusted to produce a count rate providing sufficient precision for the assay times used and then fixed in place. Alternatively, an electronic pulser can be used for count rate correction.

~~7.2.146 Transmission Source~~—Transmission source must be considerably stronger than the count-rate correction source to perform effectively. Ten to 50 mCi sources for small item counters and 50 to 100 ~~mCi~~  $\mu\text{Ci}$  sources for barrel size counters, in the shape of small diameter rods, are well suited to use in cylindrical lead or tungsten shields. These shields reduce radiation exposure to workers and collimate the radiation from the transmission source to a narrow slice of region containing the detector. If an assay system is to be calibrated for multiple radionuclides, it may be useful to select a transmission source having multiple gamma ray energies (with appropriate relative intensities), and use a suitable method to determine transmissions at the radionuclide analysis energies. Table 1 provides a listing of suggested nuclides for use as transmission sources, with the listed nuclides of interest. ~~Because some of the suggested an otherwise appropriate source isotopes can~~ be relatively short-lived, it may be necessary to obtain ~~them~~ one with an activity considerably above the optimum to provide for a useful working life. The count rate of a new sources may be attenuated by collimation, absorbers directly in front of the source, source-to-detector spacing, or some combination thereof. For the most accurate assays in cases in which the half-life of the transmission source isotope is short, a mathematical decay calculation to determine current source strength should be made for each measurement. In the case of assays where gamma-ray peaks from the transmission source interfere with determination of the area of the gamma-ray peak used for nuclide analysis, peak fitting software may be able to resolve overlapping peaks or a two-pass assay may be ~~required; used~~. In cases that ~~require~~ employ a two-pass assay, equip the transmission source collimator with a computer-actuated shutter, preferably tungsten, to block the transmission source from the gamma-ray detector during one of the passes (see Fig. 1). As a safety consideration, design such shutters so that, in the event of a power failure, the shutter will shut off the radiation beam automatically.

~~7.2.157 Absorber Foils~~—Foils must generally be used to reduce the contribution of low-energy gamma rays to the overall count

rate, especially in the assay of  $^{239}\text{Pu}$ . As mentioned in 7.6.3, cadmium or tin foils serve to absorb the low-energy gamma rays from the item. For  $^{239}\text{Pu}$  assay, a series of 0.5-mm (approximately 0.020-in.) cadmium or tin foils can serve for sensitivity versus interference optimization. The use of lead foil is likely to require the additional use of cadmium or tin and copper foils as secondary absorbers (closest to the detector) to reduce the intensity of the fluorescent X rays produced in the lead foil. A single 1-mm cadmium or tin foil may be appropriate for  $^{235}\text{U}$  assay. Once a combination is chosen, it cannot be changed without instrument recalibration.

## 8. Calibration and Reference Materials

### 8.1 Calibration:

8.1.1 *Isotope Specific (Mass) Calibration* of a segmented gamma-ray scanning instrument involves using a series of calibration items to determine the relationship between the observed, totally corrected count rate of a nuclide's characteristic gamma ray and the mass of nuclide known to be present. For this method, the radioisotope calibrated for is actually present in the calibration standards. With the correction of individual segment count rates for rate-related losses and the attenuation of each segment, a direct proportionality between count rate, summed over all segments of an item, and total nuclide mass is obtained. Guide C 1156 provides background information useful in developing a calibration plan. See 10.3.2 through 10.3.12, 10.3.14, and 10.3.15 for details.

8.1.2 *Efficiency Calibration* of a segmented gamma-ray scanning instrument involves using calibration standards to determine for each segment the ratio of the observed, corrected count rate of each of a number of gamma rays from the standard to its known emission rate within the segment, and use these ratios (efficiencies) to define the system detection efficiency as a function of energy. A detector efficiency value appropriate to the gamma ray energy is then applied to each individual segment corrected count rate (corrected for attenuation and rate-related losses) and summed over all segments of an item. The sum is adjusted by the specific activity and gamma ray intensity to determine the radionuclide mass. For this method, the radioisotopes in the calibration standards are chosen based on their half-lives and gamma energies and typically are not the same as the isotopes for which the calibration is used. See 10.3.2 through 10.3.11 and 10.3.13 through 10.3.15.

8.1.3 Perform calibrations using the same procedures and conditions that will be used for the assays of actual waste items. These include, but are not limited to, electronic components, peak area determination procedures, procedures for the determination of counting losses, segment sizes, absorber foil combinations, collimator arrangements, and measurement geometries. Alternatively, differences between calibration and assay geometries can be corrected for by appropriately calculated correction factors (13).

8.1.34 Ref (5), Guide C 1128, ANSI Standards N 15.20 and N 15.35, and NRC Regulatory Guide 5.53 provide useful guidelines for the preparation and characterization of calibration materials and calibration procedures and the statistical analysis of data. Where there are conflicts among the documents, Ref (5) reflects information most specific to SGS requirements.

### 8.2 Reference Materials for Isotope Specific Calibration:

8.2.1 Prepare small item calibration items by uniformly dispersing known masses of stable chemical compounds with a known isotopic mass fraction of the radionuclide of interest throughout a stable diluting medium such as graphite, diatomaceous earth, or castable silicon compounds (see ANSI N 15.35). compounds. The radioactive material should have a particle size small enough so that the effects of self-attenuation within each particle are negligible. With this requirement satisfied, choose the best particle size range to form a stable, homogenous mixture with the diluting material. Although the segmentation procedure used by the instrument usually compensates for stratification of the components of the mixture over time, some mixing, provided by gently shaking or rolling the container prior to each measurement, may be useful for calibration items containing powder.

8.2.2 Construct calibration items for larger item types such as 208-L (55-gal) drums from modules of matrix material such as filter paper, fiberglass, etc., wetted with known quantities of solutions containing the nuclide of interest at a known concentration. Dry the modules and pack them in plastic bags. Place the modules into the drum in a uniform manner until the drum is filled. Modules with varying nuclide loadings and varying combinations of modules produce a range of item loadings. For purposes of the initial calibration process, the mass of nuclide in individual modules should be limited so as not to create self-attenuating lumps (Note 1). Where possible, eliminate voids and small volumes containing high concentrations of nuclide (124).

8.2.3 For each item geometry, prepare a set of three calibration items of differing nuclide mass. The mass loadings and the gamma-ray transmissions through the calibration items should span the ranges expected in the unknowns.

8.2.4 In order to evaluate the magnitude of biases that will be caused by the deviation of real items from ideal distributions of matrix and nuclide, prepare representative items from segregated varieties of scrap and waste materials typical of expected assay items. Vary the spatial distribution of the nuclide from widely dispersed to concentrated in various extreme dimensions of the container volume. Comparison of the assay results for such representative items with the known nuclide masses will indicate the possible range of bias caused by heterogeneity of nuclide and matrix material and that caused by nuclide location within the item.

8.2.5 Nuclide particle sizes in ~~measurement~~ assay items may vary from those in the calibration ~~items, standards,~~ causing variations in the count rate per gram of nuclide and yielding biased results. An acceptable alternative to the preparation of special representative ~~items standards~~ for calibration and uncertainty estimation measurements is the assay of real items (actual process materials) by analytical methods less sensitive to particle size problems (see ~~ANSI N 15.35 and~~ NRC Regulatory Guide 5.53). These analytical methods may be total dissolution and solution quantification after completion of the segmented gamma-ray measurements (135), or combined gamma-ray isotopic and calorimetric assay for plutonium materials. In either case, the determination of biases for ~~real these~~ items will require special attention.

### 8.3 Reference Materials for Efficiency Curve Calibration:

8.3.1 Radionuclide sources for determining an efficiency curve are typically multi-isotope sources having multiple gamma ray energies spanning a broad energy range. The available gamma ray energies should be sufficient to appropriately define the efficiency function over the energy range of interest, generally 50 to 2000 keV.

8.3.2 Line sources prepared by radioisotope source vendors are often used. Line source uncertainties are generally in the range of a few percent at 1 standard deviation. Uncertainties in the data for radionuclide half-lives and gamma ray emission intensities also contribute to the measurement uncertainty. Each of these uncertainties must be included in an uncertainty propagation to determine the total measurement uncertainty (TMU) of an instrument. The TMU should be determined for each container and material type.

8.3.3 Line sources are used by inserting them into appropriately-located holes in a cylinder of non-radioactive matrix material (16). The holes should be small relative to the size of the cylinder and the cylinder should be rotated during counting.

8.3.3.1 Several methods of source placement and measurement can be used: A single measurement using multiple line sources in a matrix drum, multiple measurements with a single source in a different location for each count with the resulting spectra summed, or multiple sets of sources, each providing different gamma ray lines. Each of these methods is used so as to simulate a homogeneous distribution of source activity in the matrix (17).

8.3.4 Calibration sources also can be fabricated using techniques described in 8.2.

## **9. Precautions**

### *9.1 Safety:*

9.1.1 Transuranic materials are both radioactive and toxic. Adequate laboratory facilities and safe operating procedures must be considered to protect operators from both unnecessary exposure to ionizing radiation and contamination while handling measurement assay items (118).

9.1.2 The recommended analytical procedures call for the use of ~~radioactive isotope~~ radioisotope sources, some with high levels of ionizing radiation. Consult a qualified health physicist or radiation safety professional concerning exposure problems and leak test requirements before handling discrete radioactive sources.

### *9.2 Technical:*

9.2.1 Prevent counting conditions that may produce spectral distortions. Use pulse pile-up rejection techniques if high count rates are encountered. Use absorbers when appropriate, to reduce the intensity of low-energy gamma rays such as the 59.54-keV emission of <sup>241</sup>Am (see 6.3 and ~~7.2.157~~). Temperature and humidity fluctuations in the measurement environment may cause gain and zero-level shifts in the gamma-ray spectrum. Use environmental controls or digital stabilization to prevent shifts, or use software to monitor the changes in gain and zero level, and adjust the regions of interest accordingly. Failure to isolate electronic components from other electrical equipment or the presence of noise in the ac power also may produce spectral distortions.

9.2.2 Locate the instrument in an area with as low a gamma-ray radiation background as possible. Prohibit the movement of containers of radioactive material in the vicinity of the instrument while an assay is underway.

## **10. Procedure**

### *10.1 Optimization of System Physical Parameters:*

10.1.1 Adjust the instrument controls to optimize signal processing and peak analysis functions. Choose the shaping time constant to optimize the trade-off between improved resolution with longer time constants and decreased dead time losses with shorter time constants. Time constants of 1 to 4  $\mu$ s are commonly used. Choose the system gain so that a sufficient number of channels will be included in peaks to allow visual inspection of peak shapes, without including so many channels that peaks do not develop into recognizable shapes with expected count rates in planned count times. Generally peak shapes can be evaluated by including 10 to 20 channels between the one-tenth maximum boundaries of the peaks. Adjust pole zero and baseline restorer controls, using an oscilloscope in accordance with the manufacturer's instructions. Regions of interest around peaks to be used for analysis may be set manually by the operator or semiautomatically by the computer or analyzer, depending on the software package used.

10.1.2 Choose collimator sizes that are appropriate to the item type to be assayed, using the criteria described in ~~7.2.12~~-7.2.4.

10.1.3 Choose scanning segment sizes that match the item and previously chosen collimator sizes. For normal analyses, when stepped segments are used, limit the segment sizes to between the height of the collimator slit and one-half the height of the collimator slit. When helically scanned segments are used, segments considerably larger than the collimator slit height may be used.

10.1.4 Choose absorber combinations for the detector that match the expected spectral properties of measurement assay items to the desired conditions for the counting system (see ~~7.2.157~~).

10.1.5 Select the segment count time to obtain the sensitivity and precision required while still allowing practical throughput.

10.1.6 Ensure that the turntable rotational speed provides either a large number of rotations (ten or more) or a small integral number of rotations during the counting period for each segment.

10.1.7 Position and attenuate the transmission and count-rate correction sources to provide sufficient precision for the count time chosen.

### *10.2 Measurement of Initial System Parameters:*

10.2.1 Measure and store for later use, the following basic parameters for system sources and measurement assay item containers:

10.2.1.1 Count-rate correction source intensity and the date of measurement.

10.2.1.2 Unattenuated transmission source intensity, corrected for count-rate related losses, and the date of measurement.

10.2.1.3 Empty container transmission.

10.2.1.4 Establish the minimum acceptable transmission source count rate for assays, based on the transmission source strength and acceptable precision.

10.2.1.5 Determine the degree of interference between transmission and nuclide peaks and the need for two-pass assays determined (most likely to be required for the assay of  $^{235}\text{U}$ , also possibly with plutonium at low mass loadings).

10.3 *Calibration of System:*

10.3.1 Measure a series of appropriate calibration items containing known quantities of nuclide, prepared as described in 8.2.1 through 8.2.3.

10.3.2 While rotating standards, count each, segment by segment. Peak areas for nuclide, transmission source, and count-rate correction source usually may be calculated using the most basic peak area determination technique, that is, channel summation and straight line Compton continuum background subtraction, as shown in Eq 1. In this procedure, the background regions should be located, one on each side of the peak, as near the peak as possible, in areas where the spectrum is relatively flat. The peak region of interest must not overlap either of the background regions of interest.

$$A = P - \left[ \frac{NP}{2} \left( \frac{B_1}{NB_1} + \frac{B_2}{NB_2} \right) \right] \quad (1)$$

where:

$A$  = net peak area (counts) for nuclide, transmission, and count-rate correction peaks,

$P$  = total counts in peak region of interest for nuclide, transmission, and count-rate correction peaks,

$NP$  = number of channels summed for  $P$ ,

$B_1$  and  $B_2$  = counts in each background region, and

$NB_1$  and  $NB_2$  = number of channels in each background region.

10.3.3 Calculate the estimated variance for each peak area due to counting statistics. The formula given in Eq 2 is valid when peak areas are determined by the channel summation and straight line background subtraction formula given in Eq 1. If a different peak calculation method is used, an appropriate variance calculation will be required.

$$\sigma^2(A) = P + \left[ \left( \frac{NP}{2 \times NB_1} \right)^2 \times B_1 \right] + \left[ \left( \frac{NP}{2 \times NB_2} \right)^2 \times B_2 \right] \quad (2)$$

where:

$\sigma^2(A)$  = estimated variance of peak area due to counting statistics. All other terms are the same as in Eq 1.

10.3.4 For each segment,  $i$ , correct the nuclide and transmission peak areas for count rate-related losses (deadtime and pulse pile-up) based on the observed activity change in the count-rate correction source. The activity of the count-rate correction source will be unaffected by the assay of the nuclide. Any observed decrease in the source count rate during the assay, compared with the count rate when no other sources are present, is used to calculate a correction factor to be applied to all other peaks used for the analysis.

$$A_i' = A_i \times \frac{LT_o}{LT_i} \quad (3)$$

where:

$A_i'$  = net nuclide or transmission peak area for the  $i^{\text{th}}$  segment corrected for rate-related losses,

$A_i$  = observed net nuclide or transmission peak area for the  $i^{\text{th}}$  segment,

$LT_o$  = measured net peak area of the count rate correction source with no other sources present, normalized to a collection time equal to that of  $A_i$ , and

$LT_i$  = observed net peak area of the count rate correction source for the  $i^{\text{th}}$  segment.

10.3.5 For each segment, convert the peak area to a count rate and correct the nuclide peak count rate to account for item attenuation. This correction has two components, one accounting for container attenuation, and the second accounting for attenuation due to the container contents (5):

$$CC_i = \frac{A_i'}{t} \times CF_i(T_i') \times CF_{\text{can}} \quad (4)$$

where:

$CC_i$  = totally corrected nuclide peak count rate of the  $i^{\text{th}}$  segment,

$A_i'$  = net peak area of the  $i^{\text{th}}$  segment, corrected for rate-related losses (from Eq 3),

$t$  = counting time for the  $i^{\text{th}}$  segment,

$CF_i(T_i')$  = attenuation correction factor for the  $i^{\text{th}}$  segment due to attenuation by the container contents, and

$CF_{\text{can}}$  = attenuation correction factor due to attenuation by the container wall.

~~10.3.5.1 A more versatile, but mathematically more complex method for calculating the attenuation correction factor for the contents of an item is presented in Ref (7).~~

10.3.6 The attenuation correction factor due to the container wall at the energy of the nuclide gamma ray derives from the measured transmission of an empty container and can be approximated as:

$$CF_{\text{can}} = \frac{1}{(T_c)^{1/2}} \quad (5)$$

where:

$CF_{\text{can}}$  = attenuation correction factor due to the container wall at the energy of the nuclide gamma ray (calculated during calibration and stored for use during item assays), and

$T_c$  = measured empty container transmission at the energy of the nuclide gamma ray (calculated during calibration).

10.3.7 Determine the transmission of the empty container using a source that produces either gamma rays with energies that bracket the energy of the gamma ray from the nuclide of interest, or a single gamma ray of nearly the same energy as the nuclide.

10.3.7.1 For the general case of two transmission peaks that bracket the assay energy and are close to it, the measured transmissions can be linearly interpolated:

$$T_c = WA \times \left( \frac{TA_i'}{TA_o'} \right) + WB \times \left( \frac{TB_i'}{TB_o'} \right) \quad (6)$$

~~10.3.7.2 For a single transmission peak:~~

$$T_c = \left( \frac{TA_i'}{TA_o'} \right)^{KA} \quad (7)$$

where:

$T_c$  = container transmission at the energy of the assay nuclide gamma ray (calculated during calibration),  
 $WA$  and  $WB$  = transmission source weighting factors used to calculate the transmission of the container wall at the energy of the nuclide. ~~Weighting factors are normally based on a linear interpolation of the ln(energy) versus ln(-ln(transmission)) values measured during calibration.~~ The sum of the weighting factors must equal one.

As an example, for  $^{235}\text{U}$  assays using the 185.7-keV peak with  $^{169}\text{Yb}$  as the transmission source, the weighting factor for the 177.2-keV peak is approximately 0.6; for the 198-keV peak, it is approximately 0.4.

$TA_i'$  and  $TB_i'$  = transmission source peak areas, measured through an empty container, corrected for rate-related losses, and

$TA_o'$  and  $TB_o'$  = transmission source peak areas, measured with no container present, corrected for rate-related losses.

10.3.7.2 For a single transmission peak:

$$T_c = \left( \frac{TA_i'}{TA_o'} \right)^{KA} \quad (7)$$

where:

$KA$  = ratio of the linear attenuation coefficients at the nuclide ( $\mu_N$ ) and transmission source ( $\mu_A$ ) energies (from literature or experimental sources):

$$KA = \frac{\mu_N}{\mu_A} \quad (8)$$

10.3.8 For each segment, ~~calculate~~ the attenuation correction factor, due to the attenuation of the contents, assuming homogeneity, can be approximated by (5):

$$CF_i(T_i') = \frac{-B \times \ln(T_i')}{1 - (T_i')^B} \quad (9)$$

where:

$CF_i(T_i')$  = attenuation correction factor for the  $i^{\text{th}}$  segment due to the attenuation of the container contents at the energy of the nuclide gamma ray,

$B$  = ~~geometric correction~~ geometry factor (typically 0.70 to 0.823 for cylinders) (5,13), and

$T_i'$  = transmission of the container contents in the  $i^{\text{th}}$  segment at the energy of the nuclide gamma ray.

10.3.8.1 An alternative approach to the approximation shown in Eq 9 for calculation of attenuation correction factors makes use of techniques presented in Ref (5) . Also, a versatile method for calculating the attenuation correction factor for the contents of an item is presented in Ref (7).

10.3.9 Calculate the transmission of the  $i^{\text{th}}$  segment of the container contents at the energy of the nuclide gamma ray, as with the empty container transmission in 10.3.7, using one of ~~two equations~~, several methods, depending on whether one, two, or ~~two~~ more transmission peaks values are used.

10.3.9.1 For two measured transmission p values at energies bracketing the assay energy and close to it:

$$T_i' = \frac{WA \times \left(\frac{TA_s'}{TA_o'}\right) + WB \times \left(\frac{TB_s'}{TB_o'}\right)}{T_c} \quad (10)$$

10.3.9.2 For a single measured transmission ~~peak~~ ~~value~~:

$$T_i' = \frac{\left(\frac{TA_s'}{TA_o'}\right)^{KA}}{T_c} \quad (11)$$

$$T_i' = \frac{\left(\frac{TA_i'}{TA_o'}\right)^{KA}}{T_c} \quad (11)$$

10.3.9.3 For two or three measured transmission values at energies in reasonable proximity of the nuclide analysis energy, determine the coefficients in Eq 12 for a linear ( $C2 = 0$ ) or quadratic ( $C2 \neq 0$ ) fit to the transmission data and then calculate the interpolated transmission value for the segment:

$$\ln(-\ln T_i) = C2 \cdot \ln(E_j)^2 + C1 \cdot \ln(E_j) + C0 \quad (12)$$

10.3.9.4 Materials Basis Set (MBS) method based on values of the mass attenuation coefficient  $\mu(E)$  as a function of energy (19). Use  $\mu(E)$ , for example, for carbon and uranium or plutonium, determine coefficients  $C1$  and  $C2$  in Eq 13 to fit two or more measured transmission values, and then calculate segment transmissions at the nuclide analysis energies using Eq 13. This method takes advantage of the known energy dependence of  $\mu(E)$  in performing the energy interpolation. The method can be extended to three or more terms, or  $\mu(E)$  appropriate to the material being assayed can be used for the expansion; for example, for assays of soil samples,  $\mu(E)$  for an appropriate soil composition could be included.

$$\ln(T_j) = C1 \cdot \mu_c(E_j) + C2 \cdot \mu_v(E_j) \quad (13)$$

where:

- $T_i'$  = transmission of the container contents for the  $i^{\text{th}}$  segment, at the energy of the nuclide gamma ray,
- $WA$  and  $WB$  = transmission source weighting factors, see 10.3.7,
- $TA_s'$  and  $TB_s'$  = transmission source peak areas, measured through the container and contents at the  $i^{\text{th}}$  segment, corrected for rate-related losses,
- $TA_o'$  and  $TB_o'$  = transmission source peak areas, measured during calibration, with no container present, corrected for rate-related losses,
- $KA$  = ratio of the linear attenuation coefficients at the nuclide and transmission source energies (see Eq 8), and 8),
- $T_c$  = container transmission at the energy of the nuclide gamma ray, measured during calibration,
- $C0, C1, \text{ and } C2$  = constants for interpolation of transmission values, to be determined by fit to measured transmissions, and
- $T_j, E_j$  = measured or interpolated transmission and corresponding gamma energy.

10.3.10 Sum the totally corrected nuclide peak count rate values for each segment to obtain a count rate value proportional to the nuclide content of each standard.

10.3.11 Using the variances calculated for the individual peaks measured in each segment, propagate the precision of the total, corrected nuclide count rate, due to counting statistics, for each standard. A complete discussion of this procedure is provided in Annex A1.

10.3.12 *Isotope Specific Calibration* :

10.3.12.1 In ideal situations in which there are no interferences or background radiation, the calibration will be described by a single factor relating nuclide loading to total, corrected count values.

$$M = \frac{CC}{G_1} \quad (14)$$

where:

- $M$  = nuclide mass,
- $CC$  = total corrected nuclide peak count rate, summed over all segments of an item, and
- $G_1$  = proportionality (calibration) constant (counts/second/nuclide unit mass).

10.3.12.2 For less than ideal situations, analyze the calibration data by linear least squares methods to obtain a calibration equation (slope and intercept) that relates nuclide loading to the observed, total, corrected nuclide count rate values:

$$M = \frac{CC - G_0}{G_1} \quad (15)$$

where:

- $M$  = nuclide mass,
- $CC$  = total corrected nuclide peak count rate, summed over all segments of an item,
- $G_0$  = additive constant (counts/second), and
- $G_1$  = proportionality (calibration) constant (counts/second/nuclide unit mass).

### 10.3.13 Calculate

Note that the precision range of validity of these parameters is an essential aspect of the calibration parameter set. The range is based on the mass range of the standards used in the calibration.

#### 10.3.13 Efficiency Curve Calibration :

10.3.13.1 An efficiency versus energy relation for each segment is determined using the corrected count rates from gamma peaks from the standard divided by the known gamma emission rates in the segment at those energies.

10.3.13.2 Using the efficiency function for each segment, corrected count rates from gamma peaks of interest, and half life and gamma intensity data for the associated radionuclides, the mass  $M(Iso, E_\gamma)$  of each measured radionuclide Iso determined from the gamma ray at energy  $E_\gamma$  is calculated as follows:

$$M(Iso, E_\gamma) = \frac{1}{SA(Iso) \times I_\gamma(Iso, E_\gamma)} \times \sum_{i=1}^N \frac{CC(E_\gamma)_i}{\epsilon(E_\gamma)_i} \quad (16)$$

where:

$M(Iso, E_\gamma)$  = mass of the isotope determined from the gamma ray of energy  $E_\gamma$ .

$N$  = number of segments scanned,

$CC(E_\gamma)_i$  = corrected count rate for segment  $i$  for the peak of energy  $E_\gamma$ .  $CC(E_\gamma)_i$  is corrected for count rate effects and for geometry and attenuation effects,

$\epsilon(E_\gamma)_i$  = efficiency of the detector at energy  $E_\gamma$  for segment  $i$  for a source having the same geometry as the samples,

$SA(Iso)$  = specific activity (Becquerels per gram) of the isotope Iso emitting gammas of energy  $E_\gamma$ , and

$I_\gamma(Iso, E_\gamma)$  = intensity (gammas per disintegration) of the gamma of energy  $E_\gamma$  emitted by the methods detailed isotope Iso.

Note that the assay energies  $E_\gamma$  must be bracketed by energy points used in Annex A1, the determination of the efficiency curve. Otherwise, large errors can be introduced.

10.3.13.3 As part of the calibration process, the efficiency functions  $\epsilon(E_\gamma)_i$  and constant  $B$  (Eq 9) defined above must be determined for each standard measurement. The sample geometry to be assayed, and calibration precision may parameters appropriate to the sample geometry must be selected for each measurement control run or assay.

10.3.13.4 To determine the  $\epsilon(E_\gamma)_i$  functions, data should be collected from one or more counts of the same standard and, if additional standards are available, one or more counts of other standards, and then the weighted averages (weighted by the inverse variance) of the efficiency values at each energy  $E_\gamma$  should be fit with the function  $\epsilon(E_\gamma)_i$  using a technique such as Least Squares or Gauss Linear Squares to determine the function coefficients. Numerical methods can be used to determine the uncertainties in the efficiency values  $\sigma(\epsilon(E_\gamma)_i)$ . A complete mathematical treatment of this process is beyond the overall assay precision scope of this standard.

10.3.14 Determine the uncertainty in the calibration coefficient(s), based on the methods detailed in Annex A1. The calibration uncertainty should be included in the uncertainty calculated for each item measured.

10.3.14.5 A sense of the magnitude of possible measurement errors arising from non-ideal distributions of nuclide and variations in matrix composition should be developed. Prepare, or identify and examine, quantify, a series of representative items containing known combinations of matrix material and nuclide loadings that approximate situations that may be reasonably expected represent the items to occur in production items; be assayed, as described in 8.2.4 and 8.2.5. Observed measurement biases for non-ideal measurement configurations must be included in any assessment of measurement quality or determination of the TMU.

#### 10.4 Establishment of Measurement Control Program:

10.4.1 After calibration has been completed, all geometric, physical, and electronic parameters must remain fixed. Any alteration requires recalibration or confirmation that the existing calibration is still valid. In addition, a measurement control program should be established to monitor system parameters and generate reports documenting the status of the system. Monitored characteristics should include, but are not necessarily limited to, system gain and resolution, count-rate correction source and transmission source activity, adherence to established nuclide calibration values, and background radiation levels. Tests are described in Test Methods E 181, ANSI/IEEE 325, ANSI N45.20, and and NRC Regulatory Guide 5.53, along with more general considerations of quality control programs in Guide C 1210.

10.4.2 On a daily or more frequent periodic basis, with the period determined by regulatory and operational requirements, confirm the system gain stability by checking the locations of the count-rate correction, transmission, and nuclide peaks. Minimize peak location shifts by the use of automatic, digital peak stabilization that provides a continuous check and adjustment of system gain and zero level to maintain peak locations (see 7.2.4); locations. Alternatively, use software peak location routines that find peaks regardless of drifting locations. Limitations must still be applied to ensure that peak widths do not change to the point where peak area calculations are compromised.

10.4.3 On a daily periodic basis, check the system resolution of both the high- and low-energy peaks. Limits for resolution change should be set that reflect the ability of the peak area calculation software to adapt to variable peak widths. Significant loss of resolution in the high-energy peak is indicative of neutron damage to the detector. Loss of resolution in the low-energy peak indicates an increase in system noise.

10.4.4 On a daily periodic basis, determine the transmission and count-rate correction source activities and compare them to the values predicted by decay equations. Activity values that differ by more than three standard deviations from the predicted values are an indication of problems to be investigated by the system manager.

10.4.4.1 Consistent, measured count-rate correction source values serve as a monitor of constant detector efficiency and signal processing hardware stability, without regard to the nature of a ~~measurement assay~~ item or hardware geometry.

10.4.4.2 Consistent measured transmission source values serve to monitor hardware geometry stability.

10.4.5 During the ~~daily periodic~~ check of the count-rate correction source activity, check for the presence of interfering background radiation in the region of the nuclide peak. The cause of high or varying levels of background should be eliminated.

10.4.6 On a ~~daily periodic~~ basis, assay a nuclide-containing working standard or, where an interfering background has been identified, two standards with nuclide loadings at the extremes of the calibration range. Such measurements are required to detect shifts in the calibration function and are often called bias checks.

10.4.6.1 Checks of a standard at the low end of the calibration range are a more sensitive verification of the validity of the calibration intercept value (either a real value or zero) and background correction.

10.4.6.2 Checks of a standard at the high end of the calibration range are a more sensitive verification of the calibration (proportionality) constant and count rate correction.

10.4.6.3 Consistent measured values verify the proper operation of both mechanical and electronic hardware.

10.4.7 On a ~~weekly or monthly periodic~~ basis, generally less frequently than the checks described in 10.4.2-10.4.6, perform a precision check of the system by making repeated measurements of a single calibration or inventory item. Compare the variation of the assay results to the assay precision estimated by the software. Variation of the measurements in excess of that attributable to counting statistics, as predicted by the software, indicates undesirable instability in electronic systems or lack of repeatability in mechanical systems.

## 10.5 Measurement of Assay Items :

### ~~10.5.1 Measurement~~

~~10.5.1 Assay items are counted using procedures (segment sizes, etc.), counting geometries, and calculations identical to those used during calibration as described in 10.3.2 through 10.3.13. Count times for ~~measurement assay~~ items may be changed from those used for calibration and measurement control as long as the requirements of 10.1.6 are met. Calculate the nuclide content of the items using Eq-12, 14, Eq 15, or Eq-13, 16 as appropriate.~~

10.5.2 In the course of ~~counting assaying~~ production items, situations may be encountered in which high segment densities produce very low transmission values. Set limits in the analytical software to recognize and act on minimum acceptable transmission levels, based on acceptable accuracy. One percent transmission may be a reasonable level for consideration. If less than minimum acceptable transmission levels are measured, ~~two possible courses of action are suggested:~~

~~10.5.2.1 The problem segment is flagged, a default transmission value (such as 0.01) is assigned for the purpose of estimating nuclide content, and an assumed large uncertainty is assigned to the measurement of that segment. The assay value for such an item must then be reported as *greater than the calculated value*.~~

~~10.5.2.2 The problem segment is should be flagged and no assay value is reported for the item. The assay should be subjected to technical review.~~

## 11. Precision and Bias

11.1 *Precision*—The precision of a segmented gamma scan assay is a function of the precision of the three or four peak areas measured for each segment (Annex A1). The precision of an assay is improved by increasing the number of counts in the peaks or decreasing the Compton continuum under the peaks, or both. The following conditions will tend to improve counting precision:

11.1.1 Increased count time,

11.1.2 High transmission source activity,

11.1.3 Low attenuation for gamma radiation in the energy range of interest, and

~~11.1.4 Increased detector thickness (decreases Compton continuum);~~

11.2 The precision of an assay is not strongly related to the measurement item's adherence to ideal matrix and nuclide density assumptions.

11.3 Normally, an estimate of the repeatability (standard deviation) of an assay is calculated by the computer along with the assay value. For plutonium loadings of 15 g or more, where transmissions are approximately 50 % and segment count times of

**TABLE 2 Observed Reproducibility and Relative Bias for Calibration Standards Using Segmented Gamma-Ray Assay<sup>A</sup>**

Calibration Item Description	10.2-cm Diameter Incinerator Ash	10.2-cm Diameter Incinerator Ash	30-cm Diameter Combustible Waste	30-cm Diameter Combustible Waste	208-L Combustible Waste	208-L Combustible Waste
Reference Pu, g	14.6	87.9	10.13	40.05	19.92	99.95
Segment size, cm	1.27	1.27	1.27	1.27	4.13	4.13
Number of segments	15	15	31	31	21	21
Segment type	step	step	step	step	step	step
Segment count time	20 s	20 s	20 s	20 s	40 s	40 s
Measurement period	1/1-12/28	1/1-12/28	1/1-12/28	1/1-12/28	1/1-12/28	1/1-12/28
N (observed)	203	201	84	89	207	200
Average relative bias	+0.479 %	-0.823 %	+1.571 %	+0.257 %	+0.452 %	+0.644 %
Average relative bias	+0.48 %	-0.823 %	+1.57 %	+0.26 %	+0.45 %	+0.64 %
Relative standard deviation	2.975 %	1.955 %	3.107 %	1.595 %	2.258 %	1.254 %
Relative standard deviation	2.98 %	1.96 %	3.11 %	1.60 %	2.26 %	1.25 %

<sup>A</sup> Research Report C26-1007, which contains the above data taken over a one-year period, is available from ASTM Headquarters.

20 to 40 s are used, one standard deviation counting precisions of 5 % or less may be expected.

#### ~~11.3.1 An~~

11.2 An indication that the instrument-calculated estimate of repeatability is reasonable is provided by the following example from actual counting data.<sup>7</sup> Sample statistics for eight consecutive assays of a 208-L drum calibration item, containing 18.09 g <sup>239</sup>Pu in a simulated combustible waste matrix, provide a standard deviation of 0.350 g <sup>239</sup>Pu. The standard deviation, calculated by the measurement program, based on counting statistics, ranged from 0.364 to 0.403 g <sup>239</sup>Pu, with an average value of 0.381 g <sup>239</sup>Pu. Once the precision estimation algorithms have been checked thoroughly, the weekly periodic precision checks and the control charts over long periods should detect any fundamental changes in the validity of the calculated standard deviation estimates.

11.3.2 The measurement data included in Table 2 are provided as an indication of the reproducibility of segmented gamma scan measurements that may be achieved over long periods of time. The items described are calibration items that represent materials typically measured by segmented gamma scan methods. They were prepared to match, as closely as possible, the fundamental material assumptions listed in 1.3, 6.5, and 6.6. The ash standards were characterized by calorimetry and NDA plutonium gamma isotopic measurements. The 30-cm diameter and 208-L waste calibration items were prepared using absorbent material, loaded with known volumes of laboratory-characterized plutonium nitrate solution, and then dried. The data were collected over a period of approximately one year. Measurements of the incinerator ash and combustible waste drums were made on a daily basis and during inventory item assay as part of the routine measurement control program. Measurements of the 30-cm diameter waste containers were made as part of the instrument control program during inventory item assay.

11.4 Bias—The bias of segmented gamma scan measurements depends primarily on the adherence of the measurement assay item to the assumptions of small particle size and homogeneity outlined previously in 1.3, 6.5, 3.6, 6.6, and 6.7. If measurement assay items adhere to these assumptions reliably, little bias is expected in a properly calibrated and controlled measurement system.

11.4.1 Bias contributed to measurements by errors in the knowledge of the mass of SNM contained in calibration items is expected to be negligible compared to total measurement uncertainties for assay items. These uncertainties result from lack of knowledge about SNM distribution and matrix non-uniformities in the assay item and lack of reliable procedures for correcting the biases resulting from non-ideal distributions (see 11.4.2). The effects of uncertainties in the activities of isotopes used for calibration and in the nuclear constants used (half lives and gamma intensities) must be included in the propagation of uncertainty. Activity specifications for line sources from commercial vendors typically have an uncertainty of a few percent (at one standard deviation).

11.4.2 Methods of evaluating the magnitude of biases that are possible due to the failure of real life items to adhere to ideal assumptions are provided in 8.2.4 and 8.2.5. Negative bias will be encountered when the nuclide is present in lumps that attenuate their own radiation to a greater extent than the surrounding material. Positive bias can result from low transmission items with overcorrected end effects. Items containing high-density areas may be biased either high or low or be unbiased, depending on the relative position of the high-density area and the nuclide of interest. In the majority of measurement situations, however, it is expected that measurement results will be lower than true values when biases exist. Measurements Assays of items that do not, or are not known to, adhere to the requirements for SGS measurements defined in 1.3, 6.5, and 3.6, 6.6, and 6.7, must be considered to be of indeterminate accuracy. The factors that tend to bias these measurements (such as variable contents density within a segment and self-attenuating lumps of nuclide material) will probably go undetected and not be accounted for by using the data reduction procedures outlined in this test method.

11.4.3 An analysis of calibration errors provides a basis for estimating the lower limit of the accuracy that can be expected of an analytical method. A published report (14)(20) discussing the analysis of carefully conducted segmented gamma scan calibrations, using well characterized standards of <sup>235</sup>U oxide dispersed in graphite flour, powder, packaged in 10-cm diameter by 28-cm tall metal containers (with <sup>235</sup>U loadings of 15, 85, 155, 225, and 300 g) indicate that two types of situations can affect the ultimate accuracy of a calibration. Item-to-item variations, such as differences in container wall thickness and incorrect characterization of the mass of uranium in each container, cause deviations from a smooth calibration function. Systematic errors, such as inadequately defined attenuation correction factor algorithms in the analysis software, may cause the slope of the calibration function, total corrected count rate per gram <sup>235</sup>U, to be non zero, when a zero slope would be expected based on a perfect implementation of the measurement physics. The calibration data examined gave errors of less than 0.5 % at the extremes of the calibration range. The same report, based on data observed over a period of years, estimates that segmented gamma scan measurements, under the very best conditions, are capable of no better than 1 % accuracy.

11.4.4 The measurement data given in Table 2 provide an indication of the bias and uncertainties that can be obtained during the repetitive measurements of stable items over periods of time ranging from 8 to 12 months. The bias values in Table 2 are for ideal assay samples and represent the best results likely to be obtained using an SGS. Biases for actual assay samples encountered in a process in general will be larger. An indication of bias in routine measurements can be obtained by periodically analyzing assay items by some independent means, such as destructive chemical analysis (135) or, in the case of plutonium-containing items, by coincident neutron counting or calorimetric assay.

11.4.5 Table 3 shows bias results for measurement of <sup>239</sup>Pu in process materials segregated by material description. The

<sup>7</sup> Supporting data are available from ASTM Headquarters. Request RR:C26-1006.

**TABLE 3 Observed Bias and Precision for Measurement of <sup>239</sup>Pu in Process Materials Using Segmented Gamma-Ray Assay**

Material Description	SGS ID	Relative Bias
Small lab crucibles with melted Pu flux in bottom	1	-16.2 %
Mixed ash plus silica and graphite surrogate material	5	0.7 %
	6	-0.9 %
MgO sand from sand, slag, and crucible	2	-4.8 %
	3	-2.9 %
Unpulverized MgO sand and crucible	2	-4.4 %
	3	-2.4 %
Pulverized sand, slag, and crucible	2	-9.5 %
	3	-7.6 %
Unpulverized sand, slag, and crucible	2	-19.1 %
	3	-20.1 %
Caustic waste treatment system oxide	1	-8.2 %
	2	-3.6 %

containers assayed were identical within a category, and were between 2 and 4 liters in volume. Typically fifteen items from a category were used to determine the bias and the standard deviation of its distribution. Reference values were obtained from calorimetric assay of each container. Over broad ranges of radioisotope mass, container size, and matrix density, stream-averaged biases were generally consistent with zero (within  $\pm 20\%$ ). The greater the variability of the assay item characteristics, the greater the variability of the bias on an individual assay. Lump corrections were not used in any of the analyses reported in Table 3 although lump corrections may have reduced the bias in some cases.

11.5 Although simple data handling procedures will probably not correct properly for heterogeneous contents density or lumps of nuclide, careful inspection of the transmission and nuclide peak areas for each segment may provide clues when a measurement should be suspect. Sudden, discontinuous changes in the transmission values for adjacent segments or high nuclide count values for isolated segments are examples of signals indicating possible problem items.

## 12. Keywords

12.1 nondestructive assay; segmented gamma-ray scanning; special nuclear material

## ANNEX

### (Mandatory Information)

#### A1. ERROR PROPAGATION

A1.1 Four types of assay are commonly used in segmented gamma-ray scanning:

A1.1.1 *Three-Peak, One-Pass Assay* —Count-rate correction source peak, transmission source peak, and nuclide of interest peak, all measured with the transmission source shutter open for the entire scan (that is, one-pass).

A1.1.2 *Four-Peak, One-Pass Assay* —Same as in A1.1.1, but with two transmission source peaks (for example, <sup>169</sup>Yb for <sup>235</sup>U assay).

A1.1.3 *Three-Peak, Two-Pass Assay* —Transmission measurements made with the transmission source shutter open, using the count-rate correction source peak and the transmission source peak. Nuclide of interest measurements are made with the shutter closed, using the nuclide of interest peak and the count-rate correction source peak. Two passes, therefore, refer to shutter open and shutter closed data acquisition.

A1.1.4 *Four-Peak, Multi-Peak, Two-Pass Assay* —Same as in A1.1.3, but with ~~two~~ multiple transmission source peaks.

A1.1.5 One-pass assay is used when substantial amounts of the nuclide of interest are present. Two-pass assay, possessing inherently better precision and less bias, is usually used for lower masses of nuclide.

A1.2 Estimates of precision can be calculated in the instrument computer by standard error propagation techniques from the fundamental variances of the peak areas. An estimate of the variance of the mass of the nuclide of interest in an unknown item is usually composed of the estimated variance of the total corrected count rate measured for that item and the contribution from the variance in the calibration constant obtained through least-squares fitting of the set of assays of appropriate physical standards of known nuclide mass.

A1.2.1 Since radioactive decay follows Poisson statistics, the variance in measuring  $N$  events in a detector is  $N$ . The standard deviation is the square root of the variance.

A1.2.2 The fundamental peak areas, if determined by straight-line background subtraction, have the following form:

$$A = P - \left[ \frac{NP}{2} \times \left( \frac{B_1}{NB_1} + \frac{B_2}{NB_2} \right) \right] \quad (\text{A1.1})$$

where:

- $A$  = net peak area (counts),  
 $P$  = total counts in peak region of interest,  
 $NP$  = number of channels summed for  $P$ ,  
 $B_1, B_2$  = total counts in each background region, and  
 $NB_1, NB_2$  = number of channels summed for each background region.

Compare with 10.3.2.

A1.2.3 The corresponding variance of the area  $A$  is given by the following expression (remembering that the variance of  $P = P$ , variance of  $B_1 = B_1$ , and variance of  $B_2 = B_2$ ):

$$\sigma^2(A) = P + \left[ \left( \frac{NP}{2 \times NB_1} \right)^2 \times B_1 \right] + \left[ \left( \frac{NP}{2 \times NB_2} \right)^2 \times B_2 \right] \quad (\text{A1.2})$$

where:

$\sigma(A)$  = standard deviation of peak area  $A$ .

Compare with 10.3.3.

A1.2.4 The variance in a quantity,  $f$ , that is a function of  $n$  independent variables  $x_i$ , is given by the following:

$$\sigma^2(f) = \sum_{i=1}^n \left( \frac{\partial f}{\partial x_i} \right)^2 \sigma^2(x_i) \quad (\text{A1.3})$$

A1.2.5 The mass of the isotope assayed using Isotope Specific (Mass) Calibration is given by the ~~calibration~~ equation:

$$M = \frac{CC - G_0}{G_1} \quad (\text{A1.4})$$

See 10.3.12.

A1.2.65.1 Thus, from Eq A1.3 and Eq A1.4, the variance in the mass is then given by

$$\sigma^2(M) = \frac{\sigma^2(G_0) + \sigma^2(CC) + M^2 \sigma^2(G_1)}{G_1^2} \quad (\text{A1.5})$$

~~For purposes relating to the reproducibility of assaying a given item several times (for example, the precision check, 10.4.7), the precision of the assay, expressed as the relative standard deviation, is given by the following:~~

$$\frac{\sigma(M)}{M} = \frac{\sigma(CC)}{CC} \quad (\text{A1.6})$$

~~which does not include the calibration contribution. Eq A1.5 is often used in addition to Eq A1.6 in the software to show the assayer how calibration, together with assay precision, affects the resultant variability in the mass of the nuclide of interest (assuming no additional biases are known).~~

~~A1.2.6.1 The~~

A1.2.5.2 The coefficients  $G_0$  and  $G_1$  are determined by solving the set of linear equations:

$$\sum_{j=1}^n W_j \times (G_0 + G_1 \times M_j - CC_j) = 0 \quad (\text{A1.6})$$

$$\sum_{j=1}^n W_j \times (G_0 + G_1 \times M_j - CC_j) \times M_j = 0 \quad (\text{A1.7})$$

where:

- $n$  = number of calibration measurements,  
 $M_j$  = known mass of the  $j^{\text{th}}$  standard,  
 $W_j$  =  $1/\sigma^2(CC_j)$  = weight factor, and  
 $\sigma^2(CC_j)$  = variance of total-corrected count rate obtained in the  $j^{\text{th}}$  measurement.

For the preferred case ( $G_0 = 0$ ), there is only one equation to solve:

$$\sum_{j=1}^n W_j \times (G_1 \times M_j - CC_j) \times M_j = 0 \quad (\text{A1.8})$$

A1.2.65.23 The variances of  $G_0$  and  $G_1$  are given by

$$\sigma^2(G_0) = \frac{\sum_{j=1}^n W_j \times M_j^2}{\left( \sum_{j=1}^n W_j \right) \times \left( \sum_{j=1}^n W_j \times M_j^2 \right) - \left( \sum_{j=1}^n W_j \times M_j \right)^2} \quad (\text{A1.9})$$

$$\sigma^2(G_1) = \frac{\sum_{j=1}^n W_j}{\left(\sum_{j=1}^n W_j\right) \times \left(\sum_{j=1}^n W_j \times M_j^2\right) - \left(\sum_{j=1}^n W_j \times M_j\right)^2} \quad (\text{A1.10})$$

For the preferred case ( $G_0 = 0$ ), there is only one equation to solve:

$$\sigma^2(G_0) = 0 \quad (\text{A1.11})$$

$$\sigma^2(G_1) = \frac{1}{\sum_{j=1}^n W_j \times M_j^2} \quad (\text{A1.12})$$

Eq A1.10 A1.9 through Eq A1.132 assume that the masses ( $M_j$ ) of the SNM in the standard reference materials are exact. This is a reasonable approximation because the uncertainties in mass from chemical fabrication and chemical analysis of the standards are usually much smaller than the precisions obtained on the segmented gamma-ray scanner, assuming reasonable assay times when making the  $n$  measurements of the standards during calibration.

A1.2.6 The mass of an isotope assayed using an Efficiency Curve Calibration is given by the equation:

$$M(\text{Iso}, E_\gamma) = \frac{1}{SA(\text{Iso}) \times I_\gamma(\text{Iso}, E_\gamma)} \times \sum_{i=1}^N \frac{CC(E_\gamma)_i}{\epsilon(E_\gamma)_i} \quad (\text{A1.13})$$

A1.2.6.1 From Eq A1.3 and Eq A1.13, the variance of the mass of isotope Iso is given by:

$$\sigma^2(M(\text{Iso})) = M^2(\text{Iso}) \times \quad (\text{A1.14})$$

$$\sum_{i=1}^N \left[ \frac{\sigma^2(CC(E_\gamma)_i)}{CC^2(E_\gamma)_i} + \frac{\sigma^2(\epsilon(E_\gamma)_i)}{\epsilon^2(E_\gamma)_i} \right] + \frac{\sigma^2(SA(\text{Iso}))}{SA^2(\text{Iso})} + \frac{\sigma^2(I_\gamma(\text{Iso}, E_\gamma))}{I_\gamma^2(\text{Iso}, E_\gamma)}$$

A1.2.6.2 Each efficiency function  $\epsilon(E_\gamma)_i$  can be represented by a polynomial or a linear combination of analytic functions and is specified by several coefficients. These coefficients are determined by fitting the efficiency function to a set of efficiency values over a range of energies  $\{\epsilon(E_\gamma)_i\}$ , where each  $\epsilon(E_\gamma)_i$  value is determined from segment count data from a line source standard emitting multiple energies using the equation:

$$\epsilon(E_\gamma)_i = \frac{CC(E_\gamma)_i}{A(\text{CIso})_i \times I_\gamma(\text{CIso}, E_\gamma)} \quad (\text{A1.15})$$

where:

$\epsilon(E_\gamma)_i$  = efficiency of the detector for material in segment  $i$  for gammas of energy  $E_\gamma$ .

$CC(E_\gamma)_i$  = corrected count rate of peak at energy  $E_\gamma$ .

$A(\text{CIso})_i$  = activity (Becquerels) of calibration radioisotope  $\text{CIso}$  in segment  $i$ , and

$I_\gamma(\text{CIso}, E_\gamma)$  = intensity of gamma ray of energy  $E_\gamma$  from calibration radioisotope  $\text{CIso}$ .

A1.2.6.3 The uncertainties in nuclear data constants (specific activities and gamma intensities) are generally reported with the data values.

A1.2.6.4 There are other valid methods for calculation of the detector efficiency values.

A1.2.7 For purposes relating to the reproducibility of assaying a given item several times (for example, the precision check, 10.4.7), the precision of the assay, expressed as the relative standard deviation, is given by the following:

$$\frac{\sigma(M)}{M} = \frac{\sigma(CC)}{CC} \quad (\text{A1.16})$$

which does not include the calibration contribution. The uncertainty results from Eq A1.15 or Eq A1.14 may be displayed by the software in addition to those from Eq A1.16 to show how calibration, together with assay precision, affects the resultant variability in the mass of the nuclide of interest.

A1.2.8 The variance of  $CC$ , the total-corrected count rate, is the sum of the variances of  $CC_i$ , the corrected count rate at segment  $i$ .

A1.3 The variance of each  $CC_i$  is computed from the peak areas for the nuclide of interest, transmission source, and count-rate correction source. In the following, the values of the count-rate correction source peak area and the transmission source peak areas measured in background runs, whether single or double pass, are assumed to have negligible random error since they should be measured to a high precision each day. Also, measurement of the empty container transmission should be highly precise, so that its random error can be neglected. The expressions for the corrected count rates for a segment and the variances of the corrected count rates for the four assay types follow:

$$CC_i = (A_i/t) \times (CFRL) \times CF_i(T_i') \times CF_{\text{can}} \quad (\text{A1.17})$$

$$CFRL = LT_0/LT_i \quad (\text{A1.18})$$

$$CF_i(T_i') = \frac{-B \times \ln(T_i')}{1 - (T_i')^B} \quad (\text{A1.19})$$

$$CF_{\text{can}} = \frac{1}{(T_c)^{1/2}} \quad (\text{A1.20})$$

where:

- $A_i$  = assay isotope peak area measured at segment  $i$  (obtained from Eq A1.1),
- $t$  = total true time to accumulate  $A_i$ ,
- $CFRL$  = correction factor for rate-related losses due to deadtime and pileup,
- $LT_o$  = peak area of the count-rate correction source measured with no other sources present (that is, during the background run with the shutter closed) normalized to a collection time equal to that of  $A_i$ ,
- $LT_i$  = peak area of the count-rate correction source measured simultaneously with  $A_i$ ,
- $CF_i(T_i')$  = correction factor for attenuation (CFAT) due to the material inside the container of the assay item,
- $B$  = geometric parameter (typically 0.7 to 0.823 for cylinders),
- $T_i'$  = transmission of the material within the container at the nuclide's gamma-ray energy,
- $CF_{\text{can}}$  = correction factor for attenuation due to the walls of the container, and
- $T_c$  = transmission of the empty container at the nuclide's gamma-ray energy.

A1.3.1 For Eq A1.218 through Eq A1.358, the subscript notations will be the following:

where:

- b = background measurements, no sample present,
- o = measurements made with the transmission source shutter open,
- c = measurements made with the transmission source shutter closed,
- l = low energy transmission peak, and
- h = high energy transmission peak.

A1.3.1.1 For one-pass assays:

$$A_i = A_o \quad (\text{A1.21})$$

where:

$A$  = nuclide of interest peak area.

$$CFRL = LT_o/LT_i = L_{bc}/L_o \quad (\text{A1.22})$$

where:

$L$  = count rate correction source peak area.

For three-peak assay and  $\mu_A/\mu_T \approx 1$ :

$$TR = T_i' = \frac{T_o}{T_{bo}} \times \frac{L_{bo}}{L_o} \times CF_{\text{can}}^2 \quad (\text{A1.23})$$

For four-peak assay  $^{235}\text{U}$  assay (see 10.3.7) using  $^{169}\text{Yb}$  as a transmission source:

$$TR = T_i' = 0.6 (TR_l) + 0.4 (TR_h) \quad (\text{A1.24})$$

where:

$T$  = transmission source peak area.

$$TR_l = \left( \frac{T_o}{T_{bo}} \right)_l \times \frac{L_{bo}}{L_o} \times CF_{\text{can}}^2 \quad (\text{A1.25})$$

$$TR_h = \left( \frac{T_o}{T_{bo}} \right)_h \times \frac{L_{bo}}{L_o} \times CF_{\text{can}}^2 \quad (\text{A1.26})$$

A1.3.1.2 For two-pass assays:

$$A_i = A_c \quad (\text{A1.27})$$

$$CFRL = LT_o/LT_i = L_{bc}/L_c \quad (\text{A1.28})$$

For three-peak assay and  $\mu_A/\mu_T \approx 1$ :

$$TR = T_i' = \frac{T_o}{T_{bo}} \times \frac{L_{bo}}{L_o} \times CF_{\text{can}}^2 \quad (\text{A1.29})$$

For four-peak  $^{235}\text{U}$  assay (see 10.3.7):

$$TR = T_i' = (0.6) TR_l + (0.4) TR_h \quad (\text{A1.30})$$

where:

$$TR_l = \left( \frac{T_o}{T_{bo}} \right)_l \times \frac{L_{bo}}{L_o} \times CF_{\text{can}}^2 \quad (\text{A1.31})$$

$$TR_h = \left( \frac{T_o}{T_{bo}} \right)_h \times \frac{L_{bo}}{L_o} \times CF_{can}^2 \quad (A1.32)$$

A1.3.1.3 The relative standard deviation is defined as follows:

$$\sigma_r(V) = \sigma(V)/V$$

$$\sigma_r(V) = \sigma(V)/V \quad (A1.33)$$

and introduce the factor,  $K$ , present in all of the variances to follow:

$$K = \frac{B}{CFAT} \times \frac{(1 - TR^B \times CFAT)}{1 - (TR)^B} \quad (A1.34)$$

where:

$CFAT = CF_i(T_i')$ , and

$T_i' = TR$ .

A1.3.1.4 The variances for each segment as functions of the measured peak areas become the following:

For three-peak, one-pass assay:

$$\sigma^2(CC_i) = CC_i^2 \times [\sigma_r^2(A_o) + K^2 \times \sigma_r^2(T_o) + (1 - K)^2 \times \sigma_r^2(L_o)] \quad (A1.35)$$

For three-peak, two-pass assay:

$$\sigma^2(CC_i) = CC_i^2 \times \{\sigma_r^2(A_o) + \sigma_r^2(L_o) + K^2[\sigma_r^2(T_o) + \sigma_r^2(L_o)]\} \quad (A1.36)$$

For four-peak, one-pass assay:

$$\sigma^2(CC_i) = CC_i^2 \times \{\sigma_r^2(A_o) + K^2 \times \left[ \left( \frac{0.6TR_1}{TR} \right)^2 \times \sigma_r^2(T_{ol}) + \left( \frac{0.4TR_h}{TR} \right)^2 \times \sigma_r^2(T_{oh}) \right] + (1 - K)^2 \times \sigma_r^2(L_o)\} \quad (A1.37)$$

For four-peak, two-pass assay:

$$\sigma^2(CC_i) = CC_i^2 \times \{\sigma_r^2(A_o) + \sigma_r^2(L_o) + K^2 \times \left[ \left( \frac{0.6TR_1}{TR} \right)^2 \times \sigma_r^2(T_{ol}) + \left( \frac{0.4TR_h}{TR} \right)^2 \times \sigma_r^2(T_{oh}) + \sigma_r^2(L_o) \right]\} \quad (A1.38)$$

$$\sigma^2(CC_i) = CC_i^2 \times \{\sigma_r^2(A_o) + \sigma_r^2(L_o) + K^2 \times \left[ \left( \frac{0.6TR_1}{TR} \right)^2 \times \sigma_r^2(T_{ol}) + \left( \frac{0.4TR_h}{TR} \right)^2 \times \sigma_r^2(T_{oh}) + \sigma_r^2(L_o) \right]\} \quad (A1.38)$$

NOTE A1.1—For  $0.1 \leq TR \leq 0.7$ ,  $K$  varies slowly:  $0.29 \leq K \leq 0.39$ .

A1.3.1.5 If the assay and transmission energies in the three-peak case are sufficiently different to invalidate the assumption  $\mu_A \approx \mu_T$ , then replace  $B$ , the geometric factor in  $CFAT$ , with  $B \times KA$ , where  $KA = \mu_A/\mu_T$ . Notice that  $B$  is part of  $K$  in the variance equations, so  $B \times KA$  would need to replace  $B$  in the  $K$  value also.

**REFERENCES**

- (1) Martin, E. R., Jones, D. F., and Parker, J. L., "Gamma-Ray Measurements with the Segmented Gamma Scan," LA-7059-M, Los Alamos Scientific Laboratory, 1977.
- (2) Reilly, T. D., and Parker, J. L., "A Guide to Gamma-Ray Assay for Nuclear Materials Accountability," LA-5794-M, Los Alamos Scientific Laboratory, 1975.
- (3) Parker, J. L., Reilly, T. D., Walton, R. B., Smith, D. B., and East, L. V., "Attenuation-Corrected Passive Gamma Assay," LA-4705-MS, Los Alamos Scientific Laboratory, 1971.
- (4) Parker, J. L., and Reilly, T. D., "Transmission Measurement Correction for Self-Attenuation in Gamma-Ray Assays of Special Nuclear Material," *Nuclear Materials Management*, Vol V, No. 2, 1976, pp. 58-67.
- (5) Parker, J. L., "The Use of Calibration Standards and the Correction for Sample Self-Attenuation in Gamma-Ray Nondestructive Assay," LA-10045, Revision, Los Alamos National Laboratory, 1984.
- (6) Parker, J. L., "A Correction for Gamma-Ray Self Attenuation in Regular Heterogeneous Materials," LA-8987-MS, Los Alamos National Laboratory, 1981.
- (7) Sprinkle, J. K., Jr., and Hsue, S.-T., "Recent Advances in Segmented Gamma Scanner Analysis," LA-UR-87-3954, Los Alamos National Laboratory, 1987.
- (8) Simmonds, S. M., et al, "Nondestructive Assay of Plutonium Bearing Scrap and Waste with the Advanced Segmented Gamma-Ray Scanner," *31st Annual Meeting Proceedings*, Vol XIX, Institute of Nuclear Materials Management, Northbrook, IL, 1990, pp. 421-425.
- (9) Estep, R. E., "Assay of Heterogeneous Radioactive Wastes by Low-Resolution Tomographic Gamma Scanning," LA-UR-90-2054, Los Alamos National Laboratory, 1990.
- (10) Estep, R. E., and Sherwood, K. B., "A Prototype Tomographic Gamma Scanner for Assaying 208-L Drums," LA-UR-91-61, Los Alamos National Laboratory, 1991.
- (11) ~~Wick, O. J., ed., Schanfein, M., et al., "Performance Validation of Commercially Available Mobile Waste Assay Systems: Preliminary Report," *Plutonium Handbook*, Vol II, Gordon and Breach Science Publishers, New York, NY, 1967. Waste Characterization Conference, Salt Lake City, January 14-16, 1997.~~
- (12) ~~Jeter, I. W., et al., "Application of NDA Instrumentation Gamma-rays Produced in the Y-12 Highly Enriched Uranium Recovery Facility," Y/DG-14880, Oak Ridge National Laboratory, 1981. Spherical Sources," *Nuclear Geophysics*, Vol 9, No 5, 1995, pp. 425-430.~~
- (13) ~~Fleissner, J. G., Reilly, D., Ensslin, N., and Hume, M. W., "A Comparison of Destructive and Nondestructive Assay of Heterogeneous Salt Residues," RFP-3876, Rocky Flats Plant, 1986. Nuclear Materials, LA-UR-90-732, Los Alamos National Laboratory, 1991, pp. 178-180.~~
- (14) ~~Jeter, I. W., et al., "Application of NDA Instrumentation in the Y-12 Highly Enriched Uranium Recovery Facility," Y/DG-14880, Oak Ridge National Laboratory, 1981.~~
- (15) Fleissner, J. G., and Hume, M. W., "A Comparison of Destructive and Nondestructive Assay of Heterogeneous Salt Residues," RFP-3876, Rocky Flats Plant, 1986.
- (16) Fleissner, J. G., Baldwin, C. E., and Franco, J. B., "Upgrade and Calibration of a Segmented Gamma Scan Drum Counter at Rocky Flats," *Proceedings of the 6th Nondestructive Assay and Waste Characterization Conference*, Salt Lake City, November 1998.
- (17) Bruggeman, M., Gertis, J., and Carchon, R., "A Minimum Biased Shell-source Method for the Calibration of Rad Waste Assay Systems," *Applied Radiation and Isotopes*, Vol 51, 1999, pp. 255-259.
- (18) Wick, O. J., ed., *Plutonium Handbook*, Vol II, Gordon and Breach Science Publishers, New York, NY, 1967.
- (19) Thomason, R.S., and Croft, S., "Computational Study of the Accuracy of the Material Basis Set Method for Transmission Data Interpolation," Abstract No. 143, 44th Annual Meeting Proceedings, Institute of Nuclear Materials Management, Northbrook, IL, 2003
- (20) Sampson, T. E., and Goldman, A., "Analysis of NDA Instrument Calibration Data," LA-11316-MS, Los Alamos National Laboratory, 1988.

ASTM International takes no position respecting the validity of any patent rights asserted in connection with any item mentioned in this standard. Users of this standard are expressly advised that determination of the validity of any such patent rights, and the risk of infringement of such rights, are entirely their own responsibility.

This standard is subject to revision at any time by the responsible technical committee and must be reviewed every five years and if not revised, either reapproved or withdrawn. Your comments are invited either for revision of this standard or for additional standards and should be addressed to ASTM International Headquarters. Your comments will receive careful consideration at a meeting of the responsible technical committee, which you may attend. If you feel that your comments have not received a fair hearing you should make your views known to the ASTM Committee on Standards, at the address shown below.

This standard is copyrighted by ASTM International, 100 Barr Harbor Drive, PO Box C700, West Conshohocken, PA 19428-2959, United States. Individual reprints (single or multiple copies) of this standard may be obtained by contacting ASTM at the above address or at 610-832-9585 (phone), 610-832-9555 (fax), or service@astm.org (e-mail); or through the ASTM website (www.astm.org).