



Standard Test Method for Nondestructive Analysis of Special Nuclear Materials in Homogeneous Solutions by Gamma-Ray Spectrometry¹

This standard is issued under the fixed designation C 1221; the number immediately following the designation indicates the year of original adoption or, in the case of revision, the year of last revision. A number in parentheses indicates the year of last reapproval. A superscript epsilon (ϵ) indicates an editorial change since the last revision or reapproval.

1. Scope

1.1 This test method is applicable to the determination of the concentration of gamma-ray emitting special nuclear materials dissolved in homogeneous solutions. The test method corrects for gamma-ray attenuation by the sample and its container by measurement of the transmission of a beam of gamma rays from an external source (Refs. (1), (2), and (3)).²

1.2 Two sample geometries, slab and cylinder, are considered. The sample container that determines the geometry may be either a removable or a fixed geometry container. This test method is limited to sample containers having walls or a top and bottom of equal transmission through which the gamma rays from the external transmission correction source must pass.

1.3 This test method is typically applied to radionuclide concentrations ranging from a few mg/L to several hundred g/L. The assay range will be a function of the specific activity of the nuclide of interest, the physical characteristics of the sample container, counting equipment considerations, assay gamma-ray energies, sample matrix, gamma-ray branching ratios, and interferences.

1.4 *This standard does not purport to address all of the safety problems, if any, associated with its use. It is the responsibility of the user of this standard to establish appropriate safety and health practices and determine the applicability of regulatory limitations prior to use.* For specific hazards, see Section 9.

2. Referenced Documents

2.1 ASTM Standards:

- C 859 Terminology Relating to Nuclear Materials³
- C 982 Guide for Selecting Components for Energy Dispersive X-Ray Fluorescence (XRF) Systems³
- C 1133 Test Method for Nondestructive Assay of Special Nuclear Material in Low Density Scrap and Waste by Segmented Passive Gamma-Ray Scanning³
- C 1168 Practice for Preparation and Dissolution of Plu-

onium Materials for Analysis³

E 181 General Methods for Detector Calibration and Analysis of Radionuclides⁴

2.2 ANSI Standards:

ANSI N15.20 Guide to Calibrating Nondestructive Assay Systems⁵

ANSI N15.35 Guide to Preparing Calibration Material for Nondestructive Assay Systems that Count Passive Gamma Rays⁵

ANSI N15.37 Guide to the Automation of Nondestructive Assay Systems for Nuclear Material Control⁵

ANSI/IEEE 645 Test Procedures for High-Purity Germanium Detectors for Ionizing Radiation⁵

2.3 U.S. Nuclear Regulatory Commission Regulatory Guides:

Regulatory Guide 5.9, Rev. 2, Guidelines for Germanium Spectroscopy Systems for Measurement of Special Nuclear Materials⁶

Regulatory Guide 5.53, Rev. 1, Qualification, Calibration, and Error Estimation Methods for Nondestructive Assay⁶

3. Terminology

3.1 For definitions of terms used in this test method, refer to Terminology C 859.

4. Summary of Test Method

4.1 Many nuclear materials spontaneously emit gamma rays with energies and intensities characteristic of the decaying nuclide. The analysis for these nuclear materials is accomplished by selecting appropriate gamma rays and measuring their intensity to identify and quantify the nuclide.

4.1.1 The gamma-ray spectrum of a portion of solution is obtained with a collimated, high resolution gamma-ray detector.

4.1.2 Count-rate-dependent losses are determined and corrections are made for these losses.

4.1.3 A correction factor for gamma-ray attenuation in the sample and its container is determined from the measurement of the transmitted intensity of an external gamma-ray source. The gamma rays from the external source have energies close

¹ This test method is under the jurisdiction of ASTM Committee C-26 on Nuclear Fuel Cycle and is the direct responsibility of Subcommittee C26.10 on Non-Destructive Assay.

Current edition approved Nov. 15, 1992. Published July 1993.

² The boldface numbers in parentheses refer to the list of references at the end of this test method.

³ *Annual Book of ASTM Standards*, Vol 12.01.

⁴ *Annual Book of ASTM Standards*, Vol 12.02.

⁵ Available from American National Standards Institute, 11 W. 42nd St., 13th Fl., New York, NY 10036.

⁶ Available from U.S. Nuclear Regulatory Commission, Washington, DC 20555.

to those of the assay gamma rays emitted from the sample. Figs. 1 and 2 illustrate typical transmission source, sample, and detector configurations. Gamma rays useful for assays of ^{235}U and ^{239}Pu are listed in Table 1.

4.1.4 The relationship between the measured gamma-ray intensity and the nuclide concentration (the calibration constant) is determined by use of appropriate standards (ANSI N15.20, ANSI N15.35, USNRC Regulatory Guide 5.53, Rev. 1).

4.2 In the event that the total element concentration is desired and only one isotope of an element is determined (for example, ^{239}Pu), the isotopic ratios must be measured or estimated.

5. Significance and Use

5.1 This test method is a nondestructive means of determining the nuclide concentration of a solution for special nuclear material accountancy, nuclear safety, and process control.

5.2 It is assumed that the nuclide to be analyzed is in a homogeneous solution (Practice C 1168).

5.3 The transmission correction makes the test method independent of matrix and useful over several orders of magnitude of nuclide concentrations. However, a typical configuration will normally span only two to three orders of magnitude.

5.4 The test method assumes that the sample-detector geometry is the same for all measured items. This can be accomplished by requiring that the liquid height in the side-looking geometry exceeds the detector field of view defined by the collimator. For the uplooking geometry, a fixed sample fill height must be maintained and vials of identical radii must be used unless the vial radius exceeds the field of view defined by the collimator.

5.5 Since gamma-ray systems can be automated, the test method can be rapid, reliable and not labor intensive.

5.6 This test method may be applicable to in-line or off-line situations.

6. Interferences

6.1 Radionuclides may be present in the sample which produce gamma rays with energies that are the same or very nearly the same as the gamma rays suggested for nuclide measurement, count rate correction, or transmission correction.

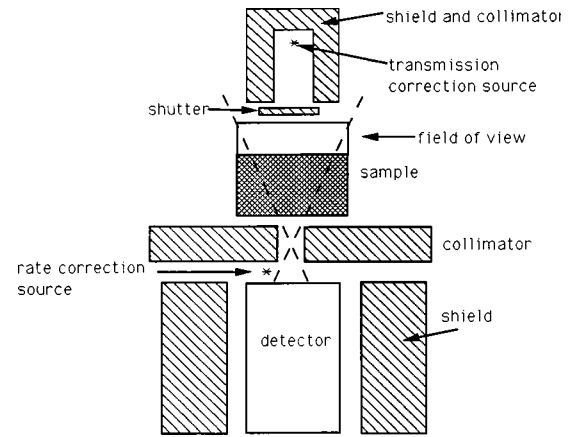

NOTE 1—The sample geometry in this case is a slab. (Not to scale.)
FIG. 2 Schematic of an Uplooking Configuration

TABLE 1 Suggested Nuclide/Source Combinations

Nuclide	Peak Energy (keV)	Transmission Source	Peak Energy (keV)	Count Rate Correction Source	Peak Energy (keV)
^{235}U	185.7	^{169}Yb	177.2	^{241}Am	59.5
			198.0		
^{239}Pu	413.7	^{75}Se	400.1	^{133}Ba	356.3
^{239}Pu	129.3	^{57}Co	122.1	^{109}Cd	88.0
			136.5		

Thus, the corresponding peaks in the gamma-ray spectrum may be unresolved and their areas may not be easily determined unless multiplet fitting techniques are used. In some cases the nuclide of interest may emit other gamma rays which can be used for analysis or alternative transmission or count rate correction sources may be used.

6.1.1 Occasionally, a significant amount of ^{237}Np is found in a plutonium sample. The ^{237}Np daughter, ^{233}Pa , emits a gamma ray at 415.8 keV as well as other gamma rays in the 300 to 400 keV region. These ^{233}Pa gamma rays may interfere with the analysis of ^{239}Pu at 413.7 keV and at several other normally useful ^{239}Pu gamma-ray energies. In this case, the ^{239}Pu gamma ray at 129.3 keV may be a reasonable alternative. In addition, the 398.7 keV gamma ray from ^{233}Pa may interfere with the transmission corrections based on the 400.7 keV ^{75}Se gamma-ray measurements. Multiplet fitting techniques can resolve these problems.

6.1.2 ^{169}Yb , used as the transmission source for ^{235}U assays, emits a 63.1 keV gamma ray which may interfere with the measurement of the area of the peak produced by the 59.5 keV gamma ray of ^{241}Am , which is commonly used as the count rate correction source. The 63.1 keV ^{169}Yb gamma ray should be attenuated by placing a cadmium absorber over the transmission source. ^{109}Cd may be a suitable alternative count rate correction source.

6.1.3 In the special case of ^{239}Pu assays using ^{75}Se as a transmission source, random coincident summing of the 136.0 and 279.5 keV gamma-ray emissions from ^{75}Se produces a low intensity sum peak at 415.5 keV that interferes with the peak area calculation for the peak produced by the 413.7 keV gamma ray from ^{239}Pu . The effects of this sum peak interference can be reduced by using absorbers to attenuate the

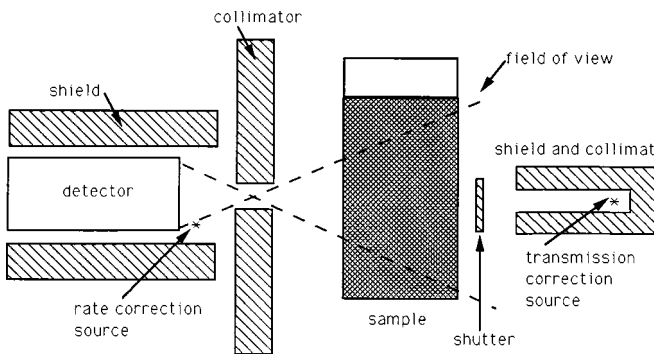

NOTE 1—The sample geometry may be either cylindrical or a slab. (Not to scale.)

FIG. 1 Schematic of a Sidelooking Configuration

radiation from the ^{75}Se to the lowest intensity required for transmission measurements of acceptable precision. The problem can be avoided entirely by making two separate measurements on each sample; first, measure the peak area of the transmission source with the sample in place and second, measure the peak area of the assay gamma ray while the detector is shielded from the transmission source.

6.1.4 In ^{239}Pu solutions with high activities of ^{241}Am or ^{237}U , or both, the Compton continuum from intense 208.0 keV gamma rays may make the 129.3 keV gamma ray from ^{239}Pu unusable for assays. Also, the 416.0 keV sum peak that results from pileup of the 208.0 keV gamma rays may interfere with the 413.7 keV gamma ray from ^{239}Pu . Use an absorber (for example, 0.5 to 0.8 mm of tungsten) between the detector and sample to attenuate the 208.0 keV gamma rays. This will attenuate the intensity of the lower energy gamma rays and also reduce the sum peak interference. The resulting ^{239}Pu assay will be based on the 413.7 keV gamma ray.

6.1.5 X-rays of approximately 88 keV from lead in the shielding may interfere with the measurement of the 88.0 keV gamma-ray peak when ^{109}Cd is used as the count rate correction source. Graded shielding (4) is required to remove the interference.

6.2 Peaks may appear in the spectrum at gamma-ray energies used for analysis when there is no sample present. This may be caused by excessive amounts of radioactive material stored in the vicinity of the detector or by contamination of the instrument. This can cause variable and unacceptably high backgrounds leading to poor measurement quality.

6.2.1 Remove unnecessary radioactive material from the vicinity and also restrain movement of radioactive material around the assay area during measurements. Shielding should be provided that completely surrounds the detector with the exception of the collimator opening. Shielding opposite the detector on the far side of the sample will also reduce the amount of ambient radiation incident on the detector.

6.2.2 Use sample containers that are free of outer surface contamination. Remove any contamination from the instrument which may interfere with analyses. It may not be possible to completely decontaminate in-line instrumentation. In this case the contamination should be minimized to the extent practical.

6.2.3 The measurement of background should be made at various times during the day. Varying backgrounds can be caused by process activities which often occur on regular schedules. These time-dependent backgrounds might not be detected if the background is checked at the same time each day.

6.3 High energy gamma rays from fission products in the sample will increase the Compton background and decrease the precision of gamma-ray intensity measurements in the lower energy (<500 keV) region of the spectrum.

6.4 Low energy X- and gamma rays from either the transmission or count rate correction source may contribute significantly to the total system electronic pulse rate causing increased count rate losses and sum peak interferences. An absorber should be fixed between the source and detector to reduce the number of low energy X-rays detected.

7. Apparatus

7.1 General guidelines for selection of detectors and signal-processing electronics are discussed in Guide C 982 and NRC Regulatory Guide 5.9, Rev. 2. Data acquisition systems are considered in ANSI N15.37 and NRC Regulatory Guide 5.9, Rev. 2. It is recommended that the system have the following components:

7.1.1 *High Resolution, Germanium, Gamma-Ray Detector*—A coaxial-type detector with full width at half maximum (FWHM) resolution typically less than 850 keV at 122 keV and less than 2.0 keV at 1333 keV may be used for the analysis. A planar-type detector with resolution typically less than 600 keV FWHM at 122 keV may also be used. The stated resolutions are for guidance only. The selection of detector type, coaxial or planar, should be based on the usual considerations of efficiency and resolution required for the specific application. Test procedures for detectors are given in Method E 181 and ANSI/IEEE 645.

7.1.2 *Nuclear Spectroscopy Amplifier*—The amplifier capabilities should include selectable pulse shaping time constants, pole zero adjustment, active gated baseline restoration, and pulse pileup rejection. A discussion of these functions is found in Guide C 982.

7.1.3 *Oscilloscope*, required for proper adjustment of the various amplifier controls and troubleshooting the electronics. The oscilloscope should have selectable time bases ranging from 1 ms/cm to 0.5 $\mu\text{s}/\text{cm}$ (20 MHz) and selectable vertical sensitivities ranging from 5 V/cm to 10 mV/cm.

7.1.4 *High Voltage Bias Supply*, equipped with continuously adjustable voltage control with a voltage range compatible with the requirements of the above detector.

7.1.5 *Count-Rate Meter*, to monitor the total electronic pulse rate in the system for acceptable rate. It should be compatible with the output of the above amplifier.

7.1.6 *Multichannel Analyzer (MCA)*—An MCA with a minimum of 4096 data channels is recommended. The analyzer should operate using a Wilkinson type analog-to-digital converter (ADC) with a minimum ADC clock rate of 100 MHz, or a fixed conversion time ADC with a maximum conversion time of 10 μs . Anti-coincidence gating for pulse-pile-up rejection, compatible with the above amplifier, and signal level discrimination may be required. Analyzer control, data transfer, and data analysis by computer are recommended. Spectrum display may be provided by the analyzer or computer.

7.1.7 *Digital Spectrum Stabilizer*—The stabilizer monitors two separate gamma rays, one at low energy and one at high energy, to control changes in both zero intercept and energy gain. The stabilizer must be compatible with the ADC/MCA combination described in 7.1.6. The peaks chosen for stabilization must be present in every spectrum. Instead of selecting gamma rays for stabilization, a pulser may be used with the spectrum stabilizer. However, when using a pulser proper precautions must be taken to eliminate added spectral distortions (5).

7.1.8 *Computer System*, equipped with sufficient random access memory, disk storage, printer, and terminal is recommended for system control, data reduction, report generation, and operator interface.

7.2 *Detector Collimator*—The collimator defines the field of view of the detector to a reproducible sample geometry and shields the detector from ambient radiation. This test method addresses two potential sample/collimator geometries that will dictate the analytical expression used.

7.2.1 The collimator in the slab geometry (both uplooking and sidelooking) is a cylindrical hole with its axis normal to the slab. The diameter of the collimator should limit the field of view of the detector to within the sample volume (see Fig. 1 and Fig. 2).

7.2.2 The collimator in the cylindrical geometry should be a slit perpendicular to the axis of the sample. The field of view in this case is within the sample volume in the axial direction (see Fig. 1) and includes the entire sample volume in the radial direction (Fig. 3).

7.3 *Count Rate Correction Source*—To minimize interferences, the source should be chosen to have gamma-ray energies lower than the gamma rays of interest. The source must be fixed relative to the detector, and its beam relative to the detector must not be attenuated by the sample. See Table 1 for suggested gamma-ray sources.

7.4 *Transmission Source*—The transmission source should preferably emit gamma rays that bracket the energy of the assay gamma ray from the nuclide of interest. A single gamma ray with an energy near the assay gamma ray may be used. Table 1 provides a list of suggested nuclides for use as transmission sources with nuclides of interest. The source activity should typically be a few tens of millicuries. Where a two-measurement assay (as described in 6.1.3) will be used, construct the instrument such that the detector can be shielded from the transmission source during measurement of the assay gamma rays. A computer controlled shutter between the transmission source and sample is ideal for this purpose in an automated system. The transmission source should be placed opposite the detector and shine through the aperture of the detector collimator as illustrated in Fig. 1. The transmission source should shine through the diameter of the sample container in the cylindrical geometry.

7.5 *Absorber Foils*—Absorbers are used to reduce the overall count rate due to low energy X-rays and gamma rays from the sample, transmission source, and count rate correction

source. The absorbers are usually cadmium or copper, or both. Any change of these absorbers requires recalibration of the assay system.

7.6 *Sample Holder*—The sample holder must provide repeatable placement of the sample container between the detector and transmission source.

7.7 *Sample Container*, either a removable sample vial with reproducible gamma-ray path length and wall thickness or a fixed-path-length flow-through cell. Low atomic number material should be used in container production to reduce absorption of assay gamma-rays. The equations presented in this test method apply only to sample containers with walls or a top and bottom of equal transmission for the cylindrical and slab geometry configurations, respectively.

8. Reference Materials

8.1 Calibration of the assay system involves using a set of standards to determine the relationship between the observed, corrected count rate of the characteristic gamma ray of a nuclide and the concentration of the nuclide known to be present. After correcting for background, rate-related losses, and attenuation effects, a direct proportionality constant is determined between count rate and nuclide concentration.

8.2 Prepare at least three calibration standards for each nuclide to be assayed. Standards should span the expected concentration range of samples. The use of three calibration standards will verify the validity of the transmission correction and the linearity of the instrument. More than three standards may be required if the instrument covers a wide concentration range.

8.2.1 The standards should be certified to contain a known nuclide concentration by an alternative technique traceable to certified reference materials.

8.2.2 Standards should be in a matrix providing transmissions similar to those expected for samples and be in the same container geometry to be used for sample assays.

9. Hazards

9.1 Safety:

9.1.1 Transuranic materials are both radioactive and toxic. Adequate laboratory facilities and safe operating procedures must be considered to protect operators from both unnecessary exposure to ionizing radiation and from contamination while handling measurement items.

9.1.2 The recommended analytical procedures call for the use of radioactive sources, some with high levels of ionizing radiation. Consult a qualified health physicist or radiation safety professional concerning exposure problems and leak test requirements before handling radioactive sources.

9.2 Technical:

9.2.1 Prevent counting conditions that may produce spectral distortions.

9.2.1.1 High count rates can cause electronic pulse pileup resulting in peak shape distortion and sum peaks in the spectrum. Pulse pileup rejection circuitry should be used to prevent this. When appropriate, use absorbers to reduce the intensity of low energy X-rays and gamma rays.

9.2.1.2 Changing temperature and humidity in the measurement environment may cause gain and zero-level shifts of the

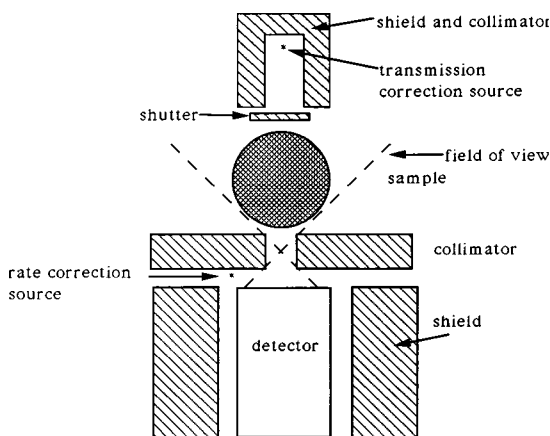

NOTE 1—Not to scale.

FIG. 3 Axial View of a Cylindrical Sample Geometry

gamma-ray spectrum. Employ environmental controls or digital stabilization to minimize shifts.

9.2.1.3 Failure to isolate electronic components from other electrical equipment may cause noise pickup in the high voltage and signal cables leading to spectral distortions. Noise in the AC power supply will also produce spectral distortions.

9.2.2 Locate the instrument in an area with as low a gamma-ray background as practical. Prohibit the movement of containers of radioactive material in the vicinity of the instrument while an assay is underway.

9.2.3 Keep the instrument, and especially the sample holder and detector, as free of radioactive contamination as practical. This contamination causes an increase in background counts which decreases the signal to noise ratio in analysis and causes biases if not corrected.

9.2.4 Minimize the exposure of the detector to neutrons by not storing neutron emitting samples or sources on or near the detector. Leave samples in the sample holder only as long as is required for measurement.

10. Preparation of Apparatus

10.1 Adjust instrument settings in accordance with manufacturers' instructions and good spectroscopic practices.

10.2 Choose collimator and sample holder size to define geometry such that a fixed volume of sample is viewed. Refs. (3) and (6) provide guidance on recommended sample diameters and sample to detector distances.

10.3 Base the selection of the 129.3 keV or 413.7 keV gamma ray for analysis of ^{239}Pu on the plutonium concentration and possible interferences (7, 8).

10.3.1 Analysis of solutions of ^{239}Pu greater than approximately 200 g Pu/l should be based on the 413.7 keV gamma ray. This is due to the increased sample self-attenuation of the 129.3 keV gamma ray and the increased uncertainty associated with its use. Interferences from ^{237}Np as discussed in 6.1.1 may preclude the use of the 413.7 keV gamma ray.

10.3.2 The more intense 129.3 keV gamma ray is preferred for analysis of ^{239}Pu in solutions of less than approximately 200 g Pu/l. However, interferences from high activities of ^{241}Am or ^{237}U , or both, may make the 413.7 keV gamma ray the preferred choice. Possible interferences due to ^{241}Am and ^{237}U and corrective measures are discussed in 6.1.4.

10.4 Select counting time to acquire data necessary to achieve the desired statistical counting precision.

10.5 Position and attenuate the transmission source and count rate correction source to provide count rates with random uncertainty that will not contribute significantly to the overall assay uncertainty.

11. Procedure

11.1 Initial Setup:

11.1.1 Determine the count rate in the peak of the count rate correction source with no other gamma-ray sources present and record along with date of measurement.

11.1.2 Determine the count rate of the transmission source gamma ray peak(s) with no sample container in the instrument and record this rate with date of measurement.

11.1.3 Determine the count rate of the transmission source gamma ray peak(s) through an empty sample container and

record this rate with the date of measurement.

11.1.4 Correct the initial count rates of the transmission and count rate correction source peaks at appropriate intervals for radioactive decay before use in calculation of assay or measurement control results.

11.2 Calibration:

11.2.1 Statistical counting precisions that are at least a factor of three better than the precision observed in routine assays should be obtained in calibration measurements.

11.2.2 Assay each of the standards in random order, recording assay peak count rate, transmission source peak count rate, and count rate correction source peak count rate.

11.2.3 Calculate the calibration function as described in Section 12.

11.2.4 After calibration, all geometric, physical (absorbers, containers, etc.), and electronic parameters must remain fixed. Any alteration will require recalibration.

11.3 Daily Start-Up:

11.3.1 Measure the count rate of the count-rate correction source gamma ray peak with no other gamma-ray sources present.

11.3.2 Measure the count rate of the transmission source gamma ray peak with no sample in the instrument.

11.3.3 Use the daily measured peak count rates of the transmission source and count-rate correction source as part of the measurement control program outlined in 11.4.

11.3.4 Perform background measurement.

11.3.5 Perform other measurement control as described in 11.4.

11.4 Measurement Control:

11.4.1 Establish a measurement control program to monitor system parameters and generate reports of system status. Monitored characteristics should include, but are not limited to, system gain and resolution, count rate correction source and transmission source peak rates (properly corrected for radioactive decay), and background radiation levels.

11.4.2 Confirm the system gain stability on at least a daily basis by verifying the locations of the count rate correction, transmission, and nuclide assay peaks. Large drifts in peak location, which can cause an error in peak area, indicate a problem that must be corrected.

11.4.3 Measure the system resolution on both high and low energy gamma-ray peaks on a daily basis. Set limits for resolution which reflect the ability of the peak area calculation software to adapt to variable peak widths. A significant loss of resolution accompanied by asymmetric peak shape, which is most evident in the higher energy gamma-ray peaks, may be indicative of neutron damage to the detector. An increase in system electronic noise will also cause loss of resolution, which is most noticeable at lower energy gamma-ray peaks.

11.4.4 On a daily basis, determine the transmission and count-rate correction source activities and compare them to values predicted by decay equations. Activity values that differ by more than three standard deviations from the predicted values are an indication of problems to be investigated by a technical expert.

11.4.4.1 Consistent measured activity values of the count-rate correction source with no sample or transmission source

activity present serve as a monitor of constant detector efficiency and electronic stability.

11.4.4.2 Consistent measured transmission source activity values with no sample present serve as a monitor of hardware position stability, detector efficiency, and electronic stability.

11.4.5 On a daily basis at varying times, check for the presence of background peaks in the gamma-ray spectrum that would interfere with the measurement of the peak area of either the assay, transmission, or count rate correction gamma rays. The cause of high or varying interfering background should be investigated and minimized as much as practical.

11.4.6 Assay a standard on a daily basis. Where an interfering background has been identified, two standards with nuclide concentrations at the extremes of the calibration range should be used. These measurements will detect any changes in the system or environment that will invalidate the calibration. Consistent measured values verify the proper operation of both mechanical and electronic hardware as well as good background control.

11.4.6.1 Measurement of a low concentration standard is a more sensitive verification of the calibration curve intercept.

11.4.6.2 Measurement of a high concentration standard is a more sensitive verification of the calibration slope.

11.4.7 Perform a periodic precision check of the system by making repeated measurements of a single standard or sample. Compare the variation of the repeated assay results to the estimated precision of a single assay based on counting statistics. A difference between the precision of repeat assay results and the precision based on counting statistics may be due to electronic or mechanical instabilities.

11.4.8 The data from the daily accuracy check and periodic precision check should be plotted on a control chart or otherwise statistically analyzed.

11.5 Routine Assay:

11.5.1 Assay samples without altering system parameters or geometry from those used in calibration.

11.5.1.1 When using the uplooking geometry, sample preparation procedures must ensure a reproducible sample height in the sample vials.

11.5.2 Record the peak areas of the assay, transmission source, and count-rate correction source gamma rays. If conditions exist as described in 6.1.3, record the peak areas of the transmission source and count rate correction gamma rays in one measurement and the peak areas of the assay and count-rate correction source gamma rays in a second measurement.

11.5.3 Calculate results as described in Section 12.

12. Calculation

12.1 Subtract any interfering background rate from the appropriate count rate of the chosen peak and apply any necessary decay corrections. Correct the assay and transmission source gamma-ray count rates for count-rate related losses using (Eq 1).

$$A' = A(L_o/L) \quad (1)$$

where:

A' = net assay or transmission peak count rate corrected for count-rate-related losses,

A = observed peak area,

L_o = count rate of the count rate correction source measured with no other gamma-ray sources present, and

L = observed area of the count-rate correction source.

12.2 Calculate the transmission of the empty sample container at the assay gamma-ray energy using (Eq 2) for the case of two transmission correction gamma rays bracketing the assay gamma-ray energy and (Eq 3) for the case of a single transmission correction gamma ray.

$$T_c = WA(TA'/TA'_o) + WB(TB'/TB'_o) \quad (2)$$

$$T_c = (TA'/TA'_o)^{KA} \quad (3)$$

where:

T_c = sample container transmission at assay energy,

TA', TB' = transmission source peak count rates measured through empty container corrected for rate-related losses,

TA'_o, TB'_o = transmission source peak count rates measured with no container present corrected for rate-related losses,

KA = ratio of the linear attenuation coefficients at the assay and transmission source energies, and

WA, WB = transmission source weighting factors, based on a linear interpolation of \ln energy versus $\ln(-\ln T)$ to derive the transmission at the assay energy from the transmission at the transmission source energies (Test Method C 1133 and Ref (9)).

12.3 Calculate the transmission of the sample at the assay energy using (Eq 4) for a single transmission source gamma ray and (Eq 5) for the case of two transmission source gamma rays.

$$T = \frac{(TA'_s/TA'_o)^{KA}}{T_c} \quad (4)$$

$$T = \frac{WA(TA'_s/TA'_o) + WB(TB'_s/TB'_o)}{T_c} \quad (5)$$

where:

T = transmission of the sample at the assay energy, and

TA'_s, TB'_s = transmission source peak count rates measured through the sample, corrected for rate-related losses.

12.4 Calculate the total correction factor for sample and container absorptions for a slab geometry using (Eq 6):

$$CF_{\text{slab}} = \frac{-1 \ln(T)}{\sqrt{T_c} (1 - T)} \quad (6)$$

For a cylindrical geometry, use (Eq 7):

$$CF_{\text{cyl}} = \frac{-1 k \ln(T)}{\sqrt{T_c} (1 - T^k)} \quad (7)$$

where:

$k = \pi/4$.

Eq 6 and Eq 7 are far-field approximations of the correction

factors. Adjusting the factor k may improve results for specific geometries and transmissions as explained in Ref. (3).

12.4.1 Alternate methods for calculating the correction factors for this and other geometries may be found in Ref. (3). Eq 6 and Eq 7 assume that both walls of the sample container, or the top and bottom depending on the chosen geometry, have the same transmission for the assay gamma rays.

12.5 Calculate the instrument response for each standard using (Eq 8). Use the appropriately determined correction factor for attenuation.

$$K_i = A' \times CF \quad (8)$$

where:

K_i = instrument response (cts/s) for the i^{th} standard,
 A' = count-rate corrected assay peak rate (cts/s), and
 CF = appropriate correction factor.

12.6 Using the known standard concentrations and the results from calculation of the K_i s as in 12.5, compute a linear calibration function using standard statistical methods. Determine the calibration slope, m , and intercept, b .

12.7 For routine assays, the appropriate total correction factor is applied to the assay gamma ray peak area to compute the total corrected count rate for the assay gamma ray. This result is then used in the calibration function to compute the assay result as shown in (Eq 9).

$$M = m(A' \times CF) + b \quad (9)$$

where:

m = linear calibration slope, determined in 12.6,
 M = concentration of nuclide, and
 b = intercept.

12.8 Reasonable estimates of random error due to counting statistics can be obtained from standard propagation of variance techniques. Details of such calculations may be found in Test Methods C 1133.

13. Precision and Bias

13.1 Precision:

13.1.1 The precision of the assay is a function of counting

statistics, geometric precision of sample containers, electronic stability and, in the uplooking geometry, the sample height. Sources of error and their magnitudes are discussed in detail in Ref. (6).

13.1.2 Precision may be improved by increased counting time. Higher transmission source intensity may improve the precision as long as the higher count rate does not introduce other uncertainties.

13.1.3 The relative precision (one sigma) for ^{239}Pu assays has been reported to be <1 % for concentrations ranging from 0.5 to 500 g Pu/l (10) in assay times of 45 min or less.

13.1.4 The relative precision (one sigma) for ^{235}U assays is approximately 0.1 % in 1000 s counting times for solution concentrations above 200 g U/l. At lower concentrations the relative precision decreases to 0.5 % (6).

13.2 *Bias*—Factors that can introduce a bias in this test method include uncontrolled background, contamination of the sample holder, sample collection, and sample preparation technique. Since each of these factors may vary, their effect on the bias of the analysis must be evaluated on an individual basis depending on actual analysis conditions. The factors and their effects are discussed in detail in Section 6 and in Ref (6). The following bias statements are based on ideal situations:

13.2.1 Under well-controlled laboratory conditions, a bias of 0.1 % has been observed in this test method for ^{235}U assays on solutions ranging from 1 to 500 g U/l (6).

13.2.2 A maximum bias of 0.5 % in the test method has been achieved in ideal situations for assays of plutonium solutions from 1 to 500 g/L (7, 10).

13.2.3 An intercept in the calibration function which is statistically non-zero may indicate the presence of one or more of the aforementioned biases.

14. Keywords

14.1 gamma-ray spectroscopy; nondestructive assay; plutonium; special nuclear material; uranium

REFERENCES

- (1) Reilly, T. D., and Parker, J. L., "A Guide to Gamma-Ray Assay for Nuclear Materials Accountability," LA-5794-M, Los Alamos National Laboratory, 1977.
- (2) Parker, J. L., and Reilly, T. D., "Bulk Sample Self-Attenuation Correction by Transmission Measurements," *Proceedings of ERDA Symposium on X- and Gamma-Ray Sources and Applications*, 1975, pp. 219–222.
- (3) Parker, J. L., "The Use of Calibration Standards and the Correction for Sample Self-Attenuation in Gamma-Ray Nondestructive Assay," LA-10045, Rev., Los Alamos National Laboratory, 1986.
- (4) Knoll, G. F., *Radiation Detection and Measurement*, 2nd ed., John Wiley and Sons, New York, NY, 1989, p. 302.
- (5) Hartwell, J. K., and Goodwin, S. G., "Pulsar Injection with Subsequent Removal—Implementation and Applications," *IEEE Trans. Nucl. Sci.*, Vol 36, No. 1, 1989, p. 801.
- (6) Parker, J. L., et al., "The Development of a State-of-the-Art Assay System for Uranium-235 in Solutions," LA-10793-MS, Los Alamos National Laboratory, 1986.
- (7) Li, T. K., "Automated In-Line Measurement of Plutonium Solutions in a Plutonium Purification Process," *Nuclear Technology*, Vol 55, 1981, pp. 674–682.
- (8) Li, T. K., Marks, T., and Parker, J. L., "Solution Assay Instrument Operations Manual," LA-9820-M, Los Alamos National Laboratory, 1983.
- (9) U.S. Nuclear Regulatory Commission, *Passive Nondestructive Assay of Nuclear Materials*, NUREG/CR-5550, NTIS, 1991, pp. 185–187.
- (10) Parker, J. L., "A Plutonium Solution Assay System Based on High-Resolution Gamma-Ray Spectroscopy," LA-8146-MS, Los Alamos National Laboratory, 1980.

The American Society for Testing and Materials takes no position respecting the validity of any patent rights asserted in connection with any item mentioned in this standard. Users of this standard are expressly advised that determination of the validity of any such patent rights, and the risk of infringement of such rights, are entirely their own responsibility.

This standard is subject to revision at any time by the responsible technical committee and must be reviewed every five years and if not revised, either reapproved or withdrawn. Your comments are invited either for revision of this standard or for additional standards and should be addressed to ASTM Headquarters. Your comments will receive careful consideration at a meeting of the responsible technical committee, which you may attend. If you feel that your comments have not received a fair hearing you should make your views known to the ASTM Committee on Standards, 100 Barr Harbor Drive, West Conshohocken, PA 19428.